



REX-AD410



General Description

The REX-AD410 Digital Indicator is a high performance indicator with a large, bright LED display measuring 20mm. This full feature indicator has universal inputs that include thermocouples, RTD's, voltage, and current inputs. Other optional features include up to 6 programmable alarms with relay outputs, analog retransmission, contact inputs, and digital communications.

When used with the input selector SP-400/SP-4, the REX-AD410 can display up to 16 inputs. The REX-AD410B option allows for the controller to act as a high or low limit device. The REX-AD410 matches the physical appearance of the D series of controllers (REX-D100/D400/D900).

Features

- ☆ Universal inputs
- ☆ Bright, easy-to-read LED Display
- ☆ Limit control functions (REX-AD410B)
- ☆ Peak and bottom hold function
- ☆ Up to 6 alarms
- ☆ Digital communications

Universal Inputs

Input type can be configured among 12 types of thermocouples, two types of RTDs and eight types of voltage/current inputs.

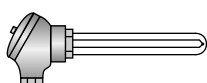

K, J, R, S, B, E, N, T, U, L
W5Re/W26Re, PLII

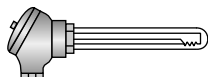

Pt100, JPt100

0 to 10mV DC, 0 to 100mV DC, 0 to 1V DC, 0 to 5V DC
1 to 5V DC, 0 to 10V DC, 0 to 20mA DC, 4 to 20mA DC

Bright, Easy-To-Read LED Display

The REX-AD410 has a very clear and easy-to-read large LED display (20mm high).

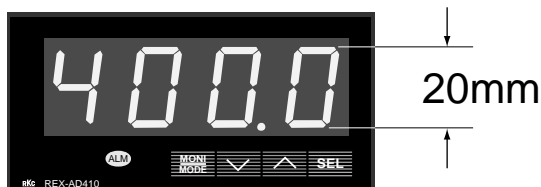

Limit Controller

The REX-AD410B is a limit controller with up to 4 alarm outputs. When the temperature goes above the set value (high limit) or below the set value (low limit), the REX-AD410B will interrupt or remove the power from the process.

Example : For a high alarm.

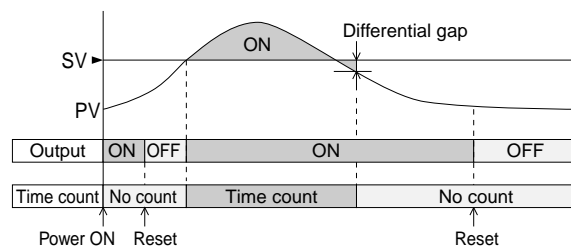

Peak and Bottom Hold

The REX-AD410 memorizes the maximum and minimum measured value. Optional contact input function enables you to remotely reset the values.

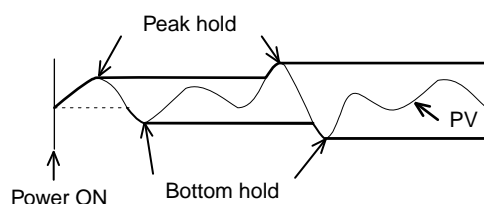

Specifications

Input

Input (Universal input)

- a) Thermocouple : K, J, R, S, B, E, T, N (JIS/IEC), PLII (NBS) W5Re/W26Re (ASTM), U, L (DIN)
- Influence of external resistance : Approx.0.4 μ V/ Ω
 - Input break action : Up-scale
- b) RTD : Pt100 (JIS/IEC), JPt100 (JIS)
- Influence of lead resistance : Approx. less than 10 Ω
 - Input break action : Up-scale
- c) DC low voltage input : 0 to 10mV, 0 to 100mV, 0 to 1V
- Input break action : Up-scale
- d) DC high voltage input : 0 to 5V, 1 to 5V, 0 to 10V
- Input break action : Down-scale
- e) DC current input : 0 to 20mA, 4 to 20mA
- For DC current input, connect a 250 Ω resistor to the input terminals.
 - Input break action : Down-scale

Sampling Time

0.5 sec

PV Bias

- Temperature input : -1999(-199.9) to 9999 (999.9) $^{\circ}$ C [$^{\circ}$ F]
 DC voltage, DC current : -1999 to 9999
 (A decimal point is same as PV)

Performance

Measuring Accuracy

- \pm (0.3% of span + 1 digit)
 Cold junction temperature error
 Within $\pm 1.5^{\circ}$ C (between 0 and 50 $^{\circ}$ C [32 and 122 $^{\circ}$ F])
 •Accuracy is not guaranteed between 0 and 400 $^{\circ}$ C (0 and 752 $^{\circ}$ F) for type B input.
 •Accuracy is not guaranteed between 0 and 32 $^{\circ}$ F for type N, PLII and W5Re/W26Re input.

Insulation Resistance

- More than 20M Ω (500V DC) between measured terminals and ground
 More than 20M Ω (500V DC) between power terminals and ground

Dielectric Strength

- 1000V AC for one minute between measured terminals and ground
 1500V AC for one minute between power terminals and ground

Hold

- Peak Hold** : Highest measured value is held
Bottom Hold : Lowest measured value is held

- The held values can be reset manually or by external contact signal after the confirmation by the operator.
- Data is not backed up when the instrument power supply is off.
- In case of a limit controller, the highest or lowest measured value above or below the limit is displayed.

Alarms

(Optional)

Alarm

- a) Number of alarms : Up to 6 points
 (Up to 4 points in case of limit controller)
 b) Alarm action : Process (high, low), Deviation (high, low, band and range)
- Deviation alarm is available only for the limit controller.
- c) Alarm delay timer : 0 to 600 sec
 d) Alarm differential gap : 0.0 to 10.0 $^{\circ}$ C ($^{\circ}$ F), 0 to 10 $^{\circ}$ C ($^{\circ}$ F) or 0.0 to 10.0% of span
- Energized/de-energized alarm (selectable)

Alarm Output

Relay contact output, 250V AC 0.5A (resistive load), Form A contact

Options

External contact input

- a) Number of input : 2 points (DI1 and DI2)
 b) Type : DI1 : (1) Hold reset, (2) Output reset, (3) Time count reset
 •(2) and (3) are available only for the limit controller.
 DI2 : Alarm interlock reset

Analog Output

- a) Number of output : 1 point
 b) Output signal : 0 to 10mV, 0 to 100mV, 0 to 5V, 0 to 10V, 1 to 5V DC
 (Allowable load resistance : More than 1k Ω)
 0 to 20mA, 4 to 20mA DC
 (Allowable load resistance : Less than 600 Ω)
 c) Output type : PV (Programmable)
 •Analog output is not available when LED drive power supply for SP-4/SP-400 is specified.

LED Drive Power Supply for SP-4/SP-400

- Output : 12V DC $\pm 10\%$, and 20mA DC
 •Number of SP-4 units that can be multi-dropped : Up to 2 with the transfer type and 1 without the transfer type.
 •This option is not available when the limit controller or the analog output is specified.

Communications

- a) Communication method : RS-485 (2-wire), RS-422A (4-wire)
 b) Communication speed : 1200, 2400, 4800, 9600, 19200 BPS
 c) Bit format
 Start bit : 1
 Data bit : 7 or 8
 Parity bit : Even, odd or without parity
 Stop bit : 1 or 2
 d) Communication code : ASCII(JIS) 7-bit code
 e) Maximum connection : 31 (Address can be set from 0 to 99.)

Limit Control Functions (REX-AD410B)

- a) Integrated time measuring :
 0 hr 0 min to 99 hr. 59 min/ 0 min 0 sec to 99 min to 59 sec
 •If the integrated time exceeds 99 hours 59 minutes (99 minutes 59 seconds), the display of " - - - " will blink.
- b) Action : Counts up the time during the measured value goes below the set value (when high limit control), or goes below the set value (when low limit control).
- The integrated time can be reset by either key operation or the digital input.
 - Data is not backed up when the instrument power supply is off.
- c) Number of output : 1 point
 d) Output action : High or low limit (Factory set value : High limit)
 e) Setting range : The same as input range
 f) Differential gap : 0.0 to 10.0 $^{\circ}$ C ($^{\circ}$ F) , 0 to 10 $^{\circ}$ C ($^{\circ}$ F) or 0.0 to 10.0% of span
 g) Output : Relay contact output, 250V AC 0.5A (resistive load), Form A contact

General Specifications

Supply Voltage

- a) 90 to 264V AC (Including supply voltage variation)
 [Rating : 100 to 240V AC] (50/60Hz common)
 b) 21.6 to 26.4V AC (Including supply voltage variation)
 [Rating : 24V AC] (50/60Hz common)
 c) 21.6 to 26.4V DC (Ripple rate 10% p-p or less)
 [Rating : 24V DC]

Power Consumption

- Less than 10.5VA (100 to 240V AC)
 Less than 7.0VA (24V AC)
 Less than 200mA (24V DC)

Power Failure Effect

A power failure of 20msec or less will not affect the control action.

Operating Environments : 0 to 50 $^{\circ}$ C [32 to 122 $^{\circ}$ F] , 45 to 85% RH

Memory Backup : Backed up by EEPROM.

Data Retaining Period : Approx 10 years (depends on storage and operating conditions.)

Net Weight : Approx. 300g

External Dimensions (W x H x D) 96 x 48 x 100mm

Model and Suffix Code

Specifications	Model and Suffix Code					
Model	AD410	□ - □ * □ - □ - □ - □ / CE				
Type	Indicator Limit controller	A				
Supply voltage	24V DC / AC 100 to 240V AC	B	3 4			
Contact output ¹	Not supplied Specify 1 to 6 (4: Limit controller)			N <input type="checkbox"/>		
Contact input	Not supplied Two contact inputs				N 2	
Analog output / LED power supply	Not supplied Power supply for SP-400/500 LED (Only AD410A) See Analog Output Code Table				N P <input type="checkbox"/>	
Digital communications ²	Not supplied RS-422A (4-wire system) RS-485 (2-wire system)					N 4 5
Safety standard	CE Mark, UL Recognized and USA Certified					/ CE

¹ When a limit controller is specified, up to 4 outputs can be specified.

² When DI's are specified, RS-422A is not available.

Range and Input Table

Thermocouple

Input	Range	Input	Range
K	-199.9 – 999.9°C	B ¹	0 – 1820°C
	-200 – 1372°C		0 – 3308°F
	-199.9 – 999.9°F	E	-200 – 1000°C
	-330 – 2500°F		-330 – 1832°F
J	-199.9 – 999.9°C	N ²	0 – 1300°C
	-200 – 1200°C		0 – 2372°F
	-199.9 – 999.9°F	PLII ²	0 – 1390°C
	-330 – 2192°F		0 – 2534°F
T	-199.9 – 400.0°C	W5Re ²	0 – 2300°C
	-199.9 – 752.0°F	W26Re	0 – 4208°F
R	0 – 1769°C	U	0 – 600°C
	0 – 3216°F		0 – 1100°F
S	0 – 1769°C	L	0 – 900°C
	0 – 3216°F		0 – 1600°F

RTD

Input	Range
JPt100	-199.9 – 510.0°C
	-199.9 – 950.0°F
Pt100	-199.9 – 660.0°C
	-199.9 – 999.9°F

Voltage/Current

Input	Range
0 - 10mV	Scale range and decimal point are programmable in the range of -1999 to 9999.
0 - 100mV	
0 - 1V	
0 - 5V	
1 - 5V	
0 - 10V	
0 - 20mA	
4 - 20mA	

Note : For DC current input, connect a 250Ω resistor to the input terminals.

¹ Accuracy is not guaranteed between 0 and 400°C (0 and 752°F) for type B.

² Accuracy is not guaranteed between 0 and 32°F for type N, PLII and W5Re/W26/Re.

Analog Output Code Table

1	0 - 10mV DC	2	0 - 100mV DC	3	0 - 1V DC	4	0 - 5V DC	5	0 - 10V DC
6	1 - 5V DC	7	0 - 20mA DC	8	4 - 20mA DC				

Panel Mounting Type Indicator REX-AD410

External Dimensions and Rear Terminals

Unit : mm

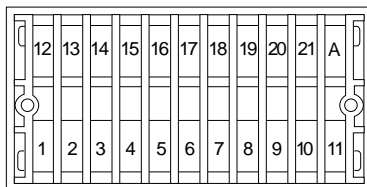
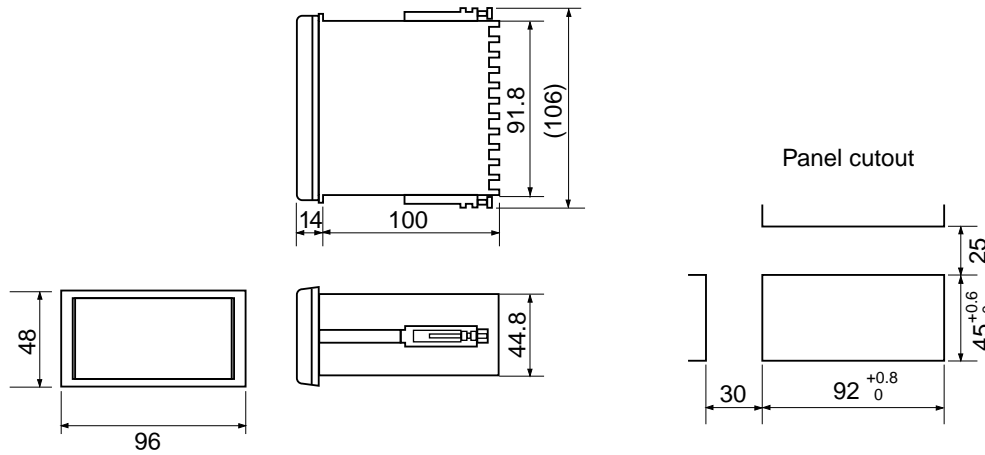

12	13	14	15	16	17	18	19	20	21	A
RS-422A						Analog output		Alarm output		
SG	T(A)	T(B)	R(A)	R(B)		AO				
RS-485			Contact input			Power supply for LED		Relay contact output		
SG	T/R(A)	T/R(B)	DI1	DI2		LED				
Communications					COM(-) HOLD RESET INTERLOCK RESET				Alarm output (Limit controller)	
									Relay contact output	

1	2	3	4	5	6	7	8	9	10	11
AC		Alarm output			Alarm output			TC		
AC		Relay contact output			Relay contact output			RTD		
DC		Relay contact output			Relay contact output			DC		
Power supply								Measured input		