

THV-A1



General Description

As the THV-A1 single phase power control unit can be used with control modes selectable from constant voltage, constant current and constant power, it can be used with such heaters as noble metals (Platinum and molybdenum), super Kanthal, and SiC (Silicon Carbide) that have changing resistance in accordance with temperature changes.

Optional features like heater break alarm and communication can improve system safety and establishment of a supervisory system.

Features

- ☆ Control type selection
(Phase-angle/continuous zero-cross/zero-cross)
- ☆ Communication function
- ☆ Detects heater break of non-linear load
- ☆ Ramp-up, Ramp-down
- ☆ Gradient setting
- ☆ Output Limiter High and Low
- ☆ Base-up Setting (output bias)
- ☆ Output mode selection
(proportional electric power/voltage/phase angle)
- ☆ Digital input for Auto/manual

Communication

With the communication function, a connection to a host computer and an MMI is possible.
(Protocol: Modbus-RTU)

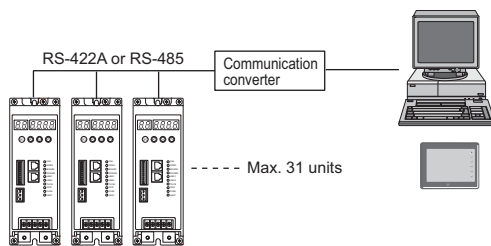

Constant current control (For phase control only)

This function maintains the output current constant when a load or a power supply fluctuates. It makes the THV Series suitable for heaters of which resistance greatly changes by temperature change, such as Platinum, Molybdenum, Tungsten, and Kanthal heaters.

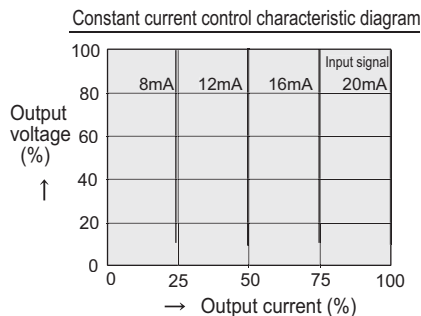

Constant power control (For phase control only)

This function controls the output to make its effective value power proportional to the input. It makes the THV Series suitable for heaters of which resistance gradually increases by temperature or time, such as silicon carbide type heater.

This function controls its effective value power at 50% of the rating shown in the diagram below.

- From the diagram below, constant power control is expressed as a curve obtained from a line between two points which is a 50% of the rating of the unit; a point at 100% voltage x 50% current and a point at 50% voltage x 100% current.

Constant power control characteristic diagram

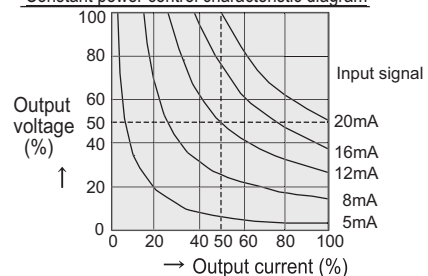

Load current limiter (For phase control only)

This function limits the load current value to the heater. The setting range is 30 to 100% of the rated current.

- (Note) If the load has a large inrush current, use soft-start function along with this function to suppress the inrush current.
This function alone can not prevent the inrush current.

Current limiter characteristic diagram

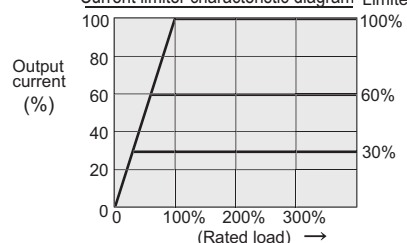

Features

Output modes

When phase control is selected for linear load (R: resistor), output mode can be selected among Proportional phase angle to input, proportional voltage to input, proportional square voltage (electric power) to input, proportional square voltage feedback to input and constant voltage control.

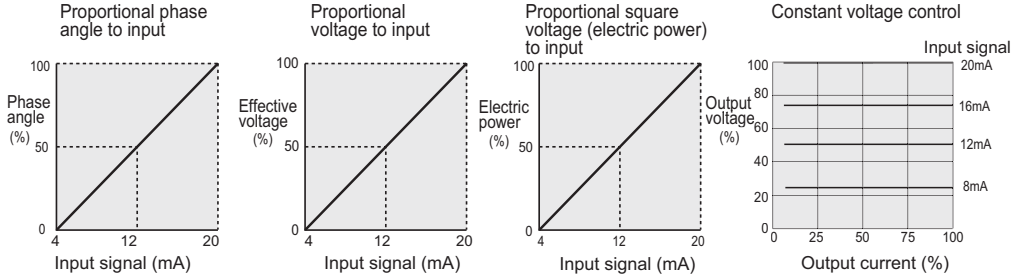

Three Types of Control Mode (Selectable)

● Phase control

The wave form of the load power is switched at a desired phase angle ϕ to provide smooth control.

● Zero-cross control (Continuous proportion)

Power is switched on and off when the supply voltage is at 0V. This system suppresses high frequency noise inherent to phase control.

● Zero-cross control (Input synchronization system)

Supply voltage is switched on and off according to the voltage pulse and contact signals from a controller.

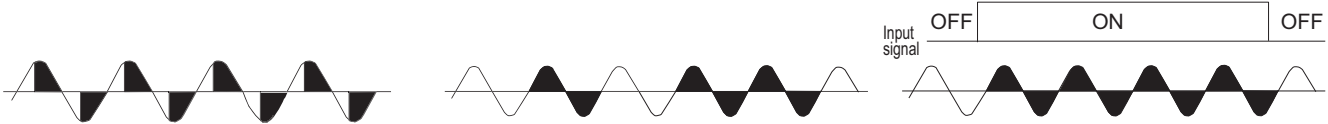

Detects heater break of non-linear load

Patent pending

Heater break alarm can be used at up to three inflection points in accordance with heater characteristics. The unit can be used with a load with large resistance changes by temperature (e.g. lamp heaters). There is no need of calculation for inflection points as automatic setting is possible.

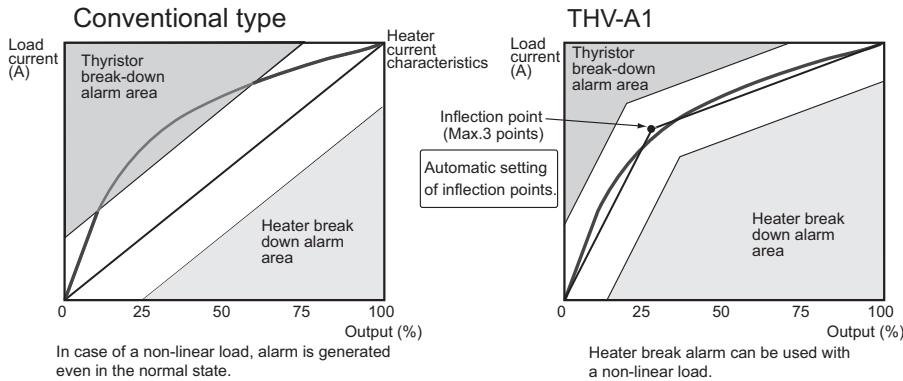

Memory area

The THV-A1 stores 4 patterns of heater break alarm settings and enables easy change of settings.

- Memory area is not available with heater break alarms for non-linear load.

Area 4	
Maximum load current for alarm	
Heater break alarm set-value	
Heater break alarm 2 set-value	
Thyristor break-down alarm set-value	
Current limiter set-value	

Area 2	

Area 1	
Maximum load current for alarm	
Heater break alarm set-value	
Heater break alarm 2 set-value	
Thyristor break-down alarm set-value	
Current limiter set-value	

Gradient Setting

The relation between the setting input and the output voltage can be set. Gradient setting is possible via front keys or an external setter. Control characteristics may vary with the setting as follows.

1. Auto setting input X Internal gradient setting X External gradient setting
2. Auto setting input X Internal gradient setting
3. Manual setting X Internal gradient setting X External gradient setting

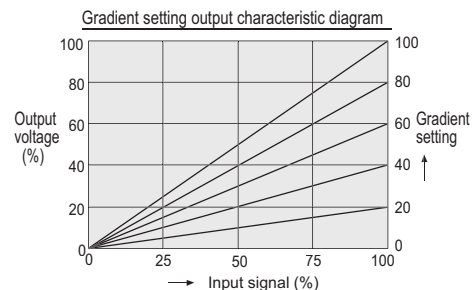

Features

Ramp Function (Soft-start & Soft-down)

Even if setting input changes abruptly, output changes slowly to suppress inrush current. Ramp-up (Start-up) and ramp down (Start-Down) time can be set in the range of 0.1 to 99.9 sec via front keys.

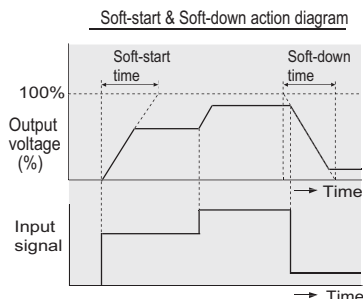

Base-up setting (Output bias)

When the setting input is zero, the output can be set via front keys.

(Base-up setting is valid when output limiter low is set to 0.0)

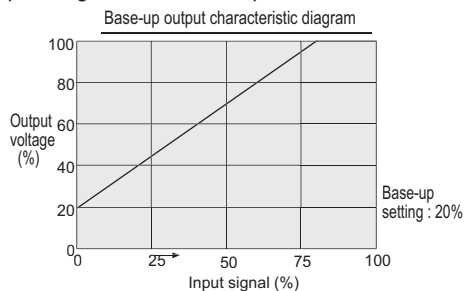

Event input

Functions can be assigned to three external contact inputs. Switching of functions can be made externally with contact signals.

RUN/STOP
Auto/Manual
Alarm interlock reset
Heater break alarm : Use/Unuse
Soft-up/Soft/down : Use/Unuse
Key lock : Use/Unuse
Over current alarm : Use/Unuse
Multi-memory area selection (DI: 2 points)

• Heater break alarm, over current alarm and multi-memory area selection are optional.

Heater break alarm

This function measures load current and compares it with a heater break alarm set value. Alarm will be activated if the load current goes into alarm ranges. Maximum two alarm set points can be set for the heater break alarm, which could be used for heater-deterioration alarm and heater-break alarm.

(Note) For phase control, heater break alarm does not work when the load current is less than 15% of maximum load current.

Output limiter (High & Low)

Highest and lowest output values can be set via front keys.

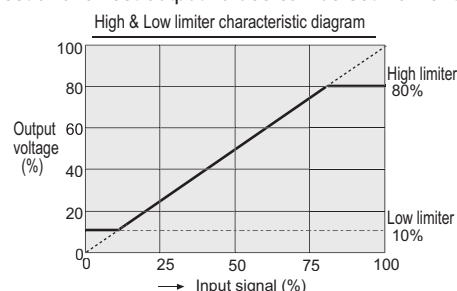

Output limiter High at start-up

This function limits the highest output for the period of a preset time after power-ON and control mode change from Stop to Run. It makes the THV-A1 Series suitable for heaters which cause rush current flow, such as Halogen lamp, Tungsten, Platinum, and Molybdenum heaters.

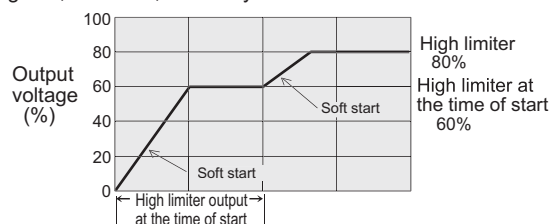

Over-current alarm

The alarm goes on when the load current exceeds 120% of the rated current.

Alarm output

The alarm types are Power supply voltage abnormal, Power frequency abnormal, Board alarm, Over current alarm, Fuse break alarm, Thyristor break alarm, and Heater break alarm. Alarm output will go on, when any of them goes in alarm status.

(Alarm logic selection, Alarm output : 2 points)

Specifications

Maximum Load Current

20A AC, 30A AC, 45A AC, 60A AC, 80A AC, 100A AC, 150A AC, 200A AC

Control Method

Phase control, Zero-cross control (Selectable)

Applicable Load

Phase control : Linearity (R:Resistor) load, Control of primary side of a transformer (magnetic field density 8,000 gauss or less)

Zero-cross control : Linearity (R:Resistor) load

Input Signal

Group 1 (Field-programmable within Group)

Current input 4 to 20mA DC (Input impedance : 100Ω)
 Current input 0 to 20mA DC (Input impedance : 100Ω)
 Voltage input 0 to 5V DC (Input impedance : 30kΩ)
 Voltage input 1 to 5V DC (Input impedance : 30kΩ)
 Voltage pulse input 0/12V DC (Input impedance : 30kΩ)
 Non-voltage contact input

Group 2 (Field-programmable within Group)

Voltage input 0 to 10V DC (Input impedance : 60kΩ)
 Voltage pulse input 0/12V DC (Input impedance : 60kΩ)
 Voltage pulse input 0/24V DC (Input impedance : 60kΩ)
 Non-voltage contact input

a) Current input 4 to 20mA DC (Input impedance : 100 Ω)
 b) Voltage input 1 to 5V DC (Input impedance : 30kΩ)
 c) Voltage input 0 to 10V (Input impedance : 68kΩ)
 d) Voltage pulse input 0/12V DC (Input impedance : 30kΩ)
 e) Non-voltage contact input (Input impedance : 47Ω)

Output mode

a) Constant voltage control
 b) Proportional phase angle • Proportional voltage • Proportional square voltage • Proportional square voltage feed back [when phase control is selected for linearity load (R: resistor)]
 c) Constant current control
 d) Constant power control
 • a), b) : Standard function, c), d) : Optional function

Input sampling cycle

0.5 cycle of power cycle

Minimum Load Current

0.5A (at 98% output of rated voltage)

Output Voltage Range

0 to 98% of rated voltage

Power OFF leakage current

20A, 30A, 45A, 80A 100A AC type
 27mA AC rms or less (load voltage 200V rms, 60Hz, Ta=25°C)
 150A, 200A AC type
 90mA AC rms or less (load voltage 200V rms, 60Hz, Ta=25°C)

Power Supply Voltage

90 to 264V AC (Including power supply voltage variation)
 [Rating : 100 to 240V DC]

Power Frequency

50/60Hz (Automatic discriminating)

Allowable Power Frequency Variation

50Hz±1Hz, 60Hz±1Hz, (Performance guarantee range)
 45 to 54.9Hz (50Hz), 55 to 64.9Hz (60Hz) (Operating guarantee range)

Allowable Ambient Temperature

Performance guarantee range: 0 to +50°C (60A type : 0 to +45°C)
 Operating guarantee range: -15 to +55°C (20A,30A,45A,60A,80A,100A type)
 -10 to +55°C (150A,200A type)

Operating ambient humidity

5 to 95%RH (Non-condensing)
 Absolute humidity : MAX.W.C 29.3g/m³ dry air at 101.3kPa

Cooling method

20A, 30A, 45A, 80A 100A AC type : Natural convection
 150A, 200A AC type : Air cooling (Built-in cooling fan)

Dielectric voltage

Between main circuit terminals, power terminals and heat sink 2000V AC for one minute.
 Between main circuit terminals, power terminals and input terminals 2000V AC for one minute.

Insulation resistance

Between main circuit terminals, power terminals and heat sink 20MΩ or more (500V DC)
 Between main circuit terminals, power terminals and input terminals 20MΩ or more (500V DC)

Mounting Method

Vertical mounting

Weight

Approx. 1.4kg (20A, 30A), Approx. 1.6kg (45A, 60A)
 Approx. 2.4kg (80A, 100A), Approx. 4.5kg (150A, 200A),

Power consumption

20A, 30A, 45A, 80A 100A AC type
 Less than 6VA (at 100V AC), Rush current 10A or less
 Less than 8VA (at 240V AC), Rush current 24A or less
 150A, 200A AC type
 Less than 14VA (at 100V AC), Rush current 22A or less
 Less than 22VA (at 240V AC), Rush current 52A or less

Self-diagnostic function

Check item

a) Data check, Back-up check, Power frequency check, Main circuit power supply check, A/D converter check
 b) Power supply voltage check, Watch dog-timer

Action at abnormality :

Check item a) : Control stop, Board abnormality lamp ON, Thyristor output OFF

Check item b) : Action stop, FAIL lamp ON, Thyristor output OFF

Output Setting Range

Gradient setting : 0.0 to 200.0% [Front key],
 0 to 100% [External setting unit]
 Output limiter (High) : 0.0 to 100.0% [Front key]
 Output limiter (Low) : 0.0 to 100.0% [Front key]
 Output limiter at start-up (High) : 0.0 to 100.0% [Front key]
 Output limiter time at start-up (Low) : 0.0 to 600.0 sec [Front key]
 Base-up setting (Output bias) : -10.0 to 100.0% [Front key]
 Manual setting : 0.0 to 100% [Front key]
 0 to 100% [External setting unit]

Standard functions

- Auto/Manual selection (External manual setting unit is optional)
- Gradient setting (External setting unit is optional)
- Soft-up/Soft-down : 0.0 to 100.0sec
- Digital input (DI) : 3 points, Non-voltage contact input
 RUN/STOP, Auto/Manual, Alarm interlock reset
 Heater break alarm : Use/Unuse,
 Soft-up/Soft/down : Use/Unuse
 Key lock : Use/Unuse,
 Over current alarm : Use/Unuse
 Multi-memory area selection (For heater break alarm) (Selectable)
- ON/OFF control (External setting units are optional)

Option function

- Alarm output : 2 points
 Open collector output, 250V AC, 1A (Resistive load)
 Energized/De-energized is selectable.
 (Heater break alarm, Thyristor break alarm, Fuse break alarm, Power supply voltage abnormal, Power frequency abnormal, Over current alarm, Board alarm)
 * Selectable
- Heater break alarm
 Current measuring accuracy : ±2% of rated load current
 Number of alarm delay times : 0 to 99 times
 Memory area : 4 areas
- Load current limiter
 Setting range :
 0.0 to 22.0A (20A type), 0.0 to 33.0A (30A type)
 0.0 to 50.0A (45A type), 0.0 to 66.0A (60A type)
 0.0 to 88.0A (80A type), 0.0 to 110.0A (100A type)
 0.0 to 165.0A (150A type), 0.0 to 220.0A (200A type)
- Heat sink temperature abnormality
 * 150A, 200A type: Standard function
- Communication function
 Communication method : RS-485 (2-wire, half-duplex)
 RS-422A (4-wire, half-duplex)
 Synchronous method : Start-stop synchronous type
 Communication speed : 9600 bps
 Protocol : Modbus-RTU
 Data format : Start bit : 1, Data bit : 8, Parity bit : None
 Stop bit : 1
 Maximum connection : 31 units

Compliance with Standards (20A, 30A, 45A, 60A, 80A, 100A AC Type)

UL : UL61010-1, cUL : CAN/CSA-C22.2 No.61010-1
 CE marking : LVD : EN61010-1

OVERVOLTAGE CATEGORYII,

POLLUTION DEGREE 2,

EMC : EN60947-4-3

* A specified noise filter must be used

SOSHIN ELECTRIC CO., LTD

HF2030A-UP (20A,30A), HF2050A-UP (45A)

HF2060A-UP (60A), HF2080A-UP (80A)

HF2100A-UP (100A)



Table of Stability

Function	Operating condition	Stability
Constant voltage variation	Power supply variation : Within ±10% Load variation : 2 times	Within ±2% of input voltage
Constant current variation	Power supply variation : Within ±10% Load variation : 2 times	Within ±2% of rated current
Constant power variation	Power supply variation: Within ±10% Load variation : 2 times	Within ±4% of rated power

Table of internal calorific value

Rated load current (A)	20	30	45	60	80	100	150	200
Internal calorific value (W)	23	34	56	72	95	116	190	245



Model and Suffix Code

● Rated load current : 20A,30A,45A,60A,80A,100A AC

Specifications	Model and Suffix Code										
Type	THV-A										
Power supply	Single phase 100 to 240V AC	1									
Control method	Phase control/Zero-cross control (programmable, default: phase control)	PZ									
Rated load current	20A AC		0	2	0						
	30A AC		0	3	0						
	45A AC		0	4	5						
	60A AC		0	6	0						
	80A AC		0	8	0						
	100A AC		0	1	0						
Input signal *1	0 to 5V DC					4					
	0 to 10V DC					5					
	1 to 5V DC					6					
	0 to 20mA DC					7					
	4 to 20mA DC					8					
Output mode *2	Standard + Constant voltage control Standard + Constant voltage control + Constant current control (with heater break alarm, thyristor break down alarm, memory area load current limiter and over current alarm)						6				
	Standard + Constant voltage control + Constant power control (with heater break alarm, thyristor break down alarm, memory area load current limiter and over current alarm)						W				
Fast-blow fuse	No fast-blow fuse With fast-blow fuse							N			
Alarm output	No alarm output Alarm output 2 points								N		
Heat sink temperature detection function/ Non-linear resistance heater break alarm (ARC-HBA)	No function									N	
	Heat sink temperature detection function Non-linear resistance heater break alarm • When the output mode is specified to E or W code, this alarm can be selected.									A	
	Heat sink temperature detection function + Non-linear resistance heater break alarm • When the output mode is specified to E or W code, this alarm can be selected.									C	
Communication	No communication RS-422A RS-485									N	
Accessories *3,*4	Setter (Volume, knob, Scale plate) 1 unit + Connector for input (Plug)									4	
	Setter (Volume, knob, Scale plate) 2 units + Connector for input(Plug)									5	
	Connector for input (Plug)										-1
	Connector for alarm output (Plug)										-2

● Rated load current : 20A,30A,45A,60A,80A,100A AC

Specifications	Model and Suffix Code										
Type	THV-A										
Power supply	Single phase 100 to 240V AC	1									
Control method	Phase control/Zero-cross control (programmable, default: phase control)	PZ									
Rated load current	150A AC		1	5	0						
	200A AC		2	0	0						
Input signal *1	0 to 5V DC					4					
	0 to 10V DC					5					
	1 to 5V DC					6					
	0 to 20mA DC					7					
	4 to 20mA DC					8					
Output mode *2	Standard + Constant voltage control Standard + Constant voltage control + Constant current control (with heater break alarm, thyristor break down alarm, memory area load current limiter and over current alarm)						6				
	Standard + Constant voltage control + Constant power control (with heater break alarm, thyristor break down alarm, memory area load current limiter and over current alarm)						W				
Fast-blow fuse	No fast-blow fuse With fast-blow fuse							N			
Alarm output	No alarm output Alarm output 2 points								N		
Heat sink temperature detection function/ Non-linear resistance heater break alarm (ARC-HBA)	Heat sink temperature detection function									A	
	Heat sink temperature detection function + Non-linear resistance heater break alarm • When the output mode is specified to E or W code, this alarm can be selected.									C	
Communication	No communication RS-422A RS-485									N	
Accessories *3,*4	Setter (Volume, knob, Scale plate) 1 unit + Connector for input (Plug)									4	
	Setter (Volume, knob, Scale plate) 2 units + Connector for input(Plug)									5	
	Connector for input (Plug)										-1
	Connector for alarm output (Plug)										-2

*1 : Input signal is programmable within group. When contact input is required, specify the connector for input as an accessory (Either of -1, -2, or -9).

Group 1 | 0 to 20mA DC | 4 to 20mA DC | 0 to 5V DC | 1 to 5V DC | Voltage pulse 0/12V DC | Non-voltage contact

Group 2 | 0 to 10V DC | Voltage pulse 0/12V DC | Voltage pulse 0/24V DC | Non-voltage contact

*2 : Standard output mode : Proportional phase angle • Proportional voltage • Proportional square voltage.

*3 : Setters are for external gradient setting, external manual setting, and external high/low setting for on/off control. Use two units of setter in the following cases;

- When external gradient setting and external manual setting are required.
- High/low setting for on/off control is used.

*4 : It is possible to specify more than one accessories by adding suffix code at the end.

Example: -1-B : Setter (Volume, knob, Scale plate) 1 unit + Connector for input (Plug) + Connector for alarm output (Plug)

-1-2-9 and -4-5 cannot be specified simultaneously.

Power Controller THV-A1 Series

External Dimensions

Unit : mm

○ 20A, 30A, 45A, 60A type

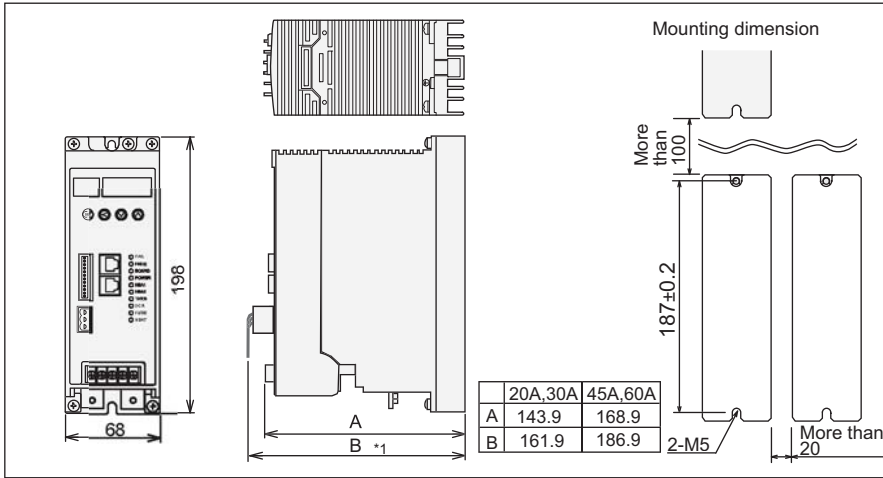

• Install the instrument as illustrated in the drawing to increase the cooling effect.

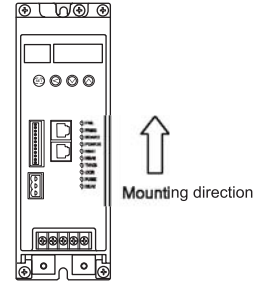

○ 80A, 100A type

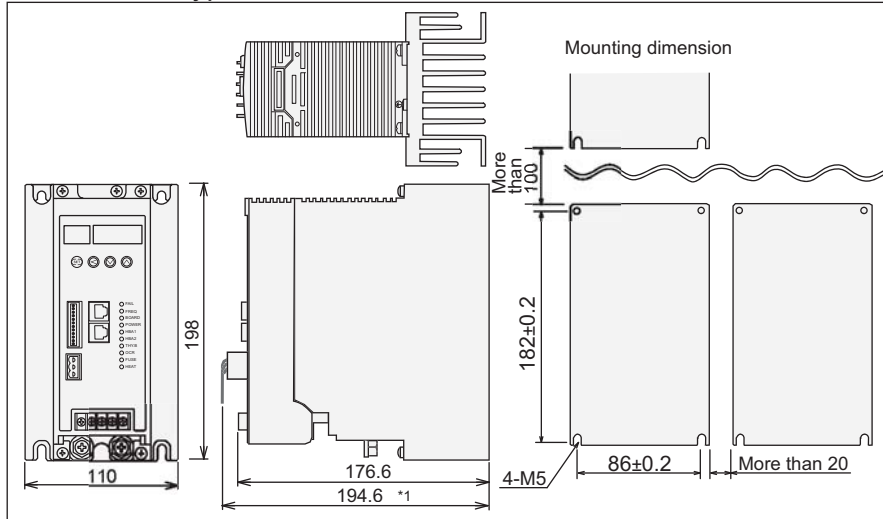

• Temperature characteristics of load current

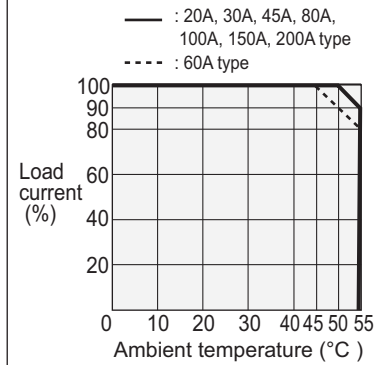

○ 150A, 200A type

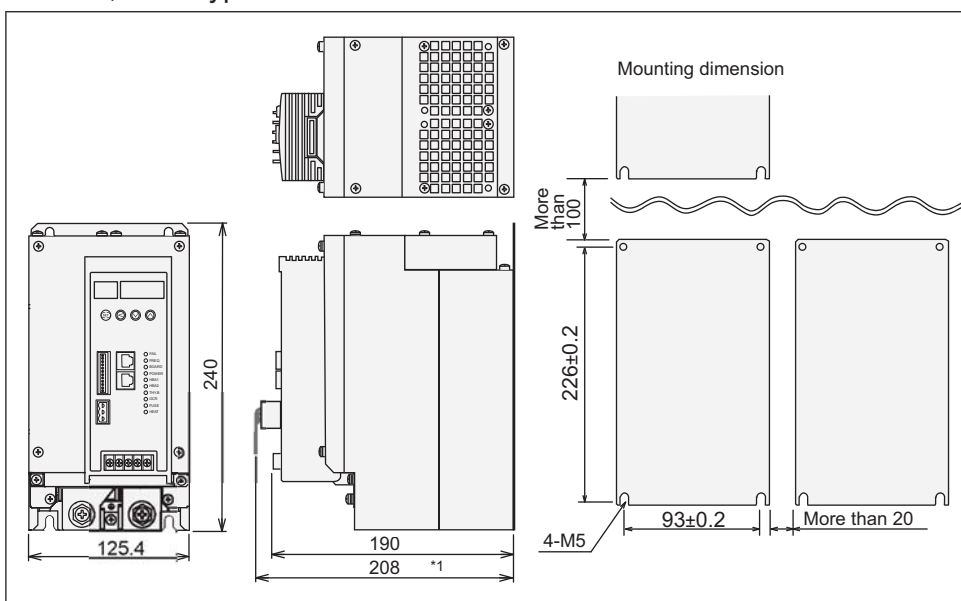

• The front of the instrument can be opened to allow replacement of the fast-blow fuse. When installing the instrument, leave enough space to allow the cover to be opened.

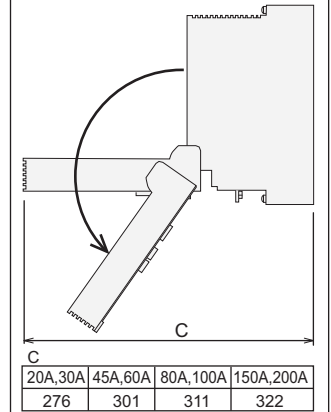

*1 : Length includes that of an optional connector, but space for wiring to connector is not included.

External Wiring

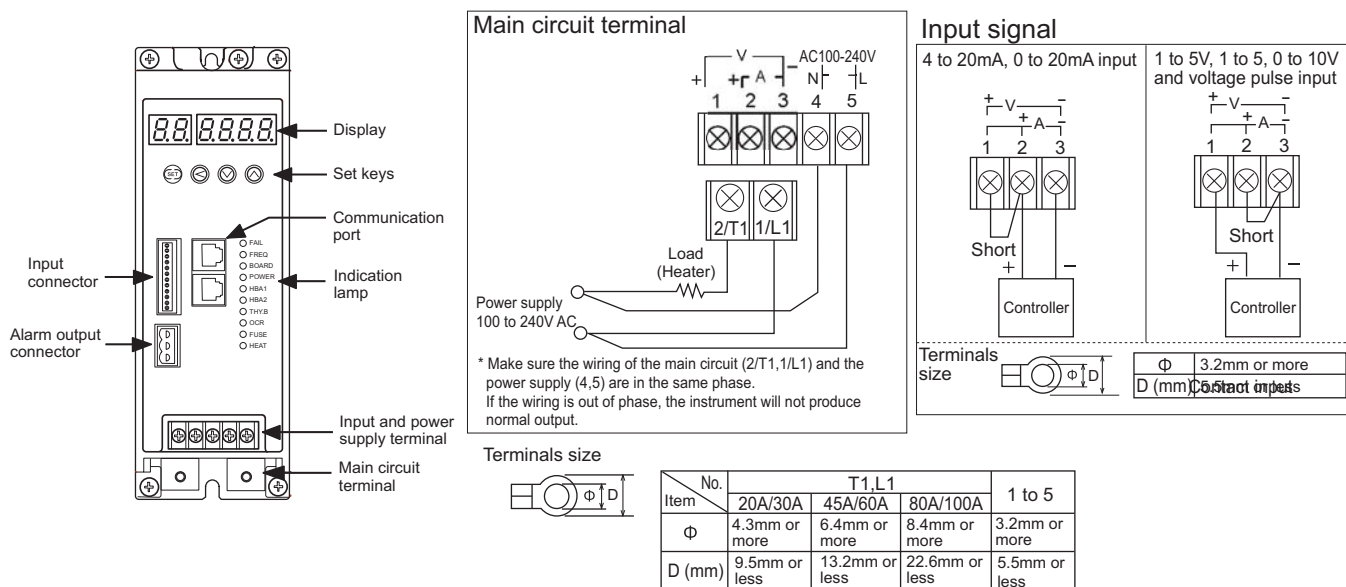

Indication Lamp

INDICATION LAMP	Lamp	Contents
● FAIL	FAIL	FAIL(Self-diagnostic abnormality)
● FREQ	FREQ	Power frequency abnormality
● BOARD	BOARD	Board abnormality
● POWER	POWER	Power supply voltage abnormality
● HBA1	HBA1	Heater break alarm SV1
● HBA2	HBA2	Heater break alarm SV2
● THY.B	THY. B	Thyristor break alarm
● OCR	OCR	Over current alarm
● FUSE	FUSE	Fuse break alarm
● HEAT	HEAT	Heat sink temperature abnormality

* Up to two alarm set points can be set for the heater break alarm.
* Fuse break alarm lamp is available when a fast blow fuse with fuse break alarm output is used.

Connector

* Connector (Plug side) is optional.

Pin No.	Contents
1	+5V (Gradient setting input)
2	0V (Gradient setting input)
3	Gradient setting input (0 to 5V input by gradient setter)
4	+5V (Manual setting input)
5	0V (Manual setting input)
6	Manual setting input (0 to 5V input by manual setter)
7	External contact input 1 (DI1)
8	External contact input 2 (DI2)
9	External contact input 3 (DI3)
10	0V (External input)
11	0V (External input)
12	0V (External input)

* Pins 10-12 are internally connected.

Pin No.	Contents
1	Digital output 1 (DO1) : Relay contact output
2	Digital output 2 (DO2) : Relay contact output
3	COM : Common

• Auto setting (With gradient setter)

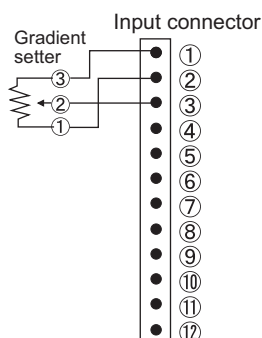

• Auto/Manual setting selection

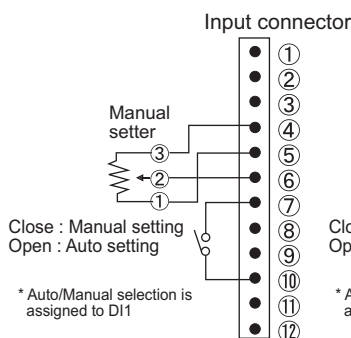

• Auto/Manual setting selection (With gradient setter)

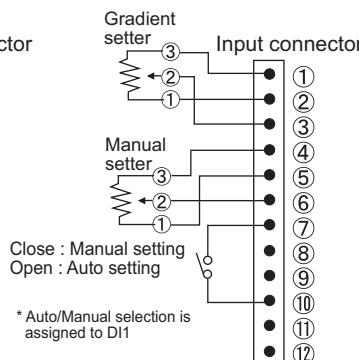

• Manual setting (With manual setter)

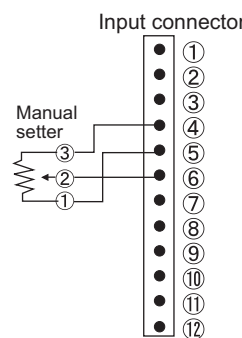

• External contact input

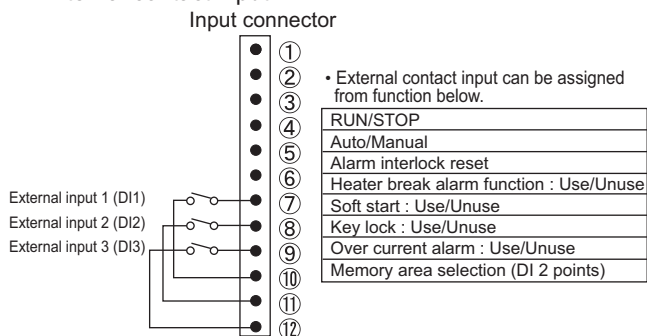

• Alarm output

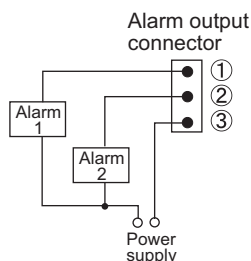

Power Controller THV-A1 Series



Accessories

- Gradient setter, Manual setter, High/Low setter : THVP-S01 Unit : mm

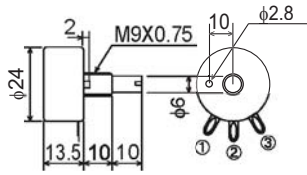

Volume (Resistance:5kΩ,B)

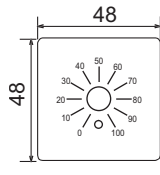

Scale plate

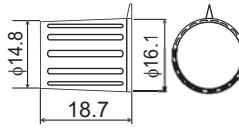

Knob

- RS-422A Communication cable

Model Code :
 W-BF-02-500 (0.5m)
 W-BF-02-1000 (1m)
 W-BF-02-3000 (3m)

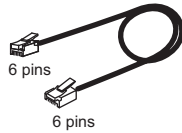

6 pins

6 pins

- Termination resistor connector

Model : W-BW-01
 (For RS-485)

Model : W-BW-02
 (For RS-422A)

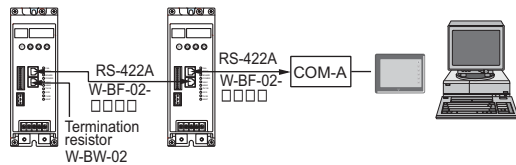

- Model code * Please refer to the following codes to order accessories.

Name	Model Code
Setter	THVP-S01
Input connector (plug)	THWP-C01
Alarm output connector (plug)	THVAP-C01

Name	Model Code	
Fast-blow fuse	20A	THVAP-F20
	30A	THVAP-F30
	45A	THVAP-F45
	60A	THVAP-F60
	80A ^{*1}	THVAP-F45 (2 pieces)
	100A ^{*1}	THVAP-F60 (2 pieces)
	150A ^{*1}	THVAP-FB0 (2 pieces)
	200A ^{*1}	THVAP-FC0 (2 pieces)

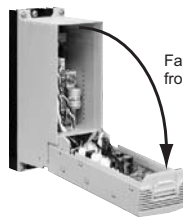

Fast-blow fuse can replace from the front.

^{*1} : A fast-blow fuse for 80A uses two 45A rapid blow fuses (THVAP-F45).
 A fast-blow fuse for 100A uses two 60A rapid blow fuses (THVAP-F60).
 A fast-blow fuse for 150A, 200A uses two rapid blow fuses (150A:THVAP-FB0, 200A:THVAP-FC3).