

REX - B850

INSTRUCTION MANUAL

IM850B01 - E2

Before using this product, please carefully read this manual for its correct use. In addition, after reading the manual keep it available easily anytime.

- This manual is subject to change without prior notice.
- This manual may not be reproduced or copied in whole or in part without RKC's prior consent.
- This manual and the REX-B850 manufactured, prepared, then shipped under strict quality control. However, if any defect is found, please contact your nearest RKC sales office or agent from which you bought the product.
- RKC assume no responsibility for any of the following damage which the user or third party may suffer.
 - ① Damages incurred as result of using this product.
 - ② Damages caused by product failure which cannot be predicted by RKC.
 - ③ Other indirect damages.

CONTENTS

1. PRODUCT CHECK.....	1
2. NAME OF PARTS.....	3
3. MOUNTING.....	4
4. WIRING AND CONNECTION.....	5
5. OPERATIONS.....	9
6. SETTING FOR COMMUNICATION	9
7. COMMUNICATION PROTOCOL	10
8. COMMUNICATION IDENTIFIERS	13
9. COMMUNICATIONS DATA CONFIGURATION.....	15
10. INITIALIZE SETTING	16
11. SPECIFICATIONS	20
12. DESCRIPTION OF EACH FUNCTION	22
13. TROUBLESHOOTING	27
14. CODE TABLE	28

▶ MARKING CAUTIONS ◀

For safe operation of "REX-B850", the following "Signal Words and Symbol Marks" are used in this manual.

<Signal Words>

WARNING :

Where there are possible dangers such as electric shock, fire (burns), etc. which could cause loss of life or injury, precautions to avoid such dangers are described.

CAUTION :

These describe precautions to be taken if unit damage may result if operating procedures are not strictly followed.

NOTE :

Extra notes or precautions are added to operating procedures and explanations.

<Symbol Marks>

- ⚠ : This mark is used when great care is needed especially for safety.
- *

WARNING

●Wiring precautions

- If failure or error of this instrument could result in a critical accident of the system, install an external protection circuit to prevent such an accident.
- In order to prevent instrument damage or failure, protect the power line and the input/output lines from high currents by using fuses with appropriate ratings.

●Power supply

- In order to prevent instrument damage or failure, supply power of the specified rating.
- In order to prevent electric shock or instrument failure, do not turn on the power supply until all of the wiring is completed.

●Never use the instrument near inflammable gases

- In order to prevent fire, explosion or instrument damage, never use this instrument at a location where inflammable or explosive gases or vapour exist.

●Never touch the inside of the instrument

- In order to prevent electric shock or burns, never touch the inside of the instrument. Only RKC service engineers can touch the inside of the instrument to check the circuit or to replace parts. High voltage and high temperature sections inside the instrument are extremely dangerous.

●Never modify the instrument

- In order to prevent accident or instrument failure, never modify the instrument.

●Maintenance

- In order to prevent electric shock, burns or instrument failure, only RKC service engineers may replace parts.
- In order to use this instrument continuously and safely, conduct periodic maintenance. Some parts used in this instrument have a limited service life and may deteriorate over time.

1. PRODUCT CHECK

Check whether the delivered product is as specified by referring to the following model code list.

■ Model code

REX-B850-□□□□-D□□*□-□-□-□
 ①②③④ ⑤⑥⑦ ⑧ ⑨ ⑩ ⑪

- ① Number of channel. . . . 4 : 4 channel, 6 : 6 channel, 8 : 8 channel
- ② Control action. . . F : Brilliant PID action with AT
W : Heating/cooling brilliant PID action with AT
- ③ Input type. . . See the input range code table.
- ④ Input range. . . See the input range code table.
- ⑤ Heating output . . . D : Open collector output
- ⑥ Cooling output . . . N : None, D : Open collector output
- ⑦ Power type 3 : 24 V AC/DC, 4 : 100 to 240 V AC
- ⑧ First alarm, ⑨ Second alarm. . . See the alarm action type.
- ⑩ CT type. N : None, P : CTL-6-P-N,
S : CTL-12-S56-10L-N
- ⑪ Communication function. . . 4 : RS-422A, 5 : RS-485,
6 : RS-232C

*If W action (Heating/cooling control) is selected, number of input channel becomes 4 channels.

- ◎ Confirm that the address (RS-422A/RS-485), communication speed and bit configuration are as specified.

Accessories

- Instruction manual [IM850B01-E2] (1 copy)

<Input range table>

Input type	Range	Code	
		*2	*3
K	0 to 200 °C	K01	K29
	0 to 400 °C	K02	K09
	0 to 800 °C	K04	K10
	0 to 1300 °C	K11	K23
	-50 to +150 °C	K24	K30
	-200 to +200 °C	K25	K31
	-200 to +300 °C	K26	K32
	-200 to +600 °C	K27	K33
	-200 to +1300 °C	K28	K34
	0 to 800 °F	KA1	KA4
0 to 2400 °F	KA5	KB4	
J	0 to 200 °C	J01	J22
	0 to 400 °C	J02	J08
	0 to 600 °C	J03	J23
	0 to 800 °C	J04	J09
	0 to 1200 °C	J06	J16
	-50 to +150 °C	J17	J24
	-200 to +200 °C	J18	J25
	-200 to +300 °C	J19	J26
	-200 to +400 °C	J20	J27
	-200 to +600 °C	J21	J28
	-200 to +1200 °C	J15	J29
	0 to 700 °F	JB3	JA4
	0 to 1600 °F	JB4	JB2
	0 to 2100 °F	JA5	JB5
R	0 to 1700 °C	R03	R05
	0 to 3000 °F	RA3	RA4
S	0 to 1700 °C	S03	S04
	0 to 3000 °F	SA3	SA4
B *1	0 to 1400 °C	B05	B06
	0 to 1800 °C	B03	B04
	0 to 2500 °F	BA6	BA7
	0 to 3000 °F	BA5	BA8
E	0 to 200 °C	E09	E15
	0 to 400 °C	E04	E07
	0 to 700 °C	E10	E03
	0 to 1000 °C	E02	E08
	-50 to +150 °C	E11	E16
	-200 to +200 °C	E12	E17
	-200 to +300 °C	E13	E18
	-200 to +400 °C	E14	E19
	-200 to +1000 °C	E06	E20
	0 to 1800 °F	EA3	EA6
T	0 to 200 °C	T09	T12
	0 to 400 °C	T08	T06
	-50 to +150 °C	T14	T17
	-200 to +200 °C	T10	T13
	-200 to +300 °C	T15	T18
	-200 to +400 °C	T16	T19
	0 to 700 °F	TA9	TA7
	-200 to +400 °F	TB4	TB6

Input type	Range	Code		
		*2	*3	
T	-300 to +400 °F	TB1	TB3	
	-300 to +700 °F	TB5	TB7	
N	0 to 1300 °C	N02	N05	
	0 to 2300 °F	NA1	NA4	
PL II	0 to 1300 °C	A01	A05	
	0 to 2300 °F	AA3	AA5	
W5Re/ W26Re	0 to 1200 °C	W05	W06	
	0 to 2300 °C	W03	W04	
	0 to 2200 °F	WA5	WA6	
	0 to 3000 °F	WA3	WA7	
U	0 to 200 °C	U10	U14	
	0 to 400 °C	U05	U03	
	0 to 600 °C	U08	U04	
	-200 to +200 °C	U06	U09	
	-200 to +300 °C	U11	U15	
	-200 to +400 °C	U12	U16	
	-200 to +600 °C	U13	U17	
	0 to 1100 °F	UA4	UB1	
	-300 to +400 °F	UA6	UA9	
L	0 to 200 °C	L06	L13	
	0 to 400 °C	L01	L03	
	0 to 600 °C	L07	L14	
	0 to 900 °C	L05	L04	
	-200 to +200 °C	L08	L15	
	-200 to +300 °C	L09	L16	
	-200 to +400 °C	L10	L17	
	-200 to +600 °C	L11	L18	
	-200 to +900 °C	L12	L19	
	0 to 1600 °F	LA2	LA6	
	-300 to +400 °F	LA7	LA8	
	JPt100	-100 to +100 °C	P23	P04
		-200 to +500 °C	P24	P25
		-150 to +200 °F	PB9	PB1
-200 to +900 °F		PC1	PC2	
Pt100	-100 to +110 °C	D23	D04	
	-200 to +600 °C	D24	D25	
	-150 to +200 °F	DB9	DB1	
	-200 to +1000 °F	DC1	DC2	

*1 : Accuracy in the range of 0 to 400 °C (0 to 800 °F)
: Not guaranteed.

*2 : Without decimal point

*3 : With decimal point

<Alarm action type>

- | | |
|---|---|
| N : No alarm | F : Deviation low alarm with hold action |
| A : Deviation high alarm | G : Deviation high and low alarm with hold action |
| B : Deviation low alarm | H : Process high alarm |
| C : Deviation high and low alarm | J : Process low alarm |
| D : Band alarm | K : Process high alarm with hold action |
| E : Deviation high alarm with hold action | L : Process low alarm with hold action |

2. NAME OF PARTS

TC input type

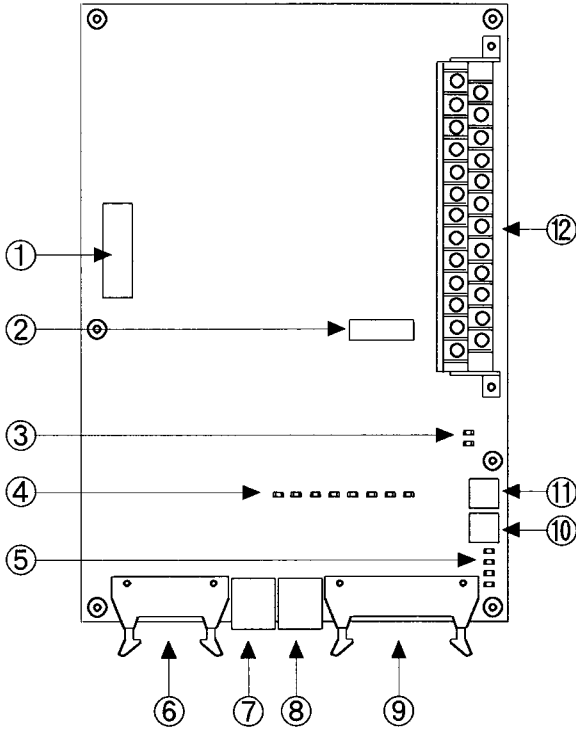

- ① Model code seal
- ② Data type setting switch (SW103)
- ③ Data sending/receiving display LED
 - Data sending display LED (Yellow)
 - Data receiving display LED (Yellow)
- ④ Control output display LED
 - Heating control action type : 8 points (Green)
 - Heating/cooling control action type :
 - Heating side : 4 points (Green)
 - Cooling side : 4 points (Green)

- ⑤ Power/FAIL/Alarm display LED
 - Power display LED (Green)
 - FAIL display LED (Red)
 - First alarm display LED (Red)
 - Second alarm display LED (Red)

RTD input type

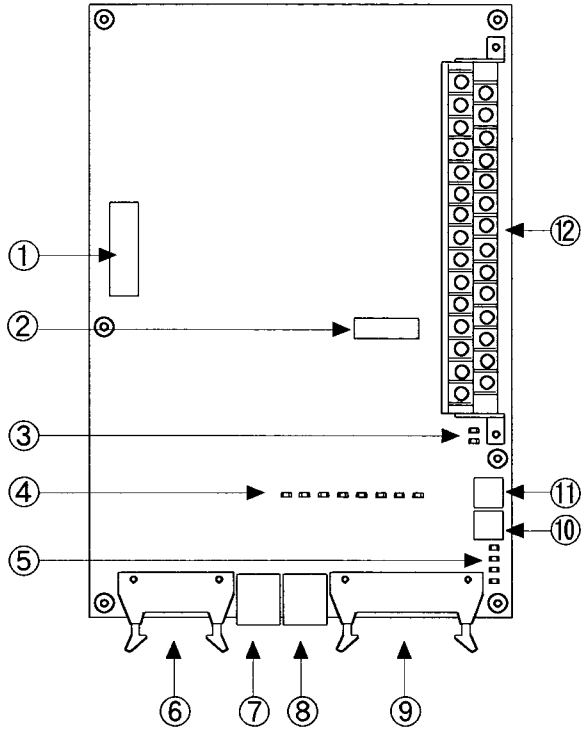

- ⑥ Current transformer (CT) input connector
- ⑦ Modular connector for communication
- ⑧ Multi-drop connection modular connector
- ⑨ FAIL/alarm/control output connectors
- ⑩ Communication speed setting switch (SW101)
- ⑪ Device address setting switch (SW102)
- ⑫ Terminal block

3. MOUNTING

⚠ WARNING

⚡ In order to prevent electric shock or instrument failure, do not turn on the power supply until all of the wiring is completed.

3.1 Cautions for Mounting ⚠

Avoid the following when selecting the mounting location.

- Ambient temperature of less than 0 °C (32 °F) or more than 50 °C (122 °F).
- Ambient humidity of less than 45% or more than 85% RH .
- Rapid changes in ambient temperature which may cause condensation.
- Corrosive or inflammable gases.
- Direct vibration or shock to the mainframe.
- Water, oil, chemicals, vapor or steam splashes.
- Excessive dust, salt or iron particles.
- Excessive induction noise, static electricity, magnetic fields or noise.
- Direct air flow from an air conditioner.
- Should be used indoors where the system is not exposed to direct sunlight.
- Heat to be accumulated radiation heat.

3.2 Mounting Angle ⚠

Since mercury relays are used for this controller, do not slant the controller more than 30 ° in all directions. If so, the controller may malfunction.

Front

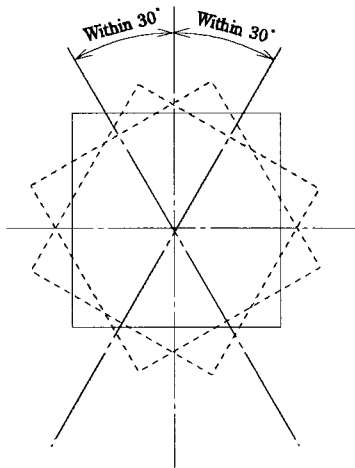

Side

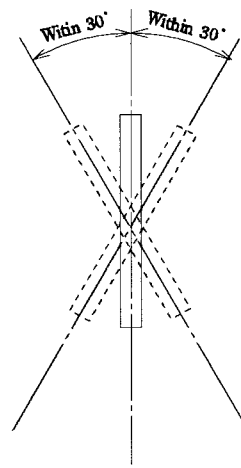

3.3 Dimensions

External dimensions

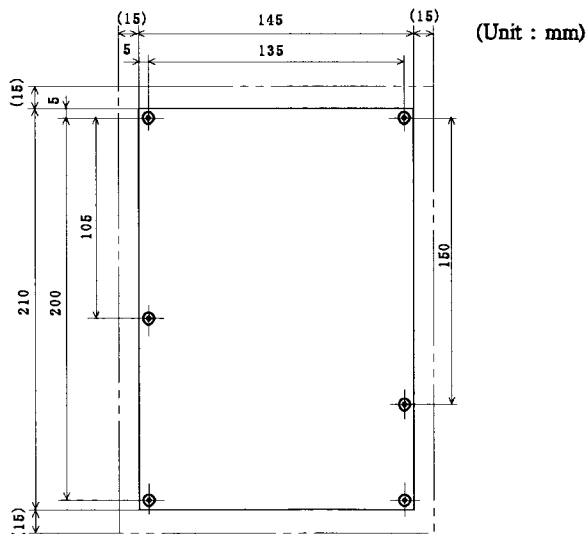

Mounting drawing

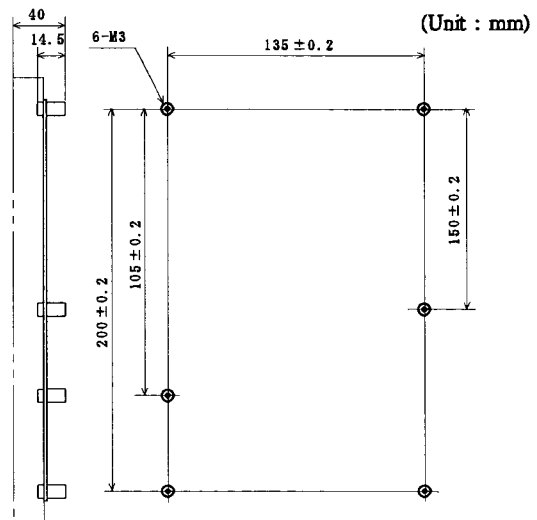

*Dimensions indicated by each 2-dot chain line : Maximum dimensions including those of connector and installed parts.
 *Air spacing, for protection against being filled with heat, shall be larger than the maximum dimensions specified with the 2-dot chain line.

4. WIRING AND CONNECTION

⚠ WARNING

- In order to prevent electric shock or instrument failure, do not turn on the power supply until all of the wiring is completed.
- In order to prevent electric shock or instrument failure, connect or disconnect the connector after turning off the power to this module and peripheral equipment.
- If failure or error of this instrument could result in a critical accident of the system, install an external protection circuit to prevent such an accident.
- In order to prevent instrument damage or failure, protect power line and the input/output lines from high currents by using fuses with appropriate ratings.

4.1 Cautions For Wiring ⚠

Grounding— wire wiring

- Do not ground the instrument together with other equipment.
- Do not mix this grounding wire with other grounding wires.
- For instrument to the earth through the shortest route possible using an electric wire a nominal conductor cross section of 2.0 mm² or larger.
[Grounding resistance : Less than 100 Ω]

Power supply wiring

- Use the power supply within its voltage variation range.

Power voltage	Voltage variation range
100 to 240 V AC	90 to 264 V AC
24 V AC	21.6 to 26.4 V AC
24 V DC	21.6 to 26.4 V DC

- In case of the 24V modules, use only a power supply properly separated from hazardous voltages.
- Use power supply wires, use 600 V Polyvinyl chloride insulated wires (JIS C3307). Also use wires that have small voltage drop.
- Conduct instrument power wiring so as not to be influenced by noise from the electric equipment power. If it is assumed that a noise generation source is located near the controller and the controller is influenced by noise, use a noise filter.

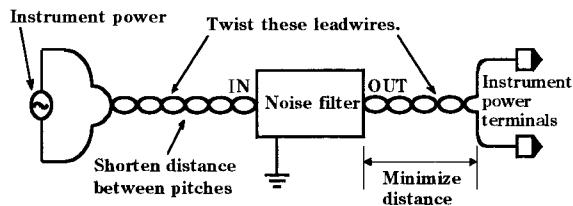

Measures for suppressing noise

- Shorten the distance between twisted power supply wire pitches. The shorter the distance between the pitches, the more effective for noise reduction.
- Install the noise filter on the panel which is always grounded and minimize the wiring distance between the noise filter output side and the instrument power terminals. Otherwise, the longer the distance wiring, the less effective for noise.
- To obtain a satisfactory noise filter effect, select the most suitable type after due consideration of instrument power supply voltage and filter frequency characteristics.

Input/output signal wiring

- For TC input, use the compensation wire.
- For RTD input, use leads with low resistance and having no resistance differences between the 3 leads.
- Conduct input signal wiring away from instrument power, electric equipment power and load lines as such as possible to avoid noise induction.

Others

- When connecting wires, note that the power, input/MCU and output circuits are isolated independently, while the inside of the input and output circuits are not isolated.
- If two or more REX- B850s are closely mounted, take care that the signal and power lead wires do not contact the printed wiring board of each REX- B850.
- This instrument had no power supply switch nor fuses. Therefore, install the fuse close to the instrument and the switch, if required.
 - Recommended fuse rating : Rated voltage ; 250 V
Rated current ; 1 A
 - Fuse type : Time-lag fuse
- This instrument is intended to be used under the following environmental conditions. (IEC1010)
 - OVERVOLTAGE CATEGORY II
 - POLLUTION DEGREE 2

4.2 Connecting Precautions ⚠

- Connect the connector correctly in the right position. If it is forcibly pushed in with pins in the wrong positions, the pins may be bent resulting in instrument failure.
- When connecting or disconnecting the connector, do not force it too far to the right and left or up and down, but move it as straight as possible. Otherwise, the connector pins may be bent, causing instrument failure.
- Disconnect the connector while holding the connector itself. Do not disconnect the connector while pulling out the connector cable, since this may cause instrument failure.
- Do not touch the contact surfaces of the connector with bare hands or hands stained with oil, etc. Malfunction may result.
- Connect only to equipment which provide sufficient separation from the live hazardous voltages (approved types).

4.3 Terminal And connector Description

Terminal Configuration

CAUTIONS

- For TC input, a temperature compensator is attached between terminals Nos. 13 and 15. When connecting or wiring the input wires, be careful not damage the compensator.
- Short each unused TC input channel. If the instrument is used with this channel opened, the burnout or alarm function may be activated.
- Connect a 100 Ω resistor between adjacent terminals A and B and short terminal B with terminal B for each unused RTD channel. If the instrument is used with these terminals opened, the burnout or alarm function may be activated.
- Firmly tighten each terminal screw. Otherwise, malfunction may result.

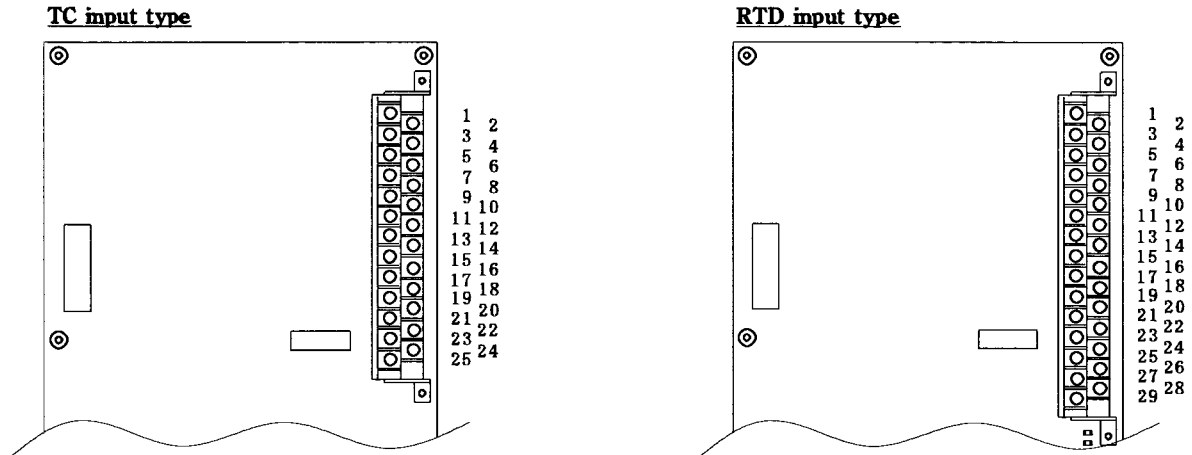

COMMON:

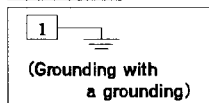

Power Δ

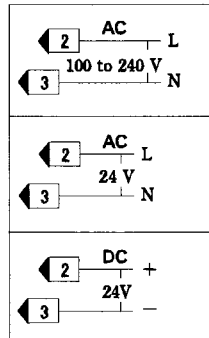

TC input type:

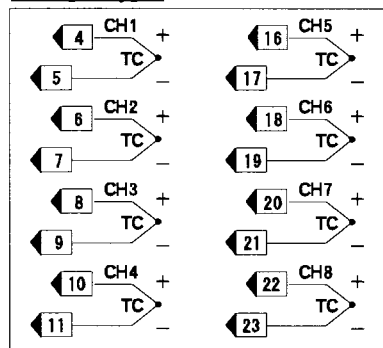

Event input

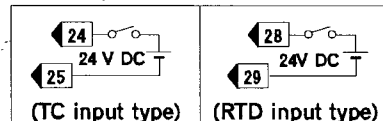

RTD input type:

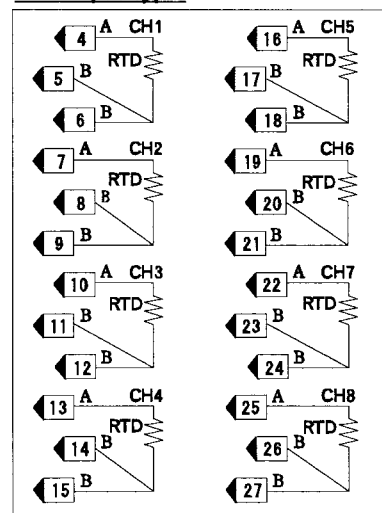

- **Grounding terminal (No. 1 terminal)**
This is grounding terminal for prevent electric shock. Use grounding wires with a cross section of 2 mm² or more, and ground this grounding wire.
- **Power terminals (Nos. 2 and 3 terminals)**
Power input terminals. Confirm that power voltage is also the same as that specified when ordering.
- **Input terminal**

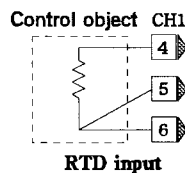
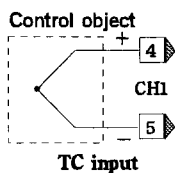

- **Event input terminal**
External power (24 V DC) supply is required.

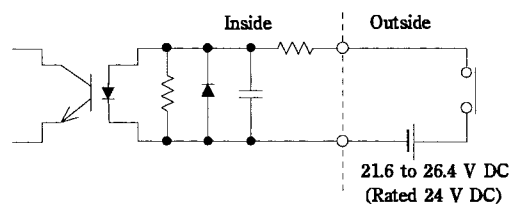

Event input circuit

NOTES

- A screw is left as is in each unused terminal.
- M3 size self-urping terminal screws are used. It is recommended that crimp-style terminal lugs be used for terminal connection. Use crimp-style terminal lugs of 6 mm or less.

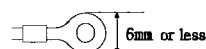

Recommended tighten torque : 0.4 N · m (4kgf · cm)
Maximum allowance tighten torque : 1.0 N · m (10kgf · cm)

■ Connector Configuration

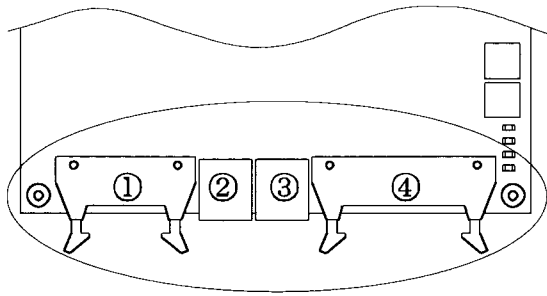

Connector pin No.

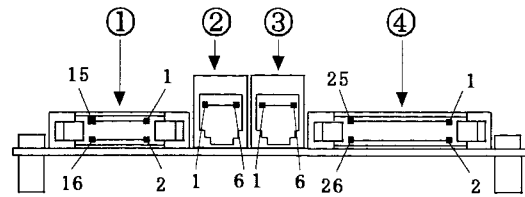

① CT input connector

Pin No.	Description
1	CT1
2	
3	CT2
4	
5	CT3
6	
7	CT4
8	
9	CT5
10	
11	CT6
12	
13	CT7
14	
15	CT8
16	

② Communication modular connector

Pin No.	Description		
	RS-422A	RS-485	RS-232C
1	RA	RA/TA	Unused
2	RB	RB/TB	SD
3	SG	SG	SG
4	TB	Unused	RD
5	TA		Unused
6	Unused		

③ Multi-drop connection modular connectors

Pin No.	Description	
	RS-422A	RS-485
1	RA	RA/TA
2	RB	RB/TB
3	SG	SG
4	TB	Unused
5	TA	
6	Unused	

④ Output connector

Pin No.	Description	
1	(+)	First alarm output
2	(-)	
3	(+)	Second alarm output
4	(-)	
5	(+)	Fail output
6	(-)	
7	(+)	Heating output (CH1)
8	(-)	Heating output (CH1)
9	(+)	Heating output (CH2)
10	(-)	Heating output (CH2)
11	(+)	Heating output (CH3)
12	(-)	Heating output (CH3)
13	(+)	Heating output (CH4)
14	(-)	Heating output (CH4)
15	(+)	Heating output (CH5)
16	(-)	Cooling output (CH1)
17	(+)	Heating output (CH6)
18	(-)	Cooling output (CH2)
19	(+)	Heating output (CH7)
20	(-)	Cooling output (CH3)
21	(+)	Heating output (CH8)
22	(-)	Cooling output (CH4)
23		Unused
24		
25		
26		

NOTES

- A cable and connector for connecting is necessary to be prepared by the customer.

Recommended connector list

Connector name	Recommended connector
① CT input connector	AXM116415 (Manufactured by Panasonic Co., Ltd)
② Communication modular connector	TM4P66P01-KSFN □□□□ (Type with one-sided plug) or TM4P66PP-KSFN □□□□ (Type with double-sided plug)
③ Multi-drop connection modular connectors	
④ Output connector	AXM126415 (Manufactured by Panasonic Co., Ltd)

- **Output connector (Open collector output)**
26 pin type connector for alarm output, fail output and control output.

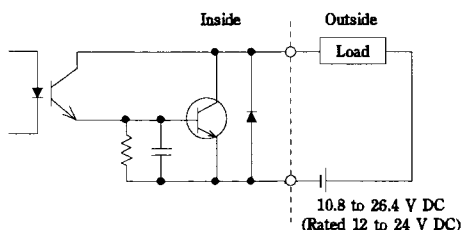

Open collector output circuit

- **CT input connector (Option)**
Always connect the specified current transformer.
Recommended connector :
CTL-6-P-N (Input range 0 to 30A)
CTL-12-S56-10L-N (Input range 0 to 100A)

- **Communication modular connector *1**
Connector for connection with host computer (or communication level converter).

- **Multi-drop connection modular connector *1**
Modular connector for multi-drop connection.

***1 Modular connector connection**

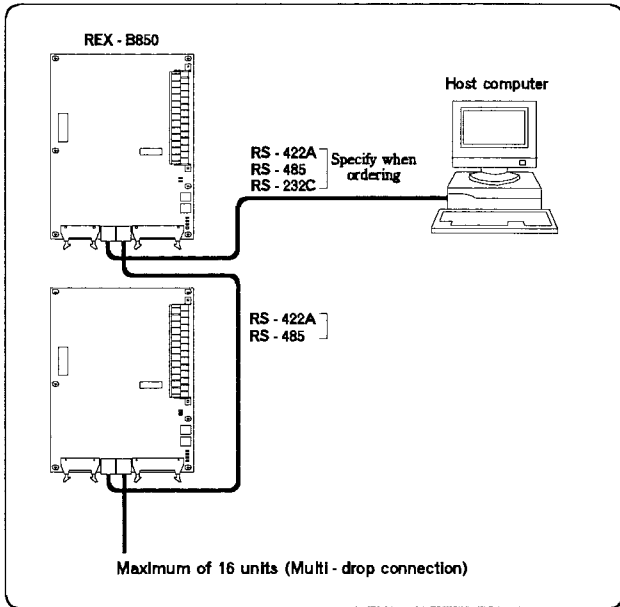

Specifications conforming to RS-485

● Pin arrangement and signal names

Pin No.	Symbol	Name	Direction of signal	
			B850	Host
1	T/R (A)	Send/receive data	↔	
2	T/R (B)	Send/receive data	↔	
3	SG	Signal ground	—	

● Communication cable core connecti

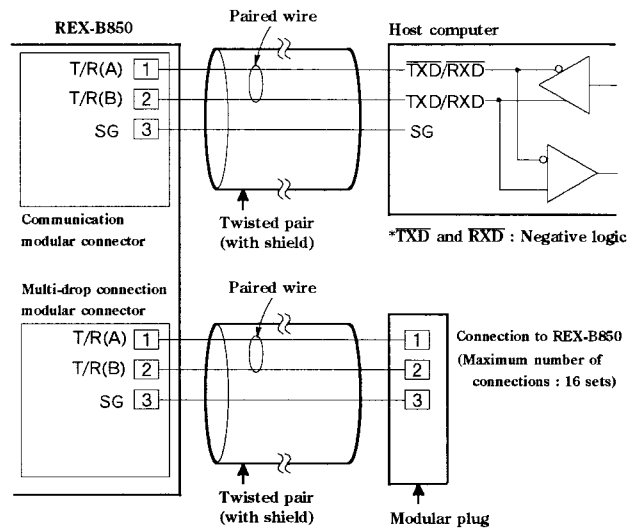

Specifications conforming to RS-422A

● Pin arrangement and signal names

Pin No.	Symbol	Name	Direction of signal	
			B850	Host
5	T (A)	Send data	→	
4	T (B)	Send data	→	
3	SG	Signal ground	—	
1	R (A)	Receive data		←
2	R (B)	Receive data		←

● Communication cable core connection

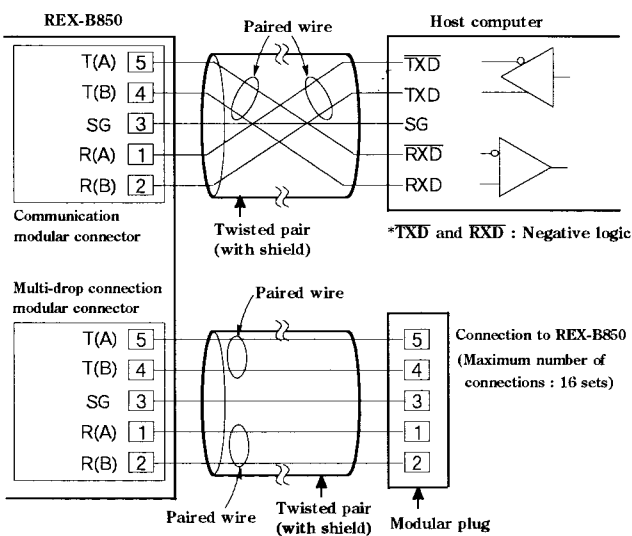

Specifications conforming to RS-232C

● Pin arrangement and signal names

Pin No.	Symbol	Name	Direction of signal	
			B850	Host
2	SD (TXD)	Send data	→	
4	RD (RXD)	Receive data		←
3	SG (GND)	Signal ground	—	

● Communication cable core connection

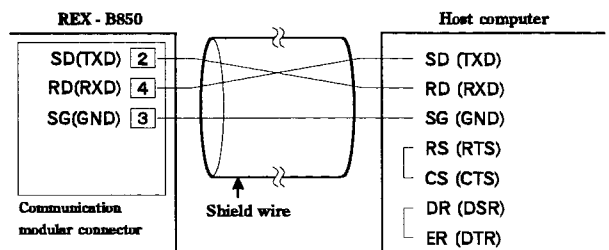

NOTE

● When using our signal level converter (separately sold), please also read the instruction manual for "Signal level converter".

5. OPERATION

5.1 Operation Procedure

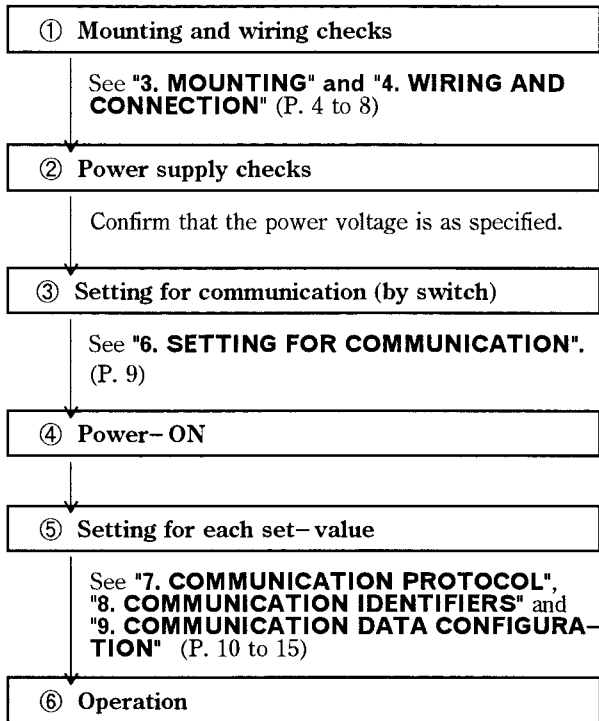

5.2 Cautions for Operation

- Connect the input signal line, and then turn ON the power. When the input signal line opens, this is determined to be input break by the controller and as a result the measured-value goes upscale or downscale.
Upscale . . . TC input and RTD input
Downscale . . . RTD input (When shorted)
- Do not use the auto-tuning function in a control system where hunting causes trouble. In this case, set each PID constant appropriate to the controlled object.
- No influence is exerted upon the controller for power failure of less than 50 ms. For power failure of more than 50 ms, the controller performs the same operation as that at the time of power-ON after power recovery.

6. SETTING FOR COMMUNICATION

6.1 Switch Setting

Prior to communication start, check the data format, communication speed and device address. Change these settings to meet your specifications. For the switch position, see "2. NAME OF PARTS". (P. 3)

CAUTIONS

- Prior to conducting the setting, always turn OFF the power. Otherwise the instrument does not operate normally.
- Do not change the setting of any switch marked "Unused" among the switches (SW101, SW102 and SW103). Otherwise instrument damage or malfunction may result.
- Any setting which does not meet the specification may cause malfunction.

■ Data Type Setting

The data format is set by data type setting switch (SW103).

*Each shaded section indicates the setting when not specified by the customer prior to factory shipment.

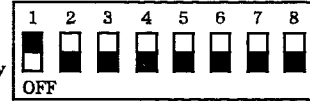

Data bit	7 bit	ON						
	8 bit	OFF						
Parity bit	No parity	ON						
	Parity	OFF						
Selection of odd or even number	Even number	ON						
	Odd number	OFF						
Stop bit	1 bit	ON						
	2 bit	OFF						
Unused (Setting cannot be changed)							OFF only	
Mode change	Initial mode							ON
	Normal mode							OFF

■ Device Address Setting

The device address is set by device address setting switch (SW102).

CAUTION

- Set the device address such that is different to the other address on the same line. Otherwise, problems or malfunction may result.

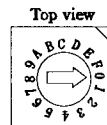

Setting	Device address	Setting	Device address
0	Device address 00 *	8	Device address 08
1	Device address 01	9	Device address 09
2	Device address 02	A	Device address 10
3	Device address 03	B	Device address 11
4	Device address 04	C	Device address 12
5	Device address 05	D	Device address 13
6	Device address 06	E	Device address 14
7	Device address 07	F	Device address 15

*When not specified by the customer prior to factory shipment :
Device address 00

■ Communication Speed Setting

The communication speed is set by communication speed setting switch (SW101).

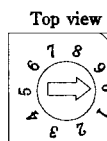

Setting	Communication speed
0	19200 bps *
1	9600 bps
2	4800 bps
3	2400 bps

*When not specified by the customer prior to factory shipment : 19200 bps

CAUTION

- Nos. 4 to 9 cannot be set. If set, normal communication cannot be made.

6.2 RS-485 (2-wire system) Send/Receive Timing

The transmission and reception of RS-485 communication are operated by a transmitting wire. Therefore, the timing of switching should be acted correctly.

Send/Receive Timing Example (Host computer and REX-B850 controller)

Polling procedure

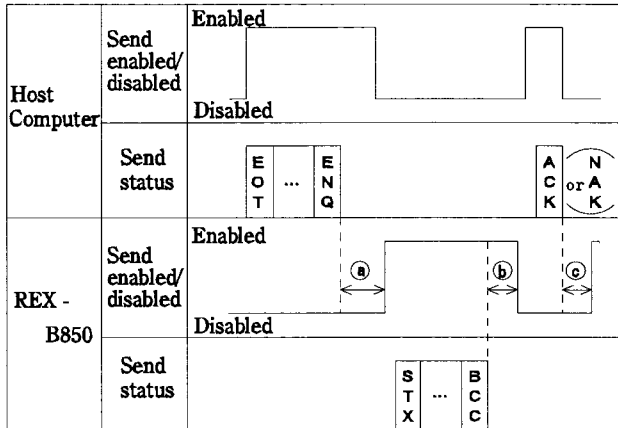

- Ⓐ: (Response send time after calling [ENQ] receive)
+ (Interval time)
- Ⓑ: Response wait time after BCC send
- Ⓒ: (Response send time after acknowledge [ACK] receive)
+ (Interval time)
- or
- (Response send time after negative acknowledge [NAK] receive) + (Interval time)

Selecting procedure

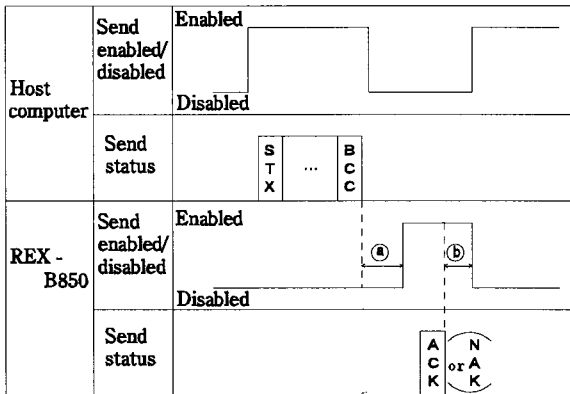

- Ⓐ: (Response send time after BCC receive)
+ (Interval time)
- Ⓑ: Response wait time after acknowledge [ACK] send
- or
- Response wait time after negative acknowledge [NAK] send

NOTES

- When changing the host computer from send to receive, set the interval time to match that of the host computer. If the interval time is not set correctly, the REX-B850 side is set to send mode before all the data is sent from the host computer; therefore correct communication is not possible.

Interval time :

Time until the transmission line is switched to the receive side (until data send of the REX-B850 is enabled) after the host computer has sent the final character stop bit.

- Change the host computer from receive to send mode after the following processing time has elapsed.

Polling procedure :

Response wait time after BCC is sent.

Selection procedure :

Response wait time after acknowledge [ACK] is sent, or Response wait time after negative acknowledge [NAK] is sent.

7. COMMUNICATION PROTOCOL

REX-B850 adopted polling/selection type for the method of establish data link. The basic procedure is followed ANSI X3.28 subcategory 2.5, A4 and JIS basic mode data transmission control procedure (First selecting is established for selection).

- The polling/selection method is such that all REX-B850s are controlled by the host computer and REX-B850s is permitted. In order to force REX-B850 to send and receive data messages, send the messages from the host computer according to the polling or selection procedure. (Centralized control method)
- The code use in communication is 7-bit JIS/ASCII code including transmission control character.

[The transmission control characters]

[EOT] (04H), [ENQ] (05H), [ACK] (06H), [NAK] (15H), [STX] (02H), [ETX] (03H)

*() : Hexadecimal number.

7.1 Polling

Polling is an action that host computer requesting one of the REX-B850 which selected among multi-drop connected, to send the data. The procedure is as the following.

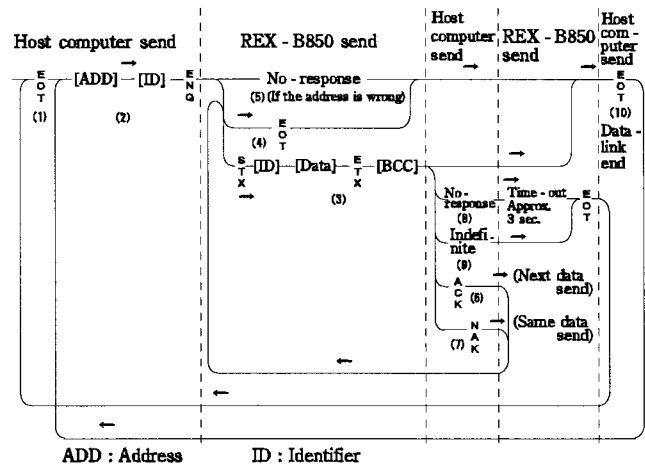

Polling Procedure

(1) Initialize of data link

Host computer sends [EOT] for initializing of data link before polling sequence.

(2) Polling sequence send

Host computer sends polling sequence with a format shown below.

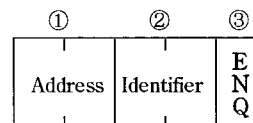

① Address

This address is a device address of the REX-B850 for polled. Must be the same device address as that set by device address setting switch. Expressed by decimal 2-digit ASCII code (00 to 15).

② **Identifier** (See P. 13)

This is for identifying code required to send to REX-B850. Expressed by decimal 2-digit alphanumeric ASCII code.

③ **[ENQ]**

This is the transmission control character which indicates the end of the polling sequence. Then, the host computer waits for response from the REX-B850.

(3) **Controller data sending**

If the polling sequence is received correctly, the REX-B850 sends data in the following format.

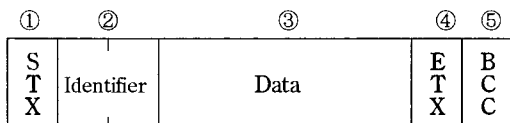

① **[STX]**

This is the transmission control character which indicates the start of the text (identifier and data).

② **Identifier** (See P. 13)

This is for identifying code sent to the host computer. Expressed by decimal 2-digit alphanumeric ASCII code.

③ **Data**

This is the data indicated by the identifier of REX-B850. This is configured by channel No., data etc. Each channel No. and data are delimited by space code (20H). Each data is marked off by a comma.

NOTE

- The number of data digits (length) and structure vary depending on the type of identifier. (See P. 15)

④ **[ETX]**

This is the transmission control character which indicates the end of the text.

⑤ **[BCC]**

[BCC] (Block Check Character) for error detection using horizontal parity. BCC is calculated by horizontal parity (even number).

<Algorithm>

[BCC] is the result calculated using exclusive "OR" (EX-OR) of all characters from the character next to [STX] to [ETX]. Not including [STX].

- Example -

In the case of the data are :

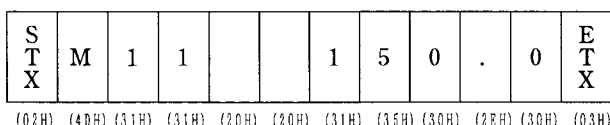

$BCC = 4DH \oplus 31H \oplus 31H \oplus 20H \oplus 20H \oplus 31H \oplus 35H \oplus 30H \oplus 2EH \oplus 30H \oplus 03H = 64H$ ("⊕" indicates EX-OR)

Value of BCC becomes 64H.

(4) **REX-B850 data sending end (EOT sending)**

REX-B850 sends [EOT] in the following cases to terminate the data link.

- When there is no specified identifier
- When the specified identifier is not valid
- When an error exists in the data format
- When all data have been sent

(5) **No-response of REX-B850**

This REX-B850 does not respond if the polling sequence is not correctly received (if the address differs or data is not correct). In this case, take measures for recovery by time-out, etc. if necessary on the host computer side.

(6) **Acknowledgement [ACK]**

If the host computer correctly received data sent from REX-B850, send [ACK]. Then, REX-B850 sends identifier data next to the identifier just sent according to "8. COMMUNICATION IDENTIFIERS" (P. 13). When stopping sending data from REX-B850, send [EOT] from the host computer to terminate the data link.

(7) **Negative acknowledgement [NAK]**

If the host computer could not correctly receive data sent from REX-B850, send [NAK]. Then, REX-B850 resends the same data. As the number of times to resend is not specified, take an appropriate countermeasure for recovery on the host computer side if necessary.

(8) **No-response from host computer**

If the host computer send no-response, the REX-B850 sends [EOT] after the time-out time has elapsed to terminate the data link. (Time-out time : Approx. 3 sec.)

(9) **Indefinite response from host computer**

When the response from the host computer is indefinite, REX-B850 sends [EOT] to terminate the data link.

(10) **Data link termination [EOT]**

If it is necessary to suspend communication with REX-B850 or to terminate the data link due to no-response from REX-B850, the host computer sends [EOT].

■ **Polling Procedure Example**

(When the host computer requests data)

Normal transmission

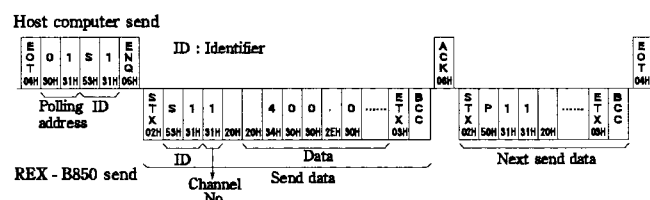

For the presence of error in data

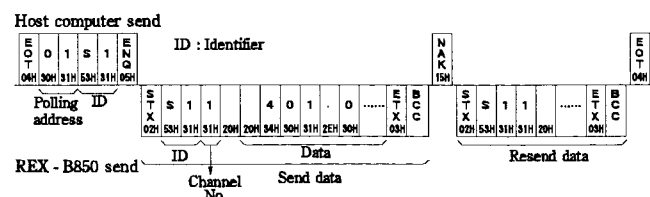

7.2 Selection

Selection is an operation in which the host computer selects one set from among REX-B850s multi-drop connected and then of recommending data receive. The procedure is as the following.

Due to adopted fast selecting in REX-B850 therefore becomes the type to send the data which connected to selection sequence.

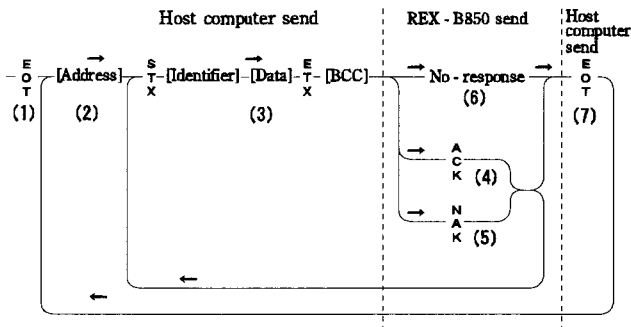

■ Selection Procedure

(1) Data link initialize

In order to initialize the data link before sending the selecting sequence, send [EOT] from the host computer.

(2) Selecting sequence sending

Send the selecting sequence from the host computer in the following format.

[Address]

This address is a device address of the REX-B850 for selected. Must be the same device address as that set by function switch 2.

Expressed by decimal 2-digit ASCII code (00 to 15).

(3) Data send

Host computer to send the data with a format indicated below continuing the selection sequence.

S T X	Identifier	Data	E T X	B C C
-------------	------------	------	-------------	-------------

(4) Acknowledgement [ACK]

If REX-B850 correctly received data sent from the host computer, send [ACK]. Then, if there is data to be sent next on the host computer side, send the data. After the data has been sent, send [EOT] to terminate the data link.

(5) Negative acknowledge [NAK]

REX-B850 sends [NAK] in the following cases.

Then the appropriate recovery processing steps, such as data resend on the host computer side should be taken.

- When an error occurs in the line (parity error or framing error)
- When a BCC check error occurs
- When there is no specified identifier
- When the specified identifier is not valid
- When an error exists in the data format
- When normal receive data exceeds the setting range

(6) No-response

If the selection address is not received correctly, REX-B850 is set to no-response.

(7) Data link termination [EOT]

When terminating the data link because there was no more to be sent on the host computer side or REX-B850 was set to no-response, send [EOT] from the host computer.

■ Selection Procedure Example

Normal transmission

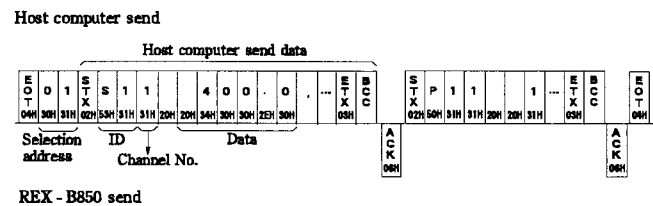

For the presence of error in data

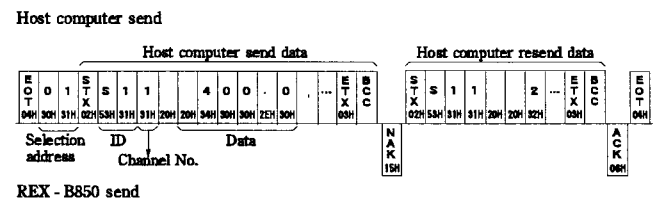

8. COMMUNICATION IDENTIFIERS

#1 : Attribute

(RO : Readout only RW : Readout and write are available WO : Write only)

No.	Name	Identifier	Dgt	#1	Data range	Description	Default value
1	Temperature measured- value (PV)	M1	6	RO	Input range	Used for monitoring measured - value (PV).	
2	First alarm status	AA	1	RO	0 : OFF 1 : ON	Used for monitoring first alarm status.	
3	Second alarm status	AB	1	RO	0 : OFF 1 : ON	Used for monitoring second alarm status.	
4	Burnout status	B1	1	RO	0 : Normal 1 : Burnout 2 : Burndown	Used for monitoring burnout status.	
5	Control output status (Heating- side)	O1	6	RO	0 to 100 % (Heating control) -5 to +105 % (H/C control)*	Used for monitoring control output.	
6	Control output status (Cooling- side) *1	O2	6	RO	-5 to +105 %		
7	Heater break alarm status *2	AC	1	RO	0 : Normal 1 : Heater break 2 : Weld relay contact	Used for monitoring heater break alarm status.	
8	Current transformer input value *2	M2	6	RO	CTL-6 type : 0.0 to 30.0 A CTL-12 type : 0.0 to 100.0 A	Heater break alarming value is set by referring to this value.	
9	PID/AT transfer	G1	1	RW	0 : PID 1 : Auto tuning (AT)	Selects PID control or AT to be performed. Selecting "1" immediately starts AT. Automatically turned to "0" at the end of AT.	0
10	Temperature set- value	S1	6	RW	Input range	Desired value control.	0.0
11	Proportional band (Heating- side)	P1	6	RW	0.0 to 1000.0 % (Heating control) 0.1 to 1000.0 % (H/C control)*	Set when PI or PID control is performed.	3.0
12	Proportional band (Cooling- side) *1	P2	6	RW	0.1 to 1000.0 %	Sets cooling- side proportional band when heating/cooling PID action is performed.	3.0
13	Integral time	I1	6	RW	0 to 3600 second (Heating control) 1 to 3600 second (H/C control)*	Sets the integral time to eliminate the offset produced in proportional action control.	240
14	Derivative time	D1	6	RW	0 to 3600 second	Sets the derivative time to prevent ripples and to stabilize control by predicting output changes.	60
15	Control response parameter	CA	1	RW	0 : SLOW 1 : MEDIUM 2 : FAST	Specifies the response caused by set- value changes in PID control.	2
16	Deadband *1	V1	6	RW	-10.0 to +10.0 %	Sets control deadband between heating- side and cooling- side proportional bands. Minus (-) setting results in overlap.	0.0
17	First alarm setting	A1	7	RW	· Deviation high alarm, Deviation low alarm : - span to +span · Deviation high and low alarm, Band alarm : 0 to span · Process alarm : Same as input range	Sets the first alarm set- value.	50.0
18	Second alarm setting	A2	7	RW		Sets the second alarm set- value.	-50.0

* : Heating/cooling control

(To be continue to next page.)

#1 : Attribute

(RO : Readout only RW : Readout and write are available WO : Write only)

No.	Name	Identifier	Dgt	#1	Data range	Description	Default value
19	Temperature control function selection	EI	1	RW	0 : Unused (Control output OFF, Alarm output OFF) 1 : Monitor (Control output OFF, Alarm output ON) 2 : Reverse action 3 : Direct action (Valid at heating-side control)	Selects the temperature control function. (Can be selected for each channel.)	2
20	Proportioning cycle (Heating-side)	T0	6	RW	1 to 100 second	Sets the control output period.	2
21	Proportioning cycle (Cooling-side) *1	T1	6	RW	1 to 100 second	Sets the cooling-side output period in heating/cooling PID action.	2
22	Heater break alarm set-value *2, *3	A3	6	RW	CTL-6 type : 0.0 to 30.0 A CTL-12 type : 0.0 to 100.0 A	Sets the heater break alarm set-value.	0.0
23	Control run/stop	X1	1	RW	0 : Control stop 1 : Control run	Selects whether control is required to run or stop.	1
24	PV bias	PB	6	RW	-5.00 to +5.00 %	Sets the bias added to the measured value to perform sensor correction.	0.00
25	Memory area execution No.	ZA	1	RW	1 to 8	Sets the memory area No. used for control.	1
26	Error code	ER	1	RO	0 : No error 1 : Backup data error 2 : RAM read/write error 3 : A/D converter error 4 : Adjustment data error 5 : System data error 6 : Channel selection error 7 : Output monitoring time exceeded	Displays the error No. corresponding to the content of the error produced.	
27	Output monitoring time	TU	6	RW	0 to 1440 minute	When a signal of 100% is continuously output, sets the output monitoring time until the above output signal is judged to fail. If the set value exceeds the output monitoring time, this is judged to fail.	60
28	Event function selection	XK	1	RW	0 : Unused 1 : Control stop command 2 : Event input monitor 3 : Memory area change command 4 : AT start command 5 : Control run/stop command 6 : Interlock release command	Select an event function from among the functions described on the left. * Selection is made between the area under control and memory area No. 8.	0
29	Event input status	L1	1	RO	0 : OFF 1 : ON	Displays the event input status. This display becomes possible when "2" is selected by event function selection.	
30	Alarm interlock release	AR	1	WO	1 : Release	Set when the alarm interlock is released.	

*1 : Valid only when heating/cooling control is available.

*2 : Option

*3 : ● Set heater break alarm set-value to a value about 85% current transformer input value (CT). However, when power supply variations are large, set the alarm to a slightly smaller value. In addition, when two or more heaters are connected in parallel, set the alarm to a slightly larger value so that it is activated even with only one heater is broken (However, within the value of CT).

● When the heater break alarm set-value is set to "0.0" or the current transformer is not connected, the heater break alarm is turned OFF.

9. COMMUNICATION DATA CONFIGURATION

There are several types of communication data configuration depending on the data length or presence or absence of channels. The configuration of communication data is shown below. A block excluding the [STX], [ETX] and [BCC] transmission control characters corresponds to the data block.

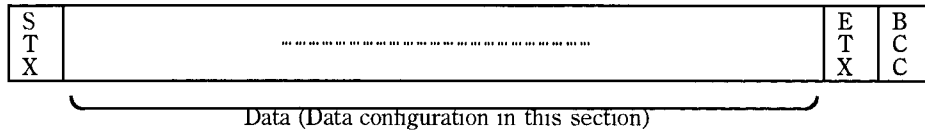

■ 1-Digit Data Length Type

(1) Data with channel No.

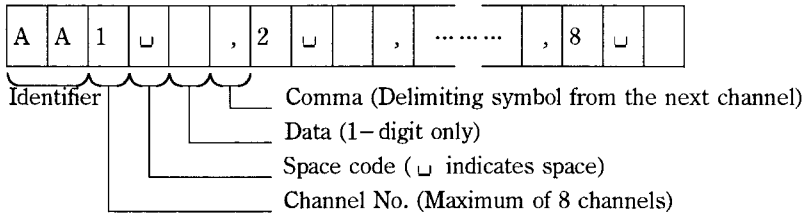

Identifier type

AA (First alarm status)	AB (Second alarm status)	B1 (Burnout status)
AC (Heater break alarm status)	G1 (PID/AT)	CA (Control response parameter)
EI (Temp. control function selection)		

(2) Data without channel No.

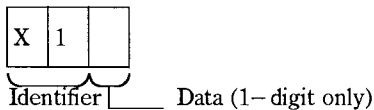

Identifier type

X1 (Control run/stop)	XK (Event function selection)
ZA (Memory are execution No.)	L1 (Event input status)
ER (Error code)	AR (Alarm interlock release)

■ 6-Digit Data Length Type

(1) Data with channel No.

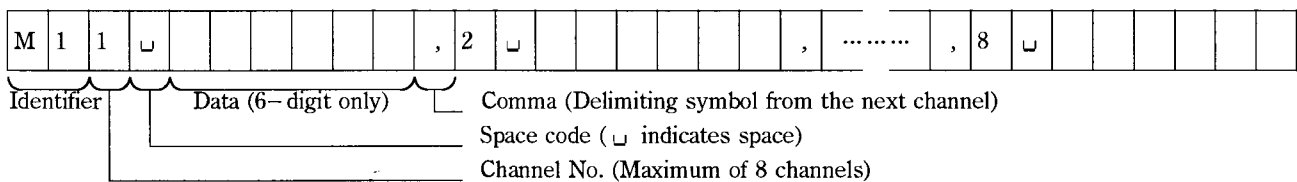

Identifier type

M1 (Temperature measured-value)	O1 (Heating control output status)	O2 (Cooling control output status)
M2 (Current transformer input value)	S1 (Temperature set-value)	D1 (Derivative time set-value)
T0 (Heating-side proportioning cycle)	I1 (Integral time set-value)	A3 (Heater break alarm set-value)
PB (PV bias)	T1 (Cooling-side proportioning cycle)	V1 (Deadband)
P1 (Heating-side proportional band set-value)	P2 (Cooling-side proportional band set-value)	

(2) Data without channel No.

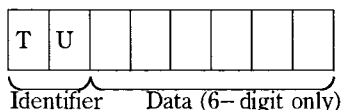

Identifier type : TU (Output monitoring time)

■ 7-Digit Data Length Type

[Identifier type : A1 (First alarm set-value, A2 (Second alarm set-value)]

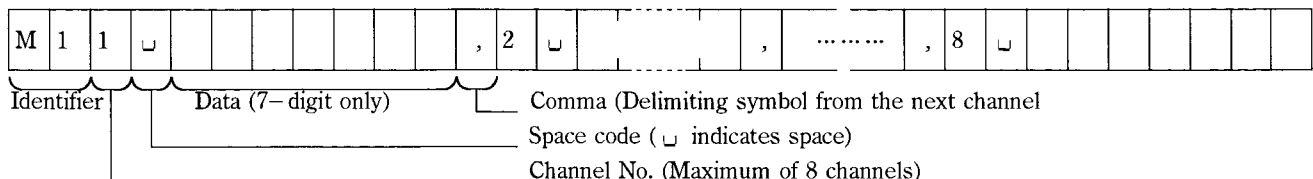

10. INITIALIZE SETTING

The initialize setting is for changing the input, control or alarm type specified when ordering.

Therefore, carefully change this type on your responsibility.

CAUTIONS

- Each setting is such that change are unnecessary under ordinary instrument operation. Note that frequent changes may result in instrument malfunction or failure. RKC bears no responsibility for any instrument failure or damage caused by such changes.
- Do not change each optional initialize setting items (marked with ★) since doing so may also requires hardware modification.

10.1 Initial setting items

#1 : Attribute

(RW : Readout / write)

No.	Name	Identifier	Dgt	#1	Data range	Description	Default value
1	Input range No.	XI	6	RW	TC : 0 to 78 RTD : 0 to 5	Sets the desired input type and range code. (See page 18)	According to input type
2	Setting limit (High-limit)	XV	6	RW	Setting limit low-limit to input range high-limit	Sets the setting limit high-limit.	According to input type
3	Setting limit (Low-limit)	XW	6	RW	Input range low-limit to setting limit high-limit	Sets the setting limit low-limit.	According to input type
4	ON/OFF action differential gap (Upper)	IV	6	RW	0.00 to 10.00% of span	Sets differential gap above ON/OFF action set-value.	0.10
5	ON/OFF action differential gap (Lower)	IW	6	RW	0.00 to 10.00% of span	Sets differential gap below ON/OFF action set-value.	0.10
6	First alarm differential gap	HA	6	RW	0.00 to 10.00% of span	Sets the first alarm differential gap.	0.10
7	Second alarm differential gap	HB	6	RW	0.00 to 10.00% of span	Sets the second alarm differential gap.	0.10
8	First alarm type	XA	1	RW	0 : Process high alarm 1 : Process low alarm 2 : Deviation high alarm 3 : Deviation low alarm	Selects alarm action type of first alarm.	2
9	Second alarm type	XB	1	RW	4 : Deviation high/low alarm 5 : Band alarm 6 : No alarm	Selects alarm action type of second alarm.	3
10	Presence/absence of first alarm with hold action	WA	1	RW	0 : Without hold action 1 : With hold action	Selects the presence/absence of first alarm hold action.	1
11	Presence/absence of second alarm with hold action	WB	1	RW		Selects the presence/absence of second alarm hold action.	1
12	First alarm interlock selection	LA	1	RW	0 : Without interlock 1 : With interlock	Selects the presence/absence of first alarm interlock.	0
13	Second alarm interlock selection	LB	1	RW		Selects the presence/absence of second alarm interlock.	0
14	First alarm selection at input abnormality	OA	1	RW	0 : Forced alarm ON when measured-value (PV) exceeds the input error determination point.	Selects the first alarm action when the measured-value (PV) exceeds the input error determination point.	0
15	Second alarm selection at input abnormality	OB	1	RW	1 : Normal alarm action	Selects second alarm action when the measured-value (PV) exceeds the input error determination point.	0
16	Digital filter	F1	6	RW	0 to 100 sec (0 sec : Digital filter OFF)	Decreases noise contained sensor input by using a first-order lag filter with the preset time constant.	0

(To be continued to the next page.)

No.	Name	Identifier	Dgt	#1	Data range	Description	Default value
17	Resolution	XU	1	RW	0 : 1 °C 1 : 0.1 °C	Selects the input range resolution.	1
18	Alarm timer setting time	TD	1	RW	0 to 9 second (0 sec : Alarm timer OFF)	Sets the alarm timer time. The alarm is turned ON if the measured value remains in the alarm range succession for more than the time set here.	0
19	Selection of operation at power-ON	XH	1	RW	0 : Control start immediately at power-ON 1 : Control stop until the start command is received from the host computer.	Selects the control start state at power-ON.	0
20	Communication delay time	IT	6	RW	0 to 1000 ms	Sets the interval time to attain the adequate timing of data send and receive in communication.	0
21	Heater break alarm selection ★	XX	1	RW	0 : Without HBA 1 : CTL-6P-N 2 : CTL-12-S56-10L-N	Selects the CT type used for heater break alarm.	0
22	Number of heater break alarm trigger times. ★	TG	6	RW	1 to 99 times	Sets the number of heater break alarm (HBA) trigger times. The HBA is produced if the HBA state continues in succession exceeding the number of times set here.	2
23	Alarm energized/De-energized selection ★	NA	1	RW	0 : Energized 1 : De-energized	Selects the energized alarm/de-energized alarm type of the alarm output relay.	0
24	Auto tuning differential gap	GH	6	RW	0 to 3600 second	Sets the auto tuning differential gap.	10
25	Auto tuning dead time	GT	6	RW	0 to 10 second	Sets the dead time for the AT function.	2
26	Control type	XE	1	RW	0 : Heating control 1 : Heating/cooling control	Selects the control type.	0
27	Cooling method type	XQ	1	RW	0 : Air cooling 1 : Water cooling	Selects the cooling method at heating/cooling control.	0
28	Shortest cooling output ON time	OQ	6	RW	0.0 to 1.0 second 0.0 second : Fixed period time proportioning output	Sets the shortest cooling output ON time. The output period can be varied by setting the shortest cooling output ON time at the low load factor at which the cooling output ON time is extremely short.	0.0

<Initialize setting procedure>**Mode transfer by switch**

- ① Turn OFF the power.
- ② Transfer to initialize setting mode.
Turn ON the No. 8 data type setting switch (SW103).
- ③ Turn ON the power again.
- ④ Change the setting for initialize setting items.
- ⑤ Transfer to normal mode.
Turn OFF the No. 8 data type setting switch (SW103).
- ⑥ Turn the power OFF, then back on again.
- ⑦ Initialize setting are established.

Mode transfer via communication

The REX-B850 can enter initialize setting mode by the following identifier.

Identifier	Digits	Data range
J M Y A	1	0 : Initial mode OFF 1 : Initial mode ON

*No data type setting switch (SW103) selection operation is performed during "Mode transfer via communication."

Input range No. table

(TC input)

Input type	Range	Range No.
K	0 to 200 °C	0
	0 to 400 °C	1
	0 to 800 °C	2
	0 to 1300 °C	3
	-50 to +150 °C	4
	-200 to +200 °C	5
	-200 to +300 °C	6
	-200 to +600 °C	7
	-200 to +1300 °C	8
	0 to 800 °F	9
0 to 2400 °F	10	
J	0 to 200 °C	11
	0 to 400 °C	12
	0 to 600 °C	13
	0 to 800 °C	14
	0 to 1200 °C	15
	-50 to +150 °C	16
	-200 to +200 °C	17
	-200 to +300 °C	18
	-200 to +400 °C	19
	-200 to +600 °C	20
	-200 to +1200 °C	21
	0 to 700 °F	22
	0 to 1600 °F	23
	0 to 2100 °F	24
R	0 to 1700 °C	25
	0 to 3000 °F	26
S	0 to 1700 °C	27
	0 to 3000 °F	28
B	0 to 1400 °C	29
	0 to 1800 °C	30
	0 to 2500 °F	31
	0 to 3000 °F	32
E	0 to 200 °C	33
	0 to 400 °C	34
	0 to 700 °C	35
	0 to 1000 °C	36
	-50 to +150 °C	37
	-200 to +200 °C	38
	-200 to +300 °C	39
	-200 to +400 °C	40
	-200 to +1000 °C	41
	0 to 1800 °F	42
T	0 to 200 °C	43
	0 to 400 °C	44
	-50 to +150 °C	45
	-200 to +200 °C	46
	-200 to +300 °C	47
	-200 to +400 °C	48
	0 to 700 °F	49
	-200 to +400 °F	50

Input type	Range	Range No.
T	-300 to +400 °F	51
	-300 to +700 °F	52
N	0 to 1300 °C	53
	0 to 1300 °F	54
PL II	0 to 1300 °C	55
	0 to 2300 °F	56
W5Re/ W26Re	0 to 1200 °C	57
	0 to 2300 °C	58
	0 to 2200 °F	59
	0 to 3000 °F	60
U	0 to 200 °C	61
	0 to 400 °C	62
	0 to 600 °C	63
	-200 to +200 °C	64
	-200 to +300 °C	65
	-200 to +400 °C	66
	-200 to +600 °C	67
	0 to 1100 °F	68
	-300 to +400 °F	69
	L	0 to 200 °C
0 to 400 °C		71
0 to 600 °C		72
0 to 900 °C		73
-200 to +200 °C		74
-200 to +300 °C		75
-200 to +400 °C		76
-200 to +600 °C		77
-200 to +900 °C		78
0 to 1600 °F		79
-300 to +400 °F		80

(RTD input)

Input type	Range	Range No.
JPt100	-100 to +100 °C	0
	-200 to +500 °C	1
	-150 to +200 °F	2
	-200 to +900 °F	3
Pt100	-100 to +110 °C	4
	-200 to +600 °C	5
	-150 to +200 °F	6
	-200 to +1000 °F	7

10.2 Initialize Setting Data Configuration

The structure of initialize setting data is the same as that of the ordinary communication data. The configuration of data is shown below. A block excluding the [STX], [ETX] and [BCC] transmission control characters corresponds to the data block.

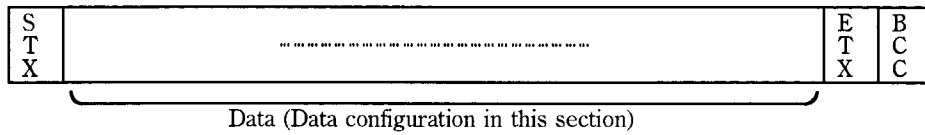

* For details on communication procedure, See "**COMMUNICATION PROTOCOL**" (P. 10).

■ 1-Digit Data Length type

(1) Data with channel No.

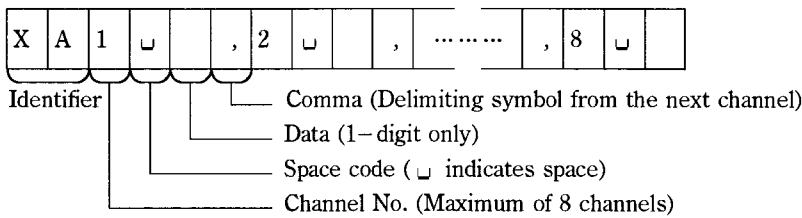

Identifier type

XA (First alarm type)	XB (Second alarm type)	WA (Presence/absence of first alarm with hold action)
WB (Presence/absence of second alarm with hold action)	LA (Presence/absence of first alarm interlock)	LB (Presence/absence of second alarm interlock)
OA (First alarm selection at input abnormality)	OB (Second alarm selection at input abnormality)	XU (Resolution)

(2) Data without channel No.

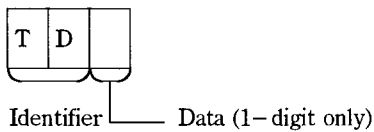

Identifier type

TD (Alarm timer setting time)	XH (Start mode selection)
XX (Presence/absence of HBA)	NA (Alarm energized/de-energized selection)
XE (Control type)	XQ (Cooling method type)

■ 6-Digit Data Length type

(1) Data with channel No.

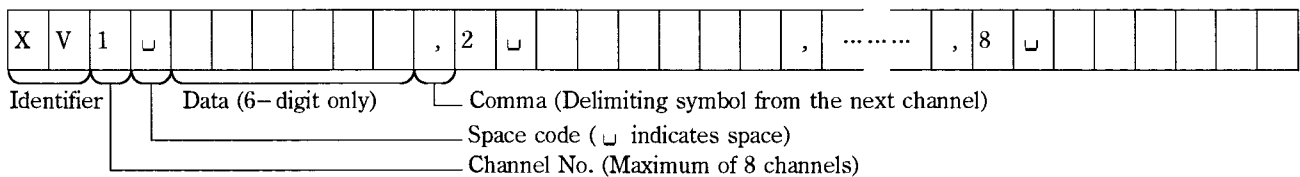

Identifier type

XV (Setting limit high-limit)	XW (Setting limit low-limit)	IV (ON/OFF action differential gap)
IW (ON/OFF action differential gap)	HA (First alarm differential gap)	HB (Second alarm differential gap)
F1 (Digital filter)	OQ (Shortest cooling output ON time)	_____

(2) Data without channel No.

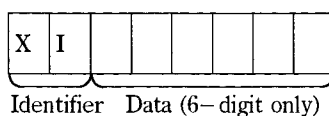

Identifier type

XI (Input range No.)	IT (Communication delay time)
TG (Number of HBA trigger times)	GH (AT differential gap)
GT (AT dead time)	_____

11. SPECIFICATIONS

Interface Specification

Interface

Based on RS-422A, EIA standard
 Based on RS-485, EIA standard
 Based on RS-232C, EIA standard

Connection method

4 wire-system, multi-drop connection (RS-422A)
 2 wire-system, multi-drop connection (RS-485)
 Point to point connection (RS-232C)

Synchronous method Start/stop synchronous type

Communication speed

19200bps, 9600bps, 4800bps, 2400bps

Bit configuration

Start bit : 1
 Data bit : 7 or 8
 Parity bit : None or 1 (Odd number or even number)
 Stop bit : 1 or 2

Protocol

ANSI X3.28 subcategory 2.5, A4
 Polling/selection type

Error control Horizontal parity

Block length Within 128 bytes

Maximum connection

RS-422A : 16 points
 RS-485 : 16 points
 RS-232C : 1 point

Communication code JIS/ASCII (7 bit code)

Time-out time About 3 second

Terminal Voltage and Signal Logics

RS-422A, RS-485

	Mark status (Stop bit and signal 1)	Space status (Start bit and signal 0)
Send data T (A), T (B)	Voltage between $T (A) - T (B) \leq -2V$	Voltage between $T (A) - T (B) \leq -2V$
Receive data R (A), R (B)	Voltage between $R (A) - R (B) \leq -2V$	Voltage between $R (A) - R (B) \leq -2V$

RS-232C

Signal voltage	Signal logic
+3 V or more	0 (Space status)
-3 V or less	1 (Mark status)

Specifications

Input

Input type TC input : K, J, R, S, B, E, T, N,
 PL II, U, L, W5Re/W26Re
 RTD input : Pt100, JPt100
 *Common to all channels

Input impedance More than 1 M Ω (TC input)

Allowable input lead Less than 10 Ω (RTD input)

Sampling cycle 1 second

Measured accuracy $\pm (0.3\% \text{ of span} \pm 1 \text{ digit})$
 *TC B input ; 0 to 400 $^{\circ}\text{C}$
 : Not guaranteed

Input filter

The first order lag digital filter
 Time constant : 0 to 100 second
 (0 second : Digital filter OFF)

PV bias -5.00 to +5.00 % of span

Action at input break Upscale*

Action at input shorting Downscale (RTD)*

*Control action

Heating control :
 Direct action---Control output OFF of channel whose input is broken or shorted
 Reverse action---Control output ON of channel whose input is broken or shorted
Heating/cooling control : Heating/cooling control output OFF
Alarm action : Alarm output ON or normal alarm action
 (Can be selected for each channel)

Setting

	Setting range
Setting value	Same as input range
Heating side proportional band	0.1 to 1000.0% of span 0.0% setting : ON/OFF control (Valid at heating control)
Cooling side proportional band	0.1 to 1000.0% of span
Integral time	1 to 3600 second *0 sec. setting : Proportional control
Derivative time	1 to 3600 second *0 sec. setting : PI control
Time proportioning cycle (heating-side)	1 to 100 second
Time proportioning cycle (cooling-side)	1 to 100 second
Differential gap	0.00 to 10.00% of span *Setting item in ON/OFF control
Multi-memory area function	8-memory area *Set data up to 8 channels can be stored in one memory area.
Setting accuracy	Setting value : $\pm (0.3\% \text{ of span} \pm 1 \text{ digit})$ Besides setting value : Within $\pm 0.5\%$ of setting range

Control action

Control method

- Brilliant PID control
 *Control response parameter : Slow, Medium, Fast
 (3-step selection)
- *Derivative time 0 sec. : PI control
- Proportional control
 (Can be selected at only heating control)
- ON/OFF control
 (Can be selected at only heating control)

Other function

- With overshoot function (RFB limit method)
- With enhanced auto-tuning function
- Output monitoring function (With 0 min. set : OFF)

Control output (Open correcter output)

Output points Maximum 8 points
Output method Transistor sink output
Load voltage 10.8 to 26.4 V DC (Rated 12 to 24 V DC)
Maximum load current 100 mA
Leakage current at OFF 0.1 mA or less
Maximum voltage drop at ON 2.4 V or less
(At a load current of 100 mA)

Event input

Input points 1 point
Input method Voltage contact
Rated input voltage 24 V DC
(21.6 to 26.4 V DC)
Rated input current 2.3 mA (24 V DC)
Input impedance 10 k Ω
Function · Unused
· Control stop command
· Event input monitor
· Memory area change command
(However, change control area and No.8 are
a) · Auto-tuning start command
· Control run/stop command
· Alarm interlock release command
*Specify when ordering

Alarm

Alarm points 2 points
Alarm type Process high alarm Process low alarm
Deviation high alarm Deviation low alarm
Deviation high and low alarm Band alarm
*Can be selected for each alarm
Setting range Process high alarm : Same as input range
Process low alarm : Same as input range
Deviation high alarm : - span to +span
Deviation low alarm : - span to +span
Deviation high and low alarm : 0 to span
Band alarm : 0 to span
Setting accuracy \pm (0.3% of span \pm 1 digit)
Differential gap 0.00 to 10.00 % of span
Hold action Can select the presence or absence of hold
action for each alarm.
Alarm timer setting 0 to 9 second
*Common to each alarm,
each channel
Spectral action at input error
For "PV \geq Input error trigger point (High limit) or
"PV \leq Input error trigger point (Low limit) :
Alarm output ON

Input error trigger point range High limit : 105 % only
Low limit : -5.0 % only

Alarm output*

Output points 2 points
Output method Transistor sink output
Load voltage 10.8 to 26.4 V DC (Rated 12 to 24 V DC)
Maximum load current 100 mA
Leakage current at OFF 0.1 mA or less
Maximum voltage drop at ON 2.4 V or less
(At a load current of 100 mA)

*Output common to each channel
In addition, OR output of each channel for each alarm
function.

Power failure measures

Memory backup Stored data backup by lithium battery
Battery life Approx. 10 years
(Total time when power is turned OFF)
*However, the above life differs depending on
the product storage period, and storage and
operating environments.
Power failure effect No influence is exerted upon the
controller for power failure of less
than 50 ms.

Self-diagnostic function

Check item · RAM check
· Adjustment data check
· Input value check
· Watch-dog timer

Action in trouble Control output, alarm output : OFF

FAIL output*

Output points 1 points
Output method Transistor sink output
Load voltage 10.8 to 26.4 V DC (Rated 12 to 24 V DC)
Maximum load current 100 mA
Leakage current at OFF 0.1 mA or less
Maximum voltage drop at ON 2.4 V or less
(At a load current of 100 mA)

*FAIL output : OFF at error occurrence

Additional function

Temperature control function selection

· Reverse action
· Direct action (Valid at heating-side control)
· Monitor (Alarm output ON, control output OFF)
· Unused (Alarm output OFF, control output OFF)
*Can be selected for each channel

Start mode selection

· Control action start at power-ON.
· Control action stop until start command issued from
host computer
*Specify when ordering

Heater break alarm function (Option)

Input points Maximum 8 points

Input type

Current transformer output
Recommend type (Specify when ordering)
CTL-6-P-N : 0 to 30 A
CTL-12-S56-10L-N : 0 to 100 A

Setting range 0.0 to 100.0 A

Setting accuracy 5 % of input-value or 2.0 A
(Within the value whichever is the greater)

Output 0 to 2 (Via communication data)

Accuracy

Insulation resistance

Between measuring and grounding terminals :
20 M Ω or more at 500 V DC
Between power and grounding terminals :
20 M Ω or more at 500 V DC

Withstand voltage

100 to 240 V AC
Between measuring and grounding terminals :
For 1 min. at 1000 V AC
Between power and grounding terminals :
For 1 min. at 1500 V AC
24 V AC/24 V DC
Between measuring and grounding terminals :
For 1 min. at 500 V AC
Between power and grounding terminals :
For 1 min. at 750 V AC

Use & storage ambient condition

Use : Ambient temperature 0 to 50 °C

Ambient humidity 40 to 85 % RH
(No condensation)

Operating environment There should be neither
corrosive gases nor much
dust.

Storage : Storage ambient temperature -20 to +50 °C

Storage ambient humidity 95 % RH or less

Power supply voltage

Power supply voltage

90 to 264 V AC (50/60 Hz common use)
[Including power supply voltage variation]
(Rated 100 to 240 V AC)
21.6 to 26.4 V DC
[Ripple factor : Less than 10%_{P-P}]
(Rated 24 V DC)
21.6 to 26.4 V AC
[Ripple factor : Less than 10%_{P-P}]
(Rated 24 V AC)
*Specify when ordering

Power consumption

90 to 264 V AC : 9 VA or less
21.6 to 26.4 V DC : 150 mA or less
21.6 to 26.4 V AC : 6 VA or less

Others

Weight Approx. 350 g

12. DESCRIPTION OF MAIN FUNCTION

Input

(1) First order lag digital filter

This is a software filter which reduces input value variations caused by noise. If the time constant of this filter is set appropriately to match the characteristics of the controlled object and the noise level, the effects of input noise can be suppressed. However, if the time constant is too small, the filter may not be effective, while if the time constant is too large, then the input response may actually deteriorate.

(2) PV bias

The value set in the PV bias is added to the actual input value to correct the input value. The PV bias is used to correct the individual variations in the sensors or when there is difference between the measured-values (PV) of other instruments.

$$\text{Displayed value} = \text{Measured-value} + \text{PV bias}$$

[Example] For a span of 400 °C, PV bias correction value of +2 °C is added

$$\text{PV bias} = 0.5\% \\ (400 \times 0.5\% = 2 \text{ } ^\circ\text{C})$$

Setting

(1) Multi-memory area function

This function is to store the parameters such as temperature set-value (SV), etc. in up to 8 memories. The parameters stored in one of 8 memories retrieved at necessity and used for control. The memory area used for this control is called the control area.

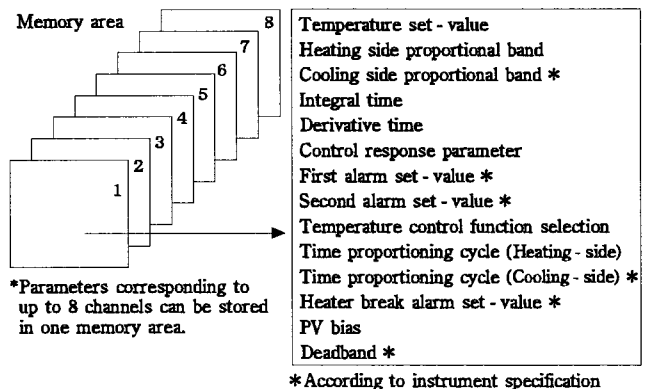

(2) Setting limit function

The setting limit is used to restrict the setting range of the temperature set-value.

[Example] For a setting range of 0 to 40 °C, a setting limit (high-limit) of 200 °C and a setting limit (low-limit) of 20 °C.

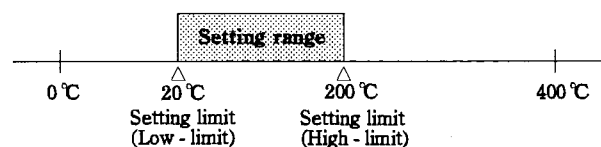

Control

(1) Brilliant PID control

PID control is a control method of achieving stabilized control result by setting P (Proportional band), I (Integral time) and D (Derivative time) constants.

However even in this PID control if P, I and D constants are set so as to be in good "response to setting", "response to disturbances" deteriorates. In contrast, if PID constants are set so as to be in good "response to disturbances", "response to setting" deteriorates. In brilliant PID control a form of "response to setting" can be selected from among *Fast*, *Medium* and *Slow* with PID constants remaining unchanged so as to be in good "response to disturbances".

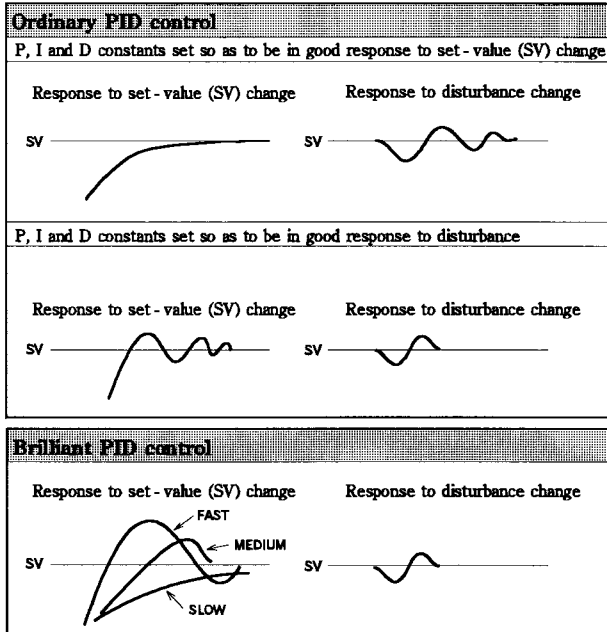

(2) Control response parameter

The control response parameter function is used to determine how to response to temperature set-value (SV) changes in PID control. One control response parameter can be selected from among three steps (FAST, MEDIUM, SLOW).

However, there are no significant changes in the setting time among these 3 steps.

FAST	Selected when the rise time needs to be shortened (operation needs to be quickly started). Slight overshooting cannot be avoided.
MEDIUM	Middle of "FAST" and "SLOW". Overshooting become smaller than for "FAST".
SLOW	Selected when overshooting must be avoided. Used when the material may be deteriorated if the temperature exceeds the set value.

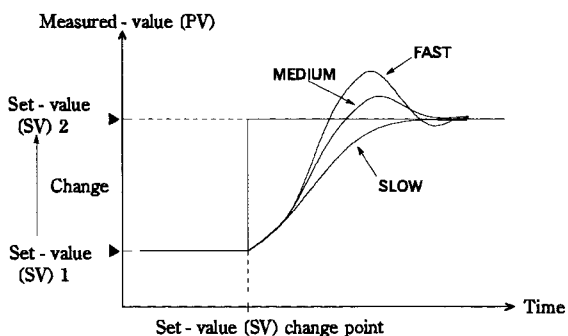

(3) ON/OFF control

In ON/OFF control, the manipulated output is turned ON and OFF depending on whether measured-value (PV) is larger or smaller than set-value (SV). Differential gap setting can prevent relay contact from ON or OFF repetition around set-value (SV).

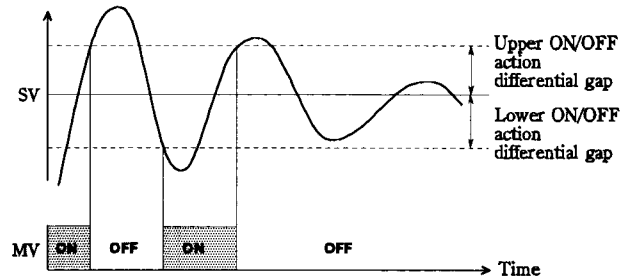

(4) Heating/cooling control

In heating/cooling control, only one controller enables heating and cooling control. For example, this is effective when cooling control is required in extruder cylinder temperature control.

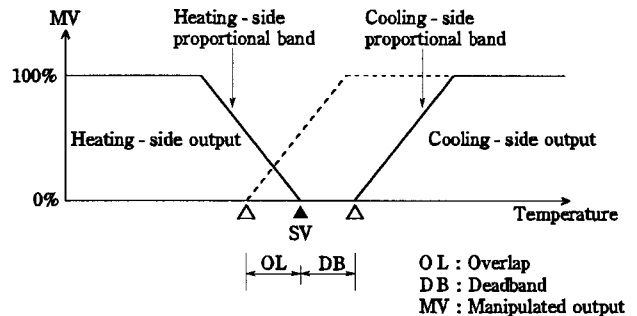

(5) Auto-tuning

This function automatically measures, computes and then sets the optimum PID constants. This function can be executed from any state power-ON, during temperature rise or during stabilized control.

<When the auto-tuning start after power-ON>

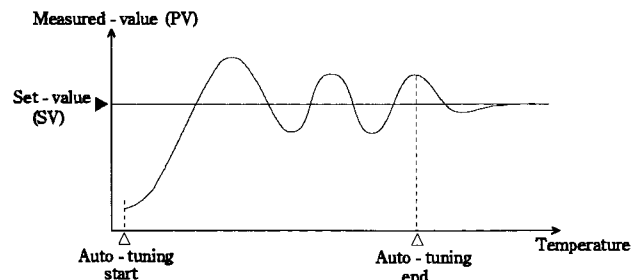

(6) Direct/reverse action

● Direct action :

The manipulated output value (MV) increases as the measured-value (PV) increases. This action is used generally for cooling control.

● Reverse action :

The manipulated output value (MV) increases as the measured-value (PV) increases. This action is used generally for cooling control.

(7) Overshooting prevention function (RFB limit)

When the deviation continues for a long time, the PID computation result exceeds the effective manipulated variable range (0 to 100%). In this case, the PID computation result does not return immediately within the effective output range due to the integral action even if the deviation becomes smaller. For this reason, execution of the actual corrective actions is delayed. The RFB (RESET-FEEDBACK) is activated so that if the PID computation result exceeds the limit point (100%), the amount exceeding the limit point is fed back to the integral value to hold the computation result to the limit point, and thus the result is kept within the effective range. This means that if the deviation becomes smaller, the corrective action is immediately taken.

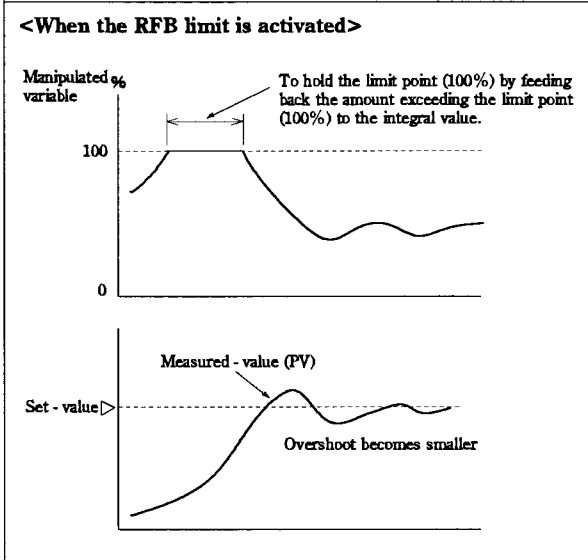

(8) Output monitoring function

This function is used to monitor the time during which a manipulated variable of 100% is output in succession. If an output of 100% continues for more than the output monitoring set time, this is judged as FAIL so that the manipulated variable is not output.

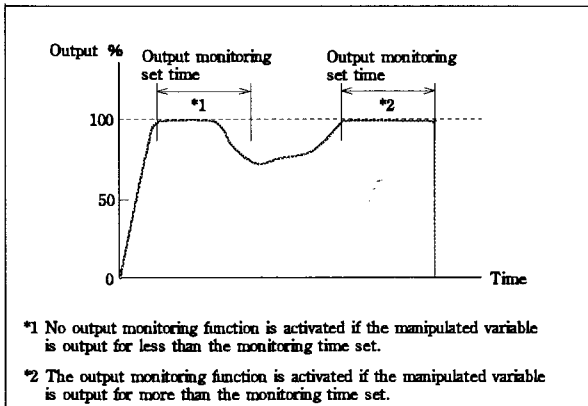

■ Temperature Alarm (Process/Deviation Alarm)

Alarm function sets up the alarm status when the measured-value (PV) or the deviation reaches the alarm set-values. The alarms are used to drive the equipment danger signals or the safety equipment.

(1) Process alarm

When the measured-value (PV) reaches the alarm set-value, the alarm status is set up.

● Process high alarm

When the measured-value (PV) is greater than the alarm set-value, the alarm status is set up.

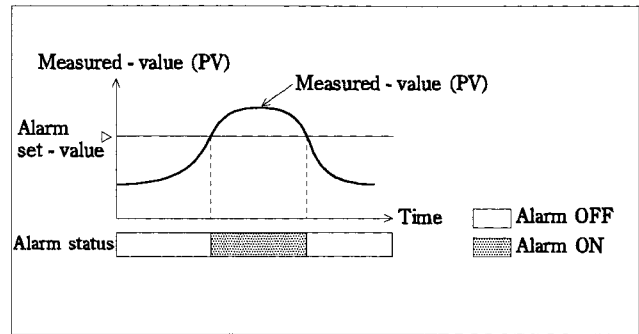

● Process low alarm

When the measured-value (PV) is less than the alarm set-value, the alarm status is set up.

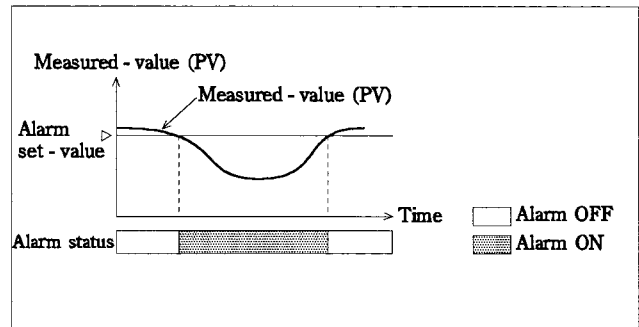

(2) Deviation alarm

If the deviation [Measured-value (PV) - Set-value (SV)] reaches the alarm set-value, the alarm status is set up. Consequently, if the set-value (SV) changes, the alarm set-value will also change.

● Deviation high alarm

When the deviation [Measured-value (PV) - Set-value (SV)] is greater than the alarm set-value, the alarm status is set up.

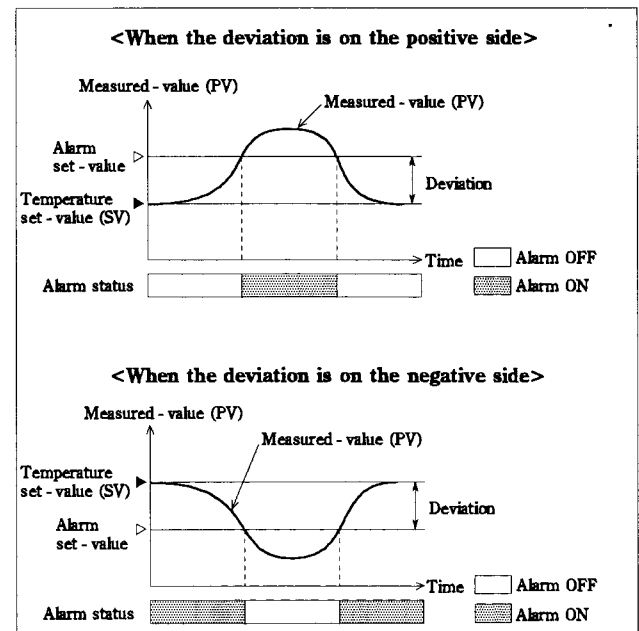

● Deviation low alarm

When the deviation [Measured-value (PV) - Set-value (SV)] is less than the alarm set-value, the alarm status is set up.

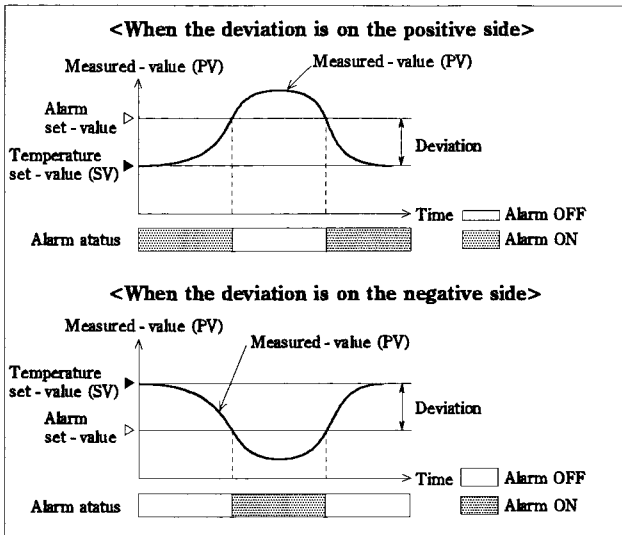

● Process low alarm, deviation low alarm

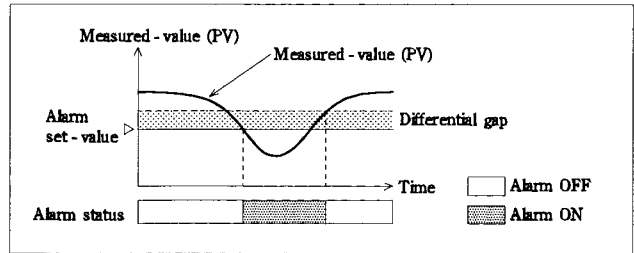

● Deviation high and low alarm

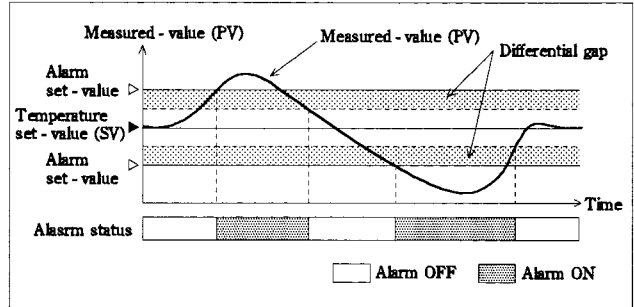

● Deviation high and low alarm

When the absolute deviation $| \text{Measured-value (PV)} - \text{Set-value (SV)} |$ is greater than the alarm set-value, the alarm status is set up.

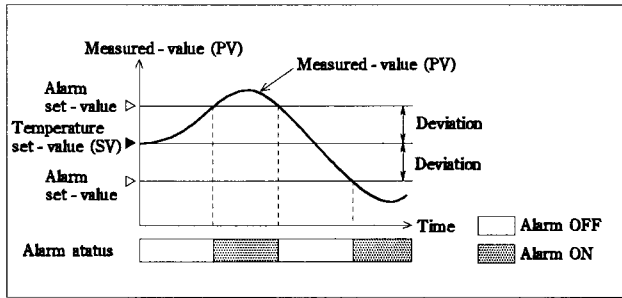

● Band alarm

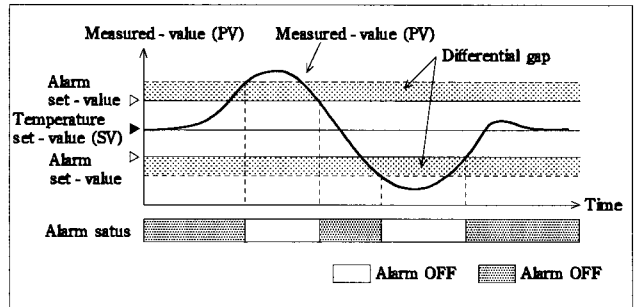

● Band alarm

When the absolute deviation $| \text{Measured-value (PV)} - \text{Set-value (SV)} |$ is within the alarm set-values, the alarm status is set up.

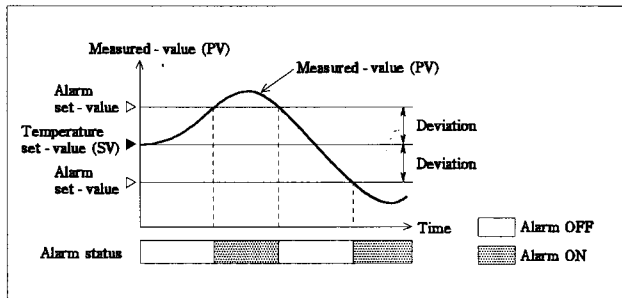

(4) Alarm hold function

In the alarm hold function, the alarm function is kept invalid even if the measured-value (PV) is in the alarm range when the power is on or the set-value is changed. The alarm function is held until the measured-value (PV) goes out of the alarm state once.

[Example] Difference of "With hold action" and "Without hold action" at deviation low alarm.

<With alarm hold action>

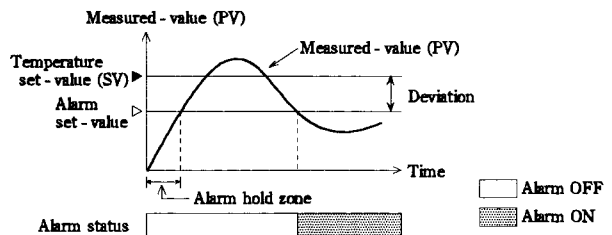

<Without alarm hold action>

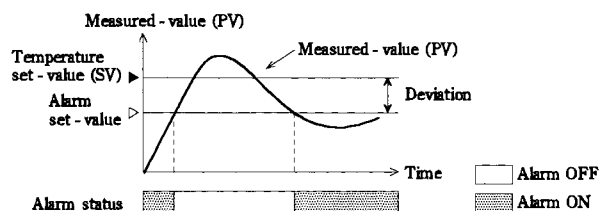

(3) Alarm differential gap

If measured-value (PV) is close to the alarm set-value, the alarm relay contact may repeatedly turn ON and OFF due to input fluctuations. If the differential gap is set, repeated turning ON and OFF of the relay contact can be prevented.

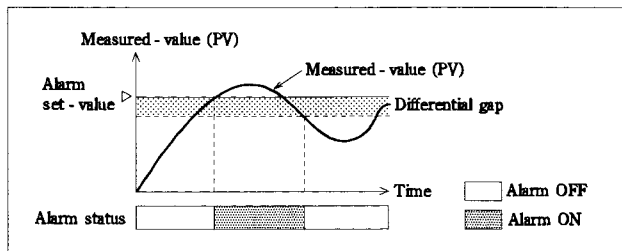

(6) Alarm timer function

The alarm timer is used to set the input to the nonalarm state until the time set by the alarm timer elapses even if the input reaches the alarm set-value after the measured value (PV) or deviation reaches the alarm set-value, and to set the input to the alarm state after the time set by the alarm timer elapses.

[Example] If the alarm timer is set to 5 second.

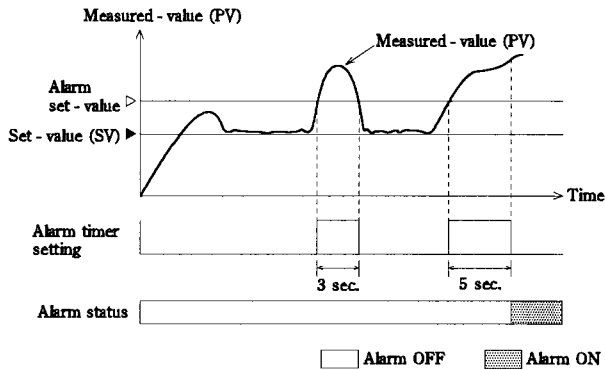

(7) Alarm energized/de-energized

When relay contact output is used for alarm output, both energized and de-energized alarms are available.

- **Energized** : Relay contact is closed under the alarm status.
- **De-energized** : Relay contact opens under the alarm status.

Diagram of relay contact action (At power ON)

	Non - alarm status	Alarm status
Energized		
De - energized		

(8) Alarm interlock function

The alarm interlock function is used to hold the alarm state even if the measured-value (PV) is out of the alarm zone after its entry into the zone once.

[Example] If the alarm type is process low alarm.

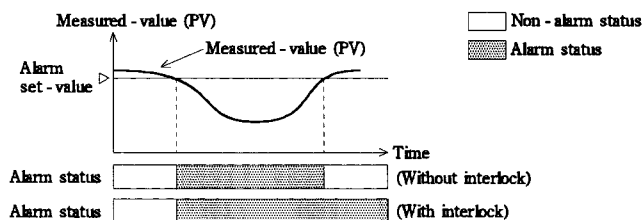

Heater Break Alarm (HBA) Function [Option]

The heater break alarm (HBA) function is used to detect current flowing through the load by the current transformer (CT) and to set the current to the alarm state if the input to the current transformer is more or less than the heater break alarm (HBA) setting value by comparing the detected value (input to the current transformer) with the heater break alarm (HBA) set-value.

[Connecting example]

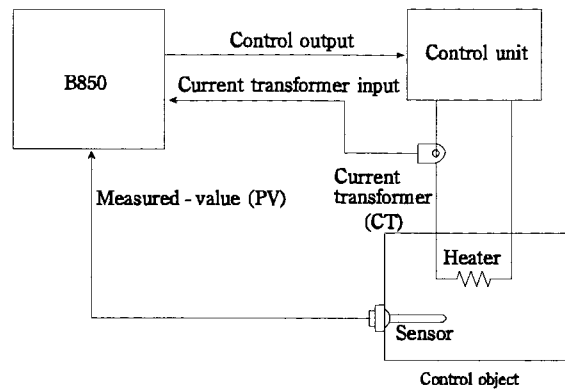

(1) Alarm action

The HBA function is activated for the following cases.

- **When no heater current flows** ... Heater break, faulty operation, etc.

The alarm state is set when the current transformer input is less than the heater break alarm current set-value at control output ON. However, no heater break alarm function is activated if the control output ON time is less than 0.5 sec.

- **When no heater current turn off** ... Weld relay contact, etc.

The alarm rate is set when the current transformer input is more than the heater break alarm current set-value at control output OFF. However, no heater break alarm function is activated if the control output OFF time is less than 0.5 sec.

NOTE

- The heater current display is updated by using the captured value in the control output ON state. However, it is updated by using the captured value in the control output OFF state if the relay contacts are melted.

(2) Setting of the number of alarm triggering times

This function is used to set the output to the non-alarm state when the HBA state is within the number of preset times, and to set the output to the alarm state when the HBA state is continuously more than the number of preset times.

[Example] When the number of CT input is 1 per channel and the number of alarm triggering in CH1 is set to 4.

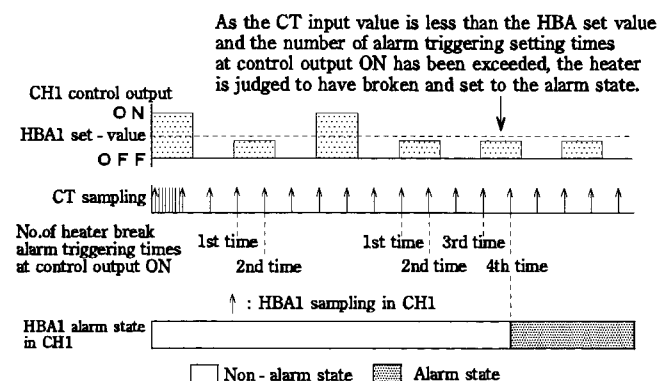

NOTE

- The CT sampling period varies with the capture time of control output ON or OFF and the number of CT input times.

■ Function Activated at Input Error

The function activated at input error is used to inform the operator of an input error when the measured-value (PV) input signal wire is disconnected or the measured-value (PV) reaches the input error determination point.

(1) When the measured-value (PV) signal wire is disconnected (shorted)

When disconnected :

The upscale function is activated to raise the measured value (PV). (TC input or RTD input)

When shorted :

The downscale function is activated to lower the measured value (PV). (RTD input only)

(2) When measured-value (PV) reaches input error determination point

● Output

Upscale

Control action :

For reverse action ... Control output OFF of corresponding channel

For direct action ... Control output ON of corresponding channel

Downscale (RTD only)

Control action :

For reverse action ...Control output OFF of corresponding channel

For direct action ...Control output ON of corresponding channel

● Alarm

Alarm action : Alarm output ON
Normal alarm action

*Can be selected for each alarm.

[Example] The following diagram shows an example of the process low grow input alarm.

Diagram of "Function activated at input error"

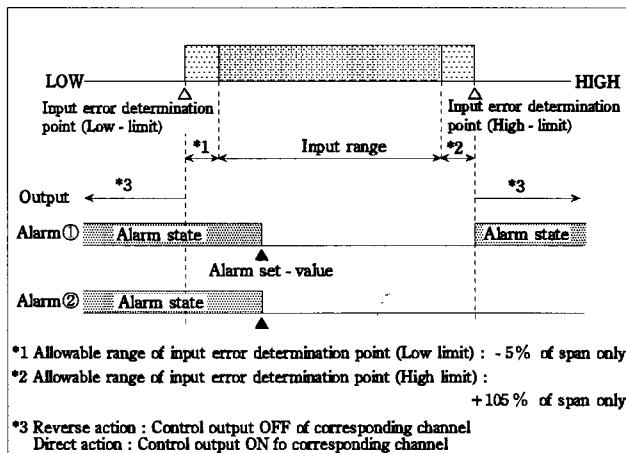

Alarm ① (Alarm output ON) :

The alarm state is set when the measured-value (PV) exceeds not only the alarm set-value but also the high or low limit of the input error determination point.

Alarm ② (Ordinary alarm action) :

The alarm state is set when the measured-value (PV) exceeds the alarm set-value. No alarm state is set in the area where no alarm is set even when the measured-value exceeds the input error determination point.

■ Self-Diagnostic Function

The self-diagnostic function is used to conduct the following checks at power ON, during operation start or during operation. If any error is detected, the FAIL lamp lights and both control and alarm outputs are turned off. The content of the error (error code) can be checked via communication.

- RAM check
- Input value check
- Adjustment data check
- Watch-dog timer

13. TROUBLESHOOTING

The unit trouble, causes and measures considered to be general are described in the following tables. For any trouble occurring due to causes other than the following, contact our agent where you purchased the unit or directly us after confirming the Model No. and specifications.

When taking the necessary measures according to the troubleshooting procedure, strictly observe the following warning.

⚠ WARNING

- In order to prevent electric shock or instrument failure, always turn OFF the power before mounting or removing the instrument.
- In order to prevent electric shock or instrument failure, do not turn ON the power before all the wiring is finished.
- In order to prevent electric shock or instrument failure, do not touch the inside of the print wiring board or connector pins.
- Wiring is necessary to be performed by personnel who have a fundamental knowledge of electricity and also have experience in wiring.

Trouble	Cause	Measures
The power LED does not light	The proper power supply voltage is not being supplied	Supply the normal power.
	Imperfect power connector contact	Tighten the terminals.
	The power is not supplied	Check the external breaker.
Measured-value (PV) display differs from the actual value	A PV bias set	Set the PV bias to "0". However, this is limited only to when the PV bias setting can be changed.
Control is abnormal	Break of sensor and input lead wires	Repair the sensor or replace it.
	Proper sensor is not used	Use the specified sensor.
	Sensor wiring improperly conducted	Check the wiring.
	Sensor insertion position is not appropriate	Insert the sensor at specified location.
	Input signal wires are not separated from instrument power and /or load wires	Separate each wire.
	Noise source is present near the wiring	Separate the noise source from the wiring.
	Inappropriate PID constants	Set each control constant to suit the controlled object.
	The minus (or plus) output lines on both heating and cooling sides are connected in common, then connected to the actuator in heating/cooling PID control.	Separate each output.
No optimum PID constants are set even if the AT function is activated	The AT function does not appropriately much the characteristics of the controlled-object.	Change the control response parameter type. Manually set the PID constants.
	SV does not become more than (or less than) a specific value	The setting limit is set Change the setting limit setting. However, this is limited only to the case where output limit setting may be changed.

(To be continue to next page)

Trouble	Cause	Measures
Alarm action is abnormal	Alarm action is different from the specification	Change the action after the specification is confirmed.
	Alarm output relay contact energized/de-energized is reversed	Change setting of energized/de-energized.
	Alarm differential gap setting is inappropriate	Set the appropriate differential gap.
	The alarm timer is set	Change the timer setting This is limited only to the case where the alarm timer setting may be changed.
No heater break can be detected	Heater break alarm setting is inappropriate (Option)	Set the appropriate heater break alarm set-value.
No-response	Trouble occurring in the controller	Contact our agent.
	Communication cable/connector failure or imperfect contact	Check the communication cable/connector.
	Incorrect communication method and communication speed.	Change the setting to match the host computer.
	Device address designation differs	Check the device address and then designate the device address again.
	Incorrect identifier	Identifier check and re-setting.
	Transmission line is not set to high impedance after data send [Specification conforming RS-485]	Program check on the host computer side.
[EOT] is returned when the polling procedure is executed	There is no specified identifier	Check the identifier and then set the identifier again.
	The identifier of function not added to the unit is specified	
[NAK] is returned when the polling procedure is executed	There is no specified identifier	Check the identifier and then set the identifier again.
	The identifier of function not added to the unit is specified	
	BCC error	Check the data and then set the data again.
	Data exceeds the setting range	
Backup data error [Error code 1]	Breakdown of the ROM	Contact our agent.
RAM read/write error [Error code 2]	Breakdown of the RAM	
A/D converter error [Error code 3]	Breakdown of the A/D converter	

Trouble	Cause	Measures
Adjustment data error [Error code 4]	Breakdown of the ROM, etc.	Contact our agent.
System data error [Error code 5]	Breakdown of the ROM, etc.	
Channel selection error [Error code 6]	Channel No. which does not exist was specified	Re-check the specification, then specify the correct channel No. again.
Output monitoring time over [Error code 7]	The control output exceeds 100 % in succession for 60 min.	Change the output monitoring time, only if required.

14. CODE TABLE

■ JIS/ASCII 7 Bit Code Table (For reference)

b 7	0	0	0	0	1	1	1	1				
b 6	0	0	1	1	0	0	1	1				
b 5	0	1	0	1	0	1	0	1				
b 5~b 7	b 4	b 3	b 2	b 1	0	1	2	3	4	5	6	7
	0	0	0	0	NUL	DLE	SP	0	@	P	~	p
	0	0	0	1	1	SOH	DC1	!	1	A	Q	a q
	0	0	1	0	2	STX	DC2	"	2	B	R	b r
	0	0	1	1	3	ETX	DC3	#	3	C	S	c s
	0	1	0	0	4	EOT	DC4	\$	4	D	T	d t
	0	1	0	1	5	ENQ	NAK	%	5	E	U	e u
	0	1	1	0	6	ACK	SYN	&	6	F	V	f v
	0	1	1	1	7	BEL	ETB	'	7	G	W	g w
	1	0	0	0	8	BS	CAN	(8	H	X	h x
	1	0	0	1	9	HT	EM)	9	I	Y	i y
	1	0	1	0	A	LF	SUB	*	:	J	Z	j z
	1	0	1	1	B	VT	ESC	+	:	K	[k {
	1	1	0	0	C	FF	FS	.	<	L	¥	l
	1	1	0	1	D	CR	GS	~	=	M]	m }
	1	1	1	0	E	SO	RS	.	>	N	^	n ~
	1	1	1	1	F	SI	US	/	?	O	_	o DEL

RKC RKC INSTRUMENT INC.

HEAD OFFICE: 16 - 6, KUGAHARA 5 - CHOME, OHTA - KU TOKYO 146 JAPAN

PHONE : 03 - 3751 - 9799 (+81 3 3751 9799)

Email : KGI00524@niftyserve.or.jp

FAX : 03 - 3751 - 8585 (+81 3 3751 8585)