

Pressure Indicator PG500 Operation Manual

All Rights Reserved. Copyright © 2007, RKC INSTRUMENT INC. **IMR02F02-E2**
Thank you for purchasing this RKC product. In order to achieve maximum performance and ensure proper operation of your new instrument, carefully read all the instructions in this manual. Please place this manual in a convenient location for easy reference.

This manual describes the operation method of the PG500. For the installation, the parts description, the specifications and the communication function (Optional), please read if necessary the following separate manuals.

- PG500 Installation Manual (IMR02F01-E0): Enclosed with PG500
- PG500 Communication Instruction Manual (IMR02F03-E0): Enclosed with PG500*
- * Only PG500 provided with the communication function

The above manuals can be downloaded from our website:
URL: http://www.rkcinst.com/english/manual_load.htm

1. HANDLING PROCEDURES

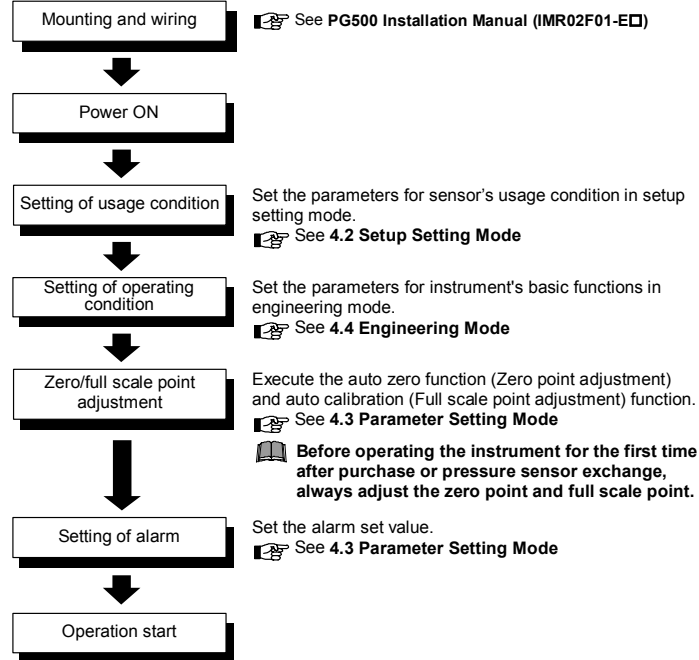

2. CHANGING DATA SETTINGS

- To store a new value for the parameter, always press the SET key.
- After a new value is displayed on the display by using UP and DOWN keys, if no key operation is performed for more than 1 minute without pressing SET key, this instrument returns to the Measured value (PV) screen and the set value will not be changed.

Example: Changing the alarm 1 set value (AL1) to 20 MPa

1. Select the alarm 1 set value (AL1) of parameter setting mode

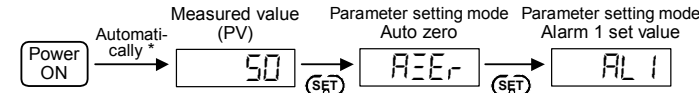

* After the pressure unit is displayed on the display (Approx. 4 seconds), the display will automatically change to the measured value (PV) screen.

2. Change the alarm 1 set value (AL1) to 20 MPa

Pressing the MONI key displays the data display. The high-lighted digit indicates which digit can be set.

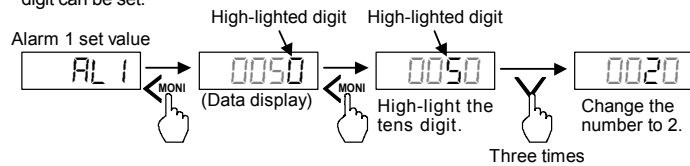

3. Store the alarm 1 set value (AL1)

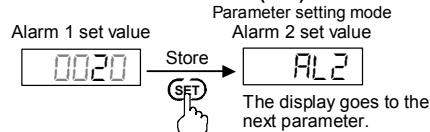

Other data can also be set by the same procedures as described in steps 1 to 3.

3. TRANSFER TO EACH MODE AND PARAMETER

- This instrument return to Measured value (PV) screen, if key operation for more than 1 minute is not performed.
- Any parameter which is not used in the instrument will not be displayed except for parameters in engineering mode.

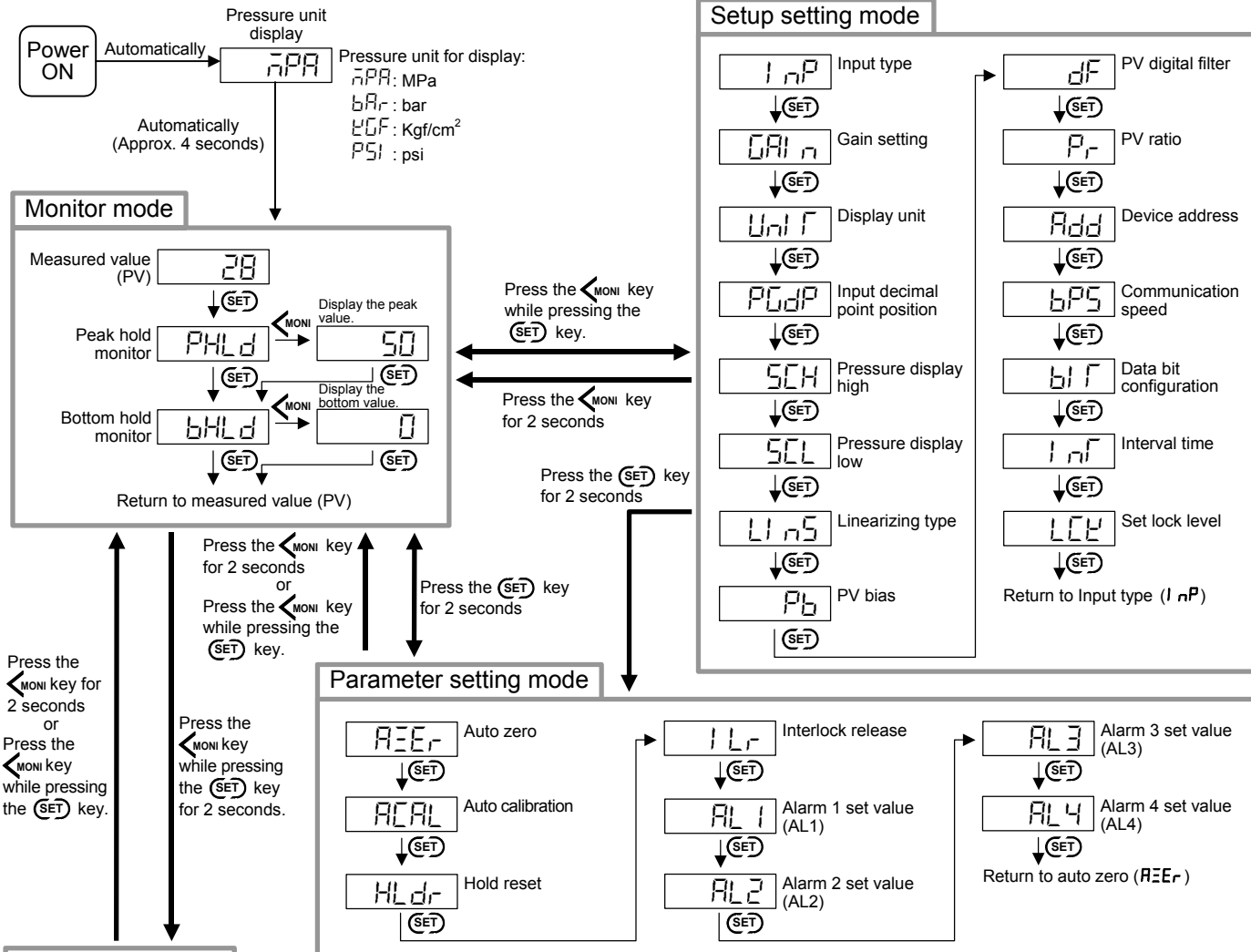

4. PARAMETER LIST

4.1 Monitor Mode

Symbol	Name	Data range	Description
—	Measured value (PV)	Pressure display low to Pressure display high	Display the measured value (PV).
PHLd (PHLd)	Peak hold monitor *	Pressure display low to Pressure display high	Display the maximum value of measured value (PV).
bHLd (bHLd)	Bottom hold monitor *	At input break: Display range limit	Display the minimum value of measured value (PV).

* The hold reset function can be executed by hold reset (HLdr) in parameter setting mode and digital input 2 (DI2, terminal Nos. 13 and 15). Reset also takes place when the power is turned off, or when the set value of Input type (InP), Gain setting (GAI n), Display unit (UnIT), Input decimal point position (PGdP) or Linearizing type (LnS) is changed.

4.2 Setup Setting Mode

Symbol	Name	Data range	Description	Factory set value
InP (InP)	Input type	0 to 4 See Input type and factory set value table	Use to select the input type.	Depends on model code.
GAI n (GAI n)	Gain setting	0.500 to 4.000 mV/V or 0.5000 to 1.9999 mV/V (Varies with the setting of the gain setting decimal point position)	Use to set the gain of pressure sensor. CZ-100P/CZ-200P: See Gain setting and linearizing type	See Input type and factory set value table
UnIT (UnIT)	Display unit	0: Kgf/cm² 2: bar 1: MPa 3: psi	Use to select the display unit for input.	1
PGdP (PGdP)	Input decimal point position	0: No decimal place 1: One decimal place 2: Two decimal places 3: Three decimal places	Use to select the decimal point position of the input display value.	0
SCH (SCH)	Pressure display high	Pressure display low to 19999 (Varies with the setting of the input decimal point position)	Use to set the high limit of the pressure display range.	50
SCL (SCL)	Pressure display low	0 to Pressure display high (Varies with the setting of the input decimal point position)	Use to set the low limit of the pressure display range.	0
LnS (LnS)	Linearizing type	0 to 20 Resistance for sensitivity adjustment built-in pressure sensor. Use a factory set value of "0."	Use to set the linearizing type of our CZ-100P/CZ-200P. CZ-100P/CZ-200P: See Gain setting and linearizing type	0

Input type and factory set value table

Set value	Input type	Factory set value of gain setting (mV/V)
0	Our CZ-100P/CZ-200P (Standard)	1.500
1	Our CZ-100P/CZ-200P (Explosionproof)	1.500
2	Our CZ-100P/CZ-200P (Standard) [Loose nut: 0.0 to 0.5 MPa, Fixed nut: 0 to 5 MPa]	0.650
3	Our CZ-100P/CZ-200P (Explosionproof) [Loose nut: 0.0 to 0.5 MPa, Fixed nut: 0 to 5 MPa]	0.650
4	3.33 mV/V output type (Pressure sensor made by other companies)	3.330

Gain setting and linearizing type (Only our pressure sensor CZ-100P/CZ-200P)

Set the rated output value (mV/V) and linearizing type symbol to gain setting (GAI n) and linearizing type (LnS) engraved on the rated nameplate attached to the pressure sensor housing.

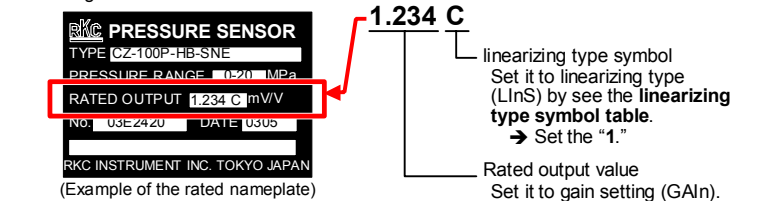

Linearizing type symbol table

Set value	Linearizing type symbol	Set value	Linearizing type symbol	Set value	Linearizing type symbol
0	No symbol	7	J	14	S
1	C	8	K	15	T
2	D	9	L	16	U
3	E	10	M	17	V
4	F	11	P	18	W
5	G	12	Q	19	X
6	H	13	R	20	Y

The rated output value (mV/V) of the CZ-100P/CZ-200P is when the cable is at a length of 5 m. When the cable is extended or a cable of a different manufacturer is used, the gain value must be corrected and changed. For details, see CZ-100P/PCT-300 Resin Pressure Measuring System Instruction Manual (IM100CZ04-E0) or CZ-200P Instruction Manual (IM100CZ08-E0).

Symbol	Name	Data range	Description	Factory set value
P_b (Pb)	PV bias	-Input span to +Input span	PV bias adds bias to the measured value (PV). Manual zero adjustment can be performed.	0
dF (dF)	PV digital filter	0.1 to 100.0 seconds oFF: Unused	This item is the time of the first-order lag filter eliminate noise against the measured input.	oFF
P_r (Pr)	PV ratio	0.500 to 1.500 The setting value varies depending on using pressure sensor. See ● PV ratio.	PV ratio is a multiplier to be applied to the measured value (PV). Manual full scale adjustment can be performed.	1.000
Add (Add)	Device address			
bPS (bPS)	Communication speed		This parameter is displayed when there is the communication function [Optional].	
blT (blT)	Data bit configuration		See the PG500 Communication Instruction Manual (IMR02F03-EC).	
lnT (lnT)	Interval time			
LCK (LCK)	Set lock level	0: Unlock 1: Lock Set to "0" or "1" for each digit.	The set lock level restricts parameter setting changes by key operation (Set data lock function).	0000

- **PV ratio**
[When using our CZ-100P or CZ-200P]
- Explosionproof specification type
Set the desired correction factor of our safety barrier RZB-001 to the PV ratio. Thus, an indicated error caused by the use of the safety barrier is corrected. The correction factor is described in the nameplate attached to the safety barrier (RZB-001).
 - Non-explosionproof specification type
As the PV ratio, use a factory set value of "1.000" with this value left intact.
- **When using resistance for sensitivity adjustment built-in pressure sensor**
The result obtained by auto calibration is reflected to the PV ratio. Manual full scale adjustment can be performed by changing this PV ratio value.

4.3 Parameter Setting Mode

Symbol	Name	Data range	Description	Factory set value
RZE_r (AZEr)	Auto zero *	-5.0 to +5.0 mV (Input conversion)	Adjust the zero point of the measured value (PV). See ● Auto zero.	—
$ACAL$ (ACAL)	Auto calibration	—	Adjust the full scale point of the measured value (PV). See ● Auto calibration.	—
$HLdr$ (HLdr)	Hold reset *	—	Peak hold/bottom hold value is reset.	—
ILr (ILr)	Interlock release *	—	If the alarm state is interlocked, interlock can be released. The interlock states of all alarms are released.	—
$AL1$ (AL1)	Alarm 1 set value	Pressure display low to Pressure display high	Use to set the set value of the alarm action. Signals are output from the alarm outputs (ALM1 to ALM4) if exceeding the alarm set value.	50
$AL2$ (AL2)	Alarm 2 set value	This parameter isn't displayed when the alarm type is set to "0: None."		0
$AL3$ (AL3)	Alarm 3 set value			50
$AL4$ (AL4)	Alarm 4 set value			50

* The auto zero, hold reset and interlock release functions can be executed by turning on the digital input.
D11 (Terminal Nos. 13 and 14): Auto zero D12 (Terminal Nos. 13 and 15): Hold reset
D13 (Terminal Nos. 13 and 16): Interlock release

For the digital input, see the PG500 Installation Manual (IMR02F01-EC).

● Auto zero

- Auto zero is used to automatically set the PV bias (Pb) so that the measured value (PV) will be 0.
- Make sure that the pressure sensor is installed on the equipment.
 - Rise the temperature of the equipment installed with the pressure sensor up to the temperature during operation.
 - Set the pressure sensor to the no-load state.
 - Press the UP key while pressing the DOWN key displaying the Auto zero screen automatically starts auto zero operation. If this auto zero operation normally end, the screen returns to the Measured value (PV) screen.

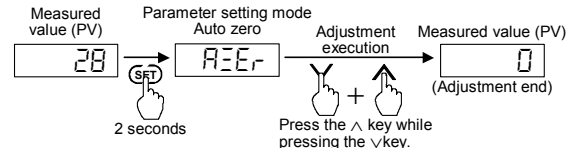

- If error occur, the "RZE_r" and "Err" are displayed alternately on the PV display unit. Press any of the keys (SET key, <MONI key, DOWN key or UP key) to clear the error and return to the measured value (PV) screen.
- The result of auto zero adjustment is also reflected to the PV bias (Pb) value. Manual zero point adjustment can be performed by changing this PV bias value.
- The auto zero can be executed by digital input 1 (DI1, terminal Nos. 13 and 14).

● Auto calibration (Only resistance for sensitivity adjustment built-in pressure sensor)

- Auto calibration is used to automatically set the PV ratio (Pr) so that the measured value (PV) will be the pressure of the shunt resistance output value (SHnT).
- Make sure that the pressure sensor (resistance for sensitivity adjustment built-in pressure sensor) is installed on the equipment.
 - Rise the temperature of the equipment installed with the pressure sensor up to the temperature during operation.
 - Press the UP key while pressing the DOWN key displaying the Auto calibration screen automatically starts auto calibration operation. If this auto calibration operation normally end, the screen returns to the Measured value (PV) screen.

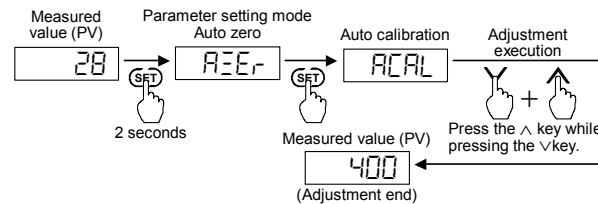

- If error occur, the "ACAL" and "Err" are displayed alternately on the PV display unit. Press any of the keys (SET key, <MONI key, DOWN key or UP key) to clear the error and return to the measured value (PV) screen.
- For this product, in order to generate the R-cal output it is not necessary to short the cables (CAL+ and CAL-) on the pressure sensor side.
- The result obtained by auto calibration is reflected to the PV ratio value. Manual full scale point adjustment can be performed by changing this PV ratio value.

4.4 Engineering Mode

WARNING

Parameters in the Engineering mode (F10 to F91) should be set according to the application before setting any parameter related to operation. Once the Parameters in the Engineering mode are set correctly, those parameters are not necessary to be changed for the same application under normal conditions. If they are changed unnecessarily, it may result in malfunction or failure of the instrument. RKC will not bear any responsibility for malfunction or failure as a result of improper changes in the Engineering mode.

All parameters of the engineering mode are displayed regardless of the instrument specification.

Symbol	Name	Data range	Description	Factory set value
$F10$ (F10)	Function block 10		This is the first parameter symbol of function block 10.	
$dSPT$ (dSPT)	Display timer	0.1 to 10.0 seconds	Use to set the time during which the displayed value is changed.	0.1
$dSoP$ (dSoP)	PV display condition	0 to 63 (Decimal) b0: Minus display of PV value b1: Input error* b2: Alarm 1 occurs b3: Alarm 2 occurs b4: Alarm 3 occurs b5: Alarm 4 occurs Data b0 0: Minus display 1: Non-minus display b1 to b5 0: Non-flashing display 1: Flashing display	Sets the condition for flashing display of the measured value (PV) and minus display of the measured value (PV). When an alarm occurs and flashing is enabled, the measured value (PV) and alarm number are alternately displayed. Bit data 000000 b5.....b0 Set the bit data after converting it to decimal.	0

- When flashing is enabled, the measured value (PV) flashes at the following times:
 - Measured value (PV) exceeds the pressure display high /low.
 - Measured value (PV) exceeds the input error determination point (high/low limit).

Symbol	Name	Data range	Description	Factory set value
$F21$ (F21)	Function block 21		This is the first parameter symbol of function block 21.	
$SHnT$ (SHnT)	Shunt resistance output value	40.0 to 100.0 %	This parameter is valid when using resistance for sensitivity adjustment built-in pressure sensor. It is set "What percentage of the rated output" is output when the full scale point of the measured value (PV) is adjusted by auto calibration.	80.0
PoH (PoV)	Input error determination point (high)	Pressure display low - (5 % of input span) to Pressure display high + (5 % of input span)	If the measured value (PV) is above the input error determination point (high), alarm action at input error will be taken.	53
PUn (PUn)	Input error determination point (low)	Pressure display low - (5 % of input span) to Pressure display high + (5 % of input span)	If the measured value (PV) is below the input error determination point (low), alarm action at input error will be taken.	-2
$brES$ (brKS)	Burnout direction ¹	0: Upscale 1: Downscale	Use to select burnout direction in input break.	0
GdP (GdP)	Gain setting decimal point position	3: Three decimal places 4: Four decimal places	Use to select the decimal point position of the gain setting value.	3
$F33$ (F33)	Function block 33		This is the first parameter symbol of function block 33.	
AHS (AHS)	Transmission output scale high	Transmission output scale low to Pressure display high	Use to set a scale high limit value of the transmission output.	50
ALS (ALS)	Transmission output scale low	Pressure display low to Transmission output scale high	Use to set a scale low limit value of the transmission output.	0
AoT (AoT)	Transmission output timer	0.1 to 10.0 seconds	Use to set the time during which the transmission output value is changed.	0.1
$F41$ (F41)	Function block 41		This is the first parameter symbol of function block 41 to 44.	
$F44$ (F44)	Function block 44		F41: Parameters of alarm 1 F43: Parameters of alarm 3 F42: Parameters of alarm 2 F44: Parameters of alarm 4	
$AS1$ (AS1)	Alarm 1 type	0: None 1: Process high 2: Process low	Use to select the action type of the alarm.	Depends on model code ²
$AS4$ (AS4)	Alarm 4 type			
$AHo1$ (AHo1)	Alarm 1 hold action	0: OFF 1: Hold action ON	Use to select the hold action for the alarm.	Depends on model code ²
$AHo4$ (AHo4)	Alarm 4 hold action			
$ILS1$ (ILS1)	Alarm 1 interlock	0: Unused (OFF) 1: Used	Use to select the interlock function for the alarm.	0
$ILS4$ (ILS4)	Alarm 4 interlock			
$EXC1$ (EXC1)	Alarm 1 energized/de-energized	0: Energized 1: De-energized	Use to select the alarm energized or de-energized.	0
$EXC4$ (EXC4)	Alarm 4 energized/de-energized			
$AH1$ (AH1)	Alarm 1 differential gap	0 to Input span	Use to set a differential gap of the alarm.	2
$AH4$ (AH4)	Alarm 4 differential gap			
$ALT1$ (ALT1)	Alarm 1 delay timer	0.0 to 600.0 seconds	Alarm delay timer is to set an output delay time for alarm outputs	0.0
$ALT4$ (ALT4)	Alarm 4 delay timer			
$AEo1$ (AEo1)	Alarm 1 action at input error	0: Normal alarm action 1: Forced alarm ON when temperature measured value exceeds the input error determination point (high or low limit).	Alarm action at input error is to select the alarm action when the measured value (PV) reaches the input error determination point (high or low limit).	0
$AEo4$ (AEo4)	Alarm 4 action at input error			
$F60$ (F60)	Function block 60		This is the first parameter symbol of function block 60.	
CMP (CMP)	Communication protocol	0: RKC communication 1: Modbus	Use to select a protocol of communication function.	0
$F91$ (F91)	Function block 91		This is the first parameter symbol of function block 91.	
roM (roM)	ROM version monitor	Version of ROM built in the instrument	Displays the version of the ROM on the instrument.	—

¹ Setting of a burnout direction select switch is necessary to select a burnout direction.

For the switch setting, see the PG500 Installation Manual (IMR02F01-EC).

² When not specifying: Alarm 1: Process high (without hold action) Alarm 3: No alarm
Alarm 2: Process low (without hold action) Alarm 4: No alarm

Symbol	Name	Data range	Description	Factory set value
WT (WT)	Integrated operating time monitor	0 to 19999 hours	Displays the integrated total operating time of the instrument.	—

■ Alarm function [Optional]

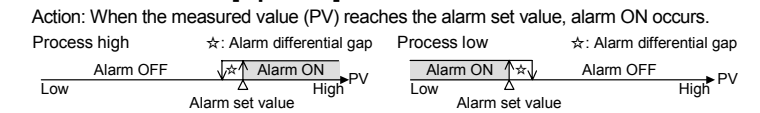

- Alarm hold action**
When hold action is ON, the alarm action is suppressed at start-up (Power ON) until the measured value has entered the non-alarm range.
- Alarm interlock**
The alarm interlock function is used to hold the alarm state even if the measured value (PV) is out of the alarm area after its entry into the area once.
- Alarm differential gap**
It prevents chattering of alarm output due to the measured value fluctuation around the alarm set value.
- Alarm delay timer**
When an alarm condition becomes ON status, the output is suppressed until the delay timer set time elapses. After the time is up, if the alarm output is still ON status, the output will be produced.

■ Transmission output function (AO) [Optional]

- The transmission output function is used to output any measured value (PV) as the voltage/current output. In addition, any range of the measured value (PV) can be output with the transmission output scale low and transmission output scale high set.
- Example: When a measured value (PV) of 10 to 30 MPa needs to be recorded on a recorder at an pressure range of 0 to 50 MPa.
- Output type: Current output, 4 to 20 mA DC
Transmission output scale high (AHS): 30 MPa
Transmission output scale low (ALS): 10 MPa

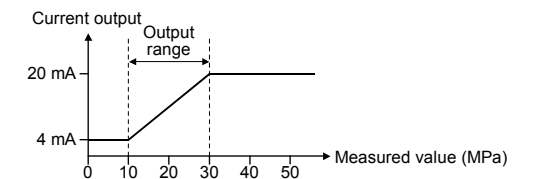

5. ERROR DISPLAYS

■ Display when input error occurs

Prior to replacing the sensor, always turn OFF the power.

Display	Description	Action (Output)	Solution
PV [Flashing] *	PV exceeds the Pressure display high /low. PV exceeds the input error determination point (high/low limit).	Output depending on the alarm action at input error	Check input type, input range, sensor and sensor connection.
0000 [Flashing]	Over-scale PV is above the Pressure display high + (5 % of input span).	Output depending on the normal alarm action	
uuuu [Flashing]	Underscale PV is below the Pressure display low - (5 % of input span)	Output depending on the alarm action at input error	

* The PV flashes depending on the PV display condition (dSoP) of engineering mode F10.

■ Self-diagnostic error

In an error is detected by the self-diagnostic function, the "Err" and error code are displayed alternately on the PV display unit. If two or more errors occur simultaneously, the total summation of these error codes is displayed.

Solution: Turn off the power once. If an error occurs after the power is turned on again, please contact RKC sales office or the agent.

PV display	Description	Action
1	Adjustment data error	Display: Error display (Err and error number) Output: All the output is OFF (Same as power OFF)
2	Back-up error	
4	A/D conversion error	Communication: Send the error code
128	Watchdog timer error	
256	Program error (stack)	
2048	Program error (busy)	
All display is OFF	Power supply voltage monitoring error RAM check error	Display: All display is OFF Output: All output OFF Communication: Stop

Modbus is a registered trademark of Schneider Electric.
Company names and product names used in this manual are the trademarks or registered trademarks of the respective companies.

RKC RKC INSTRUMENT INC. - The first edition: NOV. 2007 [IMQ01]
The second edition: JAN. 2008 [IMQ00]
HEADQUARTERS: 16-6, KUGAHARA 5-CHOME, OHTA-KU TOKYO 146-8515 JAPAN
PHONE: 03-3751-9799 (+81 3 3751 9799) E-mail: info@rkcinst.co.jp
FAX: 03-3751-8585 (+81 3 3751 8585) JAN. 2008