

AG500 Operation Manual

All Rights Reserved. Copyright © 2007, RKC INSTRUMENT INC. **IMR02F07-E2**
 Thank you for purchasing this RKC product. In order to achieve maximum performance and ensure proper operation of your new instrument, carefully read all the instructions in this manual. Please place this manual in a convenient location for easy reference.

This manual describes the operation method of the AG500. For the installation, the parts description, the specifications and the communication function (Optional), please read if necessary the following separate manuals.

- AG500 Installation Manual (IMR02F06-E0): Enclosed with AG500
- AG500 Communication Instruction Manual (IMR02F08-E0): Enclosed with AG500*
- * Only AG500 provided with the communication function

The above manuals can be downloaded from our website:
 URL: http://www.rkcinst.com/english/manual_load.htm

1. HANDLING PROCEDURES

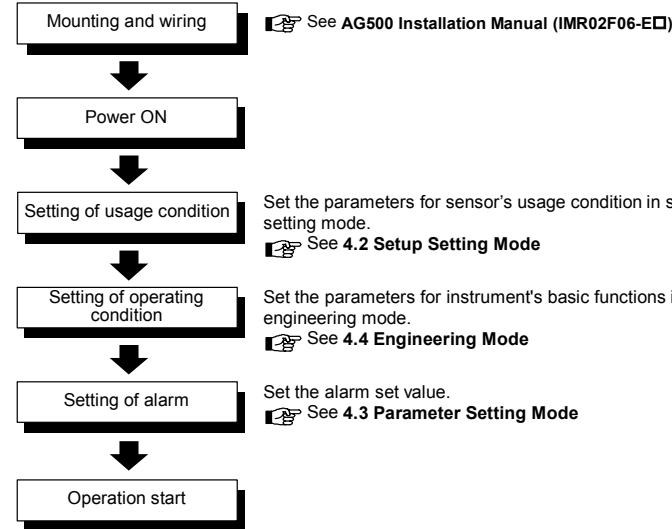

2. CHANGING DATA SETTINGS

- To store a new value for the parameter, always press the SET key.
- After a new value is displayed on the display by using UP and DOWN keys, if no key operation is performed for more than 1 minute without pressing SET key, this instrument returns to the Measured value (PV) screen and the set value will not be changed.

Example: Changing the alarm 1 set value (AL1) to 20 °C

1. Select the alarm 1 set value (AL1) of parameter setting mode

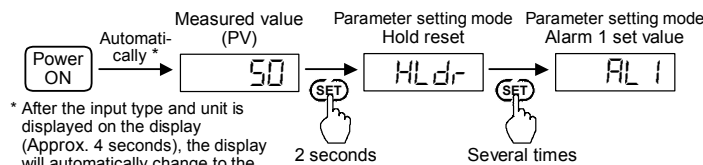

2. Change the alarm 1 set value (AL1) to 20 °C

Pressing the MONI key displays the data display. The high-lighted digit indicates which digit can be set.

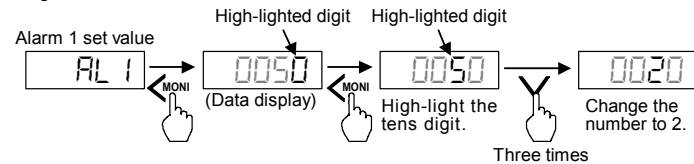

3. Store the alarm 1 set value (AL1)

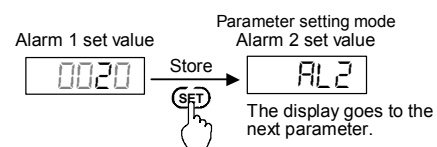

Other data can also be set by the same procedures as described in steps 1 to 3.

3. TRANSFER TO EACH MODE AND PARAMETER

- This instrument return to Measured value (PV) screen, if key operation for more than 1 minute is not performed.
- Any parameter which is not used in the controller will not be displayed except for parameters in engineering mode.

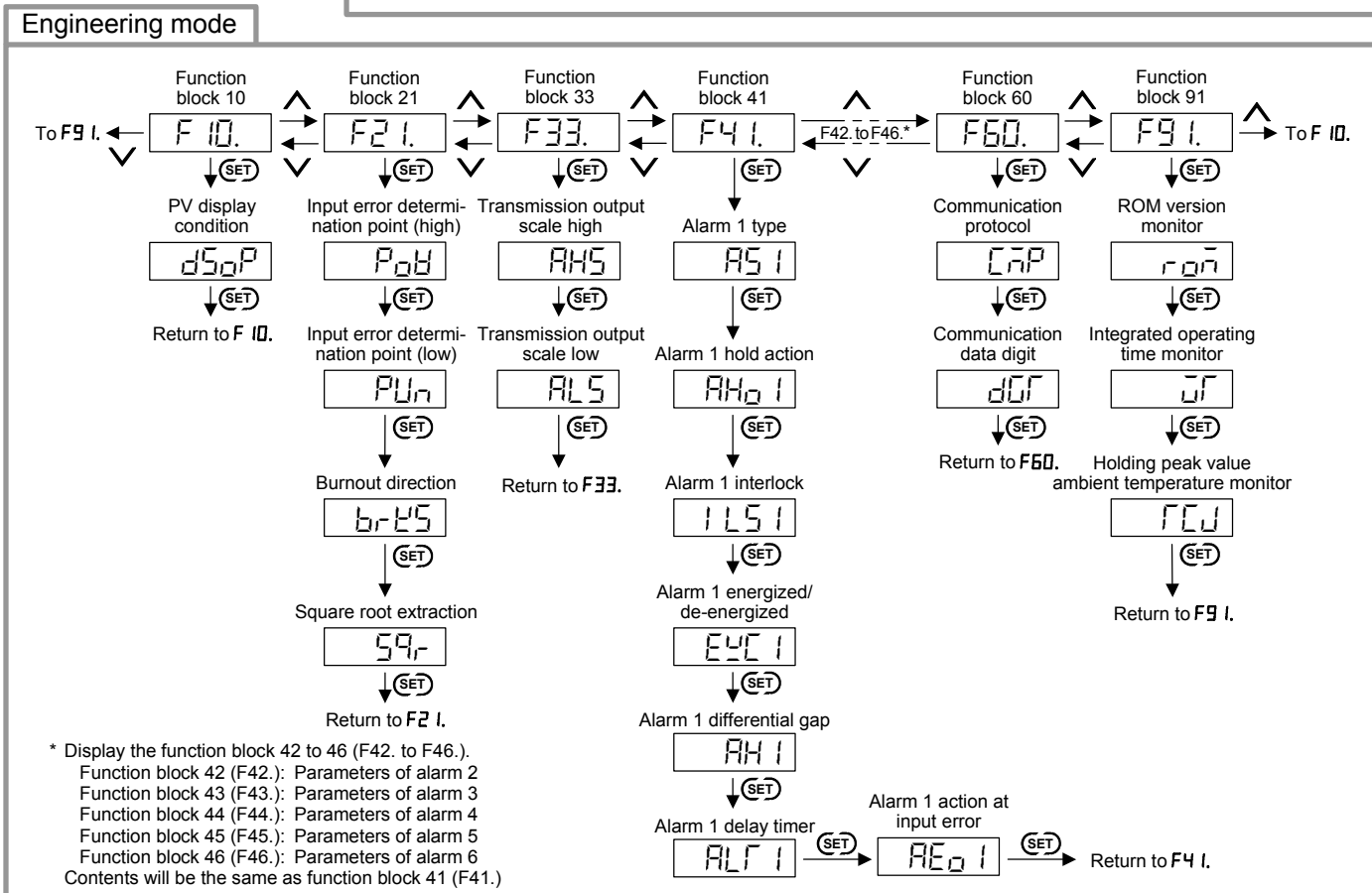
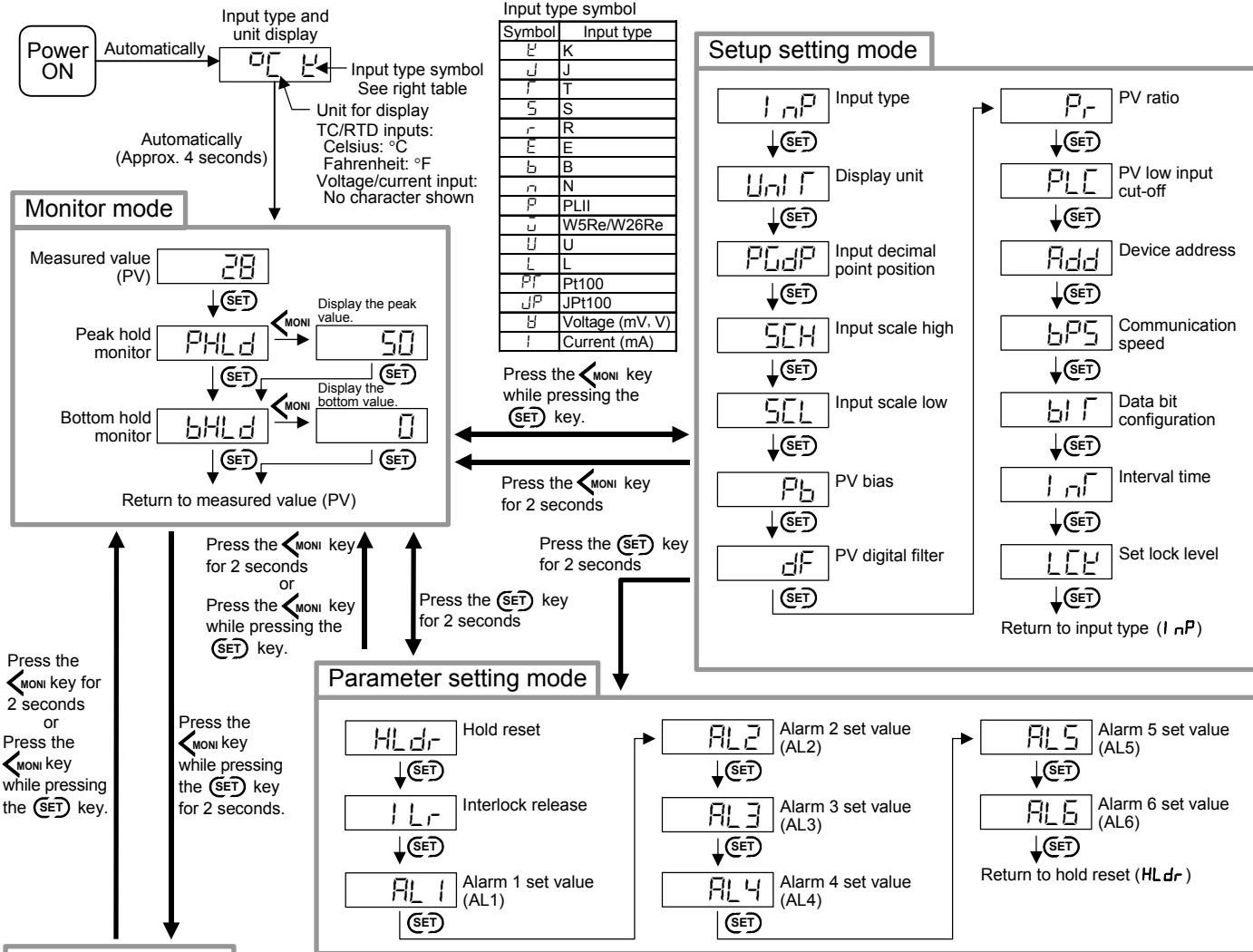

4. PARAMETER LIST

4.1 Monitor Mode

Symbol	Name	Data range	Description
—	Measured value (PV)	Input scale low to Input scale high	Display the measured value (PV).
PHLd (PHLd)	Peak hold monitor ¹	Input scale low to Input scale high	Display the maximum value of measured value (PV).
bHLd (bHLd)	Bottom hold monitor ¹	At input break: Display range limit ²	Display the minimum value of measured value (PV).

¹ The hold reset function can be executed by hold reset (HLdr) in parameter setting mode and digital input 1 (DI1, terminal Nos. 13 and 14). Reset also takes place when the power is turned off, or when the set value of Input type (InP), Display unit (UnIT) or Input decimal point position (PGdP) is changed.
² This item is invalid when using voltage (high) input (0 to 10 V DC, 0 to 5 V DC, 1 to 5 V DC, ±1 V DC) and current input.

4.2 Setup Setting Mode

Symbol	Name	Data range	Description	Factory set value
InP (InP)	Input type	0 to 26 See Input type number table	Use to select the input type.	Depends on model code. When not specifying: 0
UnIT (UnIT)	Display unit	0: °C 1: °F	Use to select the display unit for TC/RTD inputs.	0
PGdP (PGdP)	Input decimal point position ^a	0: No decimal place 1: One decimal place 2: Two decimal places 3: Three decimal places 4: Four decimal places	Use to select the decimal point position of the input display value.	Depends on model code. When not specifying: 0
SCH (SCH)	Input scale high	TC/RTD inputs: Input scale low to Maximum value of the input range Voltage (V)/current (I) inputs: -19999 to +19999 ^b	Use to set the high limit of the input scale range.	TC/RTD inputs: Maximum value of the input range V/I inputs: 100.0
SCL (SCL)	Input scale low	TC/RTD inputs: Minimum value of the input range to Input scale high Voltage (V)/current (I) inputs: -19999 to +19999 ^b	Use to set the low limit of the input scale range.	TC/RTD inputs: Minimum value of the input range V/I inputs: 0.0
Pb (Pb)	PV bias	-Input span to +Input span	PV bias adds bias to the measured value (PV).	0
dF (dF)	PV digital filter	0.1 to 100.0 seconds oFF: Unused	This item is the time of the first-order lag filter eliminate noise against the measured input.	oFF

^a Data range of input decimal point position

Input type	Data range
TC input	Input range without decimal points
RTD input	Input range with one decimal place
	Input range with two decimal place
Voltage (V)/current (I) inputs	[For communication data 6 digits: 0 to 3]

^b For the input range, see the AG500 Installation Manual (IMR02F06-E0).

^c Varies with the setting of the input decimal point position.

Input type number table

Set value	Input type	Hardware	Set value	Input type	Hardware	
0	TC input K	Voltage (low) input group	13	RTD input JPt100	Voltage (low) input group	
1	TC input J		14	Current input 0 to 20 mA DC		
2	TC input R		15	Current input 4 to 20 mA DC		
3	TC input S		19	Voltage (low) input 0 to 1 V DC		
4	TC input B		20	Voltage (low) input 0 to 100 mV DC		
5	TC input E		21	Voltage (low) input 0 to 10 mV DC		
6	TC input N		25	Voltage (low) input ±100 mV DC		
7	TC input T		26	Voltage (low) input ±10 mV DC		
8	TC input W5Re/W26Re		16	Voltage (high) input 0 to 10 V DC		Voltage (high) input group
9	TC input PLII		17	Voltage (high) input 0 to 5 V DC		
10	TC input U		18	Voltage (high) input 1 to 5 V DC		
11	TC input L		24	Voltage (high) input ±1 V DC		
12	RTD input Pt100	22, 23	Don't set this one			

As the input decimal point position, input scale high and input scale low are initialized if the input type is changed, it is necessary to conduct the re-setting.

When the input type is changed to the voltage (low) or voltage (high) input group, it is necessary to transfer the input select switch. Turn the measured value input switch (left side) by a small screwdriver.

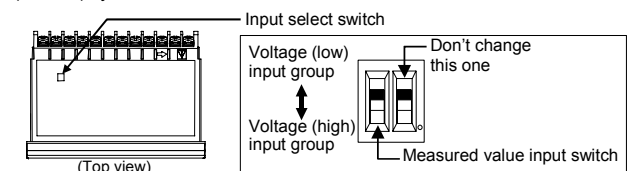

Symbol	Name	Data range	Description	Factory set value
P_r (Pr)	PV ratio	0.500 to 1.500	PV ratio is a multiplier to be applied to the measured value (PV).	1.000
PLC (PLC)	PV low input cut-off	0.00 to 25.00 % of input span This parameter isn't displayed when the square root extraction is set to "0: Unused."	The measured value less than the PV low input cut-off is ignored to prevent control disturbance caused by input variation at low measured value range.	0.00
Rdd (Add)	Device address			
bPS (bPS)	Communication speed	This parameter is displayed when there is the communication function [Optional].		
$bI\Gamma$ (bIT)	Data bit configuration	See the AG500 Communication Instruction Manual (IMR02F08-ED) .		
$I nT$ (InT)	Interval time			
LCK (LCK)	Set lock level	0: Unlock 1: Lock Set to "0" or "1" for each digit.	The set lock level restricts parameter setting changes by key operation (Set data lock function).	0000

Input scale high/low

The input range can be changed for temperature input. For voltage (V)/current (I) inputs, display scaling can be made in the range of -19999 to +19999.

Example of temperature input:

When the range of -200.0 to +800.0 °C for thermocouple type K is changed to 0.0 to 400.0 °C

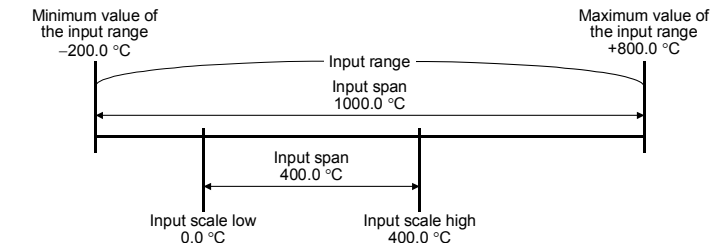

When outside the input scale range, the PV display flashes. The alarm setting range is within the input scale range.

Example of voltage (V)/Current (I) inputs:

When the input scale is changed to "0.0 to 50.0" from "0.0 to 100.0" at a voltage input of 1 to 5 V DC

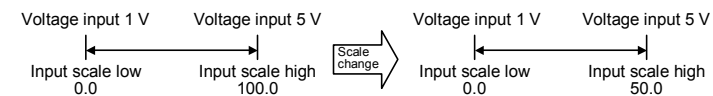

When the voltage input is 1 V → Displays the "0.0"
When the voltage input is 5 V → Displays the "100.0"

4.3 Parameter Setting Mode

Symbol	Name	Data range	Description	Factory set value
$HLdr$ (HLDr)	Hold reset *	—	Peak hold/bottom hold value is reset.	—
ILr (ILr)	Interlock release *	—	If the alarm state is interlocked, interlock can be released. The interlock states of all alarms are released.	—
$AL1$ (AL1)	Alarm 1 set value	Input scale low to Input scale high	Use to set the set value of the alarm action.	50
$AL2$ (AL2)	Alarm 2 set value	This parameter isn't displayed when the alarm type is set to "0: None."	Signals are output from the alarm outputs (ALM1 to ALM6) if exceeding the alarm set value.	50
$AL3$ (AL3)	Alarm 3 set value			50
$AL4$ (AL4)	Alarm 4 set value			50
$AL5$ (AL5)	Alarm 5 set value			50
$AL6$ (AL6)	Alarm 6 set value			50

* The hold reset and interlock release functions can be executed by turning on the digital input. DI1 (Terminal Nos. 13 and 14): Hold reset DI2 (Terminal Nos. 13 and 15): Interlock release

For the digital input, see the **AG500 Installation Manual (IMR02F06-ED)**.

Hold reset

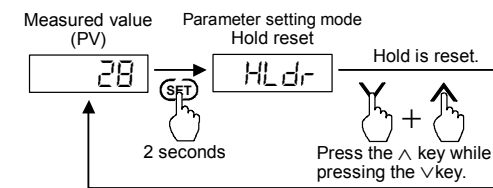

Interlock release

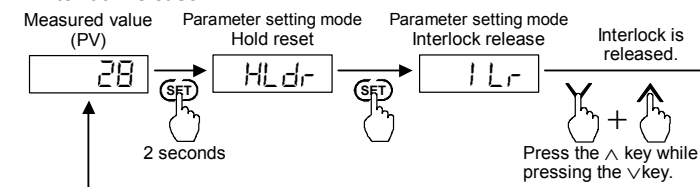

4.4 Engineering Mode

WARNING

Parameters in the Engineering mode (F10 to F91) should be set according to the application before setting any parameter related to operation. Once the Parameters in the Engineering mode are set correctly, those parameters are not necessary to be changed for the same application under normal conditions. If they are changed unnecessarily, it may result in malfunction or failure of the instrument. RKC will not bear any responsibility for malfunction or failure as a result of improper changes in the Engineering mode.

All parameters of the engineering mode are displayed regardless of the instrument specification.

Symbol	Name	Data range	Description	Factory set value
$F10$ (F10)	Function block 10	This is the first parameter symbol of function block 10.		
$dSoP$ (dSoP)	PV display condition	0 to 255 (Decimal) b0: Minus display of PV value b1: Input error* b2: Alarm 1 occurs b3: Alarm 2 occurs b4: Alarm 3 occurs b5: Alarm 4 occurs b6: Alarm 5 occurs b7: Alarm 6 occurs	Sets the condition for flashing display of the measured value (PV) and minus display of the measured value (PV). When an alarm occurs and flashing is enabled, the measured value (PV) and alarm number are alternately displayed.	0
	Data b0	0: Minus display 1: Non-minus display b1 to b7 0: Non-flashing display 1: Flashing display	Bit data 0000000 b7.....b0 Set the bit data after converting it to decimal.	
$F21$ (F21)	Function block 21	This is the first parameter symbol of function block 21.		
PoB (PoV)	Input error determination point (high)	Input scale low - (5 % of input span) to Input scale high + (5 % of input span)	If the measured value (PV) is above the Input error determination point (high), alarm action at input error will be taken.	Note 1
PUn (PUn)	Input error determination point (low)	Input scale low - (5 % of input span) to Input scale high + (5 % of input span)	If the measured value (PV) is below the Input error determination point (low), alarm action at input error will be taken.	Note 1
$brKS$ (brKS)	Burnout direction	0: Upscale 1: Downscale This item is valid when using thermocouple input and voltage (low) input ² .	Use to select burnout direction in input break.	0
SQR (SQR)	Square root extraction	0: Unused 1: Used	Use to select Use/Unuse of the square root extraction for the measured value.	0

¹ When flashing is enabled, the measured value (PV) flashes at the following times:

- Measured value (PV) exceeds the input scale high/low.
- Measured value (PV) exceeds the input error determination point (high/low limit).

² Voltage (low) input: 0 to 10 mV DC, ±10 mV DC, 0 to 100 mV DC, ±100 mV DC, 0 to 1 V DC

Note 1 Factory set value of Input error determination point (high/low)

Input error determination point	TC/RTD inputs	Voltage (V)/current (I) inputs
High	Input scale high + (5 % of input span)	+105.0
Low	Input scale low - (5 % of input span)	-5.0

Symbol	Name	Data range	Description	Factory set value
$F33$ (F33)	Function block 33	This is the first parameter symbol of function block 33.		
AHS (AHS)	Transmission output scale high	Transmission output scale low to Input scale high	Use to set a scale high limit value of the transmission output.	Input scale high
ALS (ALS)	Transmission output scale low	Input scale low to Transmission output scale high	Use to set a scale low limit value of the transmission output.	Input scale low
$F41$ (F41)	Function block 41	This is the first parameter symbol of function block 41 to 46.		
$F46$ (F46)	Function block 46	F41: Parameters of alarm 1 F42: Parameters of alarm 2 F43: Parameters of alarm 3 F44: Parameters of alarm 4 F45: Parameters of alarm 5 F46: Parameters of alarm 6		
$AS1$ (AS1)	Alarm 1 type	0: None 1: Process high 2: Process low	Use to select the action type of the alarm.	Depends on model code. When not specifying: 0
$AS6$ (AS6)	Alarm 6 type			
$AHo1$ (AHo1)	Alarm 1 hold action	0: OFF 1: Hold action ON	Use to select the hold action for the alarm.	Depends on model code. When not specifying: 0
$AHo6$ (AHo6)	Alarm 6 hold action			
$ILS1$ (ILS1)	Alarm 1 interlock	0: Unused (OFF) 1: Used	Use to select the interlock function for the alarm.	0
$ILS6$ (ILS6)	Alarm 6 interlock			
$EXC1$ (EXC1)	Alarm 1 energized/de-energized	0: Energized 1: De-energized	Use to select the alarm energized or de-energized.	0
$EXC6$ (EXC6)	Alarm 6 energized/de-energized			
$AH1$ (AH1)	Alarm 1 differential gap	0 to Input span	Use to set a differential gap of the alarm.	2
$AH6$ (AH6)	Alarm 6 differential gap			
$ALT1$ (ALT1)	Alarm 1 delay timer	0.0 to 600.0 seconds	Alarm delay timer is to set an output delay time for alarm outputs	0.0
$ALT6$ (ALT6)	Alarm 6 delay timer			
$AEo1$ (AEo1)	Alarm 1 action at input error	0: Normal alarm action 1: Forced alarm ON when temperature measured value exceeds the input error determination point (high or low limit).	Alarm action at input error is to select the alarm action when the measured value (PV) reaches the input error determination point (high or low limit).	0
$AEo6$ (AEo6)	Alarm 6 action at input error			
$F60$ (F60)	Function block 60	This is the first parameter symbol of function block 60.		
CMP (CMP)	Communication protocol	0: RKC communication 1: Modbus	Use to select a protocol of communication function.	0
dGT (dGT)	Communication data digit *	0: 6 digits 1: 7 digits	The number of communication data digits in RKC communication	1
$F91$ (F91)	Function block 91	This is the first parameter symbol of function block 91.		
roM (roM)	ROM version monitor	Version of ROM built in the instrument	Displays the version of the ROM on the instrument.	—
WT (WT)	Integrated operating time monitor	0 to 19999 hours	Displays the integrated total operating time of the instrument.	—
TCJ (TCJ)	Holding peak value ambient temperature monitor	-10.0 to +100.0 °C	Displays the maximum ambient temperature of the instrument.	—

* Display range limit is table shown below.

Input decimal point position	Communication data 6 digits	Communication data 7 digits (Factory set value)
No decimal place	-9999 to +19999	-19999 to +19999
One decimal place	-999.9 to +1999.9	-1999.9 to +1999.9
Two decimal places	-99.99 to +199.99	-199.99 to +199.99
Three decimal places	-9.999 to +19.999	-19.999 to +19.999
Four decimal places	None	-1.9999 to +1.9999

Alarm function [Optional]

Action: When the measured value (PV) reaches the alarm set value, alarm ON occurs.

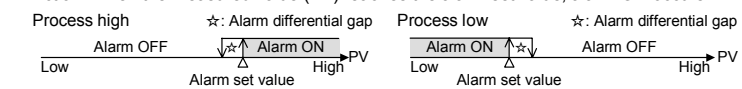

Alarm hold action

When hold action is ON, the alarm action is suppressed at start-up (Power ON) until the measured value has entered the non-alarm range.

Alarm interlock

The alarm interlock function is used to hold the alarm state even if the measured value (PV) is out of the alarm area after its entry into the area once.

Alarm differential gap

It prevents chattering of alarm output due to the measured value fluctuation around the alarm set value.

Alarm delay timer

When an alarm condition becomes ON status, the output is suppressed until the delay timer set time elapses. After the time is up, if the alarm output is still ON status, the output will be produced.

Transmission output function (AO) [Optional]

The transmission output function is used to output any measured value (PV) as the voltage/current output. In addition, any range of the measured value (PV) can be output with the transmission output scale low and transmission output scale high set.

Example: When a measured value (PV) of -100 to +1000 °C needs to be recorded on a recorder at an input range of -200 to +1372 °C.

Output type: Current output, 4 to 20 mA DC
Transmission output scale high (AHS): +1000 °C
Transmission output scale low (ALS): -100 °C

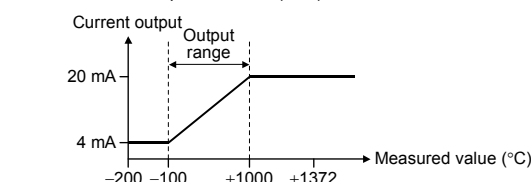

5. ERROR DISPLAYS

Display when input error occurs

Prior to replacing the sensor, always turn OFF the power.

Display	Description	Action (Output)	Solution
PV [Flashing] *	PV exceeds the input scale high/low. PV exceeds the input error determination point (high/low limit).	Output depending on the alarm action at input error	Check input type, input range, sensor and sensor connection.
0000 [Flashing]	Flashes when any of Alarms 1 to 6 has occurred. (The PV and alarm number are displayed alternately)	Output depending on the normal alarm action	
0000 [Flashing]	Over-scale PV is above the input scale high + (5 % of input span).	Output depending on the alarm action at input error	
0000 [Flashing]	Underscale PV is below the input scale low - (5 % of input span)	Output depending on the alarm action at input error	

* The PV flashes depending on the PV display condition (dSoP) of engineering mode F10.

Self-diagnostic error

In an error is detected by the self-diagnostic function, the "Err" and error code are displayed alternately on the PV display unit. If two or more errors occur simultaneously, the total summation of these error codes is displayed.

Solution: Turn off the power once. If an error occurs after the power is turned on again, please contact RKC sales office or the agent.

PV display	Description	Action
1	Adjustment data error	Display: Error display (Err and error number) Output: All the output is OFF (Same as power OFF)
2	Back-up error	
4	A/D conversion error	
128	Watchdog timer error	Communication: Send the error code
256	Program error (stack)	
2048	Program error (busy)	
All display is OFF	Power supply voltage monitoring error	Display: All display is OFF Output: All output OFF
	RAM check error	Communication: Stop

Modbus is a registered trademark of Schneider Electric. Company names and product names used in this manual are the trademarks or registered trademarks of the respective companies.

RKC RKC INSTRUMENT INC. - The first edition: NOV. 2007 [IMQ01]
The second edition: JAN. 2008 [IMQ00]
HEADQUARTERS: 16-6, KUGAHARA 5-CHOME, OHTA-KU TOKYO 146-8515 JAPAN
PHONE: 03-3751-9799 (+81 3 3751 9799) E-mail: info@rkcinst.co.jp
FAX: 03-3751-8585 (+81 3 3751 8585) JAN. 2008