

# Pressure Indicator **AG500** Communication Instruction Manual

All Rights Reserved. Copyright © 2007, RKC INSTRUMENT INC.

IMR02F08-E2

Thank you for purchasing this RKC product. In order to achieve maximum performance and ensure proper operation of your new instrument, carefully read all the instructions in this manual. Please place this manual in a convenient location for easy reference.

This manual describes the communication function of the AG500. For the installation, the parts description, the specifications and the operation method, please read if necessary the following separate manuals.

- AG500 Installation Manual (IMR02F06-E□): Enclosed with AG500
- AG500 Operation Manual (IMR02F07-E□): Enclosed with AG500

The above manuals can be downloaded from our website:  
URL: [http://www.rkcinst.com/english/manual\\_load.htm](http://www.rkcinst.com/english/manual_load.htm)

## 1. CONNECTION TO HOST COMPUTER



**WARNING**

To prevent electric shock or instrument failure, turn off the power before connecting or disconnecting the instrument and peripheral equipment.

The cable must be provided by the customer.

### 1.1 RS-485

#### ■ Communication terminal number and signal details

Terminal No.	Signal name	Symbol
25	Signal ground	SG
26	Send/Receive data	T/R (A)
27	Send/Receive data	T/R (B)

#### ■ When the interface of host computer (Master) is RS-485

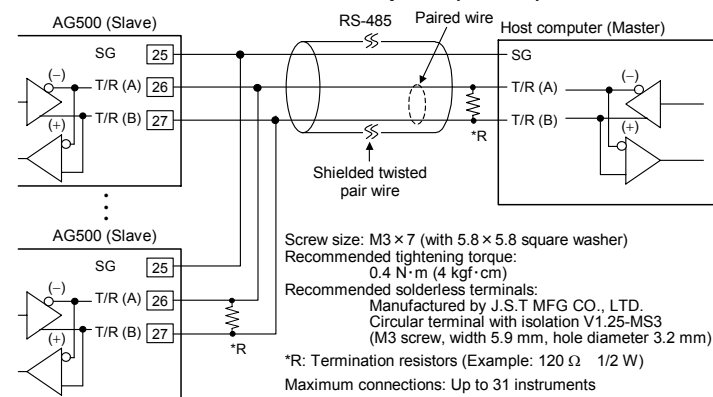

#### ■ When the host computer (Master) has a USB connector

Connect the USB communication converter between the host computer and the AG500.

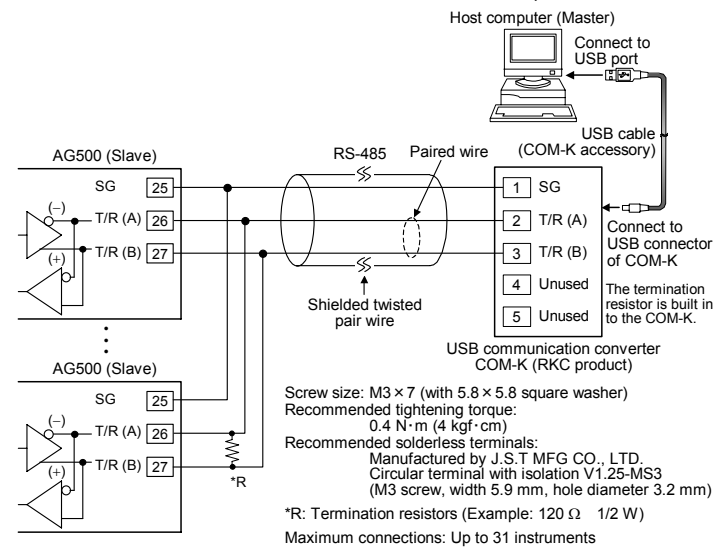

For the COM-K, see the COM-K Instruction Manual (IMR01Z01-E□).

### 1.2 RS-422A

#### ■ Communication terminal number and signal details

Terminal No.	Signal name	Symbol	Terminal No.	Signal name	Symbol
25	Signal ground	SG	28	Receive data	R (A)
26	Send data	T (A)	29	Receive data	R (B)
27	Send data	T (B)			

#### ■ When the interface of host computer (Master) is RS-422A

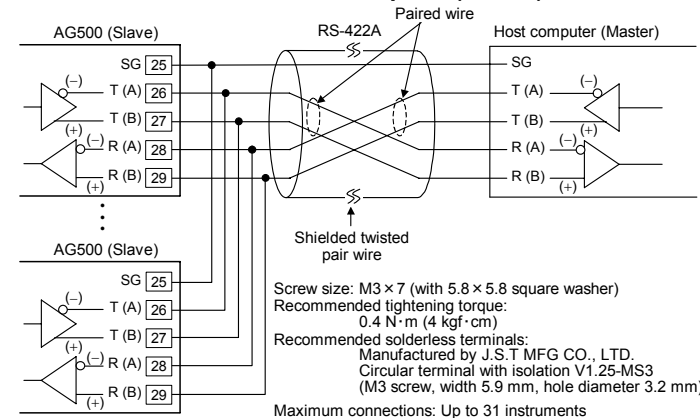

#### ■ When the host computer (Master) has a USB connector

Connect the USB communication converter between the host computer and the AG500.

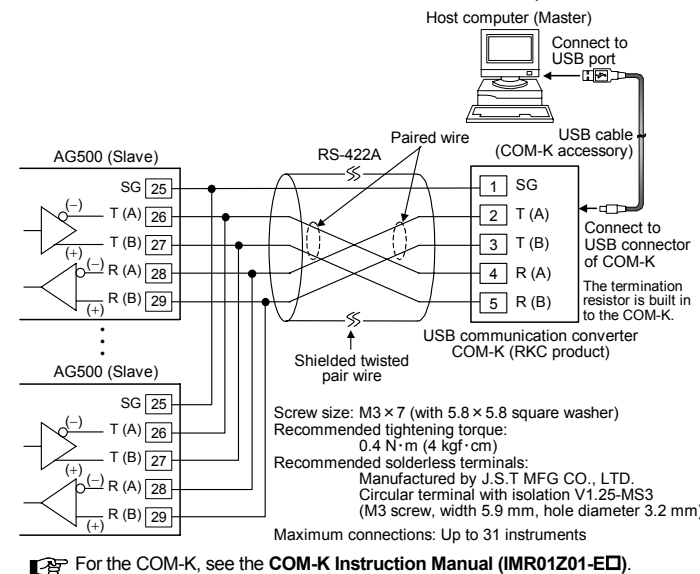

For the COM-K, see the COM-K Instruction Manual (IMR01Z01-E□).

## 2. SETTING

To establish communication parameters between host computer and AG500, it is necessary to set the following parameters.

When all communication parameter settings have been completed, turn the power off and then on to make the new set values take effect.

This section describes the parameters to need setting for communication. For the mode/parameters transfer and data setting, see the AG500 Operation Manual (IMR02F07-E□).

#### ■ Description of each parameters

##### ● Engineering mode F60

Symbol	Name	Data range	Description	Factory set value
F60 (F60)	Function block 60	This is the first parameter symbol of function block 60.		
CMF (CMF)	Communication protocol	0: RKC communication 1: Modbus	Use to select a protocol of communication function.	0
dGT (dGT)	Communication data digit *	0: 6 digits 1: 7 digits	The number of communication data digits in RKC communication	1

\* Display range limit is table shown below.

Input decimal point position	Communication data 6 digits	Communication data 7 digits (Factory set value)
No decimal place	-9999 to +19999	-19999 to +19999
One decimal place	-999.9 to +1999.9	-1999.9 to +1999.9
Two decimal places	-99.99 to +199.99	-199.99 to +199.99
Three decimal places	-9.999 to +19.999	-19.999 to +19.999
Four decimal places	None	-1.9999 to +1.9999

#### ● Setup setting mode

Symbol	Name	Data range	Description	Factory set value
Rdd (Add)	Device address (Slave address)	0 to 99 Maximum connections: Up to 31 instruments	Do not use the same device address for more than one instrument in multi-drop connection. Each instrument must have a unique address in multi-drop connection. In Modbus communication, communication is not possible when the address is 0.	0
bPS (bPS)	Communication speed	1.2: 1200 bps 2.4: 2400 bps 4.8: 4800 bps 9.6: 9600 bps 19.2: 19200 bps 38.4: 38400 bps	Set the same communication speed for both the AG500 (slave) and the host computer (master).	19.2
bl (bIT)	Data bit configuration	See Data bit configuration table	Set the same data bit configuration for both the AG500 (slave) and the host computer (master).	8n1
l (lnT)	Interval time	0 to 250 ms	The interval time for the AG500 should be set to provide a time for host computer to finish sending all data including stop bit and to switch the line to receive status for the host.	10

#### Data bit configuration table

Set value	Data bit	Parity bit	Stop bit	Set value	Data bit	Parity bit	Stop bit
Bn1	8	Without	1	ln1*	7	Without	1
Bn2	8	Without	2	ln2*	7	Without	2
BE1	8	Even	1	ne1*	7	Even	1
BE2	8	Even	2	ne2*	7	Even	2
BO1	8	Odd	1	no1*	7	Odd	1
BO2	8	Odd	2	no2*	7	Odd	2

\* When the Modbus communication protocol selected, this setting becomes invalid.

#### Interval time:

The interval time for the AG500 should be set to provide a time for host computer to finish sending all data including stop bit and to switch the line to receive status for the host. If the interval time between the two is too short, the AG500 may send data before the host computer is ready to receive it. In this case, communication transmission cannot be conducted correctly.

## 3. COMMUNICATION REQUIREMENTS

#### ■ Processing times during data send/receive

When the host computer is using either the polling or selecting procedure for communication, the following processing times are required for AG500 to send data:

- Response wait time after AG500 sends BCC in polling procedure
- Response wait time after AG500 sends ACK or NAK in selecting procedure

Response send time is time at having set interval time in 0 ms.

#### RKC communication (Polling procedure)

Procedure details	Time
Response send time after AG500 receives ENQ	3 ms max.
Response send time after AG500 receives ACK	3 ms max.
Response send time after AG500 receives NAK	3 ms max.
Response send time after AG500 sends BCC	1 ms max.

#### RKC communication (Selecting procedure)

Procedure details	Time
Response send time after AG500 receives BCC	34 ms max.
Response wait time after AG500 sends ACK	1 ms max.
Response wait time after AG500 sends NAK	1 ms max.

#### Modbus

Procedure details	Time
Read holding registers [03H] Response send time after the slave receives the query message (When 125 registers are collectively read)	360 ms max.
Preset single register [06H] Response send time after the slave receives the query message	25 ms max.
Diagnostics (loopback test) [08H] Response send time after the slave receives the query message	16 ms max.
Preset multiple registers [10H] Response send time after the slave receives the query message (When 123 registers are collectively write)	360 ms max.

#### ■ RS-485 (2-wire system) send/receive timing (RKC communication)

RS-485 communication is conducted through two wires, therefore the transmission and reception of data requires precise timing.

#### Polling procedure

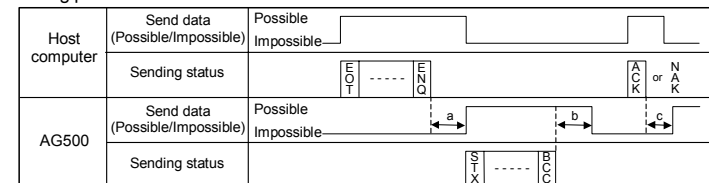

a: Response send time after the controller receives [ENQ] + Interval time  
b: Response send time after the controller sends BCC  
c: Response send time after the controller receives [ACK] + Interval time or Response send time after the controller receives [NAK] + Interval time

#### Selecting procedure

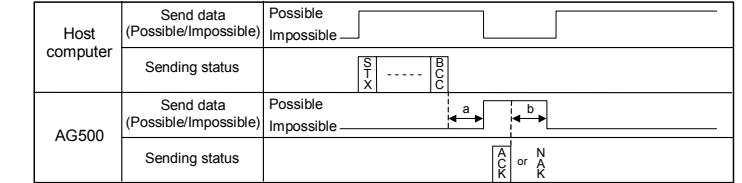

a: Response send time after the controller receives BCC + Interval time  
b: Response wait time after the controller sends ACK or Response wait time after the controller sends NAK

To switch the host computer from transmission to reception, send data must be on line.

The following processing times are required for the AG500 to process data.  
- In Polling procedure, Response wait time after the AG500 sends BCC  
- In Selecting procedure, Response wait time after the AG500 sends ACK or NAK

#### ■ RS-422A/RS-485 fail-safe

A transmission error may occur with the transmission line disconnected, shorted or set to the high-impedance state. In order to prevent the above error, it is recommended that the fail-safe function be provided on the receiver side of the host computer. The fail-safe function can prevent a framing error from its occurrence by making the receiver output stable to the MARK (1) when the transmission line is in the high-impedance state.

#### ■ Modbus data processing precautions

- The numeric range of data used in Modbus protocol is 0000H to FFFFH. Only the set value within the setting range is effective.  
FFFFH represents -1.
- Data with decimal point is treated as data without decimal point on the Modbus protocol.
- If data (holding register) exceeding the accessible address range is accessed, an error response message is returned.
- Read data of unused item is a default value.
- Any attempt to write to an unused item is not processed as an error. Data can not be written into an unused item.
- If data range or address error occurs during data writing, it is not processed as an error. Except the data that error occurred, normal data is written in data register. Therefore, it is necessary to confirm data after the end of setting data.
- Communication data includes data that becomes RO (read only) depending on the specification. No error occurs even if data is written when set to RO. However in this case, no data is written.
- Send the next command message at time intervals of 30 bits after the master receives the response message.

## 4. COMMUNICATION DATA LIST

The communication data map shows data which can be used for communication between the host computer and AG500.

Explanation of data map items

- Modbus register address  
HEX: Hexadecimal DEC: Decimal
- Attribute (A method of how communication data items are read or written when viewed from the host computer is described)  
RO: Only reading data is possible (Host computer ← AG500)  
R/W: Reading and writing data is possible (Host computer ↔ AG500)
- Data

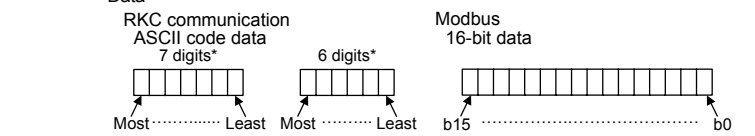

\* The number of communication data digits in RKC communication varies with the setting of the communication data digit (dGT).

Name	RKC Identifier	Modbus register address		Attribute	Data range	Factory set value
		HEX	DEC			
Model code	ID	—	—	RO	Model character code (32-digit)	—
ROM version monitor	VR	—	—	RO	Version of ROM built in the instrument (8-digit)	—
Measured value (PV)	M1	00E0	224	RO	Input scale low to Input scale high	—
Burnout state monitor	B1	00E1	225	RO	0: OFF 1: ON	—
Alarm 1 state monitor	AA	00E2	226	RO	0: OFF 1: ON	—
Alarm 2 state monitor	AB	00E3	227	RO	—	—
Alarm 3 state monitor	AC	00E4	228	RO	—	—
Alarm 4 state monitor	AD	00E5	229	RO	—	—
Alarm 5 state monitor	AE	00E6	230	RO	—	—
Alarm 6 state monitor	AF	00E7	231	RO	—	—
Peak hold monitor	HP	00E8	232	RO	Input scale low to Input scale high	—
Bottom hold monitor	HQ	00E9	233	RO	At input break: Display range limit *	—

\* This item is invalid when using voltage (high) input (0 to 10 V DC, 0 to 5 V DC, 1 to 5 V DC, ±1 V DC) and current input.

Name	RKC Identifier	Modbus register address		Attribute	Data range	Factory set value
		HEX	DEC			
Error code	ER	00EA	234	RO	RKC communication 1: Adjustment data error 2: Back-up error 4: A/D conversion error 128: Watchdog timer error 256: Program error (stack) 2048: Program error (busy)  Modbus (Bit data) b0: Adjustment data error b1: Back-up error b2: A/D conversion error b3 to b6: Unused b7: Watchdog timer error b8: Program error (stack) b9: Unused b10: Unused b11: Program error (busy) b12 to b15: Unused Data 0: OFF 1: ON [Decimal number: 0 to 2439]	—
Digital input (DI) state monitor	L1	00EB	235	RO	RKC communication Least significant digit: The state of hold reset (DI1) 2nd digit: The state of Interlock release (DI2) 3rd digit to Most significant digit: Unused Data 0: Contact open 1: Contact closed  Modbus (Bit data) b0: The state of hold reset (DI1) b1: The state of Interlock release (DI2) b2 to b15: Unused Data 0: Contact open 1: Contact closed [Decimal number: 0 to 3]	—
Alarm output state monitor	Q1	00EC	236	RO	RKC communication Least significant digit to 6th digit: The state of alarm 1 output to alarm 6 output Most significant digit: Unused Data 0: OFF 1: ON  Modbus (Bit data) b0 to b5: The state of alarm 1 output to alarm 6 output b6 to b15: Unused Data 0: OFF 1: ON [Decimal number: 0 to 63]	—
Integrated operating time monitor	UT	00ED	237	RO	0 to 19999 hours	—
Holding peak value ambient temperature monitor	HT	00EE	238	RO	-10.0 to +100.0 °C	—
Unused	—	00EF : 239 : 241	—	—	—	—
Hold reset	HR	00F2	242	R/W	0: Hold reset execution 1: Hold state	1 <sup>a</sup>
Interlock release <sup>b</sup>	IR	00F3	243	R/W	0: Interlock release execution 1: Interlock state	1 <sup>a</sup>
Alarm 1 set value <sup>c</sup>	A1	00F4	244	R/W	Input scale low to Input scale high	50
Alarm 2 set value <sup>c</sup>	A2	00F5	245	R/W	Input scale low to Input scale high	50
Alarm 3 set value <sup>c</sup>	A3	00F6	246	R/W	Signals are output from the alarm outputs (ALM1 to ALM6) if exceeding the alarm set value.	50
Alarm 4 set value <sup>c</sup>	A4	00F7	247	R/W	Input scale low to Input scale high	50
Alarm 5 set value <sup>c</sup>	A5	00F8	248	R/W	Input scale low to Input scale high	50
Alarm 6 set value <sup>c</sup>	A6	00F9	249	R/W	Input scale low to Input scale high	50
Input type	XI	00FA	250	R/W	0: K 14: 0 to 20 mA DC 1: J 15: 4 to 20 mA DC 2: R 16: 0 to 10 V DC 3: S 17: 0 to 5 V DC 4: B 18: 1 to 5 V DC 5: E 19: 0 to 1 V DC 6: N 20: 0 to 100 mV DC 7: T 21: 0 to 10 mV DC 8: W5Re/W26Re 9: PLI 24: ±1 V DC 10: U 25: ±100 mV DC 11: L 26: ±10 mV DC 12: P1100 13: JPT100 22, 23: Don't set this one	Depends on model code. When not specifying: 0
Unused	—	00FB	251	—	—	—

<sup>a</sup> When "0" is written, the interlock is released or hold reset is performed. When done, the value reverts to "1."  
<sup>b</sup> This item is invalid when the alarm 1 to 6 Interlock are set to "0: Unused."  
<sup>c</sup> This item is invalid when the alarm type is set to "0: None."

Name	RKC Identifier	Modbus register address		Attribute	Data range	Factory set value
		HEX	DEC			
Display unit	PU	00FC	252	R/W	0: °C 1: °F	0
Input decimal point position <sup>a</sup>	XU	00FD	253	R/W	0: No decimal place 1: One decimal place 2: Two decimal places 3: Three decimal places 4: Four decimal places	Depends on model code. When not specifying: 0
Input scale high	XV	00FE	254	R/W	TC/RTD inputs: Input scale low to Maximum value of the input range Voltage (V)/current (I) inputs: -19999 to +19999 <sup>b</sup>	TC/RTD inputs: Maximum value of the input range V/I inputs: 100.0
Input scale low	XW	00FF	255	R/W	TC/RTD inputs: Minimum value of the input range to Input scale high Voltage (V)/current (I) inputs: -19999 to +19999 <sup>b</sup>	TC/RTD inputs: Minimum value of the input range V/I inputs: 0.0
Unused	—	0100	256	—	—	—
PV bias	PB	0101	257	R/W	-Input span to +Input span	0
PV digital filter	F1	0102	258	R/W	0.0 to 100.0 seconds (0.0: Unused)	0
PV ratio	PR	0103	259	R/W	0.500 to 1.500	1.000
PV low input cut-off <sup>c</sup>	DP	0104	260	R/W	0.00 to 25.00 % of input span	0.00
Set lock level	LK	0105	261	R/W	RKC communication Least significant digit: Items other than alarm set value. 2nd digit: Alarm set value 3rd digit to Most significant digit: Unused Data 0: Unlock 1: Lock	0
Unused	—	0106	262	—	—	—
PV display condition	DU	0107	263	R/W	RKC communication 0 to 255 (Decimal) Set the bit data (See Modbus) after converting it to decimal.  Modbus (Bit data) b0: Minus display of PV value <sup>d</sup> b1: Input error b2: Alarm 1 occurs b3: Alarm 2 occurs b4: Alarm 3 occurs b5: Alarm 4 occurs b6: Alarm 5 occurs b7: Alarm 6 occurs b8 to b15: Unused Data 0: Minus display 1: Non-minus display b1 to b7: 0: Non-flashing display 1: Flashing display [Decimal number: 0 to 255]	0
Input error determination point (high)	AV	0108	264	R/W	Input scale low - (5 % of input span) to Input scale high + (5 % of input span)	Note 1
Input error determination point (low)	AW	0109	265	R/W	Input scale low - (5 % of input span) to Input scale high + (5 % of input span)	Note 1
Burnout direction <sup>e</sup>	IB	010A	266	R/W	0: Upscale 1: Downscale	0

<sup>a</sup> Data range of input decimal point position

Input type		Data range
TC input RTD input	Input range without decimal points	0
	Input range with one decimal place	0, 1
	Input range with two decimal places	0 to 2
Voltage (V)/current (I) inputs [For communication data 6 digits: 0 to 3]		0 to 4

<sup>b</sup> For the input range, see the AG500 Installation Manual (IMR02F06-E).  
<sup>c</sup> Varies with the setting of the input decimal point position.  
<sup>d</sup> This item is invalid when the square root extraction is set to "0: Unused."  
<sup>e</sup> This item is valid when using thermocouple input and voltage (low) input.  
Voltage (low) input: 0 to 10 mV DC, ±10 mV DC, 0 to 100 mV DC, 0 to 1 V DC

Note 1 Factory set value of Input error determination point (high/low)

Input error determination point	TC/RTD inputs	Voltage (V)/current (I) inputs
High	Input scale high + (5 % of input span)	+105.0
Low	Input scale low - (5 % of input span)	-5.0

Name	RKC Identifier	Modbus register address		Attribute	Data range	Factory set value
		HEX	DEC			
Unused	—	010B	267	—	—	—
Square root extraction	XH	010C	268	R/W	0: Unused 1: Used	0
Unused	—	010D	269	—	—	—
Transmission output scale high	HV	010E	270	R/W	Transmission output scale low to Input scale high	Input scale high
Transmission output scale low	HW	010F	271	R/W	Input scale low to Transmission output scale high	Input scale low
Unused	—	0110	272	—	—	—
Alarm 1 type	XA	0111	273	R/W	0: None 1: Process high 2: Process low	Depends on model code. When not specifying: 0
Alarm 1 hold action	WA	0112	274	R/W	0: OFF 1: Hold action ON	Depends on model code. When not specifying: 0
Alarm 1 interlock	QA	0113	275	R/W	0: Unused (OFF) 1: Used	0
Alarm 1 energized/de-energized	NA	0114	276	R/W	0: Energized 1: De-energized	0
Alarm 1 differential gap	HA	0115	277	R/W	0 to Input span	2
Alarm 1 delay timer	TD	0116	278	R/W	0.0 to 600.0 seconds	0.0
Alarm 1 action at input error	OA	0117	279	R/W	0: Normal alarm action 1: Forced alarm ON when temperature measured value exceeds the input error determination point (high or low limit).	0
Alarm 2 type	XB	0118	280	R/W	Same as Alarm 1 type	
Alarm 2 hold action	WB	0119	281	R/W	Same as Alarm 1 hold action	
Alarm 2 interlock	QB	011A	282	R/W	Same as Alarm 1 interlock	
Alarm 2 energized/de-energized	NB	011B	283	R/W	Same as Alarm 1 energized/de-energized	
Alarm 2 differential gap	HB	011C	284	R/W	Same as Alarm 1 differential gap	
Alarm 2 delay timer	TG	011D	285	R/W	Same as Alarm 1 delay timer	
Alarm 2 action at input error	OB	011E	286	R/W	Same as Alarm 1 action at input error	
Alarm 3 type	XC	011F	287	R/W	Same as Alarm 1 type	
Alarm 3 hold action	WC	0120	288	R/W	Same as Alarm 1 hold action	
Alarm 3 interlock	QC	0121	289	R/W	Same as Alarm 1 interlock	
Alarm 3 energized/de-energized	NC	0122	290	R/W	Same as Alarm 1 energized/de-energized	
Alarm 3 differential gap	HC	0123	291	R/W	Same as Alarm 1 differential gap	
Alarm 3 delay timer	TH	0124	292	R/W	Same as Alarm 1 delay timer	
Alarm 3 action at input error	OC	0125	293	R/W	Same as Alarm 1 action at input error	
Alarm 4 type	XD	0126	294	R/W	Same as Alarm 1 type	
Alarm 4 hold action	WD	0127	295	R/W	Same as Alarm 1 hold action	
Alarm 4 interlock	QD	0128	296	R/W	Same as Alarm 1 interlock	
Alarm 4 energized/de-energized	ND	0129	297	R/W	Same as Alarm 1 energized/de-energized	
Alarm 4 differential gap	HD	012A	298	R/W	Same as Alarm 1 differential gap	
Alarm 4 delay timer	TI	012B	299	R/W	Same as Alarm 1 delay timer	
Alarm 4 action at input error	OD	012C	300	R/W	Same as Alarm 1 action at input error	
Alarm 5 type	XE	012D	301	R/W	Same as Alarm 1 type	
Alarm 5 hold action	WE	012E	302	R/W	Same as Alarm 1 hold action	
Alarm 5 interlock	QE	012F	303	R/W	Same as Alarm 1 interlock	
Alarm 5 energized/de-energized	NE	0130	304	R/W	Same as Alarm 1 energized/de-energized	
Alarm 5 differential gap	HE	0131	305	R/W	Same as Alarm 1 differential gap	
Alarm 5 delay timer	TJ	0132	306	R/W	Same as Alarm 1 delay timer	
Alarm 5 action at input error	OK	0133	307	R/W	Same as Alarm 1 action at input error	
Alarm 6 type	XF	0134	308	R/W	Same as Alarm 1 type	
Alarm 6 hold action	WF	0135	309	R/W	Same as Alarm 1 hold action	
Alarm 6 interlock	QF	0136	310	R/W	Same as Alarm 1 interlock	
Alarm 6 energized/de-energized	NF	0137	311	R/W	Same as Alarm 1 energized/de-energized	
Alarm 6 differential gap	HF	0138	312	R/W	Same as Alarm 1 differential gap	
Alarm 6 delay timer	TK	0139	313	R/W	Same as Alarm 1 delay timer	
Alarm 6 action at input error	OU	013A	314	R/W	Same as Alarm 1 action at input error	

## 5. HOW TO USE MODBUS DATA MAPPING

In this communication, it is possible to continuously read/write data by freely specifying 16 sets of data.

Register address to specify mapping data: **1000H to 100FH**  
Register address to actually read/write data: **1500H to 150FH**  
Register address of data which can be mapped: See 4. COMMUNICATION DATA LIST.

Example: When mapping Measured value (PV), Alarm 1 state monitor, Alarm 2 state monitor and Alarm output state monitor to the register addresses from 1500H to 1503H

For data mapping Factory set value (-1: No mapping)			Mapping data		
Name	Register address		Name	Register address	
	HEX	DEC		HEX	DEC
Setting 1 (For 1500H)	1000	4096	Measured value (PV)	00E0	224
Setting 2 (For 1501H)	1001	4097	Alarm 1 state monitor	00E2	226
Setting 3 (For 1502H)	1002	4098	Alarm 2 state monitor	00E3	227
Setting 4 (For 1503H)	1003	4099	Alarm output state monitor	00EC	236
...	...	...	...	...	...
Setting 16 (For 150FH)	100F	4111			

Write to 1000H to 1003H.

- The register address, "00E0H" of the "Measured value (PV)" to be mapped is written to register address setting 1 (1000H).
- The register address, "00E2H" of the "Alarm 1 state monitor" to be mapped is written to register address setting 2 (1001H).
- The register address, "00E3H" of the "Alarm 2 state monitor" to be mapped is written to register address setting 3 (1002H).
- The register address, "00ECH" of the "Alarm output state monitor" to be mapped is written to register address setting 4 (1003H).
- The assignment of the register addresses from 1500H to 1503H from/to which data is actually read/written becomes as follows.

Register address		Name
HEX	DEC	
1500	5376	Measured value (PV)
1501	5377	Alarm 1 state monitor
1502	5378	Alarm 2 state monitor
1503	5379	Alarm output state monitor

High-speed communication is performed by reading or writing data in the consecutive register addresses from 1500H to 1503H.

## 6. MODBUS ERROR CODE

Problem	Probable cause	Solution
Error code 1	Function code error (Specifying nonexistent function code)	Confirm the function code
Error code 2	When the mismatched address is specified	Confirm the address of holding register
Error code 3	When the specified number of data items in the query message exceeds the maximum number of data items available	Confirm the setting data
Error code 4	Self-diagnostic error	Turn off the power to the instrument. If the same error occurs when the power is turned back on, please contact RKC sales office or the agent.

## 7. COMMUNICATION SPECIFICATIONS

Interface: Based on RS-422A or RS-485, EIA standard  
Synchronous method: Start-stop synchronous type  
Communication speed: 1200 bps, 2400 bps, 4800 bps, 9600 bps, 19200 bps, 38400 bps  
Data bit configuration: Start bit: 1  
Data bit: RKC communication: 7 or 8  
Modbus: 8  
Parity bit: Without, Odd or Even  
Stop bit: 1 or 2  
Connection method: RS-422A: 4-wire system, half-duplex multi-drop connection  
RS-485: 2-wire system, half-duplex multi-drop connection  
Protocol: • RKC communication (ANSI X3.28-1976 subcategory 2.5, A4)  
Error control: Vertical parity (With parity bit selected)  
Horizontal parity (BCC check)  
Communication code: ASCII 7-bit code  
Xon/Xoff control: None  
• Modbus  
Signal transmission mode: Remote Terminal Unit (RTU) mode  
Function code: 03H (Read holding registers)  
06H (Preset single register)  
08H (Diagnostics: loopback test)  
10H (Preset multiple registers)  
Error check method: CRC-16  
Maximum connections: Up to 31 instruments  
Termination resistor: Externally connected (Example: 120 Ω 1/2W)  
Interval time: 0 to 250 ms  
Signal logic: RS-422A, RS-485

Signal voltage	Logic
V (A) - V (B) ≥ 2 V	0 (SPACE)
V (A) - V (B) ≤ -2 V	1 (MARK)

Voltage between V (A) and V (B) is the voltage of (A) terminal for the (B) terminal.

Modbus is a registered trademark of Schneider Electric.  
Company names and product names used in this manual are the trademarks or registered trademarks of the respective companies.