

Thank you for purchasing this RKC product. In order to achieve maximum performance and ensure proper operation of your new instrument, carefully read all the instructions in this manual. Please place the manual in a convenient location for easy reference.

**WARNING**

- To prevent injury to persons, damage to instrument and equipment, a suitable external protection device shall be required.
- All wiring must be completed before power is turned on to prevent electric shock, fire or damage to instrument and equipment.
- This instrument must be used in accordance with the specifications to prevent fire or damage to instrument and equipment.
- This instrument is not intended for use in locations subject to flammable or explosive gases.
- Do not touch high-voltage connections such as power supply terminals, etc. to avoid electric shock.
- RKC is not responsible if this instrument is repaired, modified or disassembled by other than factory-approved personnel. Malfunction can occur and warranty is void under these conditions.

CAUTION

- This product is intended for use with industrial machines, test and measuring equipment. (It is not designed for use with medical equipment and nuclear energy.)
- This is a Class A instrument. In a domestic environment, this instrument may cause radio interference, in which case the user may be required to take additional measures.
- This instrument is protected from electric shock by reinforced insulation. Provide reinforced insulation between the wire for the input signal and the wires for instrument power supply, source of power and loads.
- Be sure to provide an appropriate surge control circuit respectively for the following:
 - If input/output or signal lines within the building are longer than 30 meters.
 - If input/output or signal lines leave the building, regardless the length.
- This instrument is designed for installation in an enclosed instrumentation panel. All high-voltage connections such as power supply terminals must be enclosed in the instrumentation panel to avoid electric shock by operating personnel.
- All precautions described in this manual should be taken to avoid damage to the instrument or equipment.
- All wiring must be in accordance with local codes and regulations.
- All wiring must be completed before power is turned on to prevent electric shock, instrument failure, or incorrect action. The power must be turned off before repairing work for input break and output failure including replacement of sensor, contactor or SSR, and all wiring must be completed before power is turned on again.
- To prevent instrument damage as a result of failure, protect the power line and the input/output lines from high currents with a suitable overcurrent protection device with adequate breaking capacity such as a fuse, circuit breaker, etc.
- Prevent metal fragments or lead wire scraps from falling inside instrument case to avoid electric shock, fire or malfunction.
- Tighten each terminal screw to the specified torque found in the manual to avoid electric shock, fire or malfunction.
- For proper operation of this instrument, provide adequate ventilation for heat dispensation.
- Do not connect wires to unused terminals as this will interfere with proper operation of the instrument.
- Turn off the power supply before cleaning the instrument.
- Do not use a volatile solvent such as paint thinner to clean the instrument. Deformation or discoloration will occur. Use a soft, dry cloth to remove stains from the instrument.
- To avoid damage to instrument display, do not rub with an abrasive material or push front panel with a hard object.
- When high alarm with hold action/re-hold action is used for Alarm function, alarm does not turn on while hold action is in operation. Take measures to prevent overheating which may occur if the control device fails.

NOTICE

- This manual assumes that the reader has a fundamental knowledge of the principles of electricity, process control, computer technology and communications.
- The figures, diagrams and numeric values used in this manual are only for purpose of illustration.
- RKC is not responsible for any damage or injury that is caused as a result of using this instrument, instrument failure or indirect damage.
- RKC is not responsible for any damage and/or injury resulting from the use of instruments made by imitating this instrument.
- Periodic maintenance is required for safe and proper operation of this instrument. Some components have a limited service life, or characteristics that change over time.
- Every effort has been made to ensure accuracy of all information contained herein. RKC makes no warranty expressed or implied, with respect to the accuracy of the information. The information in this manual is subject to change without prior notice.
- No portion of this document may be reprinted, modified, copied, transmitted, digitized, stored, processed or retrieved through any mechanical, electronic, optical or other means without prior written approval from RKC.

1. PRODUCT CHECK

SA200 - - * - / / /Y
 SA201 (1) (2) (3) (4) (5) (6) (7) (8) (9) (10) (11) (12)

(1) Control action

F: PID action with autotuning (Reverse action)
 D: PID action with autotuning (Direct action)
 W: Heat/Cool PID action with autotuning (Water cooling)¹
 A: Heat/Cool PID action with autotuning (Air cooling)¹

(2) Input type/Range code: Refer to 9. INPUT RANGE TABLE**(3) Output 1 [OUT1] (Control output or Alarm output)**

M: Relay contact output V: Voltage pulse output

(4) Output 2 [OUT2] (Control output or Alarm output)

N: No output M: Relay contact output V: Voltage pulse output

(5) Power supply voltage

3: 24 V AC/DC 4: 100 to 240 V AC

(6) Alarm 1 [ALM1] and (7) Alarm 2 [ALM2]

N: No alarm H: Process high alarm
 A: Deviation high alarm J: Process low alarm
 B: Deviation low alarm K: Process high alarm²
 C: Deviation high/low alarm L: Process low alarm²
 D: Band alarm R: Control loop break alarm (LBA)³
 E: Deviation high alarm² V: SV high alarm
 F: Deviation low alarm² W: SV low alarm
 G: Deviation high/low alarm²

(8) Optional function

N: No function D: Contact input (RUN/STOP, STEP)
 5: RS-485 (RKC communication) 6: RS-485 (Modbus)

(9) Waterproof/Dustproof

N: No Waterproof/Dustproof 1: Waterproof/Dustproof

(10) Case color

N: White A: Black

(11) Output assignment code

No symbol: Standard output⁴
 03: PID action + ALM1 [OUT1: Control output OUT2: ALM1 output⁵]
 04: PID action + ALM1, ALM2
 [OUT1: Control output OUT2: AND output of ALM1 and ALM2⁶]
 05: PID action + ALM1, ALM2
 [OUT1: Control output OUT2: OR output of ALM1 and ALM2⁵]
 06: PID action + ALM1, ALM2
 [OUT1: Control output OUT2: AND output of ALM1 and ALM2⁵]
 07: PID action + ALM1, ALM2 or ALM1 only
 [OUT1: Control output OUT2: No output (The alarm state can be checked via communication or by lamp lighting)]
 08: PID action + ALM1, ALM2 [OUT1: Control output OUT2: ALM1 output⁶
 (ALM2 can be checked via communication or by lamp lighting)]
 09: ALM1 + ALM2 [OUT1: ALM1 output⁶ OUT2: ALM2 output⁶]
 10: ALM1 + ALM2 [OUT1: ALM1 output⁶ OUT2: ALM2 output⁵]
 11: ALM1 + ALM2 [OUT1: ALM1 output⁵ OUT2: ALM1 output⁵]

(12) Version symbol

No code: For Japanese domestic market /Y: For International market

¹ No self-tuning function is provided in the W or A control action type.

² With hold action

³ LBA can be selected for only ALM1. ⁵ De-energized

⁴ PID action: ⁶ Energized

OUT1: Control output

OUT2: No alarm, ALM1 (Energized) or OR output of ALM1 and ALM2 (Energized)

Heat/Cool PID action:

OUT1: Heat-side control output OUT2: Cool-side control output

Accessories

Mounting brackets: 2 Instruction Manual (IMR01D01-E7): 1
 Mounting screws: 2

2. MOUNTING**WARNING**

To prevent electric shock or instrument failure, always turn off the power before mounting or removing the instrument.

2.1 Mounting Cautions

- This instrument is intended to be used under the following environmental conditions. (IEC61010-1)
 [OVERVOLTAGE CATEGORY II, POLLUTION DEGREE 2]
- Use this instrument within the following environmental conditions:
 - Allowable ambient temperature: 0 to 50 °C
 - Allowable ambient humidity: 5 to 95 %RH (Absolute humidity: MAX. W. C 29.3 g/m³ dry air at 101.3 kPa)
 - Installation environment conditions: Indoor use, Altitude up to 2000 m
- Avoid the following conditions when selecting the mounting location:
 - Rapid changes in ambient temperature which may cause condensation.
 - Corrosive or inflammable gases.
 - Direct vibration or shock to the mainframe.
 - Water, oil, chemicals, vapor or steam splashes.
 - Excessive dust, salt or iron particles.
 - Excessive induction noise, static electricity, magnetic fields or noise.
 - Direct air flow from an air conditioner.
 - Exposure to direct sunlight.
 - Excessive heat accumulation.
- Mount this instrument in the panel considering the following conditions:
 - Provide adequate ventilation space so that heat does not build up.
 - Do not mount this instrument directly above equipment that generates large amount of heat (heaters, transformers, semi-conductor functional devices, large-wattage resistors.)

- If the ambient temperature rises above 50 °C, cool this instrument with a forced air fan, cooler, etc. Cooled air should not blow directly on this instrument.
 - In order to improve safety and the immunity to withstand noise, mount this instrument as far away as possible from high voltage equipment, power lines, and rotating machinery.
High voltage equipment: Do not mount within the same panel.
Power lines: Separate at least 200 mm.
Rotating machinery: Separate as far as possible.
- (5) In case this instrument is connected to a supply by means of a permanent connection, a switch or circuit-breaker shall be included in the installation. This shall be in close proximity to the equipment and within easy reach of the operator. It shall be marked as the disconnecting device for the equipment.

2.2 Dimensions

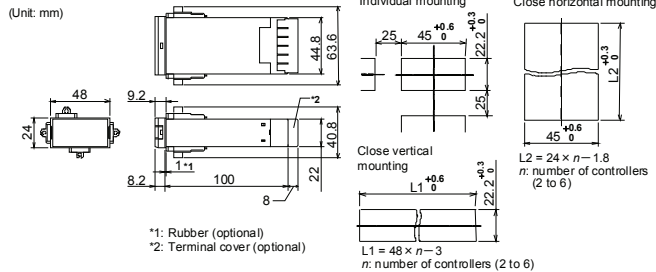

For mounting of the SA200/201, panel thickness must be between 1 to 10 mm. When mounting multiple SA200/201 close together, the panel strength should be checked to ensure proper support.



Installation Conditions:

The display can not be seen from the outside of the visual field range. The visual field range of SA200/201 is 40 degrees to the upper side, and 30 degrees to the lower side from the center of the display vertically.

2.3 Mounting Procedures

1. Prepare the panel cutout as specified in 2.2 Dimensions.
2. Insert the instrument through the panel cutout.
3. Insert the mounting bracket into the mounting groove of the instrument. (Fig.1)
4. Push the mounting bracket forward with a blade screwdriver until the bracket is firmly secured to the panel. (Fig.2)
5. The other mounting bracket should be installed the same way as described in 3. and 4.

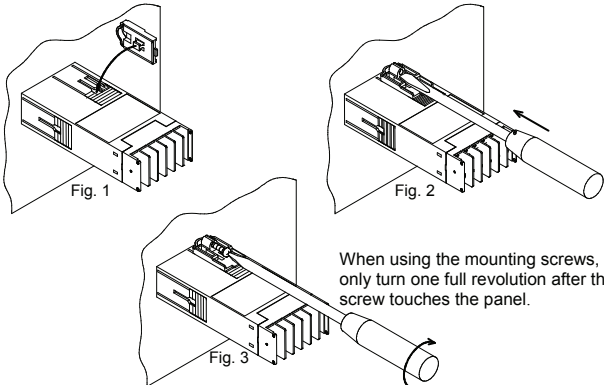

When the instrument is individually mounted, always secure with two mounting brackets either top and bottom or right and left.



In addition, the mounting assembly also include two screws which can be used with the brackets to secure the instrument to the panel. Refer to Fig. 3.



The waterproof/dustproof option on the front of the instrument conforms to IP66 when mounted on the panel. For effective waterproof/dustproof, the gasket must be securely placed between instrument and panel without any gap. If gasket is damaged, please contact RKC sales office or the agent.

Close Mounting

Secure the mounting brackets in the positions as shown in Fig.4 and Fig.5.

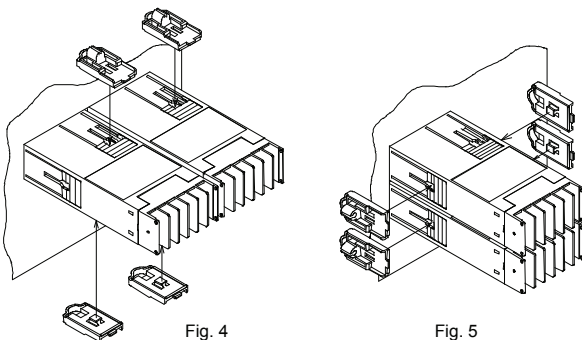

If the SA200/201 have waterproof/dustproof options, protection will be compromised and not meet IP66 by close mounting.



Two units of SA200/201 cannot be inserted into a panel cutout of 48 × 48 mm.

3. WIRING



WARNING

- To prevent electric shock or instrument failure, do not turn on the power until all wiring is completed. Make sure that the wiring is correct before applying power to the instrument.
- To prevent electric shock or instrument failure, turn off the power before connecting or disconnecting the instrument and peripheral equipment.

3.1 Wiring Cautions

- For thermocouple input, use the appropriate compensation wire.
- For RTD input, use low resistance lead wire with no difference in resistance between the three lead wires.
- To avoid noise induction, keep input signal wire away from instrument power line, load lines and power lines of other electric equipment.
- Signal connected to Voltage input and Current input shall be low voltage defined as "SELV" circuit per IEC 60950-1.
- If there is electrical noise in the vicinity of the instrument that could affect operation, use a noise filter.
 - Shorten the distance between the twisted power supply wire pitches to achieve the most effective noise reduction.
 - Always install the noise filter on a grounded panel. Minimize the wiring distance between the noise filter output and the instrument power supply terminals to achieve the most effective noise reduction.
 - Do not connect fuses or switches to the noise filter output wiring as this will reduce the effectiveness of the noise filter.
- Allow approximately 4 seconds for contact output when the instrument is turned on. Use a delay relay when the output line is used for an external interlock circuit.
- Power supply wiring must be twisted and have a low voltage drop.
- This instrument with 24 V power supply is not provided with an overcurrent protection device. For safety install an overcurrent protection device (such as fuse) with adequate breaking capacity close to the instrument.
 - Fuse type: Time-lag fuse (Approved fuse according IEC60127-2 and/or UL248-14)
 - Recommended fuse rating: Rated current 0.4 A
- For the current input specification, an external resistor (250 Ω ±0.02 %, 0.25 W or more, ±10 ppm/°C) must be connected between the input terminals. For external resistor (shunt resistor), use the KD100-55 (RKC product). If this resistor is installed, close vertical mounting is not possible.
- For an instrument with 24 V power supply input, supply power from "SELV" circuit defined as IEC 60950-1.
- A suitable power supply should be considered in end-use equipment. The power supply must be in compliance with a limited-energy circuits (maximum available current of 8 A).
- The input and output terminals for the voltage pulse output are not isolated. Always use an isolating type SSR. If the grounded type sensor is used, do not ground output wiring. Do not connect any output wires to the terminals with any other output wires.

3.2 Restrictions on Wiring

- Always use recommended solderless terminal lugs or equal.

Screw size:

M3 × 6 (With 5.8 × 5.8 square washer)

Recommended tightening torque:

0.4 N·m (4 kgf·cm)

Applicable wire:

Solid/twisted wire of 2 mm²

Recommended solderless terminals:

Circular terminal with isolation

(M3 screw, width 5.5 mm, hole diameter 3.2 mm)

- Make sure that during field wiring parts of conductors can not come into contact with adjacent conductive parts.
- Always connect external wires starting from the lower terminals (No.1 to 6). Disconnect the wires starting from the upper terminals (No.7 to 12).
- When multiple instruments are vertically closely mounted, do not connect two or more solderless terminal lugs to one terminal.
- If multiple instruments are vertically closely mounted, it is necessary to bend the terminal lugs when they are connected to the lower terminals. (Fig. 6)

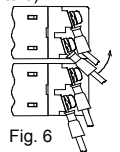
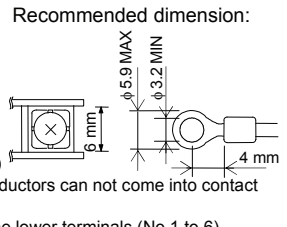

3.3 Terminal Configuration

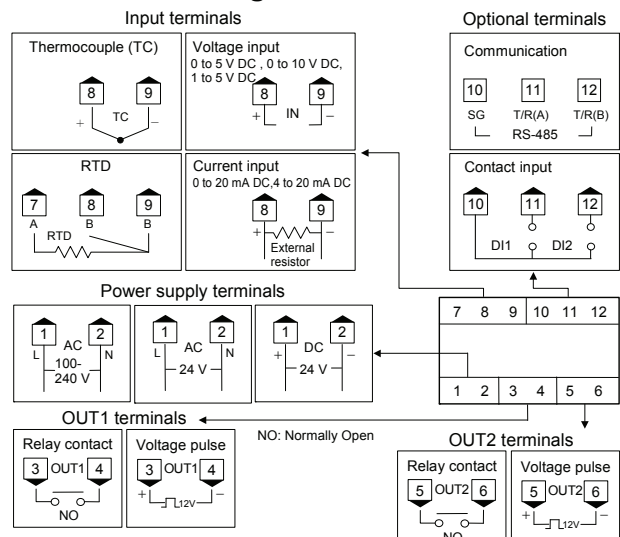

Specifications

Input:

Input type:

Thermocouple (TC): K, J, R, S, B, E, T, N, PLII, W5Re/W26Re, U, L
 Input impedance: Approx. 1 MΩ
 Pt100, JPt100
 Voltage: 0 to 5 V DC, 1 to 5 V DC, 0 to 10 V DC
 Current: 0 to 20 mA DC, 4 to 20 mA DC
 Sampling cycle: 0.5 seconds
 Input range: Refer to Input range table

Control method:

PID control (ON/OFF, P, PI, or PD actions is available)

Outputs (OUT1, OUT2):

Relay contact output: 240 V AC, 2 A (Resistive load) 1a contact
 Electrical life 150,000 times or more (Rated load)
 Voltage pulse output: Input/output terminals are not isolated.
 0/12 V DC (Load resistance 600 Ω or more)

Contact input (optional):

Dry contact input: At open 500 kΩ or more
 At close 10 Ω or less

Performance:

Display accuracy (at the ambient temperature 23 °C ±2 °C):

Thermocouple (TC): ±(0.3 % of display value +1 digit) or ±2 °C [4 °F]
 R, S and B input: 0 to 399 °C [0 to 751 °F] (Accuracy is not guaranteed.)
 T and U input: -199.9 to -100.0 °C [-199.9 to -148.0 °F] (Accuracy is not guaranteed.)

RTD: ±(0.3 % of display value +1 digit) or ±0.8 °C [1.6 °F]
 Voltage/Current: ±(0.3 % of span +1 digit)

Memory backup:

Backed up by Nonvolatile Memory
 Number of write times: Approx. 100,000 times
 Data storage period: Approx. 10 years

Power:

Power supply voltage:

85 to 264 V AC (Power supply voltage range), 50/60 Hz
 Rating: 100 to 240 V AC
 21.6 to 26.4 V AC (Power supply voltage range), 50/60 Hz
 Rating: 24 V AC
 21.6 to 26.4 V DC (Power supply voltage range)
 Rating: 24 V DC

Power consumption:

4 VA max. (at 100 V AC) 7 VA max. (at 240 V AC)
 4 VA max. (at 24 V AC) 100 mA max. (at 24 V DC)

Weight: Approx. 110 g

4. PARTS DESCRIPTION

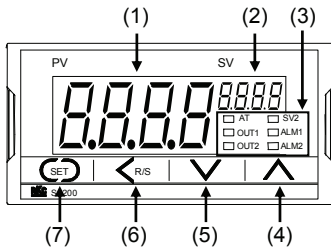

(1) Measured value (PV) display [SA200: Green SA201: Red]
 Displays PV or various parameter symbols.

(2) Set value (SV) display [Orange]
 Displays SV or STEP set value (SV1, SV2).
 Displays various parameter set values.

(3) Indication lamps
Autotuning (AT) lamp [Green]
 Flashes when autotuning is activated.
 (After autotuning is completed: AT lamp will go out)

Output lamps (OUT1, OUT2) [Green]

OUT1: Lights when output 1 is turned on.

OUT2: Lights when output 2 is turned on.

STEP set value (SV2) lamp [Orange]

Lights when the SV2 of STEP function is selected.

Alarm lamps (ALM1, ALM2) [Orange]

ALM1: Lights when alarm 1 is turned on.

ALM2: Lights when alarm 2 is turned on.

(4) UP key

Increase numerals.

(5) DOWN key

Decrease numerals.

(6) Shift & R/S key

Shift digits when settings are changed.

Selects the RUN/STOP function.

(7) Set key

Used for parameter calling up and set value registration.



To avoid damage to the instrument, never use a sharp object to press keys.

5. SETTING

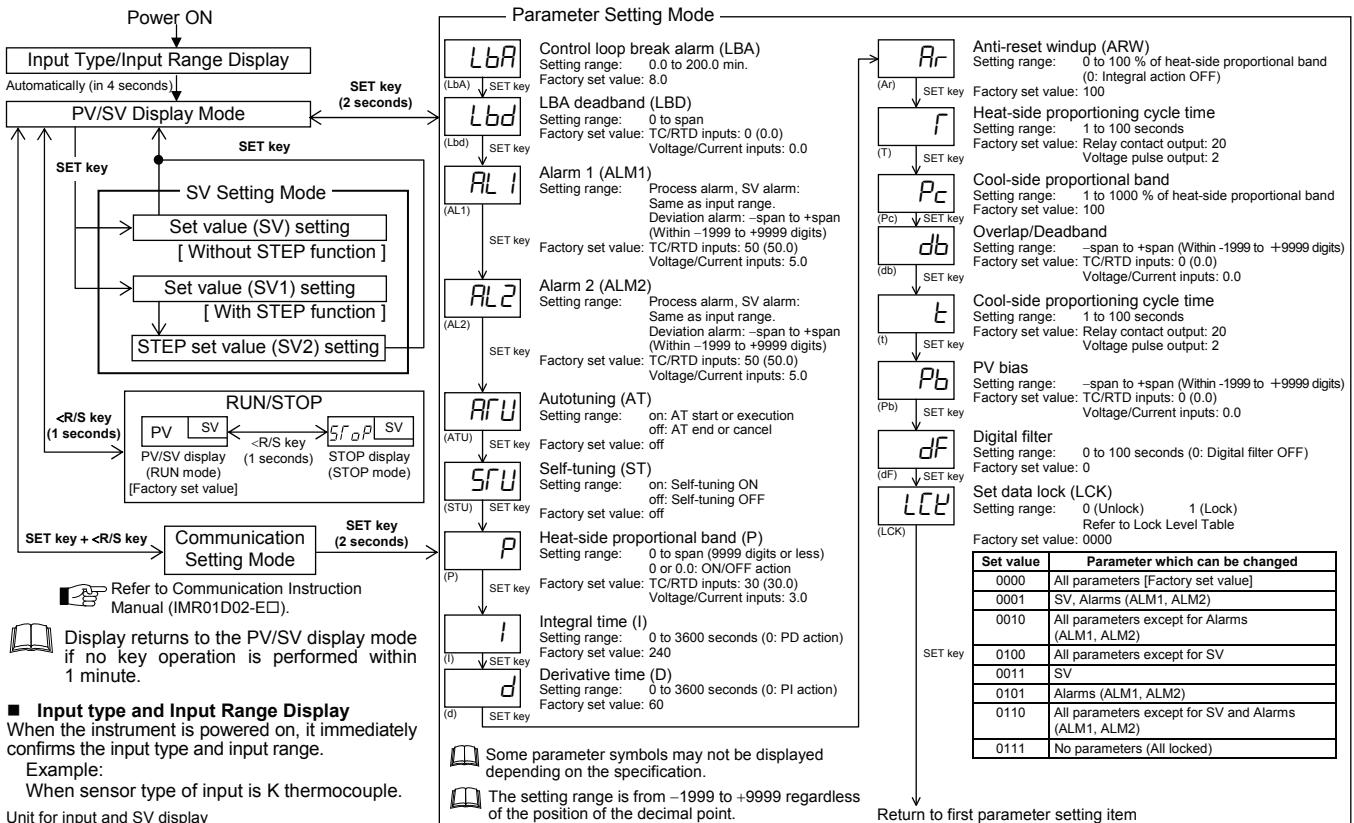

Input type and Input Range Display

When the instrument is powered on, it immediately confirms the input type and input range.

Example:

When sensor type of input is K thermocouple.

Unit for input and SV display
 (Celsius: °C, Fahrenheit: °F, Voltage/Current: no character shown)

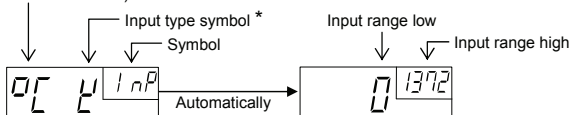

* Input Type Symbol Table

Symbol	Input type
K	Thermocouple (TC)
J	Thermocouple (TC)
R	Thermocouple (TC)
S	Thermocouple (TC)
B	Thermocouple (TC)
E	Thermocouple (TC)
T	Thermocouple (TC)
N	Thermocouple (TC)
PLII	Thermocouple (TC)
W5Re	Thermocouple (TC)
W26Re	Thermocouple (TC)
U	Thermocouple (TC)
L	Thermocouple (TC)
JPt100	RTD
Pt100	RTD
V	Voltage (Current)

PV/SV Display Mode

- The controller will display the measured value (PV) and the set value (SV).
- If the STEP function is provided, the SV display will show the set value (SV1) or STEP set value (SV2) depending on whether the contact input is opened or closed.
- The controller can be switched to RUN or STOP mode.

SV Setting Mode

The blinking digit on the SV display indicates which digit can be set.

Setting range: Within input range

Factory set value: TC/RTD inputs 0 (0.0) °C [°F], Voltage/Current inputs 0.0 %

If the STEP function is provided, the following parameter symbols are displayed on the PV.

Set value (SV1): 541 STEP set value (SV2): 542

■ Changing Parameter Settings

Procedures to change parameter settings are shown below.

To store a new value for the parameter, always press the SET key. The display changes to the next parameter and the new value will be stored.

- A new value will not be stored without pressing SET key after the new value is displayed on the display.
- After a new value has been displayed by using the UP and DOWN keys, the SET key must be pressed within 1 minute, or the new value is not stored and the display will return to the PV/SV display mode.

When the set data is locked, the digits on the SV display are brightly lit and the set value cannot be changed.

● Change the Set value (SV)

Change the Set value (SV) from 0 °C to 200 °C

1. Select the SV setting mode

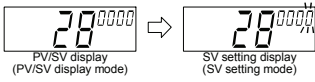

Press the SET key at PV/SV monitor screen until SV setting screen is displayed.

2. Shift the blinking digit



Press the <R/S key to blink the hundreds digit. The blinking digit indicates which digit can be set.

3. Change the set value



Press the UP key to change the number to 2.

4. Store the set value

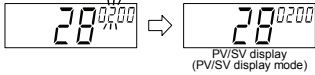

Press the SET key to store the new set value. The display returns to the PV/SV display mode.

● Change parameters other than the set value (SV)

The changing procedures are the same as those of example 2. to 4. in the above "● Change the Set value (SV)." Pressing the SET key after the setting end shifts to the next parameter. When no parameter setting is required, return the instrument to the PV/SV display mode.

6. OPERATION

6.1 Operating Precautions

- (1) All mounting and wiring must be completed before the power is turned on.
- (2) The settings for the SV and all parameters should be appropriate for the controlled object.
- (3) A power supply switch is not furnished with this instrument. It is ready to operate as soon as the power is turned on.
[Factory set value: RUN (operation start)]

Connect the input signal wiring and turn the power on. If the input signal wiring is not complete prior to turning the power on, the instrument determines that burnout has occurred.

A power failure of 20 ms or less will not affect the control action. When a power failure of more than 20 ms occurs, the instrument assumes that the power has been turned off. When power returns, the controller will retain the conditions that existed prior to shut down.

The alarm hold action is activated when the power is turned on or the SV is changed, including an SV change made with the STEP function.

6.2 RUN/STOP

RUN/STOP can be selected by contact input (optional) other than the key operation. In addition, at STOP the key operation and contact state are displayed on the PV display. Relationships between key operation, RUN/STOP and the characters to indicate the STOP state are shown in the following.

		RUN/STOP with Contact Input ¹	
		RUN (Contact closed)	STOP (Contact open)
RUN/STOP with Key Operation	RUN	RUN STOP is not displayed	STOP dSTP (dSTP) ²
	STOP	STOP KSTP (KSTP) ²	STOP SToP (SToP) ²

¹ Contact input: Terminal No.10, 12

² Characters in parentheses are those shown on the PV display:

dSTP: Only contact input is in the STOP mode

KSTP: Only key operation is in the STOP mode

SToP: Both key operation and contact input are in the STOP mode

Conditions when changed to STOP mode:

- Control, Alarm: Control OFF, Alarm OFF
- Output: OUT1 output OFF (OPEN), OUT2 output OFF (OPEN)
- Autotuning (AT): AT canceled (The PID constants are not updated)

■ RUN/STOP transfer by key operation



1. Press and hold the <R/S key for 1 second in PV/SV display mode.
2. The mode is changed to STOP from RUN. The PV display shows the characters of showing the relevant STOP state.



Also when changing from STOP to RUN, press and hold the <R/S key for 1 second while in the PV/SV display mode.

■ RUN/STOP transfer by contact input

RUN/STOP can be selected according to the open or closed state of the terminal numbers 10 to 12.

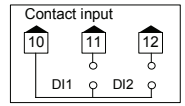

Terminal No.	RUN	STOP
10 - 12	Contact closed	Contact open

6.3 Set Data Lock (LCK)

The set data lock restricts parameter setting changes by key operation. This function prevents the operator from making errors during operation.

Set value	Parameters which can be changed
0000	All parameters [Factory set value]
0001	SV, Alarms (ALM1, ALM2)
0010	All parameters except for Alarms (ALM1, ALM2)
0100	All parameters except for SV
0011	SV
0101	Alarms (ALM1, ALM2)
0110	All parameters except for SV and Alarms (ALM1, ALM2)
0111	No parameters (All locked)



Set Data Lock can be changed in both RUN and STOP mode.



Parameters protected by Set Data Lock function are still displayed for monitoring.

6.4 Autotuning (AT)

Autotuning (AT) automatically measures, computes and sets the optimum PID and LBA constants. The following conditions are necessary to carry out AT and the conditions which will cause the AT to stop.



Caution for using the Autotuning (AT)

When a temperature change (UP and/or Down) is 1 °C or less per minute during AT, AT may not be finished normally. In that case, adjust the PID values manually. Manual setting of PID values may also be necessary if the set value is around the ambient temperature or is close to the maximum temperature achieved by the load.

■ Requirements for AT start

Start the AT when all following conditions are satisfied:

- Prior to starting the AT function, end all the parameter settings other than PID and LBA.
- Confirm the LCK function has not been engaged.



When the AT is finished, the controller will automatically returns to PID control.

■ Requirements for AT cancellation

The AT is canceled if any of the following conditions exist.

- When the Set value (SV1, SV2) is changed.
- When the power is turned off.
- When the PV bias value is changed.
- When the RUN/STOP mode is changed to the STOP mode.
- When the PV becomes abnormal due to burnout.
- When the AT does not end in 9 hours after autotuning started.
- When power failure longer than 20 ms occurs.



If the AT is canceled, the controller immediately changes to PID control. The PID values will be the same as before AT was activated.



When AT is completed, the controller immediately changes to PID control. If the control system does not allow the AT cycling process, set each PID constant manually to meet the needs of the application.

6.5 Self-tuning (ST)

The ST function is used to automatically calculate and set adaptive PID constants anytime the power is turned on, the SV is changed or the controller detects unstable control conditions.



The ST function should be turned off when the controlled system is affected by rippling that occurs due to periodic external disturbances.



The power to the controlled system must be turned on before the power to the instrument is turned on or SV is changed. This is required when ST function is on.



To activate the ST function, the following parameters must not be set to zero: P≠0, I≠0, D≠0, ARW≠0.



When Heat/Cool PID action is selected, the ST function cannot be activated.



When the AT function is activated, the ST function cannot be turned on.



When the ST function is activated, the PID and ARW settings can be monitored, but not changed.

7. FUNCTIONS

7.1 PV Bias

The value set in the PV bias is added to the input value (actual measured value) to correct the input value. The PV bias is used to correct the individual variations in the sensors or when there is difference between the Measured values (PV) of other instruments.

7.2 Digital Filter

This is a software filter which reduces input value variations caused by noise. If the time constant of this filter is set appropriately to match the characteristics of the controlled object and the noise level, the effects of input noise can be suppressed. However, if the time constant is too small, the filter may not be effective, while if the time constant is too large, then the input response may actually deteriorate.

7.3 STEP (Optional)

The instrument has two Set values (SV). This STEP function selects these two Set values (SV) by contact input (Terminal No.10, 11).

Contact open: Set value (SV1)
Contact closed: STEP set value (SV2)

7.4 Alarms



Both of the Alarm 1 and Alarm 2 outputs of this instrument are turned on when burnout occurs regardless of any of the following actions taken (high alarm, low alarm, etc.). In addition, when used for any purposes other than these alarms (event, etc.), set "0000" to the process abnormality action selection (AEo1, AEo2) of "8.7 Function Block 41 (F41), 42 (F42)."

Each alarm action is shown below.

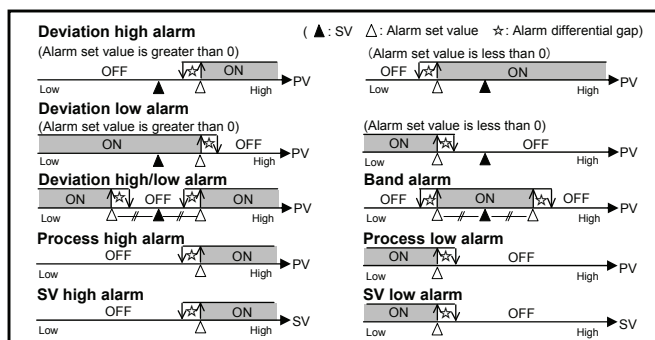

7.5 Control Loop Break Alarm (LBA)

The LBA function is used to detect a load (heater) break or a failure in the external actuator (power controller, magnet relay, etc.), or a failure in the control loop caused by an input (sensor) break.

The LBA function is activated when control output reaches 0 % or 100 %. LBA monitors variation of the Measured value (PV) for the length of LBA time. When the LBA time has elapsed and the PV is still within the alarm determination range, the LBA will be ON.

Precaution for LBA setting:

- Displayed only for when LBA is selected as Alarm 1.
- No control loop break alarm can be used at Heat/Cool PID control action.
- The LBA function cannot be activated when AT function is turned on.
- The LBA function is activated when control output reaches 0 % or 100 %. The time required for the LBA output to turn on includes both the time from the initial occurrence of loop failure and the LBA setting time. Recommended setting for LBA is for the set value of the LBA to be twice the value of the Integral time (I).
- If LBA setting time does not match the controlled object requirements, the LBA will malfunction by turning on or off at inappropriate times or not turning on at all.

■ LBA Deadband (LBD)

The LBA may malfunction due to external disturbances. To prevent malfunctioning due to external disturbance, LBA deadband (LBD) sets a neutral zone in which LBA is not activated. When the measured value (PV) is within the LBD area, LBA will not be activated. If the LBD setting is not correct, the LBA will not work correctly.

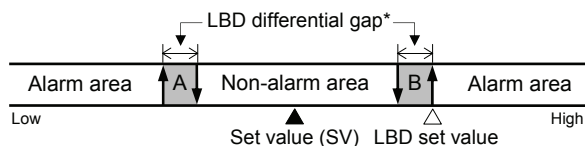

A: During temperature rise: Alarm area B: During temperature rise: Non-alarm area
 During temperature fall: Non-alarm area During temperature fall: Alarm area

* TC/RTD inputs: 0.8 °C [°F] (fixed)
 Voltage/Current inputs: 0.8 % of span (fixed)

8. INITIAL SETTING



WARNING

Parameters in the Engineering mode should be set according to the application before setting any parameter related to operation. Once the parameters in the Engineering mode are set correctly, no further changes need to be made to parameters for the same application under normal conditions. If they are changed unnecessarily, it may result in malfunction or failure of the instrument. RKC will not bear any responsibility for malfunction or failure as a result of improper changes in the Engineering mode.

8.1 Go to Engineering Mode

1. Turn on the power to this controller. The instrument goes to the PV/SV display after confirming input type symbol and input range.
2. Press and hold the SET key for 2 seconds to go to the Parameter setting mode from the PV/SV display.
3. Press the SET key until "LCK" (Set Data Lock display) will be displayed.
4. The blinking digit indicates which digit can be set. Press <R/S key to move to the thousands digit.
5. Press the UP key to change 0 to 1.

Set data lock function display

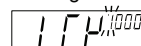

Set value
 0: Engineering mode locked
 1: Engineering mode unlocked

6. Press the SET key to store the new set value. The display goes to the next parameter, and the Engineering mode is unlocked.
7. Press and hold the SET key for 2 seconds to change to the PV/SV display mode.
8. Press and hold the <R/S key for 1 second to change the Operation mode from RUN mode to STOP mode.



Before the setting is changed in engineering mode, it is necessary to set the operation mode to the STOP mode.



The STOP message to be displayed varies depending on the specification.

9. Press and hold the <R/S key for 2 seconds while pressing the SET key to go to the Engineering Mode. Thus, the symbol "F10" for function block is displayed first.

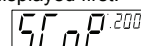

STOP mode display

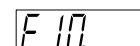

Function block symbol displayed engineering mode

8.2 Engineering Menu

Display flowcharts in engineering mode are shown in the following.



Do not change to the section parameters and any parameter in the Engineering mode which is not described in the Engineering menu below. It may result in malfunction or failure of the instrument.

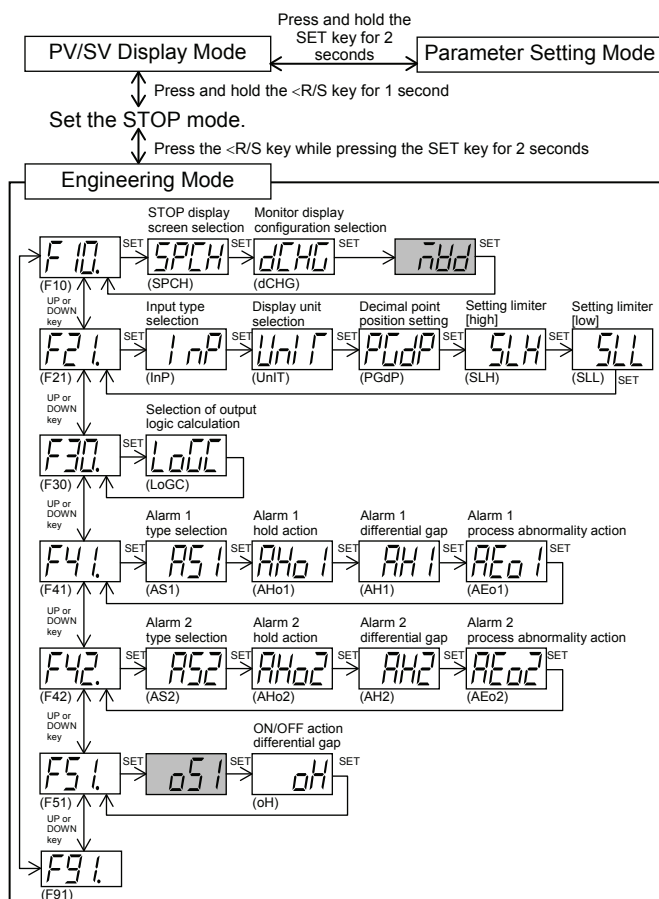

8.3 Attention Items in Setting

If any of the following settings are changed, the relevant set value is initialized or is automatically converted.

Before changing the set values, record all of them (SV setting mode, Parameter setting mode and Engineering mode).

After changing the set values, always check all of them (SV setting mode, Parameter setting mode and Engineering mode).

■ When the input type or engineering unit is changed

The set value is initialized.

Mode	Description	Default value	
		TC/RTD inputs	Voltage/Current inputs
Engineering mode	Decimal point position	0 (Without decimal point)	1
	Setting limiter high	Maximum settable value	100.0
	Setting limiter low	Minimum settable value	0.0
	Alarm 1 hold action selection	0 (Without alarm hold action)	
	Alarm 1 differential gap	2 °C [°F]	0.2 % of span
	Alarm 1 process abnormality action	Alarm 1 not provided or LBA: 0 (Normal) Alarm 1 provided: 1 (Forcibly turned on)	
	Alarm 2 hold action selection	0 (Without alarm hold action)	
	Alarm 2 differential gap	2 °C [°F]	0.2 % of span
	Alarm 2 process abnormality action	Alarm 2 not provided: 0 (Normal) Alarm 2 provided: 1 (Forcibly turned on)	
	ON/OFF action differential gap	2 °C [°F]	0.2 % of span
Parameter setting mode	Alarm 1 set value	50 °C [°F]	5.0 % of span
	Alarm 2 set value		
	Control loop break alarm (LBA)	8.0 minutes	
	LBA deadband (LBD)	0 °C [°F]	0.0
	Heat-side proportional band	30 °C [°F]	3.0 % of span
	Integral time	240 seconds	
	Derivative time	60 seconds	
	Anti-reset windup	100 %	
	Overlap/Deadband	0 °C [°F]	0.0
	Cool-side proportional band	100 %	
	PV bias	0 °C [°F]	0.0
	Digital filter	0 second (off)	
	PV/SV display mode, SV setting mode	Set value (SV)	STEP function not provided
Set value (SV1)		STEP function provided	0 °C [°F]
Set value (SV2)			0.0

■ When the setting limiter is changed

If the Setting limiter high (SLH) or Setting limiter low (SLL) is changed as follows, the related set values are changed. (Refer to below)

Only for TC/RTD inputs:

- If SLH is set to SLH < SLL, it is changed to SLH = SLL.
Example: If SLL is set to 200 with SLH set to 100, SLH is changed to 200.
- If SLL is set to SLH < SLL, it is changed to SLH = SLL.
Example: If SLH is set to 100 with SLL set to 200, SLL is changed to 100.

For TC/RTD inputs, Voltage/Current inputs:

If the setting is made so that the span becomes narrower, there may be a case where the related set value becomes smaller or 0.

Mode	Description
Engineering mode	Alarm 1 differential gap
	Alarm 2 differential gap
	ON/OFF action differential gap
Parameter setting mode	Alarm 1 set value
	Alarm 2 set value
	LBA deadband (LBD)
	Deadband
	Heat-side proportional band
	PV bias
PV/SV display mode, SV setting mode	Set value (SV) STEP function not provided
	Set value (SV1) STEP function provided
	Set value (SV2)

■ When the position of the decimal point is changed

The set value is automatically converted.

- After the position of the decimal point is changed, conduct automatic conversion so that the following values may not be changed.

Engineering mode:

Setting limiter high, Setting limiter low, Alarm 1 differential gap, Alarm 2 differential gap, ON/OFF action differential gap

Parameter setting mode:

Alarm 1 set value, Alarm 2 set value, LBA deadband (LBD), Heat-side proportional band, Overlap/Deadband, PV bias

PV/SV display/SV setting mode:

Set value (SV) [STEP function not provided], Set value (SV1), Set value (SV2) [STEP function provided]

Example: When the position of the decimal point changed from 0 to 1 with SLH set to 800 °C.
 → (Changed from 800 to 800.0.)

- If the setting range is not between -1999 and +9999 regardless of the position of the decimal point, it is limited by the range from -1999 to +9999.

Example: When SLH is 1372 °C with no decimal position, and the decimal position is changed from 0 to 1 (one decimal position), SLH will become 999.9.
 →

- If the number of digits below the decimal point is changed in the decreasing direction, the decreased number of digits is omitted.

Example: When SHL is 99.99 with two decimal positions, and the decimal position is changed from 2 to 0, SLH will become 99 by discarding the digits below the decimal point.
 →

■ When the type of alarm is changed

The set value is initialized.

Mode	Description	Default value	
		TC/RTD inputs	Voltage/Current inputs
Engineering mode	Alarm 1 hold action selection	0 (Without alarm hold action)	
	Alarm 1 differential gap	2 (2.0) °C [°F]	0.2 % of span
	Alarm 1 process abnormality action	Alarm 1 not provided or LBA: 0 (Normal) Alarm 1 provided: 1 (Forcibly turned on)	
	Alarm 2 hold action selection	0 (Without alarm hold action)	
	Alarm 2 differential gap	2 (2.0) °C [°F]	0.2 % of span
	Alarm 2 process abnormality action	Alarm 2 not provided: 0 (Normal) Alarm 2 provided: 1 (Forcibly turned on)	
Parameter setting mode	Alarm 1 set value	50 (50.0) °C [°F]	5.0 % of span
	Alarm 2 set value		

8.4 Function Block 10 (F10)

(1) STOP display screen selection (SPCH)

Set value	Description
0000	STOP is displayed on the PV display unit. (TYPE 1)
0001	STOP is displayed on the SV display unit. (TYPE 2)
0002	No selection from RUN to STOP by the front key can be made*.

* If Set value is set to 0002, no selection from RUN to STOP can be made, but selection from STOP to RUN can be made. In addition, RUN/STOP can be selected via communication or by contact input regardless of the SPCH setting.

Displays in the STOP mode display become as follows.

TYPE1 (SPCH=0000)			
TYPE2 (SPCH=0001)			

● Change Settings

Example: Change the STOP display from TYPE 1 to TYPE 2

- Change the instrument to the function block symbol display F10.
- Refer to 8.1 Go to Engineering Mode (P. 5).
- Press the SET key to change to SPCH (STOP display). Then, press the UP key to enter 1 in the units digit of the Set value (SV) display.
- Press the SET key to store the new set value. The display goes to the next parameter.

(2) Monitor display configuration selection (dCHG)

Set value	Description	Set value	Description
0000	PV/SV display	0002	Only SV display
0001	Only PV display	—	—

Displays become as follows.

PV/SV display (dCHG = 0000)			
Only PV display (dCHG = 0001)			
Only SV display (dCHG = 0002)			

● Change Settings

Example: Change the monitor display configuration selection from PV/SV display to Only PV display

- Press the SET key at F10 until dCHG (Monitor display configuration selection) is displayed.
- Press the UP key to change the number to 0.
- Press the SET key to store the new set value. The display goes to the next parameter.

8.5 Function Block 21 (F21)

(1) Input type selection (InP)

Factory set value varies depending on the input type.

Set value	Input type	Set value	Input type
0000	K	0010	U
0001	J	0011	L
0002	R	0012	Pt100 (JIS/IEC)
0003	S	0013	JPt100 (JIS)
0004	B	0014	0 to 5 V DC
0005	E	0015	1 to 5 V DC
0006	N	0016	0 to 10 V DC
0007	T	0014	0 to 20 mA DC
0008	W5Re/W26Re	0015	4 to 20 mA DC
0009	PL II		

¹ Input type (TC/RTD to Voltage/Current inputs or Voltage/Current inputs to TC/RTD) cannot be changed because the hardware is different.

² For the current input specification, an external resistor of 250 Ω must be connected between the input terminals.

● Change Settings

Example: Change the Input type from K to J

1. Change the instrument to the function block symbol display.
2. As InP belongs to the F21, press the UP key to change the display from F10 to F21.
3. Press the SET key to change to InP. Then, press the UP key to enter 1 in the units digit of the Set value (SV) display.
4. Press the SET key to store the new set value. The display goes to the next parameter.

(2) Display unit selection (UnIT)

Invalid in case of the Voltage/Current inputs.

Refer to 8.3 Attention Items in Setting (P. 6).

Factory set value: 0000

Set value	Description	Set value	Description
0000	°C	0001	°F

● Change Settings

Example: Change the temperature unit of the Heat only type from “°C (0000)” to “°F (0001)”

1. Press the SET key several times at “F21” until “UnIT” is displayed.
2. Press the UP key to change the number to 1.
3. Press the SET key to store the new set value. The display goes to the next parameter.

(3) Decimal point position (PGdP)

Factory set value varies depending on the instrument specification.

Set value	Description	Set value	Description
0000	No decimal place (□□□□)	0002	Two decimal places (□□.□□)
0001	One decimal place (□□□.□)	0003	Three decimal places (□.□□□)

● Change Settings

Example: Change the decimal point position from “One decimal place (0001)” to “No decimal place (0000)”

1. Press the SET key several times at F21 until PGdP is displayed.
2. Press the DOWN key to change the number to 0.
3. Press the SET key to store the new set value. The display goes to the next parameter.

(4) Setting limiter high (SLH), Setting limiter low (SLL)

Set the setting limiter referring to the Input Range Table (P. 8).

Refer to 8.3 Attention Items in Setting (P. 6).

Factory set value varies depending on the instrument specification.

Input type	Setting range		
TC	K	-199 to +1372 °C (-326 to +2502 °F) -199.9 to +999.9 °C (-199.9 to +999.9 °F)	
	J	-199 to +1200 °C (-326 to +2192 °F) -199.9 to +999.9 °C (-199.9 to +999.9 °F)	
	R	0 to 1769 °C (0 to 3216 °F)	
	S	0 to 1769 °C (0 to 3216 °F)	
	B	0 to 1820 °C (0 to 3308 °F)	
	E	0 to 1000 °C (0 to 1832 °F)	
	N	0 to 1300 °C (0 to 2372 °F) 0.0 to 999.9 °C (0 to 999.9 °F)	
	T	-199 to +400 °C (-326 to +752 °F) -199.9 to +400.0 °C (-199.9 to +752.0 °F)	
	W5Re/W26Re	0 to 2320 °C (0 to 4208 °F)	
	PL II	0 to 1390 °C (0 to 2534 °F)	
	U	-199 to +600 °C (-326 to +1112 °F) -199.9 to +600.0 °C (-199.9 to +999.9 °F)	
	L	0 to 900 °C (0 to 1652 °F)	
	RTD	Pt100 (JIS/IEC) ¹ JPH100 (JIS)	-199.9 to +649.0 °C (-199.9 to +999.9 °F)
		0 to 5 V DC 1 to 5 V DC 0 to 10 V DC	-1999 to +9999 (programmable scale)
Current ^{2,3}	0 to 20 mA DC 4 to 20 mA DC	-1999 to +9999 (programmable scale)	

¹ IEC (International Electrotechnical Commission) is equivalent to JIS, DIN and ANSI.

² In case of Voltage/Current inputs, SLH can be set below SLL.

³ For the current input specification, an external resistor of 250 Ω must be connected between the input terminals.

● Change Settings

Example: When the display range is scaled to 0.0 to 400.0 for a voltage input of 1 to 5 V DC.

Factory set value	→ 0.0	100.0
Scaling	→ 0.0	400.0

1. Set F21, and press the SET key. The display will go to SLH.
2. The blinking digit indicates which digit can be set. Press the <R/S key to move to the thousands digit.
3. Press the UP key to change the number to 4.
4. Press the SET key to store the new set value. The display goes to SLL. For the SLL (Setting limiter low), check that the display is set to 0.0.

The input range high and low of this instrument are set with SLH and SLL.

Changing SLH and SLL will change the input range high and low to the same value accordingly. The change of the input range will then change the over-scale and underscale flashing range.

8.6 Function Block 30 (F30)

■ Output logic operation selection (LoGC)



Match the setting with the instrument specification. Otherwise malfunction may result.

No heat-side or cool-side proportional cycle (T or t) corresponding to a Parameter setting mode made may not be displayed depending on the selected output allocation code.

- Not displayed when no control output is selected.
- Not displayed when control output corresponds to current output.

Factory set value varies depending on the instrument specification.

Set value	OUT1	OUT2	Remarks
001	Control output	OR output of alarm 1 and alarm 2 (Energized)	PID action + No alarm function * PID action + Alarm 1 * PID action + OR output of Alarm 1, alarm 2 *
002	Heat-side control output	Cool-side control output (In case of direct action or reverse action, it is OFF).	Heat/cool PID action * (W or A type)
003	Control output	Alarm 1 output (De-energized)	PID action + Alarm 1
004	Control output	AND output of alarm 1 and alarm 2 (Energized)	PID action + Alarm 1, alarm 2
005	Control output	OR output of alarm 1 and alarm 2 (De-energized)	PID action + Alarm 1, alarm 2
006	Control output	AND output of alarm 1 and alarm 2 (De-energized)	
007	Control output	No output (The alarm state can be checked via communication or by lamp lighting).	PID action + Alarm 1, alarm 2 or alarm1 only
008	Control output	Alarm 1 output (Energized) (Alarm 2 can be checked via communication or by lamp lighting).	PID action + Alarm 1, alarm 2
009	Alarm 1 output (Energized)	Alarm 2 output (Energized)	Alarm 1 + Alarm 2 (The PID operation can choose only F type.)
010	Alarm 1 output (Energized)	Alarm 2 output (De-energized)	
011	Alarm 1 output (De-energized)	Alarm 2 output (De-energized)	

* Standard output when no output code is specified.

8.7 Function Block 41 (F41), 42 (F42)

(1) Alarm 1 type selection (AS1)

Alarm 2 type selection (AS2)



Refer to 8.3 Attention Items in Setting (P. 6).

Factory set value varies depending on the instrument specification.

Set value	Description	Set value	Description
0000	Alarm not provided	0005	Deviation high alarm
0001	SV high alarm	0006	Deviation low alarm
0002	SV low alarm	0007	Deviation high/low alarm
0003	Process high alarm	0008	Band alarm
0004	Process low alarm	0009	Control loop break alarm (LBA)*

* Available only with Alarm 1 type

● Change Settings

Example: Change the Alarm 1 type from “Deviation high alarm (0005)” to “Deviation low alarm (0006)”

1. Press the SET key at F41 until AS1 is displayed.
2. Press the UP key to change the number to 6.
3. Press the SET key to store the new set value. The display goes to the next parameter.

(2) Alarm 1 hold action selection (AHO1)

Alarm 2 hold action selection (AHO2)



The alarm hold action function cannot be added to the SV alarm.

Refer to 8.3 Attention Items in Setting (P. 6).

Factory set value varies depending on the instrument specification.

Set value	Description
0000	Without alarm hold action
0001	Effective when the power is turned on, or operation is changed from STOP to RUN.
0002	Effective when the power is turned on, or operation is changed from STOP to RUN or the SV is changed.

● Change Settings

Example: Change the Alarm 1 hold action selection from “Without alarm hold action (0000)” to “Effective when the power is turned on, or operation is changed from STOP to RUN (0001)”

1. Press the SET key at F41 until AHO1 is displayed.
2. Press the UP key to change the number to 1.
3. Press the SET key to store the new set value. The display goes to the next parameter.

(3) Alarm 1 differential gap (AH1)

Alarm 2 differential gap (AH2)

Setting range: TC/RTD inputs, Voltage/Current inputs: 0 (0.0) to span

Factory set value: TC/RTD inputs: 2 °C [°F] or 2.0 °C [°F]

Voltage/Current inputs: 0.2 % of span

● Change Settings

Example: Change the Alarm 1 differential gap from 2 °C to 4 °C

1. Press the SET key at F41 until AH1 is displayed.
2. Press the UP key to change the number to 4.
3. Press the SET key to store the new set value. The display goes to the next parameter.

(4) Alarm 1 process abnormality action selection (AEo1) Alarm 2 process abnormality action selection (AEo2)



It is judged that the input is abnormal when over-scale or underscale occurs.

Set value	Description
0000	Normal processing: The alarm action set by AS1 (Alarm 1 type selection) or AS2 (Alarm 2 type selection) is taken even if the input is abnormal.
0001	Forcibly turned on when abnormal: The alarm is forcibly turned on regardless of the alarm type set by AS1 or AS2 when the input is abnormal. However, for a voltage input of 0 to 5 V DC or 0 to 10 V DC, or a current input of 0 to 20 mA DC, as over-scale or underscale does not occur when the input breaks, no alarm is turned on.

Factory set value:

- Alarm 1 not provided or LBA: 0 (Normal processing)
- Alarm 1 provided: 1 (Forcibly turned on when abnormal)
- Alarm 2 not provided: 0 (Normal processing)
- Alarm 2 provided: 1 (Forcibly turned on when abnormal)

● Change Settings

Example: Change the Alarm 1 process abnormality action selection from "Normal processing (0000)" to "Forcibly turned on when abnormal (0001)"

- Press the SET key at F41 until AEo1 is displayed.
- Press the UP key to change the number to 1.
- Press the SET key to store the new set value. The display goes to the function block symbol (F41).

8.8 Function Block 51 (F51)



Do not change oS1. Otherwise, it will cause malfunction.

■ ON/OFF Action differential gap (oH)

Setting range: TC/RTD inputs, Voltage/Current inputs: 0 (0.0) to span

Factory set value: TC/RTD inputs: 2 °C [°F] or 2.0 °C [°F]
Voltage/Current inputs: 0.2 % of span

● Change Settings

Example: Change the ON/OFF action differential gap from 2 °C to 4 °C

- Press the SET key at F51 until oH is displayed.
- Press the UP key to change the number to 4.
- Press the SET key to store the new set value. The display goes to the function block symbol (F51).

8.9 Exit Engineering Mode

- Transfer to function block symbol display (F□□) after each parameter is set.
- Press and hold the <R/S key for 2 seconds while pressing the SET key from any display in the Engineering Mode.
- Press and hold the SET key for 2 seconds in the PV/SV display.
- Press the SET key until LCK (Set Data Lock display) will be displayed.
- The blinking digit indicates which digit can be set. Press the <R/S key to move to the thousands digit.
- Press the DOWN key to change 1 to 0.

Set data lock function display

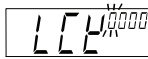

9. ERROR DISPLAYS

■ Self-diagnostic error

Error No.	Description	Operation at error	Solution
1	Adjustment data error	Display:	Turn off the power at once. If an error occurs after the power is turned on again, please contact RKC sales office or the agent.
2	EEPROM error	Error display (Err)	
4	A/D conversion error	Control output:	
8	RAM check error	All output is OFF	
128	Watchdog timer error	Alarm output: All output is OFF	

Example: When the adjustment data error and A/D conversion error occurs simultaneously

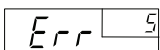

The error codes are shown in the SV display. When two or more errors occur simultaneously, the total summation of these error codes is displayed.

■ Over-scale and Underscale

Display	Description	Solution
Measured value (PV) [Flashing]	Measured value (PV) is outside of input range.	WARNING To prevent electric shock, always turn off the power before replacing the sensor.
oooo flashing	Over-scale: Measured value (PV) is above the high input display range limit.	
uuuu flashing	Underscale: Measured value (PV) is below the low input display range limit.	Check Input type, Input range and connecting state of sensor. Confirm that the sensor or wire is not broken.

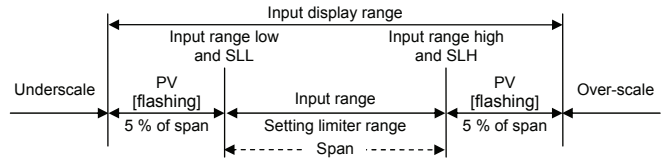

10. INPUT RANGE TABLE

●TC/RTD						
Type	Range	Code	Range	Code	Range	Code
K	0 to 200 °C	01	0 to 400 °C	02	0 to 600 °C	03
	0 to 800 °C	04	0 to 1000 °C	05	0 to 1200 °C	06
	0 to 1372 °C	07	-199.9 to +300.0 °C	08	0 to 400.0 °C	09
	0.0 to 800.0 °C	10	0 to 100 °C	13	0 to 300 °C	14
	0 to 450 °C	17	0 to 500 °C	20	0 to 200.0 °C	29
	0.0 to 600.0 °C	37	-199.9 to +800.0 °C	38	0 to 800 °F	A1
	0 to 1600 °F	A2	0 to 2502 °F	A3	0.0 to 800.0 °F	A4
	20 to 70 °F	A9	-199.9 to +999.9 °F	B2		
				B3		
				B6		
J	0 to 200 °C	01	0 to 400 °C	02	0 to 600 °C	03
	0 to 800 °C	04	0 to 1000 °C	05	0 to 1200 °C	06
	-199.9 to +300.0 °C	07	0 to 400.0 °C	08	0 to 800.0 °C	09
	0 to 450 °C	10	0 to 200.0 °C	22	0 to 600.0 °C	23
	-199.9 to +800.0 °C	37	0 to 800 °F	A1	0 to 1600 °F	A2
	0 to 2192 °F	A3	0 to 400 °F	A6	-199.9 to +999.9 °F	A9
	0.0 to 800.0 °F	B6				
R	0 to 1600 °C *1	R 01	0 to 1769 °C *1	R 02	0 to 1350 °C *1	R 04
	0 to 3200 °F *1	A1	0 to 3216 °F *1	A2		
S	0 to 1600 °C *1	S 01	0 to 1769 °C *1	S 02		
	0 to 3200 °F *1	A1	0 to 3216 °F *1	A2		
B	400 to 1800 °C	B 01	0 to 1820 °C *1	B 02		
	800 to 3200 °F	A1	0 to 3308 °F *1	A2		
E	0 to 800 °C	E 01	0 to 1000 °C	E 02		
	0 to 1600 °F	A1	0 to 1832 °F	A2		
N	0 to 1200 °C	N 01	0 to 1300 °C	N 02	0 to 800.0 °C	N 06
	0 to 2300 °F	A1	0 to 2372 °F	A2	0 to 999.9 °F	N A5
T	-199.9 to +400.0 °C *2	T 01	-199.9 to +100.0 °C *2	T 02	-100.0 to +200.0 °C	T 03
	0.0 to 350.0 °C	04	-199.9 to +752.0 °F *2	A1	-100.0 to +200.0 °F	T A2
	-100.0 to +400.0 °F	A3	0.0 to 450.0 °F	A4	0.0 to 752.0 °F	A5
W5Re/W26Re	0 to 2000 °C	W 01	0 to 2320 °C	W 02	0 to 4000 °F	W A1
	0 to 1300 °C	A 01	0 to 1390 °C	A 02	0 to 1200 °C	A 03
PL11	0 to 2400 °F	A 01	0 to 2534 °F	A 02		
U	-199.9 to +600.0 °C *2	U 01	-199.9 to +100.0 °C *2	U 02	0.0 to 400.0 °C	U 03
	-199.9 to +999.9 °F *2	A1	-100.0 to +200.0 °F	A2	0.0 to 999.9 °F	U A3
L	0 to 400 °C	L 01	0 to 800 °C	L 02		
	0 to 800 °F	A1	0 to 1600 °F	A2		
Pt100	-199.9 to +649.0 °C	01	-199.9 to -200.0 °C	02	-100.0 to +50.0 °C	03
	-100.0 to +100.0 °C	04	-100.0 to +200.0 °C	05	0.0 to +50.0 °C	06
	0.0 to 100.0 °C	07	0.0 to 200.0 °C	08	0.0 to 300.0 °C	09
	0.0 to 500.0 °C	10				
	-199.9 to +999.9 °F	A1	-199.9 to +400.0 °F	A2	-199.9 to +200.0 °F	A3
	-199.9 to +100.0 °F	A4	0.0 to 200.0 °F	A5	0.0 to 100.0 °F	A6
	0.0 to 200.0 °F	A7	0.0 to 400.0 °F	A8	0.0 to 500.0 °F	A9
JPl100	-199.9 to +649.0 °C	01	-199.9 to -200.0 °C	02	-100.0 to +50.0 °C	03
	-100.0 to +100.0 °C	04	-100.0 to +200.0 °C	05	0.0 to +50.0 °C	06
	0.0 to 100.0 °C	07	0.0 to 200.0 °C	08	0.0 to 300.0 °C	09
	0.0 to 500.0 °C	10				

*1 Accuracy is not guaranteed between 0 to 399 °C (0 to 751 °F) for type R, S and B.
*2 Accuracy is not guaranteed less than -100.0 °C (-148.0 °F) for type T and U.

●Voltage/current inputs

Type	Range	Code	Type	Range	Code
0 to 5 V DC	0.0 to 100.0 %	4 01	0 to 20 mA DC	0.0 to 100.0 %	7 01
0 to 10 V DC	0.0 to 100.0 %	5 01	4 to 20 mA DC	0.0 to 100.0 %	8 01
1 to 5 V DC	0.0 to 100.0 %	6 01			

11. REMOVING THE INTERNAL ASSEMBLY

Usually, this instrument is not necessary to remove the internal assembly from the case. When removing the internal assembly without disconnecting the external wiring, take the following steps.



WARNING

- To prevent electric shock or instrument failure, only qualified personnel should be allowed to pull out the internal assembly.
- To prevent electrical shock or instrument failure, always turn off the power before pulling out the internal assembly.
- To prevent injury or instrument failure, do not touch the internal printed wiring board.



Apply pressure very carefully when removing internal assembly to avoid damage to the frame.



To conform to IEC61010-1 requirements for protection from electric shock, the internal assembly of this instrument can only be removed with an appropriate tool.

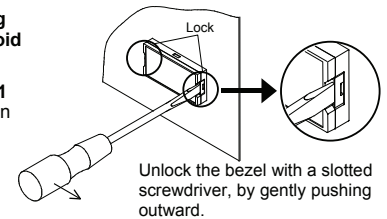

Recommended tool: Slotted screwdriver (Tip width: 3 mm or less)

The first edition: NOV. 1999
The seventh edition: AUG. 2013 [IMQ00]