

---

---

---

---

---

---

*Temperature Controller*

***SA201***

***Communication  
Instruction Manual***

- Modbus is a registered trademark of Schneider Electric.
- Company names and product names used in this manual are the trademarks or registered trademarks of the respective companies.

Thank you for purchasing the RKC instrument. In order to achieve maximum performance and ensure proper operation of your new instrument, carefully read all the instructions in this manual. Please place this manual in a convenient location for easy reference.

## SYMBOLS

**WARNING** : This mark indicates precautions that must be taken if there is danger of electric shock, fire, etc., which could result in loss of life or injury.

**CAUTION** : This mark indicates that if these precautions and operating procedures are not taken, damage to the instrument may result.



: This mark indicates that all precautions should be taken for safe usage.



: This mark indicates important information on installation, handling and operating procedures.



: This mark indicates supplemental information on installation, handling and operating procedures.



: This mark indicates where additional information may be located.



### WARNING

- An external protection device must be installed if failure of this instrument could result in damage to the instrument, equipment or injury to personnel.
- All wiring must be completed before power is turned on to prevent electric shock, fire or damage to instrument and equipment.
- This instrument must be used in accordance with the specifications to prevent fire or damage to instrument and equipment.
- This instrument is not intended for use in locations subject to flammable or explosive gases.
- Do not touch high-voltage connections such as power supply terminals, etc. to avoid electric shock.
- RKC is not responsible if this instrument is repaired, modified or disassembled by other than factory-approved personnel. Malfunction can occur and warranty is void under these conditions.

## **CAUTION**

- This is a Class A instrument. In a domestic environment, this instrument may cause radio interference, in which case the user may be required to take adequate measures.
- This instrument is protected from electric shock by reinforced insulation. Provide reinforced insulation between the wire for the input signal and the wires for instrument power supply, source of power and loads.
- Be sure to provide an appropriate surge control circuit respectively for the following:
  - If input/output or signal lines within the building are longer than 30 meters.
  - If input/output or signal lines leave the building, regardless the length.
- This instrument is designed for installation in an enclosed instrumentation panel. All high-voltage connections such as power supply terminals must be enclosed in the instrumentation panel to avoid electric shock by operating personnel.
- All precautions described in this manual should be taken to avoid damage to the instrument or equipment.
- All wiring must be in accordance with local codes and regulations.
- All wiring must be completed before power is turned on to prevent electric shock, instrument failure, or incorrect action.

The power must be turned off before repairing work for input break and output failure including replacement of sensor, contactor or SSR, and all wiring must be completed before power is turned on again.
- To prevent instrument damage or failure, protect the power line and the input/output lines from high currents with a protection device such as fuse, circuit breaker, etc.
- Prevent metal fragments or lead wire scraps from falling inside instrument case to avoid electric shock, fire or malfunction.
- Tighten each terminal screw to the specified torque found in the manual to avoid electric shock, fire or malfunction.
- For proper operation of this instrument, provide adequate ventilation for heat dispensation.
- Do not connect wires to unused terminals as this will interfere with proper operation of the instrument.
- Turn off the power supply before cleaning the instrument.
- Do not use a volatile solvent such as paint thinner to clean the instrument. Deformation or discoloration will occur. Use a soft, dry cloth to remove stains from the instrument.
- To avoid damage to instrument display, do not rub with an abrasive material or push front panel with a hard object.
- Do not connect modular connectors to telephone line.

## **NOTICE**

- This manual assumes that the reader has a fundamental knowledge of the principles of electricity, process control, computer technology and communications.
- The figures, diagrams and numeric values used in this manual are only for purpose of illustration.
- RKC is not responsible for any damage or injury that is caused as a result of using this instrument, instrument failure or indirect damage.
- Periodic maintenance is required for safe and proper operation of this instrument. Some components have a limited service life, or characteristics that change over time.
- Every effort has been made to ensure accuracy of all information contained herein. RKC makes no warranty expressed or implied, with respect to the accuracy of the information. The information in this manual is subject to change without prior notice.
- No portion of this document may be reprinted, modified, copied, transmitted, digitized, stored, processed or retrieved through any mechanical, electronic, optical or other means without prior written approval from RKC.

# CONTENTS

---

	Page
<b>1. OUTLINE .....</b>	<b>1</b>
<b>2. SPECIFICATIONS .....</b>	<b>2</b>
<b>3. WIRING .....</b>	<b>4</b>
<b>4. SETTING .....</b>	<b>6</b>
4.1 Transfer to Communication Setting Mode .....	6
4.2 Setting the Communication Parameters .....	7
4.3 Communication Requirements .....	11
<b>5. RKC COMMUNICATION PROTOCOL .....</b>	<b>13</b>
5.1 Polling .....	13
5.1.1 Polling procedures .....	14
5.1.2 Polling procedure example .....	17
5.2 Selecting .....	18
5.2.1 Selecting procedures .....	18
5.2.2 Selecting procedure example .....	21
5.3 Communication Identifier List .....	22
<b>6. MODBUS COMMUNICATION PROTOCOL .....</b>	<b>26</b>
6.1 Message Format .....	26
6.2 Function Code .....	27
6.3 Communication Mode .....	27
6.4 Slave Response .....	28
6.5 Calculating CRC-16 .....	29
6.6 Message Format .....	31
6.6.1 Reading holding registers [03H] .....	31
6.6.2 Preset single register [06H] .....	32
6.6.3 Diagnostics (loopback test) [08H] .....	33

---

	Page
6.7 Data Configuration.....	34
6.7.1 Data range.....	34
6.7.2 Data processing precautions .....	35
6.8 Communication Data List.....	36
<b>7. INPUT RANGE TABLES.....</b>	<b>40</b>
<b>8. TROUBLESHOOTING .....</b>	<b>44</b>
<b>9. ASCII 7-BIT CODE TABLE (REFERENCE).....</b>	<b>47</b>

# 1. OUTLINE

---

Temperature controller SA201 interfaces with the host computer via Modbus or RKC communication protocols. For reference purposes, the Modbus protocol identifies the host computer as master, the SA201 as slave.

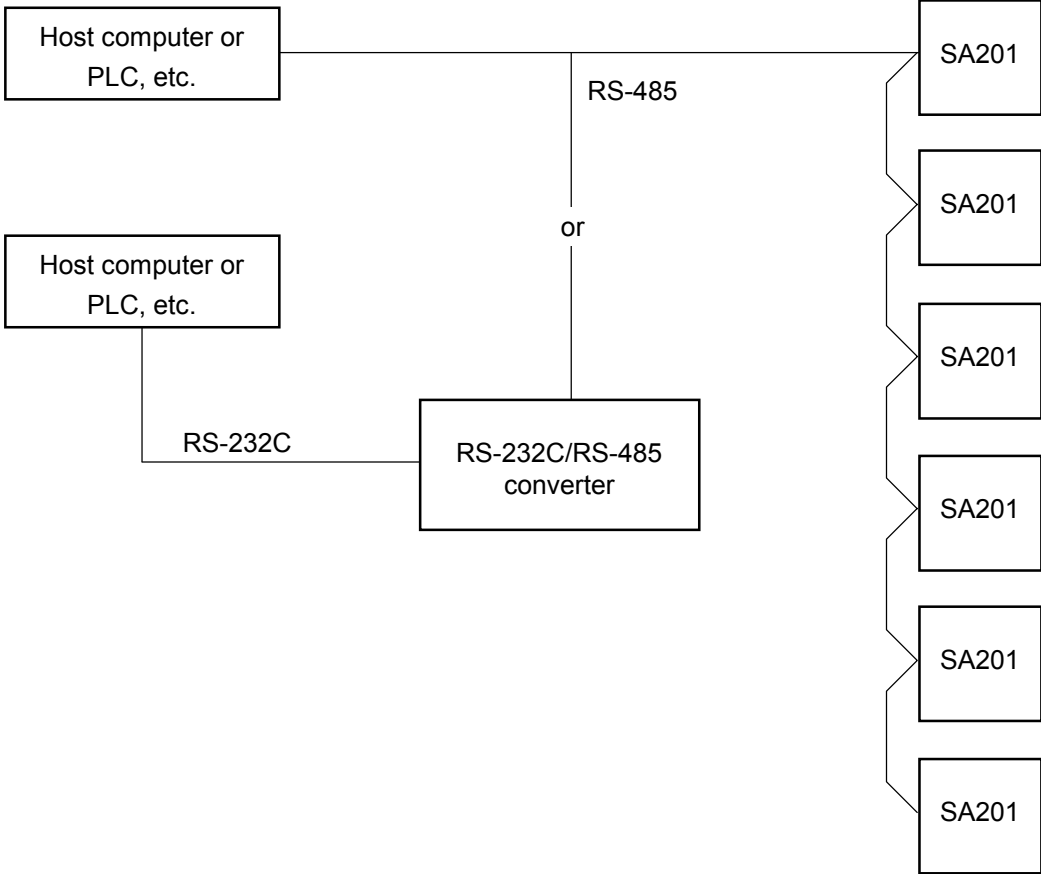

## 2. SPECIFICATIONS

---

### ■ RKC communication

<b>Interface:</b>	Based on RS-485, EIA standard
<b>Connection method:</b>	2-wire system, half-duplex multi-drop connection
<b>Communication distance:</b>	1 km max. The maximum communication distance will be affected by the surrounding conditions.
<b>Synchronous method:</b>	Start/stop synchronous type
<b>Communication speed:</b>	2400 bps, 4800 bps, 9600 bps, 19200 bps
<b>Data bit configuration:</b>	Start bit: 1 Data bit: 7 or 8 Parity bit: Without, Odd or Even Stop bit: 1 or 2
<b>Protocol:</b>	ANSI X3.28 subcategory 2.5, A4 Polling/selecting type
<b>Error control:</b>	Vertical parity (With parity bit selected) Horizontal parity (BCC check)
<b>Communication code:</b>	ASCII 7-bit code
<b>Termination resistor:</b>	Externally connected
<b>Xon/Xoff control:</b>	None
<b>Maximum connections:</b>	32 instruments maximum including a host computer
<b>Signal logic:</b>	RS-485

Signal voltage	Logic
$V(A) - V(B) \geq 2\text{ V}$	0 (SPACE)
$V(A) - V(B) \leq -2\text{ V}$	1 (MARK)

Voltage between V (A) and V (B) is the voltage of (A) terminal for the (B) terminal.



## ■ Modbus

<b>Interface:</b>	Based on RS-485, EIA standard
<b>Connection method:</b>	2-wire system, half-duplex multi-drop connection
<b>Communication distance:</b>	1 km max. The maximum communication distance will be affected by the surrounding conditions.
<b>Synchronous method:</b>	Start/stop synchronous type
<b>Communication speed:</b>	2400 bps, 4800 bps, 9600 bps, 19200 bps
<b>Data bit configuration:</b>	Data bit: 8 (Byte data corresponding to binary data or bit.) Parity bit: Without, Odd or Even Stop bit: 1
<b>Protocol:</b>	Modbus
<b>Signal transmission mode:</b>	Remote Terminal Unit (RTU) mode
<b>Function code:</b>	03H (Read holding registers) 06H (Preset single register) 08H (Diagnostics: loopback test)
<b>Error check method:</b>	CRC-16
<b>Error code:</b>	1: Function code error 2: When written to read only (RO) data, When any address other than 0000H to 001AH is specified, etc. 3: When the data written exceeds the setting range, When the specified number of data items in the query message exceeds the maximum number of data items available 4: Self-diagnostic error response
<b>Termination resistor:</b>	Externally connected
<b>Maximum connections:</b>	32 instruments maximum including a master
<b>Signal logic:</b>	RS-485

Signal voltage	Logic
$V(A) - V(B) \geq 2\text{ V}$	0 (SPACE)
$V(A) - V(B) \leq -2\text{ V}$	1 (MARK)

Voltage between V (A) and V (B) is the voltage of (A) terminal for the (B) terminal.

# 3. WIRING



## WARNING

To prevent electric shock or instrument failure, do not turn on the power until all the wiring is completed.

### ■ Terminal number and signal details

Terminal No.	Signal name	Symbol
10	Signal ground	SG
11	Send data/Receive data	T/R (A)
12	Send data/Receive data	T/R (B)

### ■ Wiring method

#### ● Connection to the RS-485 port of the host computer (master)

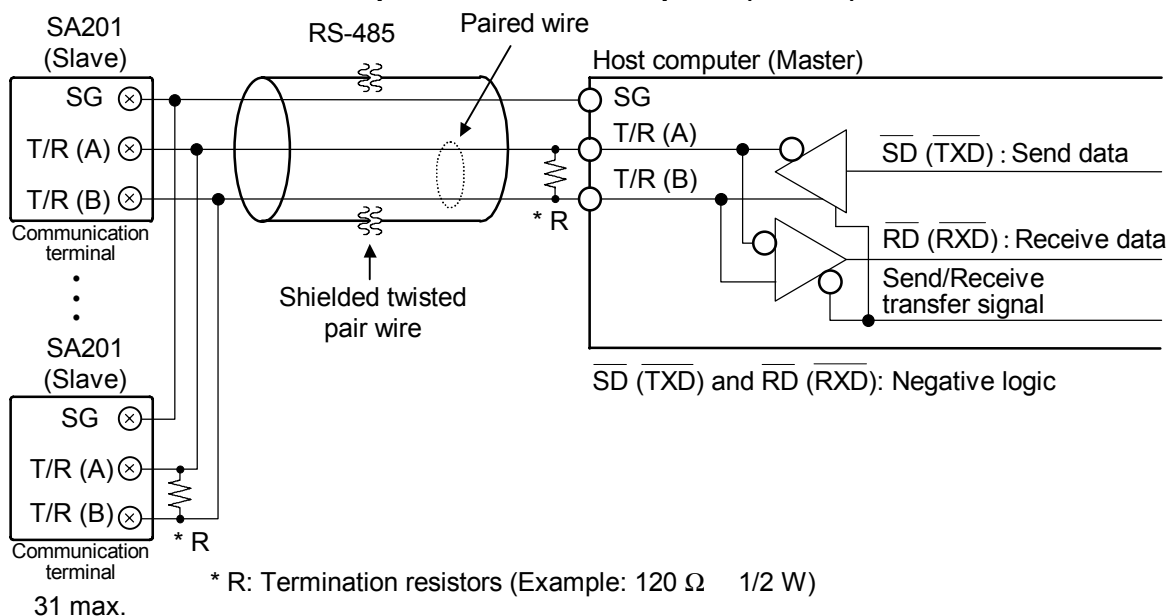

■ **Connection to the RS-232C port of the host computer (master)**

A RS-232C/RS-485 converter is required.

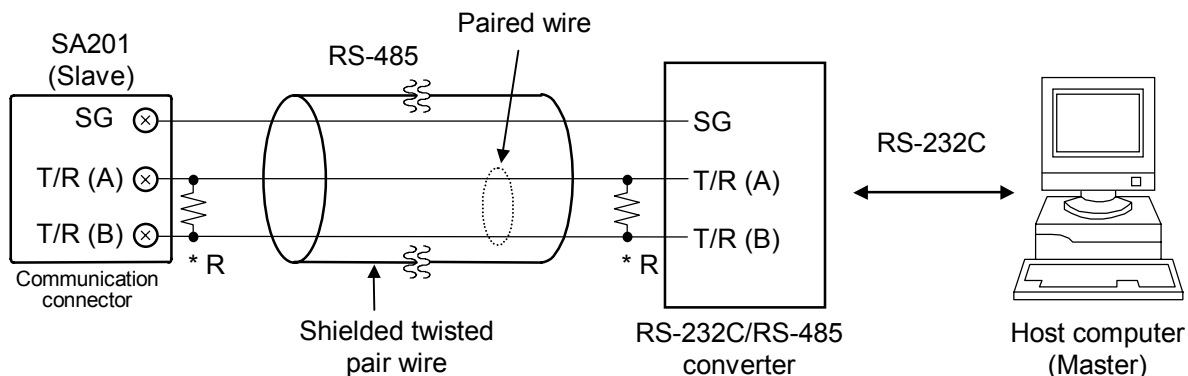

\* R: Termination resistors (Example: 120 Ω 1/2 W)

When the host computer (master) uses **Windows 95/98/NT**, use a RS-232C/RS-485 converter with an automatic send/receive transfer function.

Recommended: **CD485**, **CD485/V** manufactured by Data Link, Inc. or equivalent.

The cable is provided by the customer.

■ **Connection with up to 31 SA201 (slaves) and one host computer (master)**

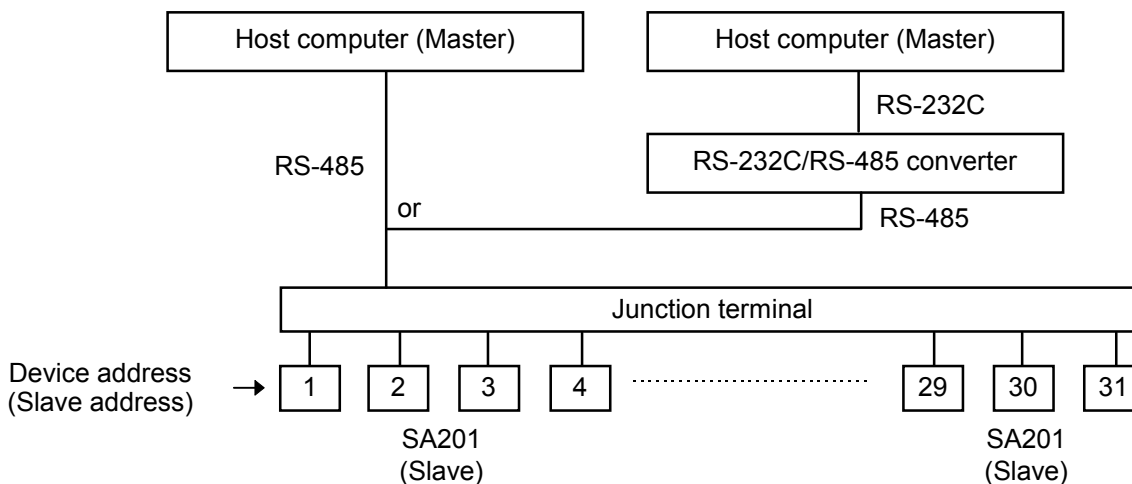

# 4. SETTING

To establish communication parameters between host computer (master) and SA201 (slave), it is necessary to set the device address (slave address), communication speed, data bit configuration and interval time on each SA201 (slave) in the communication mode.

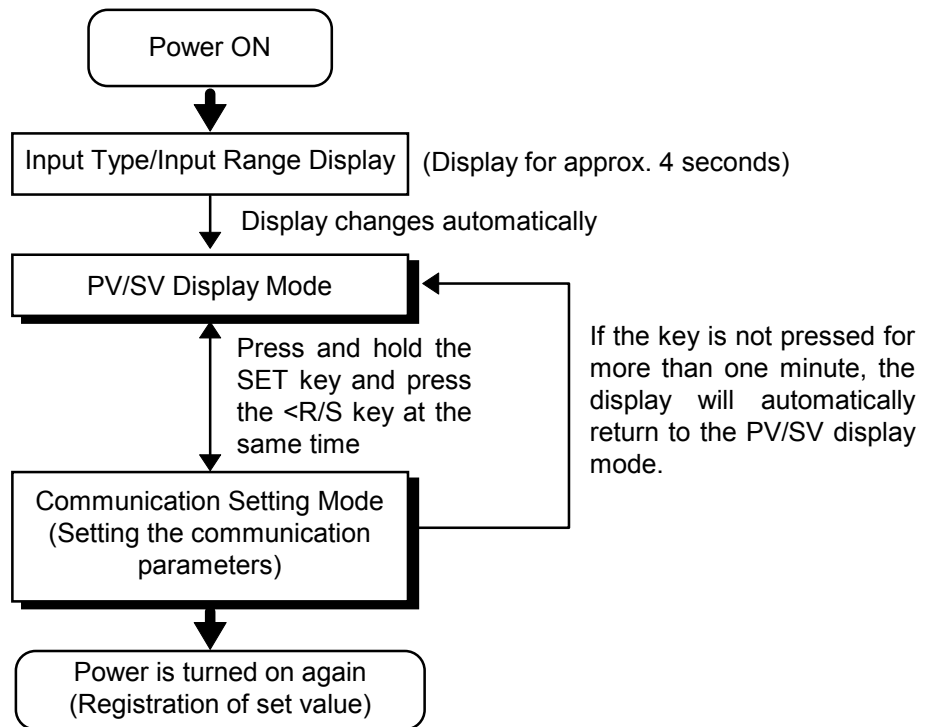

## 4.1 Transfer to Communication Setting Mode

To go to the communication setting mode, you must be in PV/SV display. Press and hold the SET key and press the <R/S key at the same time to initiate communication settings. The first parameter to be displayed will be the device address (slave address), *Add*.

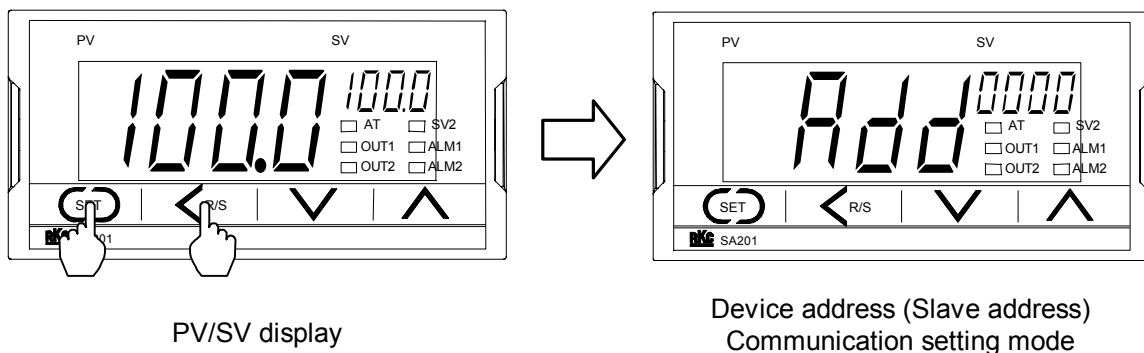

When let communication setting mode finish, press and hold the SET key and press the <R/S key at the same time. The display changes to the PV/SV display.

## 4.2 Setting the Communication Parameters

To select parameters in communication setting mode, press the SET key. The parameters are displayed and sequenced in the order of device address (slave address), *Add*, communication speed, *bPS*, data bit configuration, *bit* and interval time set value, *InT*.

### ■ Setting procedure

Setting procedure vary depending on the communication parameter.

- Device address *Add*, interval time *InT*  
Operate UP, DOWN and <R/S key, and input numerals.
- Communication speed *bPS*, data bit configuration *bit*  
Operate UP, DOWN and <R/S key, and choose one among the displayed set value.

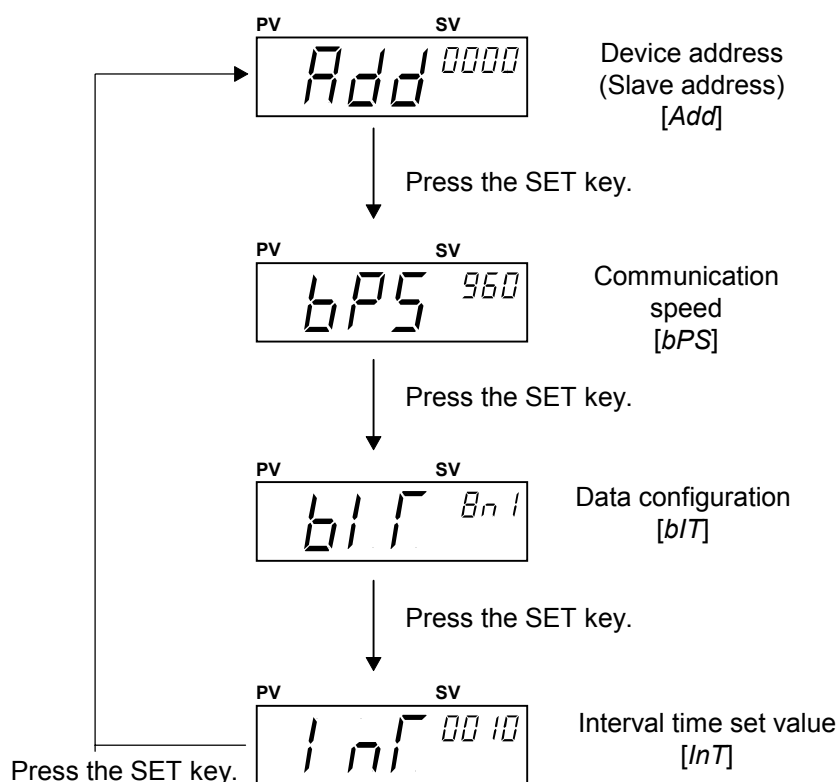

### ■ Registration of set value

After completing all communication parameter settings, turn on the power again, and register the set value which changed.

### ■ Description of each parameters

Symbol	Name	Setting range	Description	Factory set value
<i>Add</i> (Add)	Device address (Slave address)	0 to 99	Please set it not to duplication in multi-drop connection. If the slave address is set to 0 in Modbus, two-way communication cannot be performed.	0
<i>bPS</i> (bPS)	Communication speed	240: 2400 bps 480: 4800 bps 960: 9600 bps 1920: 19200 bps	Set the same communication speed for both the SA201 (slave) and the host computer (master).	960
<i>bit</i> (bit)	Data bit configuration	See data bit configuration table	Set the same data bit configuration for both the SA201 (slave) and the host computer (master).	8n1
<i>InT</i> (InT)	Interval time *	0 to 250 ms	The SA201's interval time must match the specifications of the host computer.	10

Data bit configuration table

Set value	Data bit	Parity bit	Stop bit
<i>7n1</i> (7n1)	7	Without	1
<i>7n2</i> (7n2)	7	Without	2
<i>7E1</i> (7E1)	7	Even	1
<i>7E2</i> (7E2)	7	Even	2
<i>7o1</i> (7o1)	7	Odd	1
<i>7o2</i> (7o2)	7	Odd	2
<i>8n1</i> (8n1)	8	Without	1
<i>8n2</i> (8n2)	8	Without	2
<i>8E1</i> (8E1)	8	Even	1
<i>8E2</i> (8E2)	8	Even	2
<i>8o1</i> (8o1)	8	Odd	1
<i>8o2</i> (8o2)	8	Odd	2

Setting range of RKC communication

Setting range of Modbus

\* The interval time for the SA201 should be set to provide a time for host computer to finish sending all data including stop bit and to switch the line to receive data. If the interval time between the two is too short, the SA201 may send data before the host computer is ready to receive it. In this case, communication transmission can not be conducted correctly. For a successful communication sequence to occur, the SA201's interval time must match the specifications of the host computer.

### ■ Setting procedure example

1. Go to the communication setting mode so that device address (slave address), *Add*, is displayed. Present set value is displayed, and the least significant digit blinks.

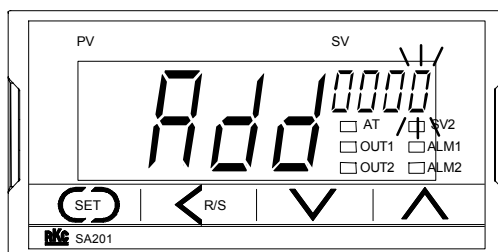

Device address (Slave address)

2. Set the device address. Press the UP key to enter 5 at the least significant digit.  
Example: Setting the device address (slave address) to 15.

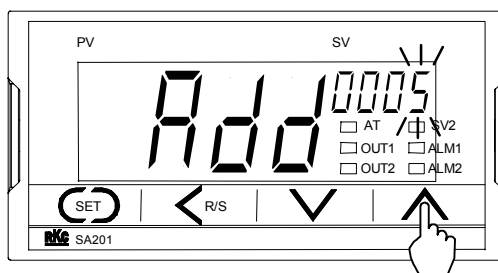

3. Press the <R/S key to blink the tens digit.

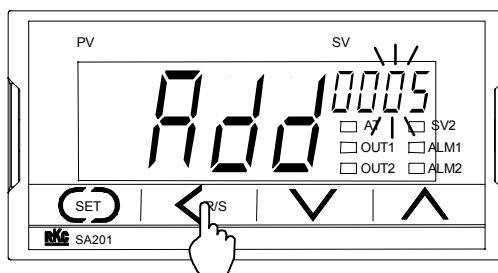

Continued on the next page.

4. Press the UP key to enter *l* at the tens digit.

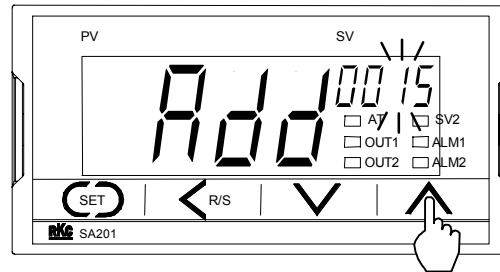

5. Press the SET key to set the value thus set. The display changes to the next communication parameter. If the SET key is not pressed within 1 minute, the present display returns to the PV/SV display mode and the value set here returns to that before the setting is changed.

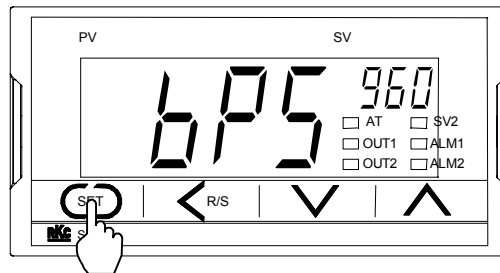

Communication speed

6. After completing all communication parameter settings, turn on the power again, and register the set value which changed.



Besides power on again, register of set value with RUN/ STOP transfer. In this case, have to change to STOP before setting communication parameter. Change to RUN after completing the communication parameter settings, the instrument performs the same operation as that at the time of power on again.



For the RUN/STOP transfer, see the **SA201 Instruction Manual (IMR01K01-E□)**.



## 4.3 Communication Requirements

### ■ Processing times during data send/receive

The SA201 requires the following processing times during data send/receive.

Whether the host computer is using either the polling or selecting procedure for communication, the following processing times are required for SA201 to send data:

- Response wait time after SA201 sends BCC in polling procedure
- Response wait time after SA201 sends ACK or NAK in selecting procedure

#### RKC communication (Polling procedure)

Procedure details	Time (ms)		
	MIN	TYP	MAX
Response send time after SA201 receives ENQ	1.6	4.0	12
Response send time after SA201 receives ACK	1.6	–	10
Response send time after SA201 receives NAK	1.6	–	10
Response send time after SA201 sends BCC	–	–	1.0

#### RKC communication (Selecting procedure)

Procedure details	Time (ms)		
	MIN	TYP	MAX
Response send time after SA201 receives BCC	1.6	3.0	10
Response wait time after SA201 sends ACK	–	–	1.0
Response wait time after SA201 sends NAK	–	–	1.0

#### Modbus

Procedure details	Time (ms)
Read holding registers [03H] Response transmission time after the slave receives the query message	13 ms max.
Preset single register [06H] Response transmission time after the slave receives the query message	6 ms max.
Diagnostics (loopback test) [08H] Response transmission time after the slave receives the query message	6 ms max.



Response send time is time at having set interval time in 0 ms.

■ **RS-485 (2-wire system) send/receive timing**

The sending and receiving of RS-485 communication is conducted through two wires; consequently, the transmission and reception of data requires precise timing. Typical polling and selecting procedures between the host computer and SA201 are described below:

● **Polling procedure**

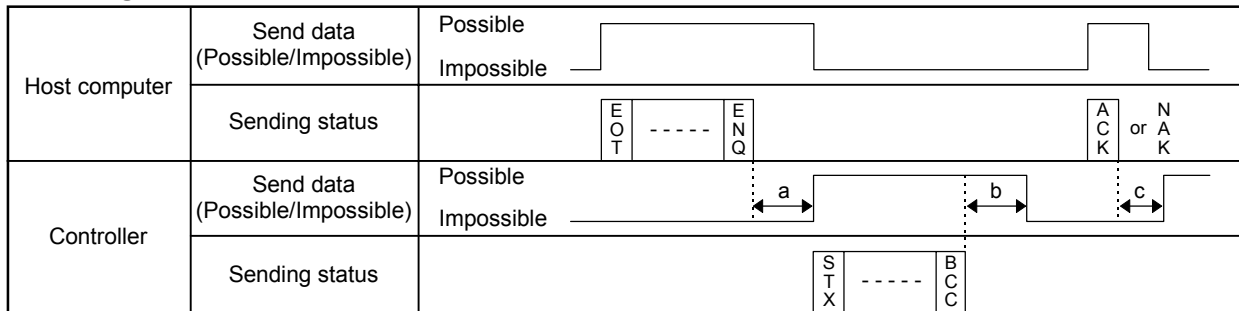

- a: Response send time after SA201 receives [ENQ] + Interval time
- b: Response send time after SA201 sends BCC
- c: Response send time after SA201 receives [ACK] + Interval time or  
Response send time after SA201 receives [NAK] + Interval time

● **Selecting procedure**

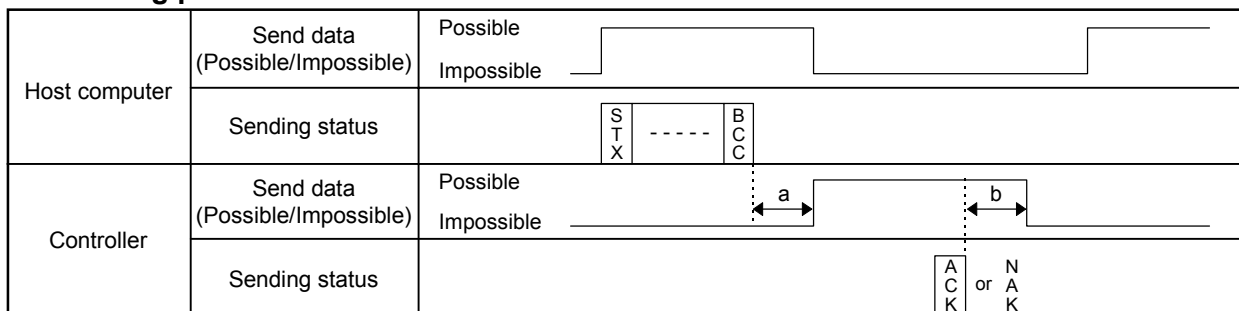

- a: Response send time after SA201 receives BCC + Interval time
- b: Response wait time after SA201 sends ACK or Response wait time after SA201 sends NAK



To switch the host computer from transmission to reception, send data must be on line. To check if data is on line, do not use the host computer's transmission buffer but confirm it by the shift register.



Whether the host computer is using either the polling or selecting procedure for communication, the following processing times are required for SA201 to send data:

- Response wait time after SA201 sends BCC in polling procedure
- Response wait time after SA201 sends ACK or NAK in selecting procedure

■ **Fail-safe**

A transmission error may occur with the transmission line disconnected, shorted or set to the high-impedance state. In order to prevent the above error, it is recommended that the fail-safe function be provided on the receiver side of the host computer. The fail-safe function can prevent a framing error from its occurrence by making the receiver output stable to the MARK (1) when the transmission line is in the high-impedance state.

# 5. RKC COMMUNICATION PROTOCOL

SA201 (hereafter, called controller) uses the polling/selecting method to establish a data link. The basic procedure is followed ANSI X3.28 subcategory 2.5, A4 basic mode data transmission control procedure (Fast selecting is the selecting method used in this controller).

- The polling/selecting procedures are a centralized control method where the host computer controls the entire process. The host computer initiates all communication so the controller responds according to queries and commands from the host.
- The code use in communication is 7-bit ASCII code including transmission control characters. The transmission control characters are EOT (04H), ENQ (05H), ACK (06H), NAK (15H), STX (02H) and ETX (03H). The figures in the parenthesis indicate the corresponding hexadecimal number.

## 5.1 Polling

Polling is the action where the host computer requests one of the connected controllers to transmit data. An example of the polling procedure is shown below:

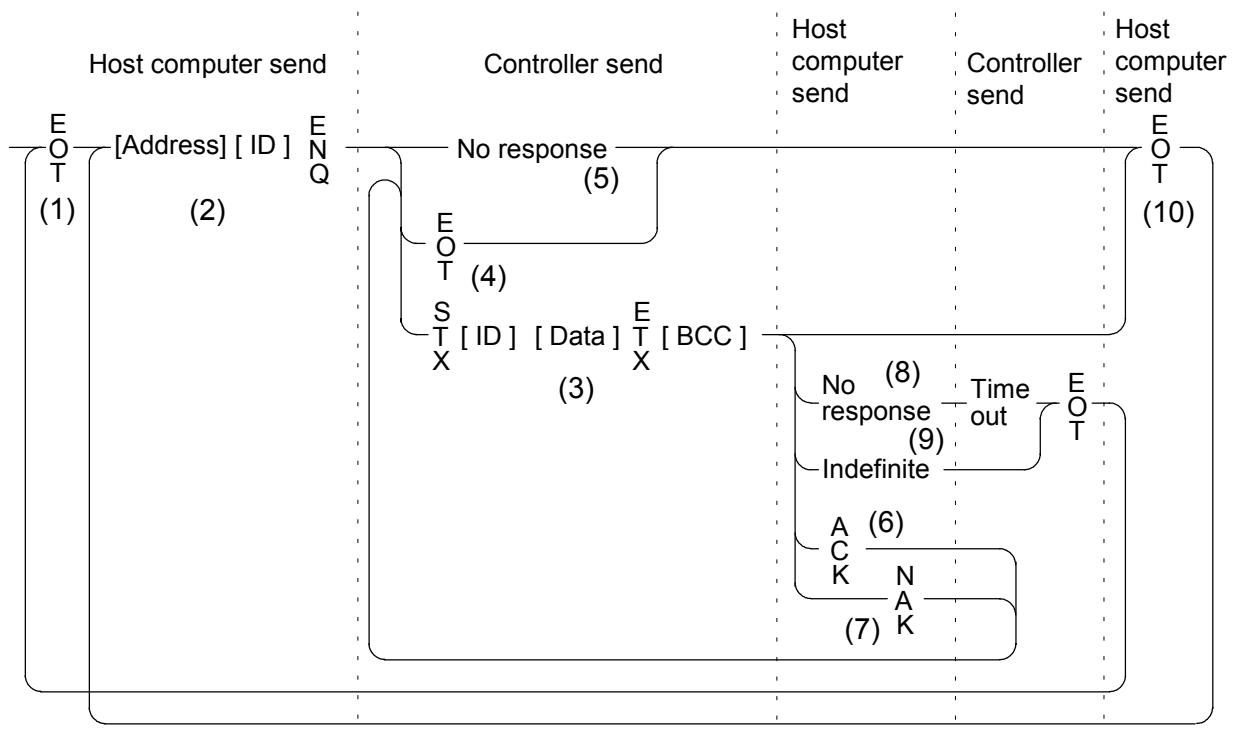

ID: Identifier

### 5.1.1 Polling procedures

#### (1) Data link initialization

Host computer sends EOT to the controllers to initiate data link before polling sequence.

#### (2) Data sent from host computer - Polling sequence

Host computer sends polling sequence with the format shown below:

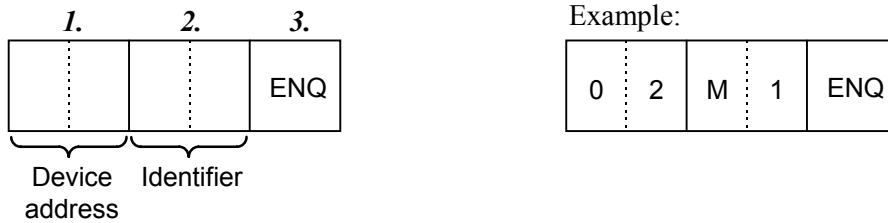

**1. Device address (2 digits)**

The device address specifies the controller to be polled and each controller must have its own unique device address.

For details, see **4.2 Setting the Communication Parameters (P. 7)**.

**2. Identifier (2 digits)**

The identifier specifies the type of data that is requested from the controller.

For details, see **5.3 Communication Identifier List (P. 22)**.

**3. ENQ**

The ENQ is the transmission control character that indicates the end of the polling sequence. The ENQ must be attached to the end of the identifier. The host computer then must wait for a response from the controller.

#### (3) Data sent from the controller

If the polling sequence is received correctly, the controller sends data in the following format:

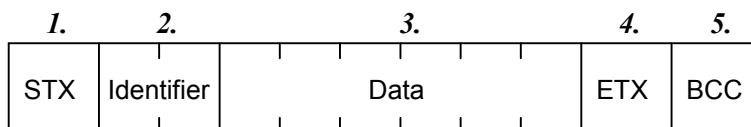

**1. STX**

STX is the transmission control character which indicates the start of the text transmission (identifier and data).

**2. Identifier (2 digits)  For details, see 5.3 Communication Identifier List (P. 22).**

The identifier indicates the type of data (measured value, status and set value) sent to the host computer.

**3. Data (6 digits [Expect model code.] )**

Data is the information being sent from the controller. It is expressed in decimal ASCII code including a minus sign (-) and a decimal point. No zero suppression is made.

**4. ETX**

ETX is a transmission control character used to indicate the end of text transmission.

**5. BCC**

BCC (Block Check Character) detects error using horizontal parity and is calculated by horizontal parity (even number).

Calculation method of BCC: *Exclusive OR* all data and characters from STX through ETX, not including STX.

Example:

STX	M	1	0	0	0	5	0	0	ETX	BCC
-----	---	---	---	---	---	---	---	---	-----	-----

4DH 31H 30H 30H 30H 35H 30H 30H 03H ← Hexadecimal numbers

$$\text{BCC} = 4\text{DH} \oplus 31\text{H} \oplus 30\text{H} \oplus 30\text{H} \oplus 30\text{H} \oplus 35\text{H} \oplus 30\text{H} \oplus 30\text{H} \oplus 03\text{H} = 7\text{AH}$$

Value of BCC becomes 7AH.

**(4) EOT sent from the controller (Ending data transmission from the controller)**

In the following cases, the controller sends EOT to terminate the data link:

- When the specified identifier is invalid
- When there is an error in the data type
- When all the data has been sent

**(5) No response from the controller**

The controller will not respond if the polling address is not received correctly. It may be necessary for the host computer to take corrective action such as a time-out.

### **(6) ACK Acknowledgment**

An acknowledgment ACK is sent by the host computer when data received is correct. When the controller receives ACK from the host computer, the controller will send any remaining data of the next identifier without additional action from the host computer.

 For the identifier, see **5.3 Communication Identifier List (P. 22)**.

When host computer determines to terminate the data link, EOT is sent from the host computer.

### **(7) NAK Negative acknowledge**

If the host computer does not receive correct data from the controller, it sends a negative acknowledgment NAK to the controller. The controller will re-send the same data when NAK is received. This cycle will go on continuously until either recovery is achieved or the data link is corrected at the host computer.

### **(8) No response from host computer**

When the host computer does not respond within approximately three seconds after the controller sends data, the controller sends EOT to terminate the data link.

### **(9) Indefinite response from host computer**

The controller sends EOT to terminate the data link when the host computer response is indefinite.

### **(10) EOT Data link termination**

The host computer sends EOT message when it is necessary to suspend communication with the controller or to terminate the data link due lack of response from the controller.

### 5.1.2 Polling procedure example

#### ■ Normal transmission

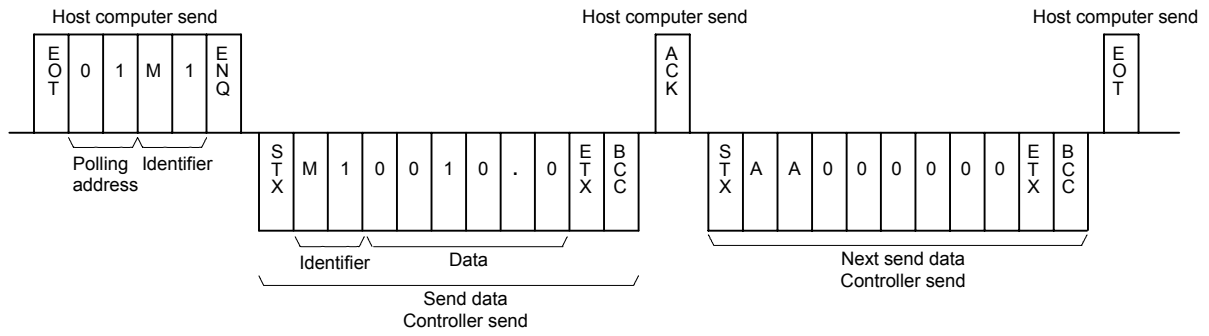

#### ■ Error transmission

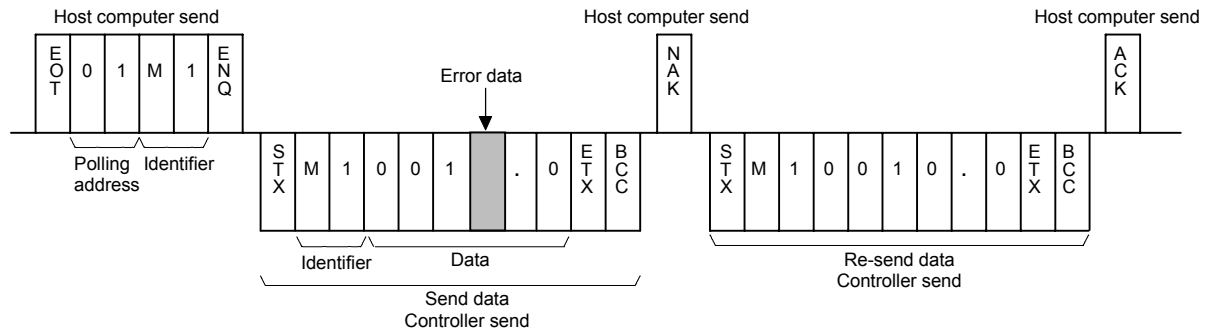

## 5.2 Selecting

Selecting is the action where the host computer requests one of the connected controllers to receive data. An example of the selecting procedure is shown below:

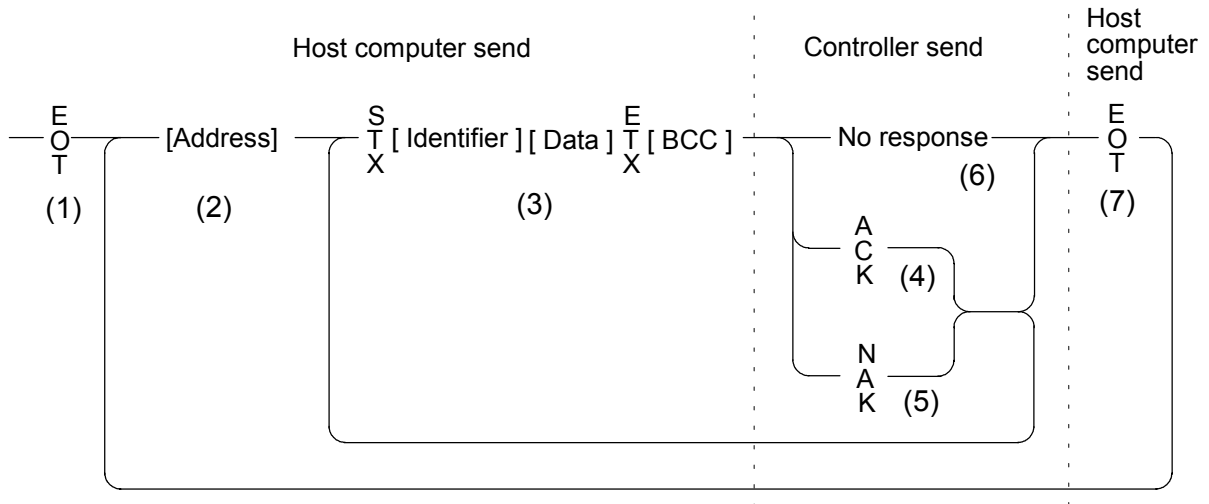

### 5.2.1 Selecting procedures

#### (1) Data link initialization

Host computer sends EOT to the controllers to initiate data link before selecting sequence.

#### (2) Sending selecting address from the host computer

Host computer sends selecting address for the selecting sequence.

Device address (2 digits)

The device address specifies the controller to be selected and each controller must have its own unique device address.

 For details, see **4.2 Setting the Communication Parameters (P. 7)**.



### (3) Data sent from the host computer

The host computer sends data for the selecting sequence with the following format:

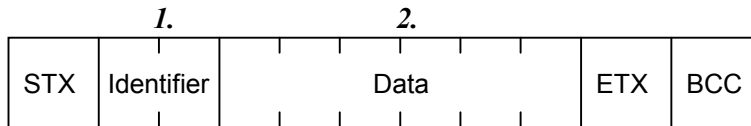

☞ For the STX, ETX and BCC, see **5.1 Polling (P. 13)**.

#### 1. Identifier (2 digits)

The identifier specifies the type of data that is requested from the controller, such as set value.

☞ For details, see **5.3 Communication Identifier List (P. 22)**.

#### 2. Data (Maximum 6 digits)

Data is the information being sent to the controller. It is expressed in decimal ASCII code including a minus sign (-) and a decimal point (period).

#### ● About numerical data

The data that receipt of letter is possible

- Data with numbers below the decimal point omitted or zero suppressed data can be received.

<Example> When data send with -001.5, -01.5, -1.5, -1.50, -1.500 at the time of -1.5, controller can receive a data.

- When the host computer send data with decimal point to item of without decimal point, controller receives a message with the value which cut off below the decimal point.

<Example> When setting range is 0 to 200, controller receives as a following.

<b>Send data</b>	0.5	100.5
<b>Receive data</b>	0	100

- Controller receives value in accordance with decided place after the decimal point. The value below the decided place after the decimal point is cut off.

<Example> When setting range is -10.00 to +10.00, controller receives as a following.

<b>Send data</b>	-.5	-.058	.05	-0
<b>Receive data</b>	-0.50	-0.05	0.05	0.00

The data that receipt of letter is impossible

Controller sends NAK when received a following data.

+	Plus sign and the data that gained plus sing
-	Only minus sign (there is no figure)
.	Only decimal point (period)
-.	Only minus sign and decimal point (period)

#### **(4) ACK Acknowledgment**

An acknowledgment ACK is sent by the controller when data received is correct. When the host computer receives ACK from the controller, the host computer will send any remaining data. If there is no more data to be sent to controller, the host computer sends EOT to terminate the data link.

#### **(5) Negative acknowledge NAK**

If the controller does not receive correct data from the host computer, it sends a negative acknowledgment NAK to the host computer. Corrections, such as re-send, must be made at the host computer. The controller will send NAK in the following cases:

- When an error occurs on communication the line (parity, framing error, etc.)
- When a BCC check error occurs
- When the specified identifier is invalid
- When receive data exceeds the setting range

#### **(6) No response from controller**

The controller does not respond when it can not receive the selecting address, STX, ETX or BCC.

#### **(7) EOT Data link termination**

The host computer sends EOT when there is no more data to be sent from the host computer or there is no response from the controller.

## 5.2.2 Selecting procedure example

### ■ Normal transmission

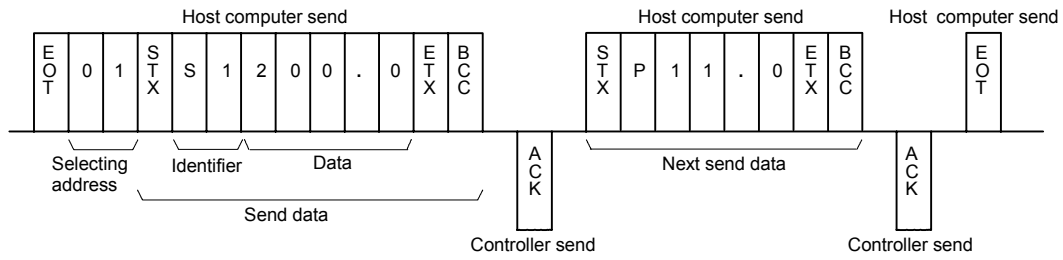

### ■ Error transmission

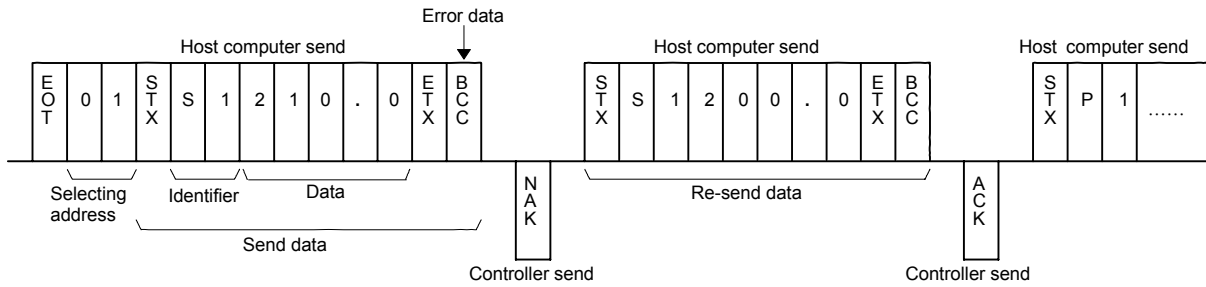

### 5.3 Communication Identifier List



Communication is not possible when an identifier is specified that the controller can not recognize.



The number of digits for data is 6.

(Attribute RO: Read only, R/W: Read and Write)

Name	Identifier	Description	Factory set value	Attribute
Model code	<b>ID</b>	Display the model code	----	RO
Measured value (PV)	<b>M1</b>	Within input range.	----	RO
Burnout	<b>B1</b>	0: OFF            1: ON	----	RO
Alarm 1 status	<b>AA</b>	0: OFF            1: ON	----	RO
Alarm 2 status	<b>AB</b>	0: OFF            1: ON	----	RO
Heat-side manipulated output value	<b>O1</b>	-5.0 to +105.0 %	----	RO
Cool-side manipulated output value	<b>O2</b>	-5.0 to +105.0 %	----	RO
Error code <sup>1</sup>	<b>ER</b>	0: No error Except 0: Error occurs	----	RO
RUN/STOP function	<b>SR</b>	0: RUN            1: STOP	0	R/W
Autotuning	<b>G1</b>	0: Autotuning OFF 1: Autotuning ON After autotuning is completed, setting will automatically change to 0.	0	R/W
Self-tuning	<b>G2</b>	0: Self-tuning OFF 1: Self-tuning ON	0	R/W <sup>2</sup>
Set value (SV)	<b>S1</b>	Within input range.	Temperature input: 0 or 0.0 Voltage/current inputs: 0.0	R/W

<sup>1</sup> Any number other than 0 indicates errors (RAM write error, etc.) detected by the controller self-diagnosis function. Please contact RKC sales office or the agent.

<sup>2</sup> If the heat/cool PID control with autotuning (water cooling/air cooling) is selected, or the set value of any one of the heat/cool proportional band, integral time, derivative time and anti-reset windup is set to 0, the attribute becomes RO.

Continued on the next page.

Continued from the previous page.

(Attribute RO: Read only, R/W: Read and Write)

Name	Identifier	Description	Factory set value	Attribute
Alarm 1 set value	A1	Process alarm, SV alarm: Setting limiter (low limit) to setting limiter (high limit)	Temperature input: 50 or 50.0	R/W <sup>1</sup>
Alarm 2 set value	A2	Deviation alarm: -span to +span However, within -1999 to +9999 °C [°F] or -199.9 to +999.9 °C [°F]	Voltage/current inputs: 5.0	R/W <sup>2</sup>
Control loop break alarm	A5	0.0 to 200.0 minutes (0.0: OFF)	8.0	R/W <sup>3</sup>
Control loop break alarm deadband	A6	0 (0.0) to span However, less than 9999	0	R/W <sup>3</sup>
Heat-side proportional band	P1	Temperature input: 0 (0.0) to span or 9999 (999.9) °C [°F] (0 or 0.0: ON/OFF action) Voltage/current inputs: 0.1 to span <i>Cannot be written while the self-tuning function is on, only Read is available.</i>	Temperature input: 30 or 30.0 Voltage/current inputs: 3.0	R/W
Integral time	I1	0 to 3600 seconds (0: PD action) <i>Cannot be written while the self-tuning function is on, only Read is available.</i>	240	R/W
Derivative time	D1	0 to 3600 seconds (0: PI action) <i>Cannot be written while the self-tuning function is on, only Read is available.</i>	60	R/W
Anti-reset windup	W1	0 to 100 % of heat-side proportional band (0: Integral action OFF) <i>Cannot be written while the self-tuning function is on, only Read is available.</i>	100	R/W
Heat-side proportioning cycle time	T0	1 to 100 seconds	Note1	R/W

<sup>1</sup> If no alarm for first alarm or control loop break alarm is selected, the attribute becomes RO.<sup>2</sup> If no alarm for second alarm is selected, the attribute becomes RO.<sup>3</sup> If control loop break alarm for first alarm is not selected, the attribute becomes RO.

Note1 Relay contact output: 20 Voltage pulse output: 2

Continued on the next page.

Continued from the previous page.

(Attribute RO: Read only, R/W: Read and Write)

Name	Identifier	Description	Factory set value	Attribute
Cool-side proportional band	<b>P2</b>	1 to 1000 % of heat-side proportional band	100	R/W <sup>1</sup>
Overlap/deadband	<b>V1</b>	-span to +span However, within -1999 to +9999 °C [°F] or -199.9 to +999.9 °C [°F]	0 or 0.0	R/W <sup>1</sup>
Cool-side proportioning cycle time	<b>T1</b>	1 to 100 seconds	Note1	R/W <sup>1</sup>
PV bias	<b>PB</b>	-span to +span However, within -1999 to +9999 °C [°F] or -199.9 to +999.9 °C [°F]	Temperature input: 0 or 0.0 Voltage/current inputs: 0.0	R/W
Digital filter	<b>F1</b>	0 to 100 seconds (0: OFF)	0	R/W
Set data lock function <sup>2</sup>	<b>LK</b>	0000 to 1111	0000	R/W

<sup>1</sup> If heat/cool PID control with autotuning (water cooling/air cooling) for control type is not selected, the attribute becomes RO.

<sup>2</sup> Details of set data lock function:

Set data	Set value (SV)	Alarm setting (First alarm, Second alarm)	Other setting items
0000	×	×	×
0001	×	×	—
0010	×	—	×
0011	×	—	—
0100	—	×	×
0101	—	×	—
0110	—	—	×
1111	—	—	—

(×) Settable-Data unlocked      (-) Unsettable-Data locked

The data lock function only prevents setting changes being made from the front keys. Setting changes can still be made through communication transmission.

Note1 Relay contact output: 20

Voltage pulse output: 2

Continued on the next page.

Continued from the previous page.

(Attribute RO: Read only, R/W: Read and Write)

Name	Identifier	Description	Factory set value	Attribute
EEPROM storage mode <sup>1</sup>	<b>EB</b>	0: Backup mode (Set values are store to the EEPROM) 1: Buffer mode (No set values are store to the EEPROM)	0	R/W
EEPROM storage status <sup>2</sup>	<b>EM</b>	0: Mismatch 1: Match	----	RO

<sup>1</sup> The non-volatile memory (EEPROM) has limitations on the number of memory rewrite times. If the buffer mode is selected as an EEPROM storage mode, all of the set values changed are not written to the EEPROM and thus a problem of limitations on the number of memory rewrite times can be solved. When the memory is used to frequently change the set value via communication, select the buffer mode.

When selecting any EEPROM storage mode, take notice of the following.

- If power failure occurs while the buffer mode is selected, the set value returns to the value before the storage mode is selected.
- If the buffer mode is changed to the backup mode, all of the set values at that time are stored to the EEPROM. If necessary to backup the final value of each set item, select the backup mode.
- When the power is turned on, the backup mode is always set.

<sup>2</sup> The contents of the buffer memory and those of the EEPROM can be checked.

When data is 0: The contents of the buffer memory do not match with those of the EEPROM.

- As data is being written to the EEPROM in backup mode, do not turn the power off. If turned off, no set values are stored.
- If the set value is changed after the backup mode is changed to the buffer mode, 0 is set (mismatch). As the set value changed is not backup, select the backup mode if necessary.

When data is 1: The contents of the buffer memory match with those of the EEPROM.

(Data write to the EEPROM is completed.)

# 6. MODBUS COMMUNICATION PROTOCOL

---

The master controls communication between master and slave. A typical message consists of a request (query message) sent from the master followed by an answer (response message) from the slave. When master begins data transmission, a set of data is sent to the slave in a fixed sequence. When it is received, the slave decodes it, takes the necessary action, and returns data to the master.

## 6.1 Message Format

The message consists of four parts: slave address, function code, data, and error check code which are always transmitted in the same sequence.

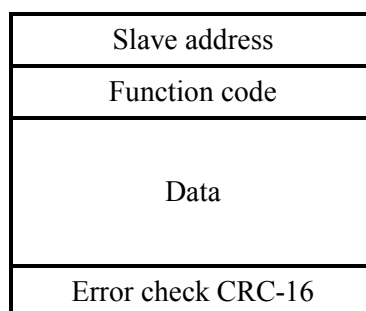

Message format

### ■ Slave address

The slave address is a number from 1 to 99 manually set at the front key panel of the controller.

 For details, see **4.2 Setting the Communication Parameters (P. 7)**.

Although all connected slaves receive the query message sent from the master, only the slave with the slave address coinciding with the query message will accept the message.

### ■ Function code

The function codes are the instructions set at the master and sent to the slave describing the action to be executed. The function codes are included when the slave responds to the master.

 For details, see **6.2 Function Code (P. 27)**.

### ■ Data

The data to execute the function specified by the function code is sent to the slave and corresponding data returned to the master from the slave.

 For details, see **6.6 Message Format (P. 31)**, **6.7 Data Configuration (P. 34)** and **6.8 Communication Data List (P. 36)**.

### ■ Error check

An error checking code (CRC-16: Cyclic Redundancy Check) is used to detect an error in the signal transmission.

 For the calculation method of CRC-16, see **6.5 Calculating CRC-16 (P. 29)**.



## 6.2 Function Code

### Function code contents

Function code (Hexadecimal)	Function	Contents
03H	Read holding registers	Measured value (PV), alarm status, etc.
06H	Preset single register	Set value (SV), alarm set value, PID constants, PV bias, etc. (For each word)
08H	Diagnostics (loopback test)	Diagnostics (loopback test)

### Message length of each function (Unit: byte)

Function code (Hexadecimal)	Function	Query message		Response message	
		Min	Max	Min	Max
03H	Read holding registers	8	8	7	255
06H	Preset single register	8	8	8	8
08H	Diagnostics (loopback test)	8	8	8	8

## 6.3 Communication Mode

Signal transmission between the master and slaves is conducted in Remote Terminal Unit (RTU) mode.

### RTU mode

Items	Contents
Data bit length	8 bit (Binary)
Start mark of message	Unused
End mark of message	Unused
Message length	See <b>6.2 Function Code (P. 27)</b>
Data time interval	24 bit's time or less *
Error check	CRC-16 (Cyclic Redundancy Check)

\* The data time intervals in one query message from the master must be 24 bit's time or less. If the data time interval exceeds 24 bit's time, the slave regards the transmission as ended and because the message format is incomplete, the slave does not respond.

## 6.4 Slave Responses

### (1) Normal response

- In the response message of the Read Holding Registers, the slave returns the read out data and the number of data items with the same slave address and function code as the query message.
- In the response message of the Preset Single Resister, the slave returns the same message as the query message.
- In the response message of the Diagnostics (loopback test), the slave returns the same message as the query message.

### (2) Defective message response

- If the query message from the master is defective, except for transmission error, the slave returns the error response message without any action.

Slave address
Function code
Error code
Error check CRC-16

Error response message

- If the self-diagnostic function of the slave detects an error, the slave will return an error response message to all query messages.
- The function code of each error response message is obtained by adding 80H to the function code of the query message.

Error code	Contents
1	Function code error (Specifying nonexistent function code)
2	When written to read only (RO) data, When any address other than 0000H to 001AH is specified, etc.
3	When the data written exceeds the setting range, When the specified number of data items in the query message exceeds the maximum number of data items available
4	Self-diagnostic error response

### (3) No response

The slave ignores the query message and does not respond when:

- The slave address in the query message does not coincide with any slave address settings.
- The CRC code of the master does not coincide with that of the slave.
- Transmission error such as overrun, framing, parity and etc., is found in the query message.
- Data time interval in the query message from the master exceeds 24 bit's time.

---

## 6.5 Calculating CRC-16

The Cyclic Redundancy Check (CRC) is a 2 byte (16-bit) error check code. After constructing the data message, not including start, stop, or parity bit, the master calculates a CRC code and appends this to the end of the message. The slave will calculate a CRC code from the received message, and compare it with the CRC code from the master. If they do not coincide, a communication error has occurred and the slave does not respond.

The CRC code is formed in the following sequence:

1. Load a 16-bit CRC register with FFFFH.
2. *Exclusive OR* ( $\oplus$ ) the first byte (8 bits) of the message with the CRC register. Return the result to the CRC register.
3. Shift the CRC register 1 bit to the right.
4. If the carry flag is 1, exclusive OR the CRC register with A001 hex and return the result to the CRC register. If the carry flag is 0, repeat step 3.
5. Repeat step 3 and 4 until there have been 8 shifts.
6. *Exclusive OR* the next byte (8 bits) of the message with the CRC register.
7. Repeat step 3 through 6 for all bytes of the message (except the CRC).
8. The CRC register contains the 2 byte CRC error code. When they are appended to the message, the low-order byte is appended first, followed by the high-order byte.

### ■ The flow chart of CRC-16

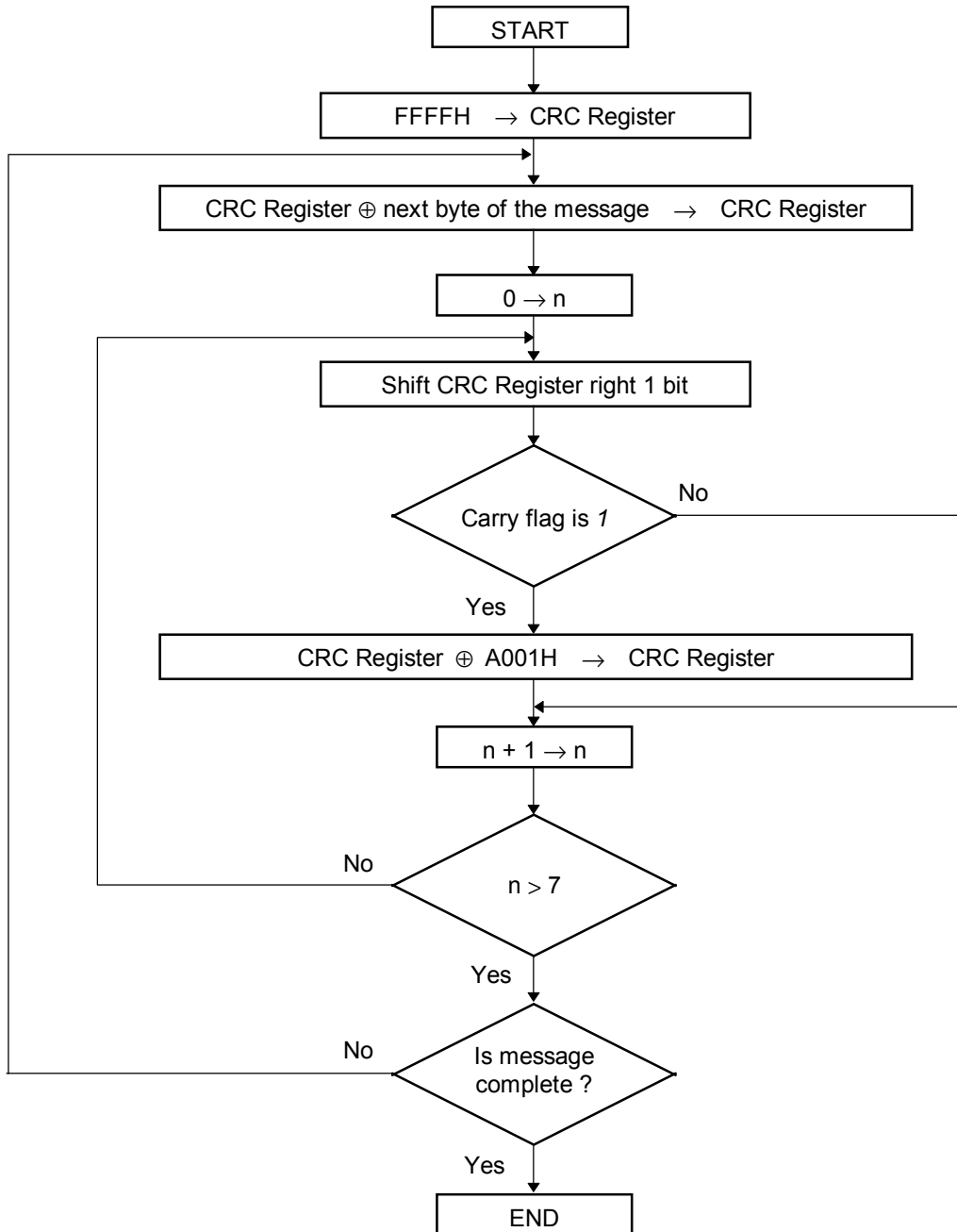

The  $\oplus$  symbol indicates an *exclusive OR* operation. The symbol for the number of data bits is  $n$ .

## 6.6 Message Format

### 6.6.1 Read holding registers [03H]

The query message specifies the starting register address and quantity of registers to be read. The contents of the holding registers are entered in the response message as data, divided into two parts: the high-order 8 bits and the low-order 8 bits, arranged in the order of the register numbers.

Example: The contents of the three holding registers from 0000H to 0002H are the read out from slave address 2.

#### Query message

Slave address		02H	
Function code		03H	
Starting number	High	00H	} First holding register address
	Low	00H	
Quantity	High	00H	} The setting must be between 1 and 125 (0001H and 007DH).
	Low	03H	
CRC-16	High	05H	
	Low	F8H	

#### Normal response message

Slave address		02H	
Function code		03H	
Number of data		06H	→ Number of holding registers × 2
First holding register contents	High	00H	
	Low	00H	
Next holding register contents	High	00H	
	Low	00H	
Next holding register contents	High	00H	
	Low	63H	
CRC-16	High	75H	
	Low	ACH	

#### Error response message

Slave address		02H
80H + Function code		83H
Error code		03H
CRC-16	High	F1H
	Low	31H

### 6.6.2 Preset single register [06H]

The query message specifies data to be written into the designated holding register. The write data is arranged in the query message with high-order 8 bits first and low-order 8 bits next. Only R/W holding registers can be specified.

Example: Data is written into the holding register 0006H of slave address 1.

#### Query message

Slave address		01H	
Function code		06H	
Holding register number	High	00H	} Any data within the range
	Low	10H	
Write data	High	01H	
	Low	02H	
CRC-16	High	08H	
	Low	5EH	

#### Normal response message

Slave address		01H	} Contents will be the same as query message data.
Function code		06H	
Holding register number	High	00H	
	Low	10H	
Write data	High	01H	
	Low	02H	
CRC-16	High	08H	
	Low	5EH	

#### Error response message

Slave address		01H
80H + Function code		86H
Error code		02H
CRC-16	High	CDH
	Low	C1H

### 6.6.3 Diagnostics (loopback test) [08H]

The master's query message will be returned as the response message from the slave. This function checks the communication system between the master and slave.

Example: Loopback test for slave address 1

#### Query message

Slave address		01H	
Function code		08H	
Test code	High	00H	} Test code must be set to 00.
	Low	00H	
Data	High	1FH	} Any pertinent data
	Low	34H	
CRC-16	High	E9H	
	Low	ECH	

#### Normal response message

Slave address		01H	} Contents will be the same as query message data.
Function code		08H	
Test code	High	00H	
	Low	00H	
Data	High	1FH	
	Low	34H	
CRC-16	High	E9H	
	Low	ECH	

#### Error response message

Slave address		01H
80H + Function code		88H
Error code		03H
CRC-16	High	06H
	Low	01H

## 6.7 Data Configuration

### 6.7.1 Data range

The numeric range of data used in Modbus protocol is 0000H to FFFFH. Only the set value within the setting range is effective.



FFFFH represents -1.

### Data processing with decimal points

#### ■ Data with decimal points

##### ● Data with one decimal place

The Modbus protocol does not recognize data with decimal points during communication.

Control loop break alarm

Example: When the control loop break alarm set value is 8.0 minutes; 8.0 is processed as 80, 80 = 0050H

Control loop break alarm	High	00H
	Low	50H

#### ■ Data without decimal points

Alarm 1 status	Anti-reset windup
Alarm 2 status	Heat-side proportioning cycle time
Burnout	Cool-side proportional band
Autotuning	Cool-side proportional cycle time
Self-tuning	Set data lock function
Integral time	RUN/STOP function
Derivative time	

Example: When integral time is 50 seconds; 50 is processed as 50, 50 = 0032H

Integral time	High	00H
	Low	32H



### ■ Data whose decimal point's presence and/or position depends on input range

The position of the decimal point changes depending on the input range type because the Modbus protocol does not recognize data with decimal points during communication.

The following data can have one of three decimal point positions:

- No decimal point
- One decimal place
- Two decimal place

 For details, see **7. INPUT RANGE TABLES (P. 40)**.

Measured value (PV)	Heat-side proportional band
Set value (SV)	Control loop break alarm deadband
Alarm 1 set value	PV bias
Alarm 2 set value	

Example: When the temperature set value is -20.0 °C; -20.0 is processed as -200,  
 $-200 = 0000H - 00C8H = FF38H$

Set value (SV)	High	FFH
	Low	38H

### 6.7.2 Data processing precautions

- For 03H (read holding register), an error response message is returned when the start address is larger than 1AH.
- For 06H (preset single register), an error message is returned when the write address is larger than 1AH.
- Read data of unused channel and undefined address is 0.
- Any attempt to write to an unused channel is not processed as an error. Data can not be written into an unused channel.
- If data range or address error occurs during data writing, the data written before error is in effect.

## 6.8 Communication Data List

The communication data list summarizes data addresses (holding register numbers), names, descriptions, factory set values and attributes.

(Attribute RO: Read only, R/W: Read and Write)

Address	Name	Description	Factory set value	Attribute
00H	Measured value (PV)	Within input range.	----	RO
03H	Alarm 1 status	0: OFF      1: ON	----	RO
04H	Alarm 2 status	0: OFF      1: ON	----	RO
05H	Burnout	0: OFF      1: ON	----	RO
06H	Set value (SV)	Within input range.	Temperature input: 0 or 0.0 Voltage/current inputs: 0	R/W
07H	Alarm 1 set value	Process alarm, SV alarm: Setting limiter (low limit) to setting limiter (high limit)	Temperature input: 50 or 50.0	R/W <sup>1</sup>
08H	Alarm 2 set value	Deviation alarm: -span to +span However, within -1999 to +9999 °C [°F] or -199.9 to +999.9 °C [°F]	Voltage/current inputs: 5.0	R/W <sup>2</sup>
0BH	Control loop break alarm	0.0 to 200.0 minutes (0.0: OFF)	8.0	R/W <sup>3</sup>
0CH	Control loop break alarm deadband	0 (0.0) to span However, less than 9999	0	R/W <sup>3</sup>
0DH	Autotuning	0: Autotuning OFF 1: Autotuning ON After autotuning is completed, setting will automatically change to 0.	0	R/W
0EH	Self-tuning	0: Self-tuning OFF 1: Self-tuning ON	0	R/W <sup>4</sup>

<sup>1</sup> If no alarm for first alarm or control loop break alarm is selected, the attribute becomes RO.

<sup>2</sup> If no alarm for second alarm is selected, the attribute becomes RO.

<sup>3</sup> If control loop break alarm for first alarm is not selected, the attribute becomes RO.

<sup>4</sup> If the heat/cool PID control with autotuning (water cooling/air cooling) is selected, or the set value of any one of the heat/cool proportional band, integral time, derivative time and anti-reset windup is set to 0, the attribute becomes RO.

Continued on the next page.

Continued from the previous page.

(Attribute RO: Read only, R/W: Read and Write)

Address	Name	Description	Factory set value	Attribute
0FH	Heat-side proportional band	Temperature input: 0 (0.0) to span or 9999 (999.9) °C [°F] (0 or 0.0: ON/OFF action) Voltage/current inputs: 0.1 to span <i>Cannot be written while the self-tuning function is on, only Read is available.</i>	Temperature input: 30 or 30.0 Voltage/current inputs: 3.0	R/W
10H	Integral time	0 to 3600 seconds (0: PD action) <i>Cannot be written while the self-tuning function is on, only Read is available.</i>	240	R/W
11H	Deviation time	0 to 3600 seconds (0: PI action) <i>Cannot be written while the self-tuning function is on, only Read is available.</i>	60	R/W
12H	Anti-reset windup	0 to 100 % of heat-side proportional band (0: Integral action OFF) <i>Cannot be written while the self-tuning function is on, only Read is available.</i>	100	R/W
13H	Heat-side proportioning cycle time	1 to 100 seconds	Note1	R/W
14H	Cool-side proportional band	1 to 1000 % of heat-side proportional band	100	R/W *
15H	Overlap/deadband	-span to +span However, within -1999 to +9999 °C [°F] or -199.9 to +999.9 °C [°F]	0 or 0.0	R/W *
16H	Cool-side proportioning cycle time	1 to 100 seconds	Note1	R/W *
17H	PV bias	-span to +span However, within -1999 to +9999 °C [°F] or -199.9 to +999.9 °C [°F]	Temperature input: 0 or 0.0 Voltage/current inputs: 0.0	R/W

Note1 Relay contact output: 20

Voltage pulse output: 2

\* If heat/cool PID control with autotuning (water cooling/air cooling) for control type is not selected, the attribute becomes RO.

Continued on the next page.

Continued from the previous page.

(Attribute RO: Read only, R/W: Read and Write)

Address	Name	Description	Factory set value	Attribute
18H	Set data lock function *	0 to 7	0	R/W
19H	RUN/STOP function	0: RUN 1: STOP	0	R/W
1AH	Digital filter	0 to 100 seconds (0: OFF)	0	R/W

\* Details of set data lock function:

Set data	Set value (SV)	Alarm setting (First alarm, Second alarm)	Other setting items
0	×	×	×
1	×	×	—
2	×	—	×
3	×	—	—
4	—	×	×
5	—	×	—
6	—	—	×
7	—	—	—

(×) Settable-Data unlocked (-) Unsettable-Data locked

The data lock function only prevents setting changes being made from the front keys. Setting changes can still be made through communication transmission.

Continued on the next page.

Continued from the previous page.

(Attribute RO: Read only, R/W: Read and Write)

Address	Name	Description	Factory set value	Attribute
1BH	EEPROM storage mode <sup>1</sup>	0: Backup mode (Set values are store to the EEPROM) 1: Buffer mode (No set values are store to the EEPROM)	0	R/W
1CH	EEPROM storage status <sup>2</sup>	0: Mismatch 1: Match	----	RO
1DH	Heat-side manipulated output value	-5.0 to +105.0 %	----	RO
1EH	Cool-side manipulated output value	-5.0 to +105.0 %	----	RO

<sup>1</sup> The non-volatile memory (EEPROM) has limitations on the number of memory rewrite times. If the buffer mode is selected as an EEPROM storage mode, all of the set values changed are not written to the EEPROM and thus a problem of limitations on the number of memory rewrite times can be solved. When the memory is used to frequently change the set value via communication, select the buffer mode.

When selecting any EEPROM storage mode, take notice of the following.

- If power failure occurs while the buffer mode is selected, the set value returns to the value before the storage mode is selected.
- If the buffer mode is changed to the backup mode, all of the set values at that time are stored to the EEPROM. If necessary to backup the final value of each set item, select the backup mode.
- When the power is turned on, the backup mode is always set.

<sup>2</sup> The contents of the buffer memory and those of the EEPROM can be checked.

When data is 0: The contents of the buffer memory do not match with those of the EEPROM.

- As data is being written to the EEPROM in backup mode, do not turn the power off. If turned off, no set values are stored.
- If the set value is changed after the backup mode is changed to the buffer mode, 0 is set (mismatch). As the set value changed is not backup, select the backup mode if necessary.

When data is 1: The contents of the buffer memory match with those of the EEPROM.

(Data write to the EEPROM is completed.)

# 7. INPUT RANGE TABLES

Input Range Table 1

Input type		Input range	Code	
			Input	Range
Thermocouple	K	0 to 200 °C	K	01
		0 to 400 °C	K	02
		0 to 600 °C	K	03
		0 to 800 °C	K	04
		0 to 1000 °C	K	05
		0 to 1200 °C	K	06
		0 to 1372 °C	K	07
		-199.9 to +300.0 °C	K	08
		0.0 to 400.0 °C	K	09
		0.0 to 800.0 °C	K	10
		0 to 100 °C	K	13
		0 to 300 °C	K	14
		0 to 450 °C	K	17
		0 to 500 °C	K	20
		0.0 to 200.0 °C	K	29
		0.0 to 600.0 °C	K	37
		-199.9 to +800.0 °C	K	38
		0 to 800 °F	K	A1
		0 to 1600 °F	K	A2
		0 to 2502 °F	K	A3
	0.0 to 800.0 °F	K	A4	
	20 to 70 °F	K	A9	
	-199.9 to +999.9 °F	K	B2	
	J	0 to 200 °C	J	01
		0 to 400 °C	J	02
		0 to 600 °C	J	03
		0 to 800 °C	J	04
		0 to 1000 °C	J	05
		0 to 1200 °C	J	06
		-199.9 to +300.0 °C	J	07
0.0 to 400.0 °C		J	08	
0.0 to 800.0 °C		J	09	
0 to 450 °C		J	10	
0.0 to 200.0 °C		J	22	
0.0 to 600.0 °C		J	23	
-199.9 to +600.0 °C	J	30		

Continued on the next page.

Continued from the previous page.

Input type		Input range	Code	
			Input	Range
Thermocouple	J	0 to 800 °F	J	A1
		0 to 1600 °F	J	A2
		0 to 2192 °F	J	A3
		0 to 400 °F	J	A6
		0 to 300 °F	J	A7
		-199.9 to +999.9 °F	J	A9
		0.0 to 800.0 °F	J	B6
	R	0 to 1600 °C <sup>1</sup>	R	01
		0 to 1769 °C <sup>1</sup>	R	02
		0 to 1350 °C <sup>1</sup>	R	04
		0 to 3200 °F <sup>1</sup>	R	A1
		0 to 3216 °F <sup>1</sup>	R	A2
	S	0 to 1600 °C <sup>1</sup>	S	01
		0 to 1769 °C <sup>1</sup>	S	02
		0 to 3200 °F <sup>1</sup>	S	A1
		0 to 3216 °F <sup>1</sup>	S	A2
	B	400 to 1800 °C	B	01
		0 to 1820 °C <sup>1</sup>	B	02
		800 to 3200 °F	B	A1
		0 to 3308 °F <sup>1</sup>	B	A2
	E	0 to 800 °C	E	01
		0 to 1000 °C	E	02
		0 to 1600 °F	E	A1
		0 to 1832 °F	E	A2
	N	0 to 1200 °C	N	01
		0 to 1300 °C	N	02
		0.0 to 800 °C	N	06
		0 to 2300 °F	N	A1
		0 to 2372 °F	N	A2
		0.0 to 999.9 °F	N	A5
	T	-199.9 to +400.0 °C <sup>2</sup>	T	01
		-199.9 to +100.0 °C <sup>2</sup>	T	02
		-100.0 to +200.0 °C	T	03
		0.0 to 350.0 °C	T	04
		-199.9 to +752.0 °F <sup>2</sup>	T	A1
		-100.0 to +200.0 °F	T	A2
-100.0 to +400.0 °F		T	A3	
0.0 to 450.0 °F		T	A4	
0.0 to 752.0 °F		T	A5	

<sup>1</sup> Accuracy is not guaranteed between 0 to 399 °C (0 to 751 °F)<sup>2</sup> Accuracy is not guaranteed between -199.9 to -100.0 °C (-199.9 to -148.0 °F)

Continued on the next page.

Continued from the previous page.

Input type		Input range	Code		
			Input	Range	
Thermocouple	W5Re/W26Re	0 to 2000 °C	W	01	
		0 to 2320 °C	W	02	
		0 to 4000 °F	W	A1	
	PL II	0 to 1300 °C	A	01	
		0 to 1390 °C	A	02	
		0 to 1200 °C	A	03	
		0 to 2400 °F	A	A1	
		0 to 2534 °F	A	A2	
		U	-199.9 to +600.0 °C *	U	01
			-199.9 to +100.0 °C *	U	02
	0.0 to 400.0 °C		U	03	
	-199.9 to +999.9 °F *		U	A1	
	-100.0 to +200.0 °F		U	A2	
	0.0 to 999.9 °F		U	A3	
	L	0 to 400 °C	L	01	
		0 to 800 °C	L	02	
		0 to 800 °F	L	A1	
		0 to 1600 °F	L	A2	
	RTD	Pt100	-199.9 to +649.0 °C	D	01
			-199.9 to +200.0 °C	D	02
-100.0 to +50.0 °C			D	03	
-100.0 to +100.0 °C			D	04	
-100.0 to +200.0 °C			D	05	
0.0 to 50.0 °C			D	06	
0.0 to 100.0 °C			D	07	
0.0 to 200.0 °C			D	08	
0.0 to 300.0 °C			D	09	
0.0 to 500.0 °C			D	10	
-199.9 to +999.9 °F			D	A1	
-199.9 to +400.0 °F			D	A2	
-199.9 to +200.0 °F			D	A3	
-100.0 to +100.0 °F			D	A4	
-100.0 to +300.0 °F			D	A5	
0.0 to 100.0 °F			D	A6	
0.0 to 200.0 °F			D	A7	
0.0 to 400.0 °F			D	A8	
0.0 to 500.0 °F			D	A9	

\* Accuracy is not guaranteed between -199.9 to -100.0 °C (-199.9 to -148.0 °F)

Continued on the next page.



Continued from the previous page.

Input type		Input range	Code	
			Input	Range
RTD	JPt100	-199.9 to +649.0 °C	P	01
		-199.9 to +200.0 °C	P	02
		-100.0 to +50.0 °C	P	03
		-100.0 to +100.0 °C	P	04
		-100.0 to +200.0 °C	P	05
		0.0 to 50.0 °C	P	06
		0.0 to 100.0 °C	P	07
		0.0 to 200.0 °C	P	08
		0.0 to 300.0 °C	P	09
		0.0 to 500.0 °C	P	10

**Input Range Table 2**

Input type		Input range	Code	
			Input	Range
Voltage	0 to 5 V DC	0.0 to 100.0 %	4	01
	0 to 10 V DC		5	01
	1 to 5 V DC		6	01
Current	0 to 20 mA DC		7	01
	4 to 20 mA DC		8	01



For the current input specification, a resistor of 250  $\Omega$  must be connected between the input terminals.

## 8. TROUBLESHOOTING

---



### WARNING

- To prevent electric shock or instrument failure, always turn off the system power before replacing the instrument.
- To prevent electric shock or instrument failure, always turn off the power before mounting or removing the instrument.
- To prevent electric shock or instrument failure, do not turn on the power until all the wiring is completed.
- To prevent electric shock or instrument failure, do not touch the inside of the instrument.
- All wiring must be performed by authorized personnel with electrical experience in this type of work.

### CAUTION

All wiring must be completed before power is turned on to prevent electric shock, instrument failure, or incorrect action.

The power must be turned off before repairing work for input break and output failure including replacement of sensor, contactor or SSR, and all wiring must be completed before power is turned on again.

This section lists some of the main causes and solutions for communication problems.

If you can not solve a problem, please contact RKC sales office or the agent, on confirming the type name and specifications of the product.

#### ■ RKC communication

Problem	Probable cause	Solution
No response	Wrong connection, no connection or disconnection of the communication cable	Confirm the connection method or condition and connect correctly
	Breakage, wrong wiring, or imperfect contact of the communication cable	Confirm the wiring or connector and repair or replace the wrong one
	Mismatch of the setting data of communication speed and data bit configuration with those of the host	Confirm the settings and set them correctly
	Wrong address setting	

Continued on the next page.

Continued from the previous page.

<b>Problem</b>	<b>Probable cause</b>	<b>Solution</b>
No response	Error in the data format	Reexamine the communication program
	Transmission line is not set to the receive state after data send (for RS-485)	
EOT return	The specified identifier is invalid	Confirm the identifier is correct or that with the correct function is specified. Otherwise correct it
	Error in the data format	Reexamine the communication program
NAK return	Error occurs on the line (parity bit error, framing error, etc.)	Confirm the cause of error, and solve the problem appropriately. (Confirm the transmitting data, and resend data)
	BCC error	
	The data exceeds the setting range	Confirm the setting range and transmit correct data
	The specified identifier is invalid	Confirm the identifier is correct or that with the correct function is specified. Otherwise correct it

### ■ Modbus

Problem	Probable cause	Solution
No response	Wrong connection , no connection or disconnection of the communication cable	Confirm the connection method or condition and connect correctly
	Breakage, wrong wiring, or imperfect contact of the communication cable	Confirm the wiring or connector and repair or replace the wrong one
	Mismatch of the setting data of communication speed and data bit configuration with those of the host	Confirm the settings and set them correctly
	Wrong address setting	
	A transmission error (overrun error, framing error, parity error or CRC-16 error) is found in the query message	Re-transmit after time-out occurs or verify communication program
	The time interval between adjacent data in the query message is too long, exceeding 24 bit's time	
Error code 1	Function cod error (Specifying nonexistent function code)	Confirm the function code
Error code 2	When written to read only (RO) data, When any address other than 0000H to 001AH is specified, etc.	Confirm the address of holding register
Error code 3	When the data written exceeds the setting range, When the specified number of data items in the query message exceeds the maximum number of data items available	Confirm the setting data
Error code 4	Self-diagnostic error	Turn off the power to the instrument. If the same error occurs when the power is turned back on, please contact RKC sales office or the agent.

# 9. ASCII 7-BIT CODE TABLE (REFERENCE)



This table is only for use with RKC communication.

					b7	0	0	0	0	1	1	1	1
					b6	0	0	1	1	0	0	1	1
					b5	0	1	0	1	0	1	0	1
b5 to b7	b4	b3	b2	b1		0	1	2	3	4	5	6	7
	0	0	0	0	0	NUL	DLE	SP	0	@	P	'	p
	0	0	0	1	1	SOH	DC1	!	1	A	Q	a	q
	0	0	1	0	2	STX	DC2	”	2	B	R	b	r
	0	0	1	1	3	ETX	DC3	#	3	C	S	c	s
	0	1	0	0	4	EOT	DC4	\$	4	D	T	d	t
	0	1	0	1	5	ENQ	NAK	%	5	E	U	e	u
	0	1	1	0	6	ACK	SYM	&	6	F	V	f	v
	0	1	1	1	7	BEL	ETB	'	7	G	W	g	w
	1	0	0	0	8	BS	CAN	(	8	H	X	h	x
	1	0	0	1	9	HT	EM	)	9	I	Y	i	y
	1	0	1	0	A	LF	SUB	*	:	J	Z	j	z
	1	0	1	1	B	VT	ESC	+	;	K	[	k	{
	1	1	0	0	C	FF	FS	,	<	L	¥	l	
	1	1	0	1	D	CR	GS	-	=	M	]	m	}
	1	1	1	0	E	SO	RS	.	>	N	^	n	~
	1	1	1	1	F	SI	US	/	?	O	_	o	DEL

# **MEMO**





**RKC INSTRUMENT INC.**

HEADQUARTERS: 16-6, KUGAHARA 5-CHOME, OHTA-KU TOKYO 146-8515 JAPAN

PHONE: 03-3751-9799 (+81 3 3751 9799)

E-mail: [info@rkcinst.co.jp](mailto:info@rkcinst.co.jp)

FAX: 03-3751-8585 (+81 3 3751 8585)