Resin Pressure Digital Controller

HA430/HA930

***DeviceNet
Communication
Instruction Manual***

- DeviceNet is a registered trademark of Open DeviceNet Vendor Association, Inc.
- The name of each programmable controller (PLC) means the products of each manufacturer.
- Company names and product names used in this manual are the trademarks or registered trademarks of the respective companies.
- This product has been self-tested by RKC at DeviceNet Protocol Conformance Test Software Version A-15.

Thank you for purchasing this RKC product. In order to achieve maximum performance and ensure proper operation of your new instrument, carefully read all the instructions in this manual. Please place the manual in a convenient location for easy reference.

SYMBOLS

WARNING : This mark indicates precautions that must be taken if there is danger of electric shock, fire, etc., which could result in loss of life or injury.

CAUTION : This mark indicates that if these precautions and operating procedures are not taken, damage to the instrument may result.



: This mark indicates that all precautions should be taken for safe usage.



: This mark indicates important information on installation, handling and operating procedures.



: This mark indicates supplemental information on installation, handling and operating procedures.



: This mark indicates where additional information may be located.



WARNING

- An external protection device must be installed if failure of this instrument could result in damage to the instrument, equipment or injury to personnel.
- All wiring must be completed before power is turned on to prevent electric shock, fire or damage to instrument and equipment.
- This instrument must be used in accordance with the specifications to prevent fire or damage to instrument and equipment.
- This instrument is not intended for use in locations subject to flammable or explosive gases.
- Do not touch high-voltage connections such as power supply terminals, etc. to avoid electric shock.
- RKC is not responsible if this instrument is repaired, modified or disassembled by other than factory-approved personnel. Malfunction can occur and warranty is void under these conditions.

CAUTION

- This product is intended for use with industrial machines, test and measuring equipment. (It is not designed for use with medical equipment and nuclear energy.)
- This is a Class A instrument. In a domestic environment, this instrument may cause radio interference, in which case the user may be required to take additional measures.
- This instrument is protected from electric shock by reinforced insulation. Provide reinforced insulation between the wire for the input signal and the wires for instrument power supply, source of power and loads.
- Be sure to provide an appropriate surge control circuit respectively for the following:
 - If input/output or signal lines within the building are longer than 30 meters.
 - If input/output or signal lines leave the building, regardless the length.
- This instrument is designed for installation in an enclosed instrumentation panel. All high-voltage connections such as power supply terminals must be enclosed in the instrumentation panel to avoid electric shock by operating personnel.
- All precautions described in this manual should be taken to avoid damage to the instrument or equipment.
- All wiring must be in accordance with local codes and regulations.
- All wiring must be completed before power is turned on to prevent electric shock, instrument failure, or incorrect action.
The power must be turned off before repairing work for input break and output failure including replacement of sensor, contactor or SSR, and all wiring must be completed before power is turned on again.
- To prevent instrument damage or failure, protect the power line and the input/output lines from high currents with a protection device such as fuse, circuit breaker, etc.
- Prevent metal fragments or lead wire scraps from falling inside instrument case to avoid electric shock, fire or malfunction.
- Tighten each terminal screw to the specified torque found in the manual to avoid electric shock, fire or malfunction.
- For proper operation of this instrument, provide adequate ventilation for heat dispensation.
- Do not connect wires to unused terminals as this will interfere with proper operation of the instrument.
- Turn off the power supply before cleaning the instrument.
- Do not use a volatile solvent such as paint thinner to clean the instrument. Deformation or discoloration will occur. Use a soft, dry cloth to remove stains from the instrument.
- To avoid damage to instrument display, do not rub with an abrasive material or push front panel with a hard object.
- When high alarm with hold action/re-hold action is used for Alarm function, alarm does not turn on while hold action is in operation. Take measures to prevent overheating which may occur if the control device fails.

NOTICE

- This manual assumes that the reader has a fundamental knowledge of the principles of electricity, process control, computer technology and communications.
- The figures, diagrams and numeric values used in this manual are only for purpose of illustration.
- RKC is not responsible for any damage or injury that is caused as a result of using this instrument, instrument failure or indirect damage.
- RKC is not responsible for any damage and/or injury resulting from the use of instruments made by imitating this instrument.
- Periodic maintenance is required for safe and proper operation of this instrument. Some components have a limited service life, or characteristics that change over time.
- Every effort has been made to ensure accuracy of all information contained herein. RKC makes no warranty expressed or implied, with respect to the accuracy of the information. The information in this manual is subject to change without prior notice.
- No portion of this document may be reprinted, modified, copied, transmitted, digitized, stored, processed or retrieved through any mechanical, electronic, optical or other means without prior written approval from RKC.

CONTENTS

	Page
1. OUTLINE	1
1.1 Product Outline	1
1.1.1 Communication port	1
1.1.2 EDS file	2
2. SPECIFICATIONS	3
3. CONNECTIONS	4
3.1 Connection Outline of DeviceNet	4
3.2 Connection to DeviceNet	5
4. SETTING	7
4.1 DeviceNet Setting	7
4.1.1 Transfer to setup setting mode	8
4.1.2 Node address and DeviceNet communication speed setting	9
5. DeviceNet COMMUNICATIONS	11
5.1 Features and Functionality	11
5.2 Communication Method	12
5.2.1 Polling I/O communication	12
5.2.2 Explicit message communication	15
5.3 Communication Items List	18
6. COMMUNICATION DATA DESCRIPTION	39

	Page
7. USAGE EXAMPLE	122
7.1 Handling Procedures	122
7.2 System Configuration	123
7.3 Hardware Setting	124
7.4 Sample Programs	125
7.4.1 Polling I/O communication (When the SYSMAC CS1)	125
7.4.2 Polling I/O communication (When the Control Logix 5550)	129
7.4.3 Explicit message communication	133
 8. TROUBLESHOOTING	 138
 APPENDIX	 139
A. Device Profiles	139
A.1 Basic data	139
A.2 Object mounting	140

1. OUTLINE

This manual describes DeviceNet specification, wiring, setting, and data instructions for the Resin Pressure Digital Controller HA430/930.

1.1 Product Outline

The Resin Pressure Digital Controller HA430/930 (hereafter called the “controller”) can send and receive data to/from DeviceNet compatible programmable controller (hereafter called PLC) and personal computers by the DeviceNet that is a multivendor compatible open field network.

On DeviceNet, a computer or a PLC is a master device, and the Controller is a slave device.

1.1.1 Communication port

The controller have one communication port.

- **DeviceNet communication port**

This is a port to be connected to DeviceNet. The connector is of the open-style hard-wired type.

 For DeviceNet, refer to the website of ODVA (Open DeviceNet Vender Association).
<http://www.odva.org>

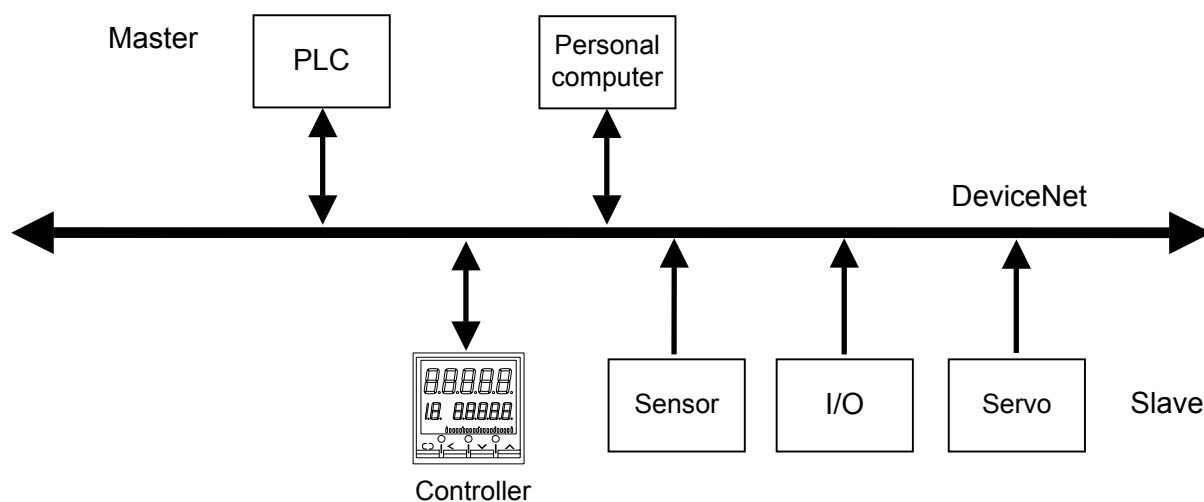

System configuration example

1.1.2 EDS file

The EDS file for the controller can be downloaded from the official RKC website:

http://www.rkcinst.com/english/download/field_network.htm.

Use the EDS file when recognizing the controller on the DeviceNet by using a configurator (tool used to set a master or slave environment on the DeviceNet) of each manufacturer.



For details, refer to Configuration Tool Instruction Manual of each company or Instruction Manual of the master product.

2. SPECIFICATIONS

■ DeviceNet communication

Protocol: DeviceNet

Supported connection: Polling I/O, Explicit message

Connection method: Multi-drop connection, T-branch connection
(Terminating resistor is necessary)

Communication speed: 125 kbps, 250 kbps, 500 kbps
(Communication speed can be selected with switch)
Factory set value: 125 kbps

Communication length:

Communication speed	Maximum network length *		Maximum drop length	Cumulative drop length
	Thick trunk length	Thin trunk length		
125 kbps	500 m	100 m	6 m	156 m or less
250 kbps	250 m			78 m or less
500 kbps	100 m			39 m or less

* The maximum of length between nodes

Maximum number of connection nodes:

64 (including master)

Error control: CRC error, Node address (MAC ID) duplication check

Conforms to DeviceNet specification:

Volume I –Release2.0

Volume II –Release2.0

Device profile name: Generic Device

Connection cable: Use the special cable

Connector type: Open-style connector or Micro-style connector

Termination resistor: 121 Ω, 1/4 W (externally connected)

☞ For details of the device profile, refer to the **APPENDIX A. Device Profiles (P. 139)**.

3. CONNECTIONS

⚠ WARNING

To prevent electric shock or instrument failure, turn off the power before connecting or disconnecting the instrument and peripheral equipment.

3.1 Connection Outline of DeviceNet

The following diagram shows the configuration of a DeviceNet network.

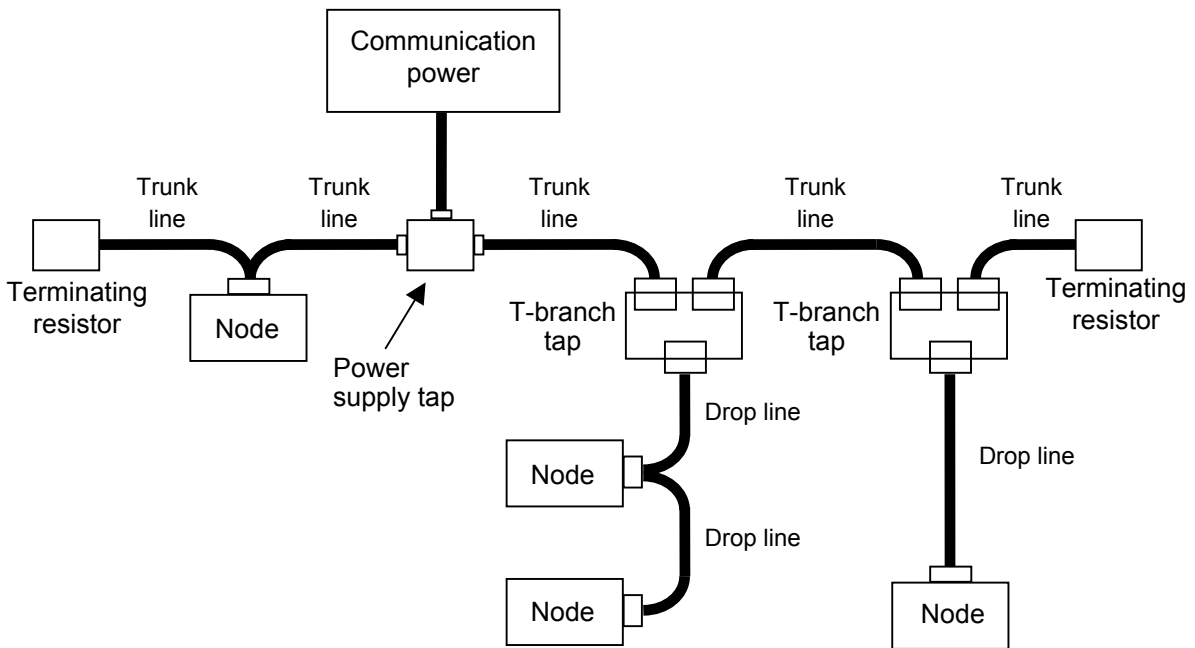

Network configuration example

- **Nodes**

There are two kinds of nodes of master and slave in DeviceNet. The master and slaves can be connected at any location in the network

- **Trunk/Drop lines**

The trunk line refers to the cable that has Terminating Resistors on both ends. Cables branching from the trunk line are known as drop lines.

Use the DeviceNet communication cable (thick or thin cable) for Trunk/Drop lines.

- **Connection methods**

Two methods can be used to connect DeviceNet nodes: The T-branch method and the multi-drop method. With the T-branch method, the node is connected to a drop line created with a T-branch Tap. With the multi-drop method, the node is directly connected to the trunk line or the drop line.

- **Terminating resistors**

Install terminating resistors to both ends of a trunk line in DeviceNet.

Specification of terminating resistor: 121 Ω, ±1 %, 1/4 W (Metal film resistance)

- **Communications power supplies**

To use DeviceNet, connect a communications power supply (24 V DC) to the communications connector of each node with a cable.

- **Communication length**

Communication speed	Maximum network length *		Maximum drop length	Cumulative drop length
	Thick trunk length	Thin trunk length		
125 kbps	500 m	100 m	6 m	156 m or less
250 kbps	250 m			78 m or less
500 kbps	100 m			39 m or less

* The maximum of length between nodes

 For details of DeviceNet Network installation conditions and methods, refer to the instruction manual of the DeviceNet master unit or DeviceNet Specifications. DeviceNet specifications are available at ODVA (Open DeviceNet Vendor Association, <http://www.odva.org>).

3.2 Connection to DeviceNet

- **Open-style connector**

Communication terminal number and signal details

Terminal No.	Signal Name	Symbol	Cable Color
25	Power supply plus (+)	V+	Red
26	Communication data High	CAN_H	White
27	Shield	Drain	None
28	Communication data Low	CAN_L	Blue
29	Power supply minus (-)	V-	Black

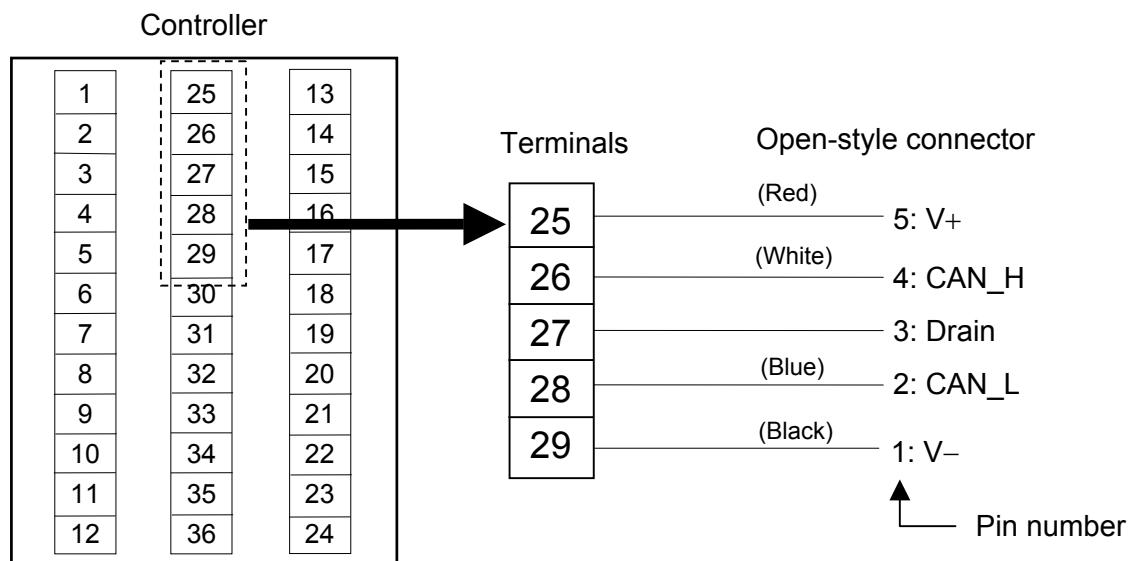

- **Connection plugs (recommended models)**

MSTB2.5/5-STF-5.08AU M: PHOENIX CONTACT, Inc.

■ **Micro-style connector or Mini type connector**

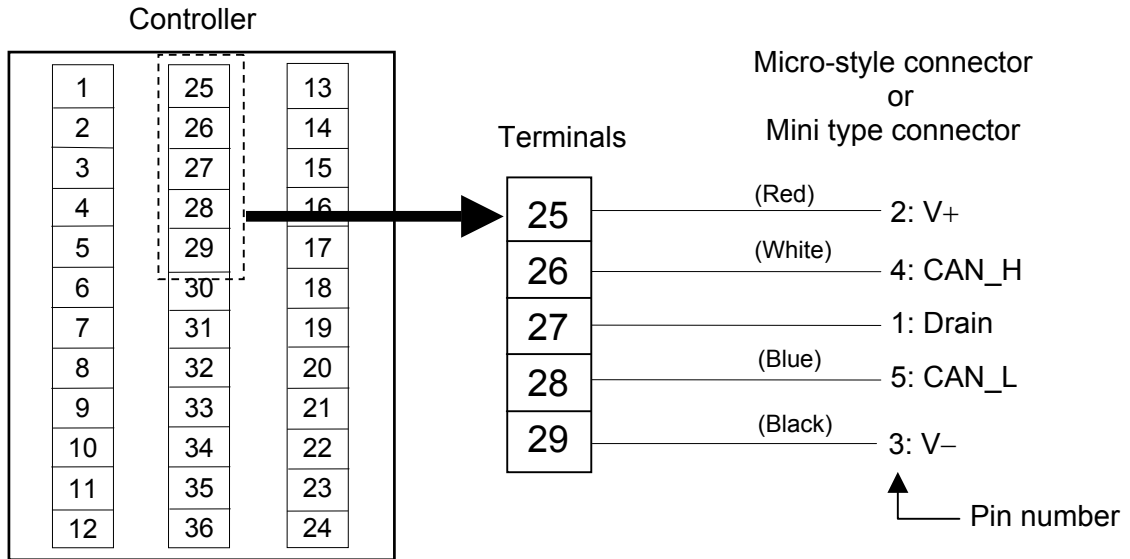

● **Connection socket (recommended model)**

SACC-M12FS-5CON-PG 9-M: PHOENIX CONTACT, Inc.

This socket is a type to use thin cable.

■ **Cable**

Use the specified DeviceNet communication cable (either thick cable or thin cable).

By thickness of a cable to use and connection method, usable connection connector type is different.

For cable specifications, connection method and vendor, refer to website of ODVA (Open DeviceNet Vender Association).
<http://www.odva.org>

4. SETTING

4.1 DeviceNet Setting

To identify each device connected to the network, it is necessary to set a different address to each device (node).



For the DeviceNet, as it is possible to connect up to 64 devices including a master to the network, node address (MAC ID) from 0 to 63 can be set.

- ☞ For details on relationship between communication speed and the length of the network, refer to **5.1 Features and Functionality (P. 11)**.

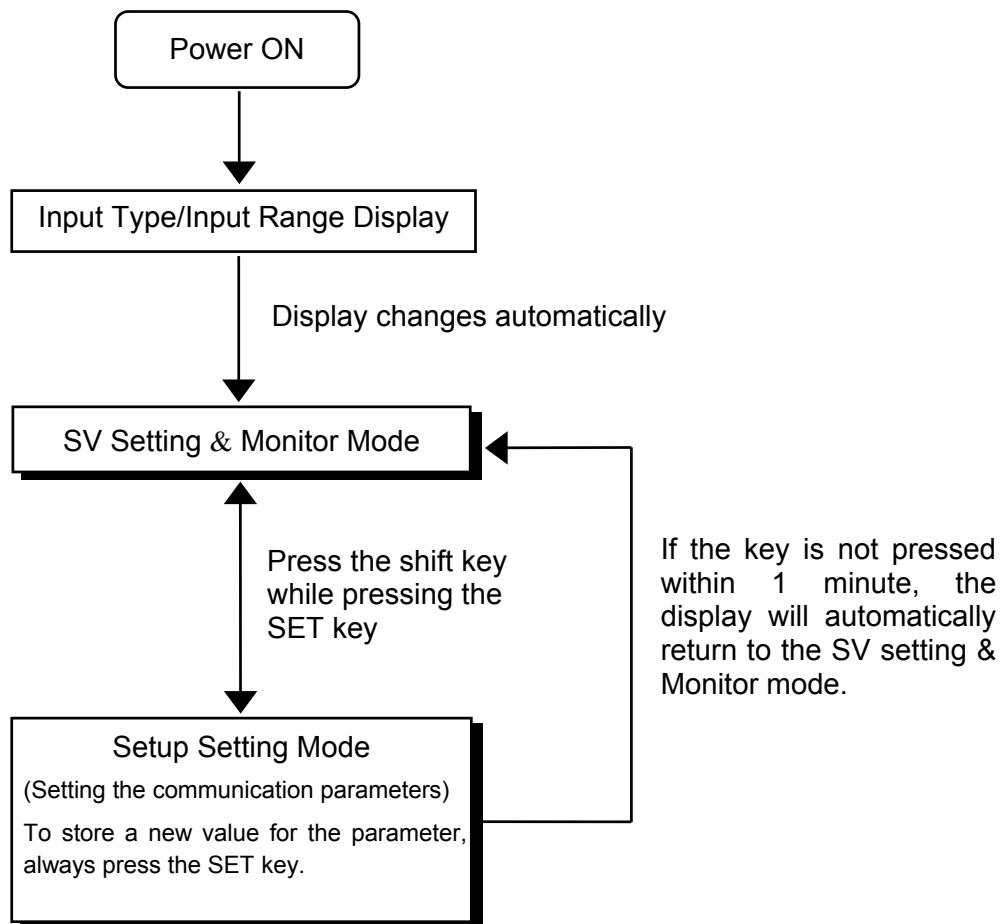
The controller node address (MAC ID) and DeviceNet communication speed are set in the Setup setting mode.





4.1.1 Transfer to setup setting mode

-  The first displayed parameter in the Setup setting mode varies depending on the instrument specification.
-  This section provides explanation, assuming that the first parameter in the Setup setting mode is PV bias (*Pb*).

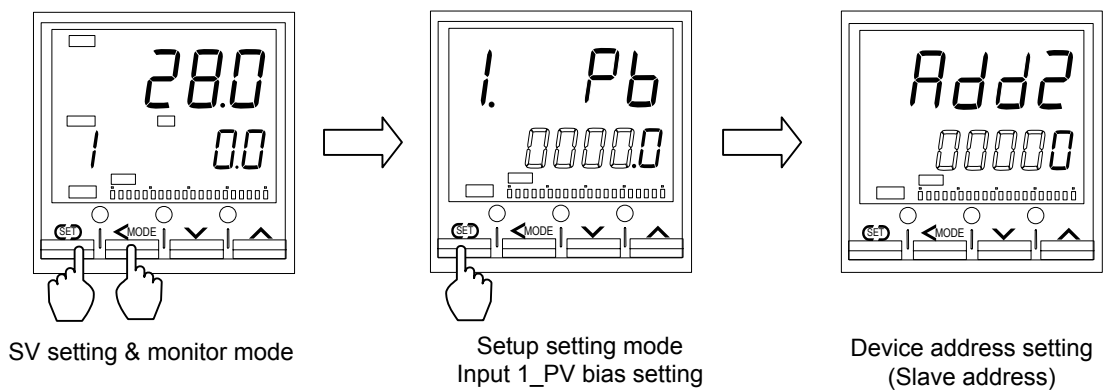
To enter the Setup setting mode, you must be in SV setting & Monitor mode. The first parameter to be displayed will be the Input 1_PV bias, *1. Pb*. Press the SET key several times to change to the device address 2, *Add2*.



-  To exit Setup setting mode, press the shift key while pressing the SET key. The display changes to the SV setting & Monitor mode.
-  HA930 is used in the above figures for explanation, but the same setting procedures also apply to HA430.

4.1.2 Node address and DeviceNet communication speed setting



This item describes when the communication (DeviceNet) is used under the 2-input controller.

To select parameters in the Setup setting mode, press the SET key.

The parameters relating to communication are shown below.

Device address; *Add2*,

Communication speed; *bPS2*

To be changed in the above order.

The node address (MAC ID) is set at Device address: “*Add2*”, while the DeviceNet communication speed is set at Communication speed: “*bPS2*.”

From Input 2_proportional cycle time screen

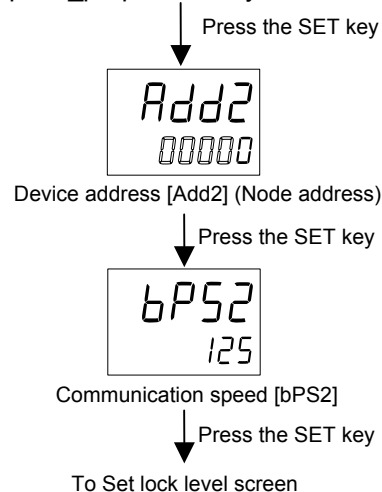

■ Setting procedure

Setting procedures vary depending on the communication parameter.

- Device address, *Add2* (Node address)
Operate UP, DOWN and shift key, and input numerals.
- Communication speed, *bPS*
Operate UP or DOWN key, and choose one among the displayed set value.

■ Store the set value

Press the SET key to store the new value.

After all communication parameters are set, in order to make these values thus set validate perform any of the following operations.

- The power is turned on again.
- The RUN/STOP mode is changed from STOP mode to RUN mode.

Continued on the next page.

Continued from the previous page.



A new value will not be stored without pressing SET key after the new value is displayed on the display. No communication using the value changed can be performed even with the SET key pressed.



When the RUN/STOP mode is changed from STOP mode to RUN mode, the controller performs the same operation as that of Power-on.



After a new value has been displayed by using the UP and DOWN keys, the SET key must be pressed within 1 minute, or the new value is not stored and the display will return to the PV1/SV1 monitor screen.



For the RUN/STOP transfer, refer to **HA430/HA930 Operation Manual (IMR01N12-E□)**.

■ Description of each parameters

● Communication

Symbol	Name	Setting range	Description	Factory set value
<i>Add2</i> (Add2)	Device address (Node address)	0 to 63	Do not use the same device address for more than one controller in multi-drop connection.	0
<i>bPS2</i> (bPS2)	Communication speed	125: 125 kbps 250: 250 kbps 500: 500 kbps	Set the same communication speed for both the controller (slave) and the host computer (master).	125

5. DeviceNet COMMUNICATIONS

5.1 Features and Functionality

- One DeviceNet Network can have a maximum of 64 Media Access Control Identifiers (MAC ID: Node address).
- Network length changes with communication speed.

Communication speed	Maximum network length *		Maximum drop length	Cumulative drop length
	Thick trunk length	Thin trunk length		
125 kbps	500 m	100 m	6 m	156 m or less
250 kbps	250 m			78 m or less
500 kbps	100 m			39 m or less

* Maximum distance between nodes

- Install terminating resistors to both ends of a trunk line in DeviceNet.
Specification of terminating resistor: 121 Ω, ±1 %, 1/4 W (Metal film resistance)
- A DeviceNet node is modeled as a collection of objects.
The object model provides a template for organizing and implementing the Attributes (data), Services and Behaviors of the components of a DeviceNet product.
This model has represented the construction of address designation to consist of four levels of Node address (MAC ID), Object class ID, Instance ID and Attribute ID.
An address of this 4 level is used as an identification factor of data in Explicit message communication.

Address	Lowest	Highest
Node	0	63
Object class	1	65535
Instance	0	65535
Attribute	1	255

- DeviceNet incorporates CAN (Controller Area Network). CAN defines the syntax or form of the data movement. Data on DeviceNet is transmitted using CAN data frame.

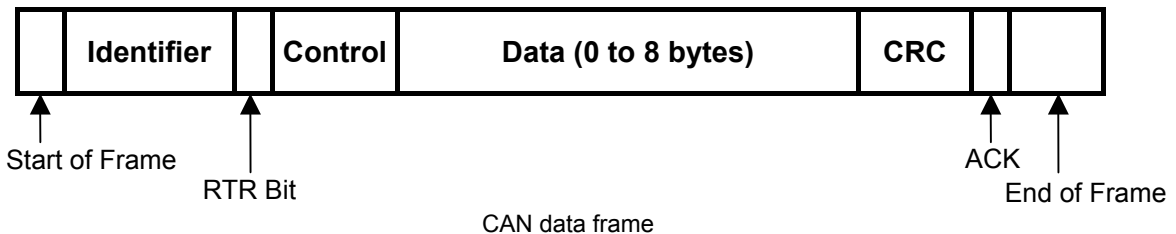

- 📖 For details on the communication specification of DeviceNet, refer to DeviceNet specifications. DeviceNet specifications are available from ODVA (Open DeviceNet Vendor Association). <http://www.odva.org>

5.2 Communication Method

The controller supports “Polling I/O communication” and “Explicit message communication” DeviceNet.

5.2.1 Polling I/O communication

Polling I/O communication is the communication that master and slave always execute transmission and reception of data. Used always when checking data items such as measured values, etc. The following data items are read by polling made once in polling I/O communication.

- Input 1_measured value (PV1)
- Input 1_manipulated output value (MV1)
- Input 1_set value (SV1) monitor
- Input 2_measured value (PV2)
- Input 2_manipulated output value (MV2)
- Input 2_set value (SV2) monitor
- Data item with ID number specified by the master
- Updated status *

* Any data item is available. The value is updated every time constant is re-written in the instrument.

If status, ID number and set value are sent from the master, the respective response data items are sent from the slave.

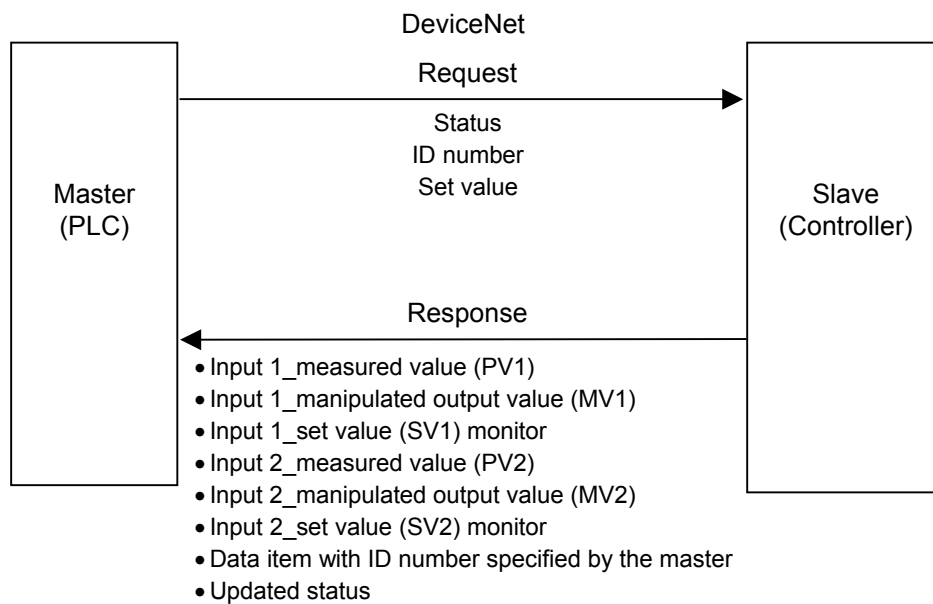

Outline of polling I/O communication



When setting the set value or monitoring the measured value in each channel of the controller, it is necessary to create on the master side a program which sends the data while selecting the data type, ID number * or set value sent from the master.



For data processed in actual communication, its decimal point is ignored. In addition, data with a minus sign is expressed as 2's complement data.

[Example 1]

For a set value of "10.0," set "100"

[Example 2]

For a set value of "-1," set "FFFFFFFFH"

■ Data to send from a master (request)

Corresponding object: Assembly object (0x04),

Object class ID: 4,

Instance ID: 2,

Attribute ID: 3

A master transmits data of the following for slave (Controller).

Attribute (data) contents

ID	Items	Data range
3	Status	When set value data is written into slave: 80H When data is read from slave: 00H
	ID number ¹	1 to 242
	Set value	Set value corresponding to communication item indicated by the ID number ²

¹ Attribute ID in the communication items list

² Set value corresponding to communication item indicated by ID number. It becomes invalid during status read.

■ **Data which a master receives (response)**

Corresponding object: Assembly object (0x04),

Object class ID: 4,

Instance ID: 1,

Attribute ID: 3

A master transmits data of the following for slave (Controller).

Attribute (data) contents

ID	Items
3	Input 1_measured value (PV1)
	Input 1_manipulated output value (MV1)
	Input 1_set value (SV1) monitor
	Input 2_measured value (PV2)
	Input 2_manipulated output value (MV2)
	Input 2_set value (SV2) monitor
	Set value corresponding to communication item specified by ID number
	Updated status *

* Any data item is available. The value is updated every time constant is re-written in the instrument.

5.2.2 Explicit message communication

Explicit message communication uses an Explicit message defined with DeviceNet, and be communication to execute transmission and reception of data between nodes when it is necessary. Explicit message communication is executed like the following, when Controller (slave) is connected to a master instrument with DeviceNet.



 In Explicit message communication, not only data relating to the controller bur also all of the attributes (data) described in **APPENDIX A. Device Profiles (P. 139)** are subject to being sent or received.

■ When read data

If the node address (MAC ID), service code (0EH: Get_Attribute_Single), object class ID, instance ID and attribute ID are sent from the master, the node address (MAC ID) thus sent and service code (0EH + 80H *) as well as the data requested are sent from the slave.

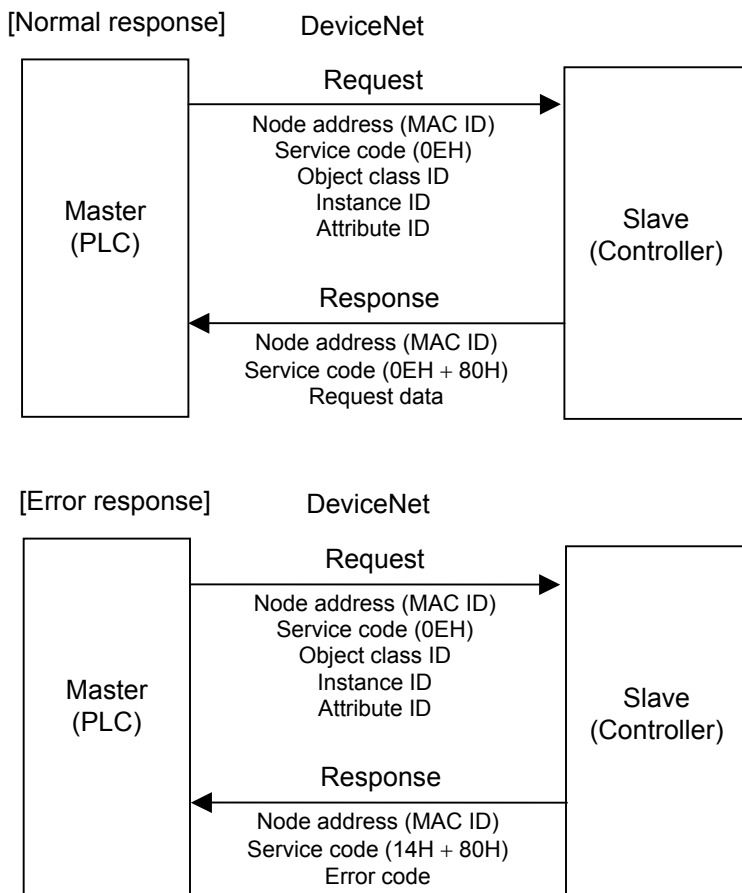
* 80H represents a response message.



 Service code 14H of [Error response] has shown that it is error response.
 For Error code of [Error response], refer to DeviceNet specifications.

■ When write data

If the node address (MAC ID), service code (10H: Set_Attribute_Single), object class ID, instance ID attribute ID and write data are sent from the master, the node address (MAC ID) thus sent and service code (10H + 80H *) are sent from the slave.

* 80H represents a response message.

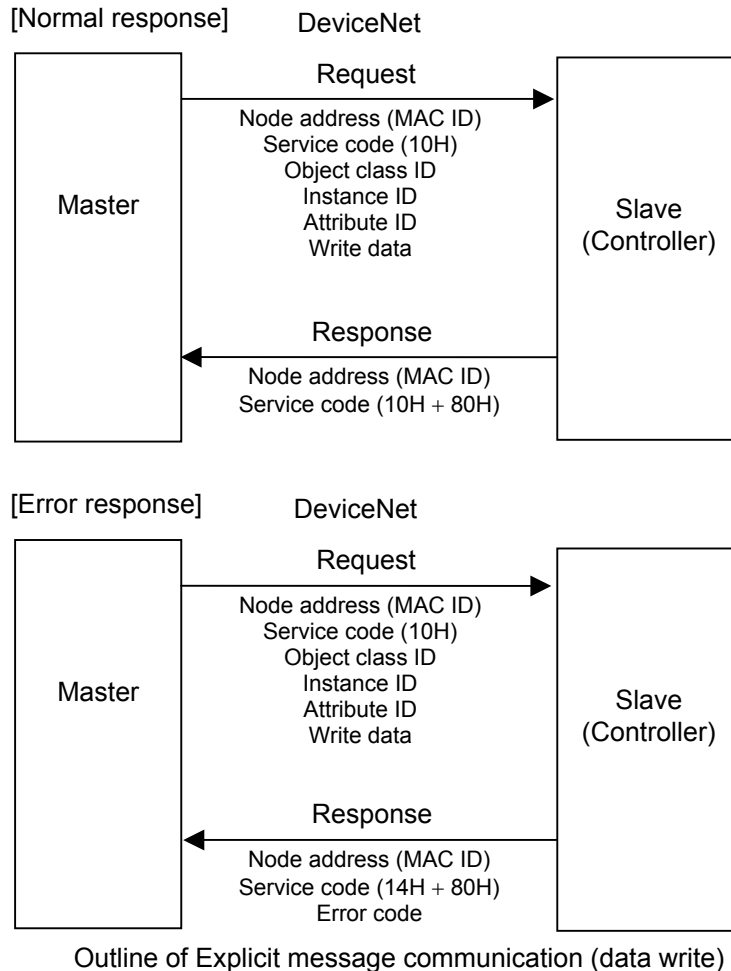

For data processed in actual communication, its decimal point is ignored. In addition, data with a minus sign is expressed as 2's complement data.

[Example 1] For a set value of "10.0," set "100"

[Example 2] For a set value of "-1," set "FFFFFFFFH"



Service code 14H of [Error response] has shown that it is error response.



For Error code of [Error response], refer to DeviceNet specifications.



For Explicit message communication specification of data relating to Controller, refer to **■ Controller object (0x64) (P. 146) of APPENDIX A. Device Profiles.**

■ Data setting example

Corresponding object: Controller object 1 (0x64),

Object class ID: 64,

Attribute ID: 1 to 242

[Example]**● When set in “10.0” in Input 1_set value (SV1)**

(Node address of Controller: 1)

Node address (MAC ID): 1

Service code: 10H (Set_Attribute_Single)

Object class ID: 64

Attribute ID: 40 (Input 1_set value (SV1))

Write data: 100

● When set in “5.0” in Input 2_proportional band.

(Node address of Controller: 1)

Node address (MAC ID): 1

Service code: 10H (Set_Attribute_Single)

Object class ID: 64

Attribute ID: 47 (Input 2_proportional band)

Write data: 50

5.3 Communication Items List



Attribute ID: Number which identifies controller data.
Attribute ID is written using both of decimal and hexadecimal (in parentheses) numbers.



Attribute : RO (Read only):
Correspond to Service code: 0EH (Get_Attribute_Single) of DeviceNet.
For data request of a master, data is read from slave.
R/W (Read and Write):
Correspond to Service code: 0EH (Get_Attribute_Single)/Service code: 10H (Set_Attribute_Single) of DeviceNet.
In Get_Attribute_Single, data is read for data request of a master from Slave.
In Set_Attribute_Single, write in data for Slave from a master.

Attribute ID	Name	Attribute	Data range	Factory set value	Reference page
1 (0x0001)	Input 1_measured value (PV1) monitor	RO	Input 1_input scale low to Input 1_input scale high	—	P. 40
2 (0x0002)	Input 2_measured value (PV2) monitor	RO	Input 2_input scale low to Input 2_input scale high	—	P. 40
3 (0x0003)	Unused	—	—	—	—
4 (0x0004)	Unused	—	—	—	—
5 (0x0005)	Unused	—	—	—	—
6 (0x0006)	Input 1_set value (SV1) monitor	RO	Input 1_setting limiter low to Input 1_setting limiter high	—	P. 40
7 (0x0007)	Input 2_set value (SV2) monitor	RO	Input 2_setting limiter low to Input 2_setting limiter high	—	P. 40
8 (0x0008)	Remote input value monitor	RO	Input 1_setting limiter low to Input 1_setting limiter high	—	P. 40
9 (0x0009)	Unused	—	—	—	—
10 (0x000A)	Input 1_burnout state	RO	0: OFF 1: ON	—	P. 41
11 (0x000B)	Input 2_burnout state	RO		—	P. 41
12 (0x000C)	Unused	—	—	—	—
13 (0x000D)	Event 1 state	RO	0: OFF 1: ON	—	P. 42
14 (0x000E)	Event 2 state	RO		—	P. 42

Continued on the next page.

Continued from the previous page.

Attribute ID	Name	Attribute	Data range	Factory set value	Reference page
15 (0x000F)	Event 3 state	RO	0: OFF 1: ON	—	P. 42
16 (0x0010)	Event 4 state	RO		—	P. 42
17 (0x0011)	Unused	—	—	—	—
18 (0x0012)	Unused	—	—	—	—
19 (0x0013)	Input 1_manipulated output value (MV1) monitor	RO	-5.0 to +105.0 %	—	P. 42
20 (0x0014)	Input 2_manipulated output value (MV2) monitor	RO		—	P. 42
21 (0x0015)	Error code	RO	Bit data Bit 0: Adjustment data error Bit 1: EEPROM error Bit 2: A/D conversion error Bit 3: RAM check error Bit 4: Hardware configuration error Bit 5: Software configuration error Bit 6: Unused Bit 7: Watchdog timer error Bit 8 to Bit 10: Unused Bit 11: Program busy Bit 12 to Bit 31: Unused Data 0: OFF 1: ON [Decimal number: 0 to 4095]	—	P. 43
22 (0x0016)	Event input (DI) state	RO	Bit data Bit 0: DI 1 state Bit 1: DI 2 state Bit 2: DI 3 state Bit 3: DI 4 state Bit 4: DI 5 state Bit 5 to Bit 31: Unused Data 0: Contact open 1: Contact closed [Decimal number: 0 to 31]	—	P. 44

Continued on the next page.

Continued from the previous page.

Attribute ID	Name	Attribute	Data range	Factory set value	Reference page
23 (0x0017)	Operation mode state	RO	Bit data Bit 0: Control STOP Bit 1: Control RUN Bit 2: Input 1_Manual mode (Including Input 1_Remote mode) Bit 3: Input 2_Manual mode (Including Input 2_Remote mode) Bit 4: Remote mode Bit 5 to Bit 31: Unused Data 0: OFF 1: ON [Decimal number: 0 to 31]	—	P. 45
24 (0x0018)	Memory area soak time monitor	RO	0 minute 00.00 second to 9 minutes 59.99 seconds or 0 hour 00 minute 00 second to 9 hours 59 minutes 59 seconds	—	P. 46
25 (0x0019)	Input 1_PID/AT transfer	R/W	0: PID control 1: Autotuning (AT) No PID/AT transfer is validated prior to factory shipment.	0	P. 46
26 (0x001A)	Input 2_PID/AT transfer	R/W	The transfer becomes validated only when “1: AT function (PI)” or “0: AT function (PID)” is selected in AT action selection.	0	P. 46
27 (0x001B)	Input 1_Auto/Manual transfer	R/W	0: Auto mode 1: Manual mode	1	P. 48
28 (0x001C)	Input 2_Auto/Manual transfer	R/W		1	P. 48
29 (0x001D)	Remote/Local transfer	R/W	0: Local mode 1: Remote mode	0	P. 48
30 (0x001E)	RUN/STOP transfer	R/W	0: Control RUN 1: Control STOP	0	P. 48
31 (0x001F)	Memory area selection	R/W	1 to 16	1	P. 49
32 (0x0020)	Event 1 set value	R/W	Deviation: –Input span to +Input span	50.0	P. 49
33 (0x0021)	Event 2 set value	R/W	Process/SV: Input scale low to Input scale high	50.0	P. 49
34 (0x0022)	Event 3 set value	R/W		50.0	P. 49
35 (0x0023)	Control loop break alarm 1 (LBA1) time	R/W	0 to 7200 seconds 0: OFF (Unused)	480	P. 50

Continued on the next page.

Continued from the previous page.

Attribute ID	Name	Attribute	Data range	Factory set value	Reference page
36 (0x0024)	LBA1 deadband	R/W	0 to Input span (Varies with the setting of the Decimal point position)	0.0	P. 50
37 (0x0025)	Event 4 set value	R/W	Deviation: –Input span to +Input span Process/SV: Input scale low to Input scale high	50.0	P. 49
38 (0x0026)	Control loop break alarm 2 (LBA2) time	R/W	0 to 7200 seconds 0: OFF (Unused)	480	P. 50
39 (0x0027)	LBA2 deadband	R/W	0 to Input span (Varies with the setting of the Decimal point position)	0.0	P. 50
40 (0x0028)	Input 1_set value (SV1)	R/W	Input 1_setting limiter low to Input 1_setting limiter high	0.0	P. 52
41 (0x0029)	Input 1_proportional band	R/W	0.0 to 1000.0 % of input span (0.0: ON/OFF action)	100.0	P. 53
42 (0x002A)	Input 1_integral time	R/W	0 to 3600 seconds, 0.0 to 3600.0 seconds or 0.00 to 360.00 seconds * (0, 0.0 or 0.00: PD action) * Varies with the setting of the Integral/Derivative time decimal point position selection.	5.00	P. 53
43 (0x002B)	Input 1_derivative time	R/W	0 to 3600 seconds, 0.0 to 3600.0 seconds or 0.00 to 360.00 seconds * (0, 0.0 or 0.00: PI action) * Varies with the setting of the Integral/Derivative time decimal point position selection.	0.00 (PI action)	P. 54
44 (0x002C)	Input 1_control response parameter	R/W	0: Slow 1: Medium 2: Fast	0	P. 54
45 (0x002D)	Unused	—	—	—	—
46 (0x002E)	Input 2_set value (SV2)	R/W	Input 2_setting limiter low to Input 2_setting limiter high	0.0	P. 52
47 (0x002F)	Input 2_proportional band	R/W	TC/RTD inputs: 0 (0.0 or 0.00) to Input span (Unit: °C [°F]) Voltage/Current inputs: 0.0 to 1000.0 % of input span (0, 0.0 or 0.00: ON/OFF action)	30.0	P. 53

Continued on the next page.

Continued from the previous page.

Attribute ID	Name	Attribute	Data range	Factory set value	Reference page
48 (0x0030)	Input 2_integral time	R/W	0 to 3600 seconds, 0.0 to 3600.0 seconds or 0.00 to 360.00 seconds * (0, 0.0 or 0.00: PD action) * Varies with the setting of the Integral/Derivative time decimal point position selection.	240.00	P. 53
49 (0x0031)	Input 2_derivative time	R/W	0 to 3600 seconds, 0.0 to 3600.0 seconds or 0.00 to 360.00 seconds * (0, 0.0 or 0.00: PI action) * Varies with the setting of the Integral/Derivative time decimal point position selection.	60.00	P. 54
50 (0x0032)	Input 2_control response parameter	R/W	0: Slow 1: Medium 2: Fast	0	P. 54
51 (0x0033)	Unused	—	—	—	—
52 (0x0034)	Input 1_setting change rate limiter (up)	R/W	0 to Input span/unit time * 0: OFF (Unused)	0.0	P. 55
53 (0x0035)	Input 1_setting change rate limiter (down)	R/W	(Varies with the setting of the Decimal point position)	0.0	P. 55
54 (0x0036)	Input 2_setting change rate limiter (up)	R/W	* Unit time: 60 seconds (factory set value)	0.0	P. 55
55 (0x0037)	Input 2_setting change rate limiter (down)	R/W		0.0	P. 55
56 (0x0038)	Area soak time	R/W	0 minute 00.00 second to 9 minutes 59.99 seconds or 0 hour 00 minute 00 second to 9 hours 59 minutes 59 seconds	0.00.00	P. 57
57 (0x0039)	Link area number	R/W	0 to 16 0: OFF (No link)	0	P. 58
58 (0x003A)	Unused	—	—	—	—
59 (0x003B)	Unused	—	—	—	—
60 (0x003C)	Input 1_PV bias	R/W	–Input span to +Input span	0	P. 59
61 (0x003D)	Input 1_PV digital filter	R/W	0.00 to 10.00 seconds 0.00: OFF (Unused)	0.00	P. 59

Continued on the next page.

Continued from the previous page.

Attribute ID	Name	Attribute	Data range	Factory set value	Reference page
62 (0x003E)	Input 1_PV ratio	R/W	0.500 to 1.500	1.000	P. 60
63 (0x003F)	Input 1_PV low input cut-off	R/W	0.00 to 25.00 % of input span	0.00	P. 61
64 (0x0040)	Input 1_proportional cycle time	R/W	0.1 to 100.0 seconds	Relay contact output: 20.0 seconds Voltage pulse output and triac output: 2.0 seconds	P. 62
65 (0x0041)	Input 1_manual output value	R/W	MV scaling low to MV scaling high	0	P. 62
66 (0x0042)	Input 2_PV bias	R/W	-Input span to +Input span	0	P. 59
67 (0x0043)	Input 2_PV digital filter	R/W	0.00 to 10.00 seconds 0.00: OFF (Unused)	0.00	P. 59
68 (0x0044)	Input 2_PV ratio	R/W	0.500 to 1.500	1.000	P. 60
69 (0x0045)	Input 2_PV low input cut-off	R/W	0.00 to 25.00 % of input span	0.00	P. 61
70 (0x0046)	Input 2_proportional cycle time	R/W	0.1 to 100.0 seconds	Relay contact output: 20.0 seconds Voltage pulse output and triac output: 2.0 seconds	P. 62
71 (0x0047)	Input 2_manual output value	R/W	Input 2_output limiter low to Input 2_output limiter high	0.0	P. 62
72 (0x0048)	Set lock level	R/W	Bit data Bit 0: Lock only setting items other than SV and events (EV1 to EV4). Bit 1: Lock only events (EV1 to EV4). Bit 2: Lock only set value (SV). Bit 3 to Bit 31: Unused Data 0: Unlock 1: Lock [Decimal number: 0 to 7]	0	P. 63
73 (0x0049)	EEPROM storage state	RO	0: The content of the EEPROM does not coincide with that of the RAM. 1: The content of the EEPROM coincides with that of the RAM.	—	P. 64

Continued on the next page.

Continued from the previous page.

Attribute ID	Name	Attribute	Data range	Factory set value	Reference page
74 (0x004A)	EEPROM storage mode	R/W	0: Set values are store to the EEPROM when set values are changed. 1: Not set values are store to the EEPROM when set values are changed.	0	P. 64
75 (0x004B)	Unused	—	—	—	—
76 (0x004C)	Unused	—	—	—	—
77 (0x004D)	Unused	—	—	—	—
78 (0x004E)	Unused	—	—	—	—
79 (0x004F)	PV1 peak hold value monitor	RO	Input 1_input scale low to Input 1_input scale high Displays the maximum PV of Input 1.	—	P. 65
80 (0x0050)	PV1 bottom hold value monitor	RO	Input 1_input scale low to Input 1_input scale high Displays the minimum PV of Input 1.	—	P. 66
81 (0x0051)	PV1 hold reset	R/W	0, 1 0: Hold reset execution If 0 is written, the hold value is reset to return to 1. The polling of “1” is always made.	1	P. 67
82 (0x0052)	PV2 peak hold value monitor	RO	Input 2_input scale low to Input 2_input scale high Displays the maximum PV of Input 2.	—	P. 65
83 (0x0053)	PV2 bottom hold value monitor	RO	Input 2_input scale low to Input 2_input scale high Displays the minimum PV of Input 2.	—	P. 66
84 (0x0054)	PV2 hold reset	R/W	0, 1 0: Hold reset execution If 0 is written, the hold value is reset to return to 1. The polling of “1” is always made.	1	P. 67
85 (0x0055)	Interlock release	R/W	0, 1 0: Interlock release execution If 0 is written, the interlock is released.	1	P. 67

Continued on the next page.

Continued from the previous page.

Attribute ID	Name	Attribute	Data range	Factory set value	Reference page
86 (0x0056)	Auto-zero (Input 1)	R/W	0, 1, 3 1: Zero point adjustment execution Writing "1" starts zero point adjustment, and then "1" returns to "0" after the adjustment is finished. 3: Adjustment error Writing "0" returns to a normal state. Relevant pressure sensors: CZ-100P, CZ-200P	0	P. 68
87 (0x0057)	Auto calibration (Input 1)	R/W	0 to 3 1: Auto calibration execution Writing "1" starts auto calibration, and it changes to "2" during the adjustment and returns to "0" after the adjustment is finished. 3: Adjustment error Writing "0" returns to a normal state.	0	P. 68
88 (0x0058) ⋮ 99 (0x0063)	Unused	—	—	—	—
100 (0x0064)	STOP display selection	R/W	0: Displays on the measured value (PV1/PV2) unit 1: Displays on the Set value (SV) unit	0	P. 69
101 (0x0065)	Bar graph display selection	R/W	0: No display 1: Input 1_manipulated output value (MV) 2: Input 1_measured value (PV) 3: Input 1_set value (SV) 4: Input 1_deviation value 5: Unused (Not available) 6: Input 2_manipulated output value (MV) 7: Input 2_measured value (PV) 8: Input 2_set value (SV) 9: Input 2_deviation value	0	P. 69
102 (0x0066)	Bar graph resolution setting	R/W	1 to 100 digit/dot	100	P. 70
103 (0x0067)	Unused	—	—	—	—

Continued on the next page.

Continued from the previous page.

Attribute ID	Name	Attribute	Data range	Factory set value	Reference page
104 (0x0068)	Auto/Manual transfer key operation selection (A/M)	R/W	0: Unused 1: Auto/Manual transfer for input 1 2: Auto/Manual transfer for input 2 3: Auto/Manual transfer for input 1 and input 2	3	P. 71
105 (0x0069)	Remote/Local transfer key operation selection (R/L)	R/W	0: Unused 1: Remote/Local transfer	1	P. 71
106 (0x006A)	RUN/STOP transfer key operation selection (R/S)	R/W	0: Unused 1: RUN/STOP transfer	1	P. 71
107 (0x006B)	Input 1_input type selection	R/W	Voltage (V)/Current (I) inputs -19999 to +99999 14: 0 to 20 mA DC 24: ±100 mV DC 15: 4 to 20 mA DC 25: ±10 mV DC 16: 0 to 10 V DC 26: ±10 V DC 17: 0 to 5 V DC 27: ±5 V DC 18: 1 to 5 V DC 28: ±1 V DC 19: 0 to 1 V DC 20: 0 to 100 mV DC 21: 0 to 10 mV DC Pressure sensor input 0.0 to 250.0 MPa 29: Resin pressure sensor Relevant pressure sensors: CZ-100P, CZ-200P 22, 23: Unused (Not available)	Based on model code. When not specifying: Pressure sensor input	P. 72
108 (0x006C)	Input 1_display unit selection	R/W	2: MPa 3: bar 4: kgf/cm ² 5: psi The display unit selection becomes invalidated when the Voltage (V) /Current (I) input is selected as input type.	Pressure sensor input: 2 V/I: 0	P. 73
109 (0x006D)	Input 1_decimal point position	R/W	0: No decimal place 1: One decimal place 2: Two decimal places 3: Three decimal places 4: Four decimal places * Less than 1 MPa: Decimal point position 0 to 4 Less than 10 MPa: Decimal point position 0 to 3 Less than 100 MPa: Decimal point position 0 to 2 100 MPa or more: Decimal point position 0 or 1 Voltage (V)/current (I) inputs: Decimal point position 0 to 4	1	P. 74

Continued on the next page.

Continued from the previous page.

Attribute ID	Name	Attribute	Data range	Factory set value	Reference page
110 (0x006E)	Input 1_input scale high	R/W	Pressure sensor input: Input scale low to Maximum value of the selected input range Voltage (V)/Current (I) inputs: –19999 to +99999 (Varies with the setting of the Decimal point position)	Pressure sensor input: 50.0 V/I: 100.0	P. 75
111 (0x006F)	Input 1_input scale low	R/W	Pressure sensor input: Minimum value of the selected input range to Input scale high Voltage (V)/Current (I) inputs: –19999 to +99999 (Varies with the setting of the Decimal point position)	Pressure sensor input: 0.0 V/I: 0.0	P. 76
112 (0x0070)	Input 1_input error determination point (high)	R/W	Input scale low – (5 % of input span) to Input scale high + (5 % of input span)	Pressure sensor input: Input scale high + (5 % of input span) V/I: 105.0	P. 77
113 (0x0071)	Input 1_input error determination point (low)	R/W		Pressure sensor input: Input scale low – (5 % of input span) V/I: –5.0	P. 78
114 (0x0072)	Input 1_ burnout direction	R/W	0: Upscale 1: Downscale	0	P. 79
115 (0x0073)	Input 1_square root extraction selection	R/W	0: Unused 1: Used	0	P. 80
116 (0x0074)	Power supply frequency selection	R/W	0: 50 Hz 1: 60 Hz	0	P. 80
117 (0x0075)	Input 2_input type selection	R/W	TC input 0: K –200 to +1372 °C –328.0 to +2501.6 °F 1: J –200 to +1200 °C –328.0 to +2192.0 °F 2: R –50 to +1768 °C –58.0 to +3214.4 °F 3: S –50 to +1768 °C –58.0 to +3214.4 °F 4: B 0 to 1800 °C 32.0 to 3272.0 °F 5: E –200 to +1000 °C –328.0 to +1832.0 °F 6: N 0 to 1300 °C 32.0 to 2372.0 °F 7: T –200 to +400 °C –328.0 to +752.0 °F	Based on model code. When not specifying: Type K	P. 72

Continued on the next page.

Continued from the previous page.

Attribute ID	Name	Attribute	Data range	Factory set value	Reference page
117 (0x0075)	Input 2_input type selection	R/W	TC input 8: W5Re/W26Re 0 to 2300 °C 32.0 to 4172.0 °F 9: PLII 0 to 1390 °C 32.0 to 2534.0 °F RTD input (3-wire system) 12: Pt100 -200 to +850 °C -328.0 to +1562.0 °F 13: JPt100 -200 to +600 °C -328.0 to +1112.0 °F Voltage (V)/Current (I) inputs -19999 to +99999 14: 0 to 20 mA DC 24: ±100 mV DC 15: 4 to 20 mA DC 25: ±10 mV DC 16: 0 to 10 V DC 26: ±10 V DC 17: 0 to 5 V DC 27: ±5 V DC 18: 1 to 5 V DC 28: ±1 V DC 19: 0 to 1 V DC 20: 0 to 100 mV DC 21: 0 to 10 mV DC 22, 23: Unused (Not available)	Based on model code. When not specifying: Type K	P. 72
118 (0x0076)	Input 2_ display unit selection	R/W	0: °C 1: °F The display unit selection becomes invalidated when the Voltage (V) /Current (I) input is selected as input type.	0	P. 73
119 (0x0077)	Input 2_ decimal point position	R/W	0: No decimal place 1: One decimal place 2: Two decimal places 3: Three decimal places 4: Four decimal places	1	P. 74
120 (0x0078)	Input 2_input scale high	R/W	TC/RTD inputs: Input scale low to Maximum value of the selected input range Voltage (V)/Current (I) inputs: -19999 to +99999 (Varies with the setting of the Decimal point position)	TC/RTD: Maximum value of the selected input range V/I: 100.0	P. 75

Continued on the next page.

Continued from the previous page.

Attribute ID	Name	Attribute	Data range	Factory set value	Reference page
121 (0x0079)	Input 2_input scale low	R/W	TC/RTD inputs: Minimum value of the selected input range to Input scale high Voltage (V)/Current (I) inputs: -19999 to +99999 (Varies with the setting of the Decimal point position)	TC/RTD: Minimum value of the selected input range V/I: 0.0	P. 76
122 (0x007A)	Input 2_input error determination point (high)	R/W	Input scale low – (5 % of input span) to Input scale high + (5 % of input span)	TC/RTD: Input scale high + (5 % of input span) V/I: 105.0	P. 77
123 (0x007B)	Input 2_input error determination point (low)	R/W		TC/RTD: Input scale low – (5 % of input span) V/I: -5.0	P. 78
124 (0x007C)	Input 2_burnout direction	R/W	0: Upscale 1: Downscale	0	P. 79
125 (0x007D)	Input 2_square root extraction selection	R/W	0: Unused 1: Used	0	P. 80
126 (0x007E)	Event input logic selection	R/W	0 to 15	1	P. 81
127 (0x007F)	Output logic selection	R/W	3 to 8, 11 1, 2, 9 and 10: Unused (Not available)	1-input controller: 3 2-input controller: 5	P. 84
128 (0x0080)	Output 1 timer setting	R/W	0.0 to 600.0 seconds	0.0	P. 86
129 (0x0081)	Output 2 timer setting	R/W		0.0	P. 86
130 (0x0082)	Output 3 timer setting	R/W		0.0	P. 86
131 (0x0083)	Output 4 timer setting	R/W		0.0	P. 86
132 (0x0084)	Output 5 timer setting	R/W		0.0	P. 86
133 (0x0085)	Transmission output 1_type selection	R/W		0: None 1: Input 1_measured value (PV) 2: Input 1_set value (SV) 3: Input 1_deviation value 4: Input 1_manipulated output value (MV) 5: Input 2_measured value (PV) 6: Input 2_set value (SV) 7: Input 2_deviation value 8: Input 2_manipulated output value (MV) 9: Unused (Not available)	0

Continued on the next page.

Continued from the previous page.

Attribute ID	Name	Attribute	Data range	Factory set value	Reference page
134 (0x0086)	Transmission output 1_ scale high	R/W	Measured value (PV) and Set value (SV): Input scale low to Input scale high Manipulated output value (MV): -5.0 to +105.0 %	PV/SV: Input scale high MV: 100.0 Deviation: +Input span	P. 88
135 (0x0087)	Transmission output 1_ scale low	R/W	Deviation: -Input span to +Input span	PV/SV: Input scale low MV: 0.0 Deviation: -Input span	P. 88
136 (0x0088)	Transmission output 2_ type selection	R/W	0: None 1: Input 1_measured value (PV) 2: Input 1_set value (SV) 3: Input 1_deviation value 4: Input 1_manipulated output value (MV) 5: Input 2_measured value (PV) 6: Input 2_set value (SV) 7: Input 2_deviation value 8: Input 2_manipulated output value (MV) 9: Unused (Not available)	0	P. 87
137 (0x0089)	Transmission output 2_ scale high	R/W	Measured value (PV) and Set value (SV): Input scale low to Input scale high Manipulated output value (MV): -5.0 to +105.0 %	PV/SV: Input scale high MV: 100.0 Deviation: +Input span	P. 88
138 (0x008A)	Transmission output 2_ scale low	R/W	Deviation: -Input span to +Input span	PV/SV: Input scale low MV: 0.0 Deviation: -Input span	P. 88
139 (0x008B)	Transmission output 3_ type selection	R/W	0: None 1: Input 1_measured value (PV) 2: Input 1_set value (SV) 3: Input 1_deviation value 4: Input 1_manipulated output value (MV) 5: Input 2_measured value (PV) 6: Input 2_set value (SV) 7: Input 2_deviation value 8: Input 2_manipulated output value (MV) 9: Unused (Not available)	0	P. 87

Continued on the next page.

Continued from the previous page.

Attribute ID	Name	Attribute	Data range	Factory set value	Reference page
140 (0x008C)	Transmission output 3_ scale high	R/W	Measured value (PV) and Set value (SV): Input scale low to Input scale high Manipulated output value (MV): -5.0 to +105.0 %	PV/SV: Input scale high MV: 100.0 Deviation: +Input span	P. 88
141 (0x008D)	Transmission output 3_ scale low	R/W	Deviation: -Input span to +Input span	PV/SV: Input scale low MV: 0.0 Deviation: -Input span	P. 88
142 (0x008E)	Event 1 type selection	R/W	0: None 1: Deviation high 2: Deviation low 3: Deviation high/low 4: Band 5: Process high 6: Process low 7: SV high 8: SV low	0	P. 89
143 (0x008F)	Event 1 hold action	R/W	0: OFF 1: ON 2: Re-hold action ON	0	P. 91
144 (0x0090)	Event 1 differential gap	R/W	0 to Input span (Varies with the setting of the Decimal point position)	Pressure sensor input: 2.0 MPa TC/RTD: 2.0 °C [°F] V/I: 0.2 % of input span	P. 93
145 (0x0091)	Event 1 action at input error	R/W	0: Normal processing 1: Turn the event output ON	0	P. 94
146 (0x0092)	Event 1 assignment	R/W	1: For input 1 2: For input 2	1	P. 95
147 (0x0093)	Event 2 type selection	R/W	0: None 1: Deviation high 2: Deviation low 3: Deviation high/low 4: Band 5: Process high 6: Process low 7: SV high 8: SV low	0	P. 89

Continued on the next page.

Continued from the previous page.

Attribute ID	Name	Attribute	Data range	Factory set value	Reference page
148 (0x0094)	Event 2 hold action	R/W	0: OFF 1: ON 2: Re-hold action ON	0	P. 91
149 (0x0095)	Event 2 differential gap	R/W	0 to Input span (Varies with the setting of the Decimal point position)	Pressure sensor input: 2.0 MPa TC/RTD: 2.0 °C [°F] V/I: 0.2 % of input span	P. 93
150 (0x0096)	Event 2 action at input error	R/W	0: Normal processing 1: Turn the event output ON	0	P. 94
151 (0x0097)	Event 2 assignment	R/W	1: For input 1 2: For input 2	1	P. 95
152 (0x0098)	Event 3 type selection	R/W	0: None 1: Deviation high 2: Deviation low 3: Deviation high/low 4: Band 5: Process high 6: Process low 7: SV high 8: SV low 9: Control loop break alarm (LBA)	0	P. 89
153 (0x0099)	Event 3 hold action	R/W	0: OFF 1: ON 2: Re-hold action ON	0	P. 91
154 (0x009A)	Event 3 differential gap	R/W	0 to Input span (Varies with the setting of the Decimal point position)	Pressure sensor input: 2.0 MPa TC/RTD: 2.0 °C [°F] V/I: 0.2 % of input span	P. 93
155 (0x009B)	Event 3 action at input error	R/W	0: Normal processing 1: Turn the event output ON	0	P. 94
156 (0x009C)	Event 3 assignment	R/W	1: For input 1 2: For input 2	1	P. 95
157 (0x009D)	Event 4 type selection	R/W	0: None 1: Deviation high 2: Deviation low 3: Deviation high/low 4: Band 5: Process high 6: Process low 7: SV high 8: SV low 9: Control loop break alarm (LBA)	0	P. 89

Continued on the next page.

Continued from the previous page.

Attribute ID	Name	Attribute	Data range	Factory set value	Reference page
158 (0x009E)	Event 4 hold action	R/W	0: OFF 1: ON 2: Re-hold action ON	0	P. 91
159 (0x009F)	Event 4 differential gap	R/W	0 to Input span (Varies with the setting of the Decimal point position)	Pressure sensor input: 2.0 MPa TC/RTD: 2.0 °C [°F] V/I: 0.2 % of input span	P. 93
160 (0x00A0)	Event 4 action at input error	R/W	0: Normal processing 1: Turn the event output ON	0	P. 94
161 (0x00A1)	Event 4 assignment	R/W	1: For input 1 2: For input 2	1	P. 95
162 (0x00A2)	Unused	—	—	—	—
163 (0x00A3)	Unused	—	—	—	—
164 (0x00A4)	Unused	—	—	—	—
165 (0x00A5)	Unused	—	—	—	—
166 (0x00A6)	Hot/Cold start selection	R/W	Power failure less than 3 seconds: 0: Hot 1 5: Cold 1: Hot 1 6: Hot 1 2: Hot 1 7: Hot 2 3: Hot 2 8: Stop 4: Hot 2 Power failure 3 seconds or more: 0: Hot 1 5: Cold 1: Hot 2 6: Stop 2: Cold 7: Stop 3: Hot 2 8: Stop 4: Cold	5	P. 95
167 (0x00A7)	Input 2_use selection	R/W	0: Single loop control 1: Remote input	0	P. 96
168 (0x00A8)	Unused	—	—	—	—
169 (0x00A9)	Unused	—	—	—	—
170 (0x00AA)	SV tracking	R/W	0: Unused 1: Used	1	P. 96
171 (0x00AB)	Input 1_control action type selection	R/W	0: Direct action 1: Reverse action	1	P. 97

Continued on the next page.

Continued from the previous page.

Attribute ID	Name	Attribute	Data range	Factory set value	Reference page
172 (0x00AC)	Input 1_integral/derivative time decimal point position selection	R/W	0: No decimal place 1: One decimal place 2: Two decimal places	2	P. 98
173 (0x00AD)	Input 1_derivative gain	R/W	0.1 to 10.0	6.0	P. 98
174 (0x00AE)	Input 1_ON/OFF action differential gap (upper)	R/W	0 to Input span (Varies with the setting of the Decimal point position)	Pressure sensor input: 1.0 MPa V/I: 0.1 % of input span	P. 99
175 (0x00AF)	Input 1_ON/OFF action differential gap (lower)	R/W		Pressure sensor input: 1.0 MPa V/I: 0.1 % of input span	P. 100
176 (0x00B0)	Input 1_action at input error (high)	R/W	0: Normal control 1: Manipulated output value at input error	0	P. 101
177 (0x00B1)	Input 1_action at input error (low)	R/W		0	P. 102
178 (0x00B2)	Input 1_manipulated output value at input error	R/W	-5.0 to +105.0 %	-5.0	P. 102
179 (0x00B3)	Input 1_output change rate limiter (up)	R/W	0.0 to 1000.0 %/second of manipulated output 0.0: OFF (Unused)	0.0	P. 103
180 (0x00B4)	Input 1_output change rate limiter (down)	R/W		0.0	P. 103
181 (0x00B5)	Input 1_output limiter high	R/W	Input 1_output limiter low to 105.0 %	105.0	P. 105
182 (0x00B6)	Input 1_output limiter low	R/W	-5.0 % to Input 1_output limiter high	-5.0	P. 105
183 (0x00B7)	Unused	—	—	—	—
184 (0x00B8)	Input 2_control action type selection	R/W	0: Direct action 1: Reverse action	1	P. 97
185 (0x00B9)	Input 2_integral/derivative time decimal point position selection	R/W	0: No decimal place 1: One decimal place 2: Two decimal places	2	P. 98
186 (0x00BA)	Input 2_derivative gain	R/W	0.1 to 10.0	6.0	P. 98
187 (0x00BB)	Input 2_ON/OFF action differential gap (upper)	R/W	0 to Input span (Varies with the setting of the Decimal point position)	TC/RTD: 1.0 °C [°F] V/I: 0.1 % of input span	P. 99
188 (0x00BC)	Input 2_ON/OFF action differential gap (lower)	R/W		TC/RTD: 1.0 °C [°F] V/I: 0.1 % of input span	P. 100

Continued on the next page.

Continued from the previous page.

Attribute ID	Name	Attribute	Data range	Factory set value	Reference page
189 (0x00BD)	Input 2_ action at input error (high)	R/W	0: Normal control 1: Manipulated output value at input error	0	P. 101
190 (0x00BE)	Input 2_ action at input error (low)	R/W		0	P. 102
191 (0x00BF)	Input 2_manipulated output value at input error	R/W	-5.0 to +105.0 %	-5.0	P. 102
192 (0x00C0)	Input 2_output change rate limiter (up)	R/W	0.0 to 1000.0 %/second of manipulated output 0.0: OFF (Unused)	0.0	P. 103
193 (0x00C1)	Input 2_output change rate limiter (down)	R/W		0.0	P. 103
194 (0x00C2)	Input 2_output limiter high	R/W	Input 2_output limiter low to 105.0 %	105.0	P. 105
195 (0x00C3)	Input 2_output limiter low	R/W	-5.0 % to Input 2_output limiter high	-5.0	P. 105
196 (0x00C4)	Unused	—	—	—	—
197 (0x00C5)	Input 1_AT bias	R/W	-Input span to +Input span	0	P. 106
198 (0x00C6)	Input 1_AT cycle	R/W	0: 1.5 cycles 1: 2.0 cycles 2: 2.5 cycles 3: 3.0 cycles	1	P. 107
199 (0x00C7)	Input 1_ AT differential gap time	R/W	0.00 to 50.00 seconds	0.10	P. 108
200 (0x00C8)	Input 2_AT bias	R/W	-Input span to +Input span	0	P. 106
201 (0x00C9)	Input 2_AT cycle	R/W	0: 1.5 cycles 1: 2.0 cycles 2: 2.5 cycles 3: 3.0 cycles	1	P. 107
202 (0x00CA)	Input 2_ AT differential gap time	R/W	0.00 to 50.00 seconds	0.10	P. 108
203 (0x00CB)	Unused	—	—	—	—
204 (0x00CC)	Unused	—	—	—	—
205 (0x00CD)	Unused	—	—	—	—
206 (0x00CE)	Unused	—	—	—	—

Continued on the next page.

Continued from the previous page.

Attribute ID	Name	Attribute	Data range	Factory set value	Reference page
207 (0x00CF)	Setting change rate limiter unit time	R/W	1 to 3600 seconds	60	P. 109
208 (0x00D0)	Soak time unit selection	R/W	0: 0 hour 00 minutes 00 seconds to 9 hours 59 minutes 59 seconds 2: 0 minutes 00.00 seconds to 9 minutes 59.99 seconds	2	P. 109
209 (0x00D1)	Input 1_setting limiter high	R/W	Input 1_setting limiter low to Input 1_input scale high	Input 1_input scale high	P. 110
210 (0x00D2)	Input 1_setting limiter low	R/W	Input 1_input scale low to Input 1_setting limiter high	Input 1_input scale low	P. 110
211 (0x00D3)	Input 2_setting limiter high	R/W	Input 2_setting limiter low to Input 2_input scale high	Input 2_input scale high	P. 110
212 (0x00D4)	Input 2_setting limiter low	R/W	Input 2_input scale low to Input 2_setting limiter high	Input 2_input scale low	P. 110
213 (0x00D5)	ROM version display	RO	Displays the version of loaded software.	—	P. 111
214 (0x00D6)	Integrated operating time display	RO	0 to 99999 hours	—	P. 111
215 (0x00D7)	Holding peak value ambient temperature display	RO	-10.0 to +100.0 °C (14.0 to 212.0 °F)	—	P. 111
216 (0x00D8)	Unused	—	—	—	—
217 (0x00D9)	Unused	—	—	—	—
218 (0x00DA)	Unused	—	—	—	—
219 (0x00DB)	Unused	—	—	—	—
220 (0x00DC)	Unused	—	—	—	—
221 (0x00DD)	Unused	—	—	—	—
222 (0x00DE)	Unused	—	—	—	—
223 (0x00DF)	Unused	—	—	—	—

Continued on the next page.

Continued from the previous page.

Attribute ID	Name	Attribute	Data range	Factory set value	Reference page
224 (0x00E0)	Alarm lamp lighting condition setting	R/W	Bit data Bit 0: Event 1 Bit 1: Event 2 Bit 2: Event 3 Bit 3: Event 4 Bit 4 to Bit 31: Unused Data 0: ALM lamp is not lit 1: ALM lamp is lit [Decimal number: 0 to 15]	15	P. 112
225 (0x00E1)	Unused	—	—	—	—
226 (0x00E2)	Input 1_PV1 hold function	R/W	0: Unused 1: Used	0	P. 113
227 (0x00E3)	Input 2_PV2 hold function	R/W		0	P. 113
228 (0x00E4)	Gain setting (Input 1)	R/W	0.500 to 4.000 mV/V Relevant pressure sensors: CZ-100P or CZ-200P	CZ-100P/ CZ-200P: 1.500	P. 113
229 (0x00E5)	Linearize type selection (Input 1)	R/W	0: Unused 1 to 20: Used Relevant pressure sensors: CZ-100P or CZ-200P	0	P. 114
230 (0x00E6)	Shunt resistance output value (Input 1)	R/W	40.0 to 100.0 %	80.0	P. 115
231 (0x00E7)	Input 1_PV transfer function	R/W	0: Unused 1: Used	0	P. 115
232 (0x00E8)	Input 2_PV transfer function	R/W		0	P. 115
233 (0x00E9)	Input 1_MV scaling high (Input 1)	R/W	-1999.9 to +9999.9	100.0	P. 116
234 (0x00EA)	Input 1_MV scaling low (Input 1)	R/W		0.0	P. 117
235 (0x00EB)	Decimal point position of MV scaling (Input 1)	R/W	0: No decimal place 1: One decimal place 2: Two decimal places 3: Three decimal places 4: Four decimal places	1	P. 117

Continued on the next page.

Continued from the previous page.

Attribute ID	Name	Attribute	Data range	Factory set value	Reference page
236 (0x00EC)	Input 1_AT action	R/W	0: AT function (PID) 1: AT function (PI) 2: No AT function	2	P. 117
237 (0x00ED)	Input 2_AT action	R/W		2	P. 117
238 (0x00EE)	Input 1_manipulated output value when transferred to Auto from Manual	RO	-5.0 to +105.0 %	—	P. 118
239 (0x00EF)	Input 2_manipulated output value when transferred to Auto from Manual	RO		—	P. 118
240 (0x00F0)	Interlock function	R/W	Bit data Bit 0: OUT1 Bit 1: OUT2 Bit 2: OUT3 Bit 3: OUT4 Bit 4: OUT5 Bit 5 to Bit 31: Unused Data 0: No Interlock function 1: Interlock function [Decimal number: 0 to 31]	0	P. 119
241 (0x00F1)	Input 1_MV transfer function	R/W	0: Unused 1: Used	0	P. 121
242 (0x00F2)	Input 2_MV transfer function	R/W		0	P. 121
243 (0x00F3) ⋮ 255 (0x00FF)	Unused	—	—	—	—

6. COMMUNICATION DATA DESCRIPTION

■ Reference to communication data contents

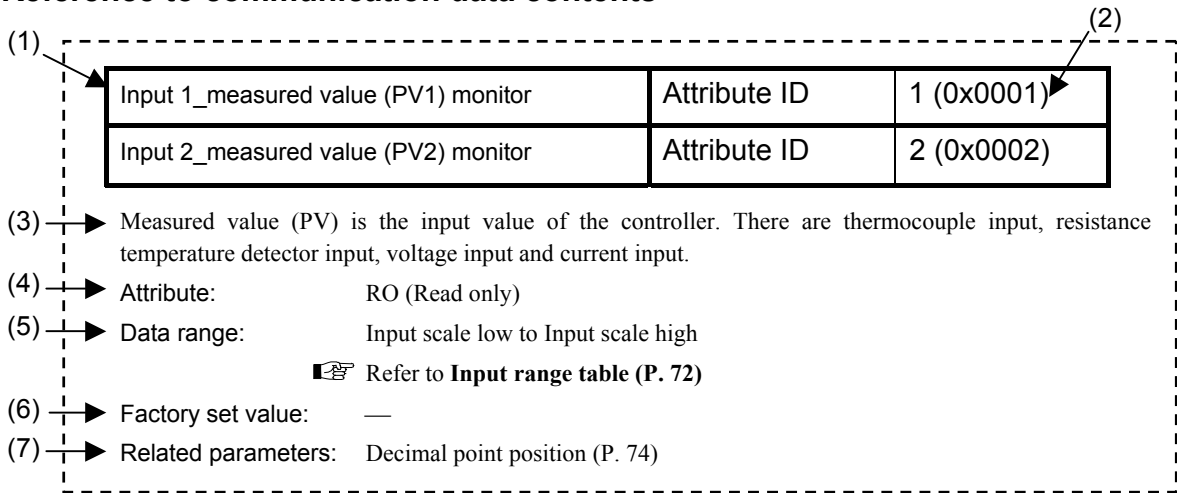

- (1) Name: Communication data name is written.
- (2) Attribute ID: The attribute ID number of communication item is written. These attribute ID numbers are written using both of decimal and hexadecimal (in parenthesis) numbers.
- (3) Description: A short description of the communication data item is written.
- (4) Attribute: A method of how communication data items are read or written when viewed from the host computer is described.
- RO: Only reading data is possible.
- Host computer ← Data direction The controller
- R/W: Reading and writing data is possible.
- Host computer ← Data direction The controller
- (5) Data range: The reading range or the writing range of communication data is written.
- (6) Factory set value: The factory set value of communication data is written.
- (7) Related parameters: A name and a page of related parameters are written.

There is item including the functional description.

Input 1_measured value (PV1) monitor	Attribute ID	1 (0x0001)
Input 2_measured value (PV2) monitor	Attribute ID	2 (0x0002)

Measured value (PV) is an input value of the controller. There are Thermocouple input (TC), Resistance temperature detector input (RTD), Voltage input (V) and Current input (I).

Attribute: RO (Read only)

Data range: Input scale low to Input scale high

 Refer to **Input range table (P. 72)**

Factory set value: —

Related parameters: Decimal point position (P. 74)

Input 1_set value (SV1) monitor	Attribute ID	6 (0x0006)
Input 2_set value (SV2) monitor	Attribute ID	7 (0x0007)

This value is a monitor of the Set value (SV) that is a desired value for control.

Attribute: RO (Read only)

Data range: Setting limiter low to Setting limiter high

 Refer to **Input range table (P. 72)**

Factory set value: —

Related parameters: Decimal point position (P. 74)

Remote input value monitor	Attribute ID	8 (0x0008)
----------------------------	--------------	------------

This value is an input value that is used for remote input function.

Attribute: RO (Read only)

Data range: Input 1_setting limiter low to Input 1_setting limiter high

 Refer to **Input range table (P. 72)**

Factory set value: —

Input 1_burnout state	Attribute ID	10 (0x000A)
Input 2_burnout state	Attribute ID	11 (0x000B)

This value expresses a state in input break.

Attribute: RO (Read only)

Data range: Uses Bit 0 only.

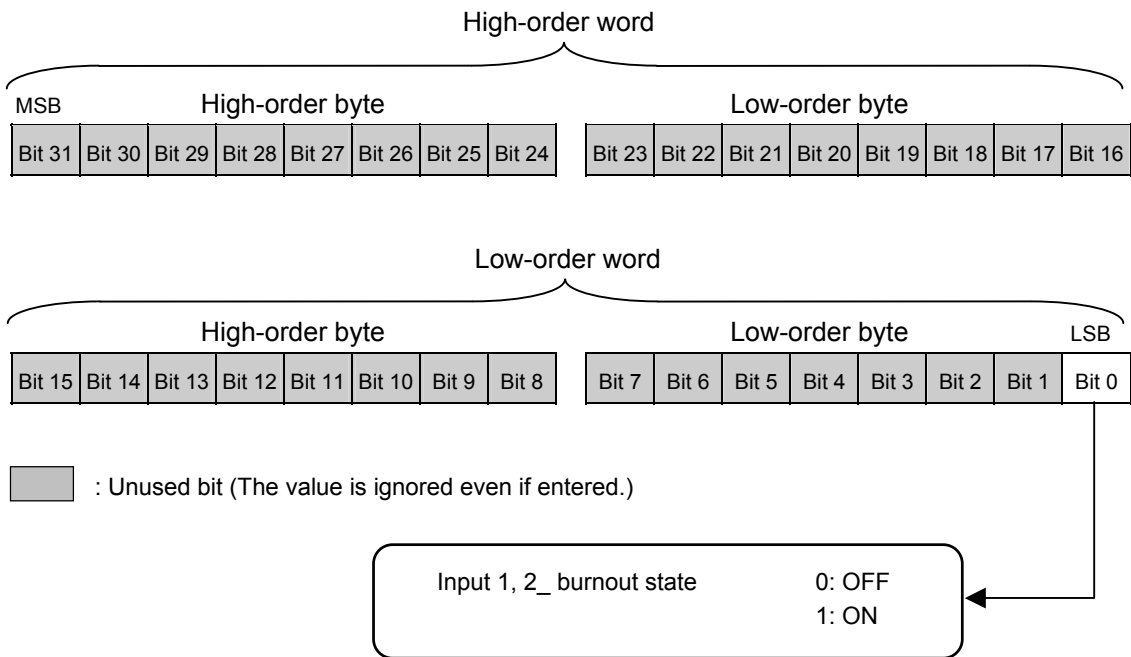

Factory set value: —

Related parameters: Burnout direction (P. 79)

Event 1 state	Attribute ID	13 (0x000D)
Event 2 state	Attribute ID	14 (0x000E)
Event 3 state	Attribute ID	15 (0x000F)
Event 4 state	Attribute ID	16 (0x0010)

This value expresses a state of the event ON/OFF.

Attribute: RO (Read only)

Data range: Uses Bit 0 only.

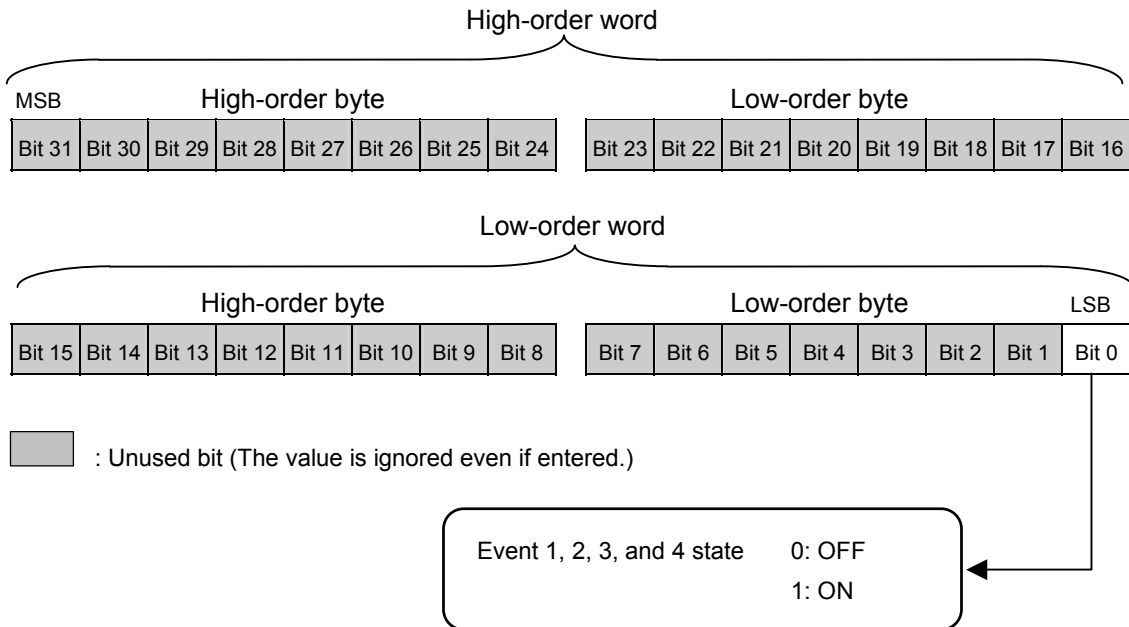

Factory set value: —

Related parameters: Event set value (P. 49), Output logic selection (P. 84), Event type selection (P. 89), Event hold action (P. 91), Event differential gap (P. 93), Event action at input error (P. 94), Event assignment (P. 95)

Input 1_manipulated output value (MV1) monitor	Attribute ID	19 (0x0013)
Input 2_manipulated output value (MV2) monitor	Attribute ID	20 (0x0014)

This value is an output value of the controller.

Attribute: RO (Read only)

Data range: -5.0 to +105.0 %

Factory set value: —

Related parameters: Manual output value (P. 62), Output logic selection (P. 84), Output change rate limiter (up/down) (P. 103), Output limiter (high/low) (P. 105)

Error code	Attribute ID	21 (0x0015)
------------	--------------	-------------

Each error state of the controller is expressed in bit data items.

Attribute: RO (Read only)

Data range: 0 to 4095 (bit data)

Bit 0 to Bit 5, Bit 7 and Bit 11 are used.

(Bit 6, Bit 8 to Bit 10, Bit 12 to Bit 31: Unused)

Each error state is assigned as a bit image in binary numbers.

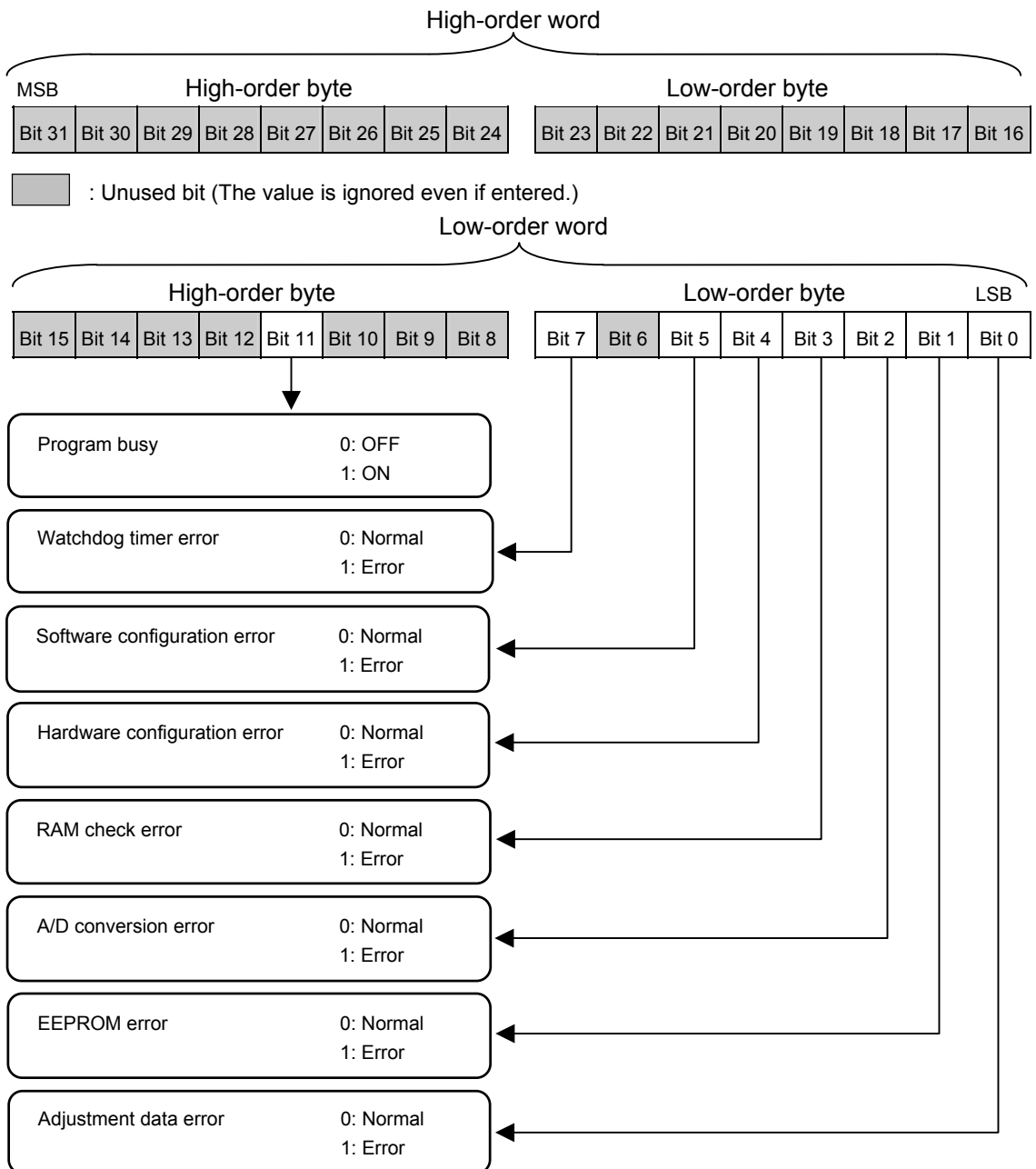

Factory set value: —

Event input (DI) state	Attribute ID	22 (0x0016)
------------------------	--------------	-------------

Each event input state of the controller is expressed in bit data items.

Attribute: RO (Read only)
 Data range: 0 to 31 (Bit data)
 Bit 0 to Bit 4 are used. (Bit 5 to Bit 31: Unused)
 Error event input (DI) state is assigned as a bit image in binary numbers.

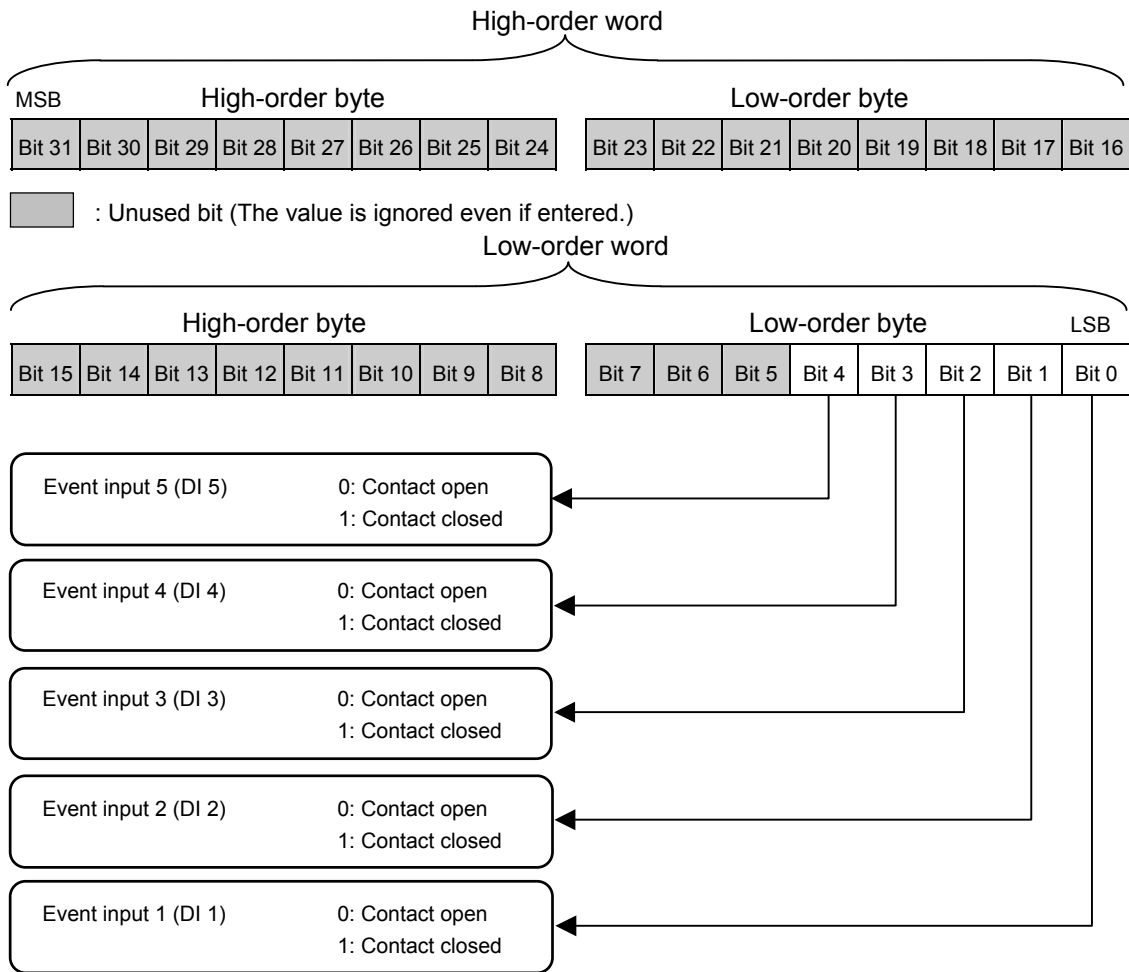

Factory set value: —
 Related parameters: Event input logic selection (P. 81)

Operation mode state	Attribute ID	23 (0x0017)
----------------------	--------------	-------------

Each operation mode state of the controller is expressed in bit data items.

Attribute: RO (Read only)

Data range: 0 to 31 (Bit data)

Bit 0 to Bit 4 are used. (Bit 5 to Bit 31: Unused)

Each operation mode state is assigned as a bit image in binary numbers.

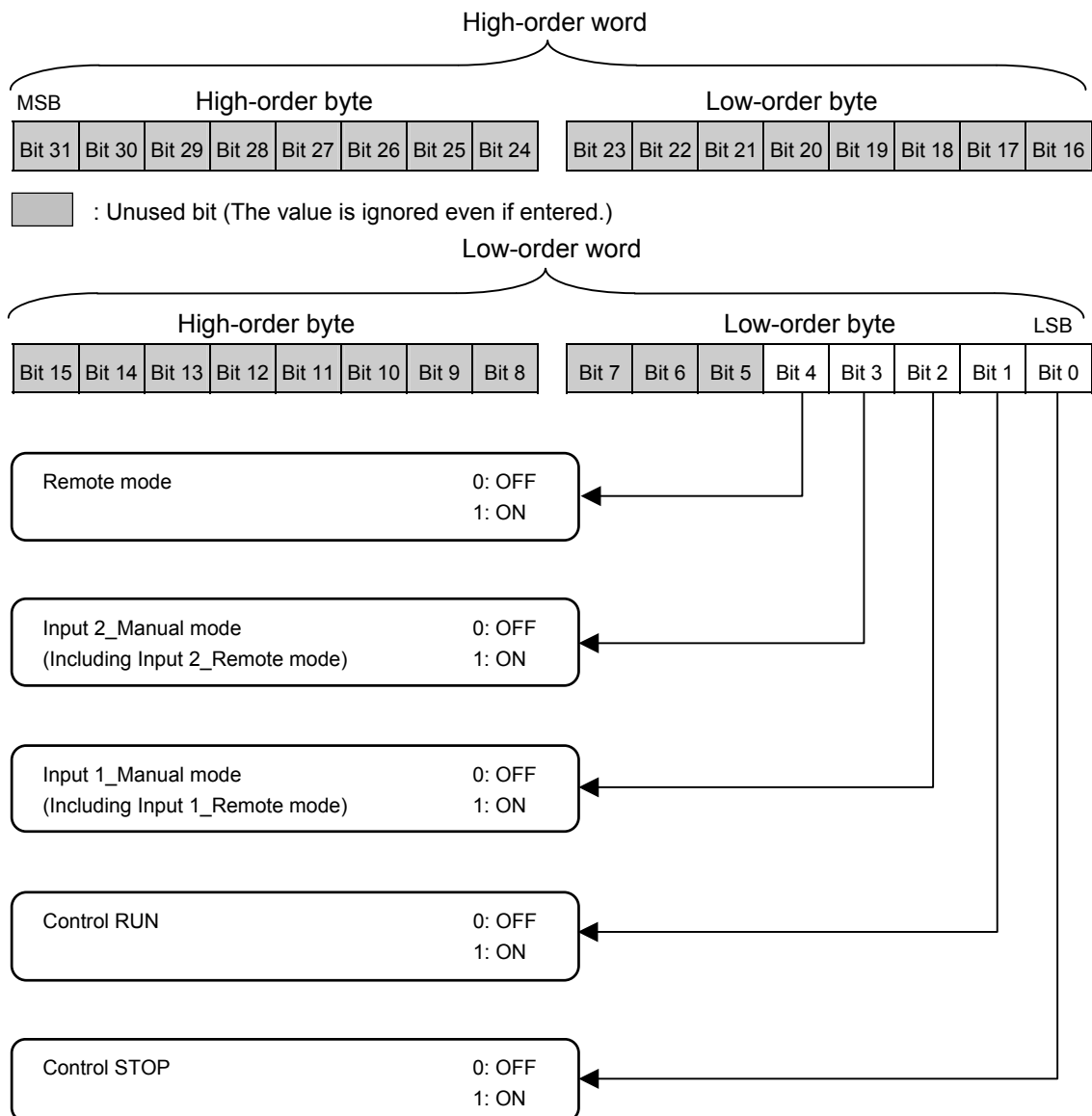

Factory set value: —

Related parameters: Auto/Manual transfer (P. 48), Remote/Local transfer (P. 48),
RUN/STOP transfer (P. 48), Input 2_use selection (P. 96)

Memory area soak time monitor	Attribute ID	24 (0x0018)
-------------------------------	--------------	-------------

Monitors the time elapsed for memory area operation (soak time) when Ramp/Soak control by using multi-memory area is performed.

Attribute: RO (Read only)

Data range: 0 minute 00.00 second to 9 minutes 59.99 seconds or
0 hour 00 minute 00 second to 9 hours 59 minutes 59 seconds

 Memory area soak time monitor is expressed in second unit for DeviceNet communication.

0 minute 00.00 second to 9 minutes 59.99 seconds:
0 to 59999 seconds

0 hour 00 minute 00 second to 9 hours 59 minutes 59 seconds:
0 to 35999 seconds

Factory set value: —

Related parameters: Area soak time (P. 57), Soak time unit selection (P. 109)

 As the area soak time for the memory area linked last becomes invalidated, no area soak time is monitored.

Input 1_PID/AT transfer	Attribute ID	25 (0x0019)
Input 2_PID/AT transfer	Attribute ID	26 (0x001A)

This item transfers PID control and Autotuning (AT).

Attribute: R/W (Read and Write)

 **Input 1_PID/AT transfer becomes RO (Read only) when “2: No AT function” is selected in “Input 1_AT action.”**

 **Input 2_PID/AT transfer becomes RO (Read only) when “2: No AT function” is selected in “Input 2_AT action.”**

 **Input 2_PID/AT transfer becomes RO (Read only) for 1-input controller.**

Data range: 0: PID control
1: Autotuning (AT)

Factory set value: Input 1_PID/AT transfer: 0
Input 2_PID/AT transfer: 0

 No PID/AT transfer is validated prior to factory shipment. The transfer becomes validated only when “1: AT function (PI)” or “0: AT function (PID)” is selected in AT action selection.

Related parameters: AT bias (P. 106), AT cycle (P. 107), AT differential gap time (P. 108)
AT action (P. 117)

Continued on the next page.

Continued from the previous page.

Autotuning (AT): Autotuning (AT) function automatically measures, calculates and sets the optimum PID (PI) constants. The followings are the conditions necessary to carry out autotuning and the conditions which will cause the autotuning to stop.

Requirements for AT start:

Start the Autotuning when all following conditions are satisfied:

- Operation mode conditions are as follows:
 - Auto/Manual transfer → Auto mode
 - Remote/Local transfer → Local mode
 - PID/AT transfer → PID control
 - RUN/STOP transfer → Control RUN
- The Measured value (PV) is without input error range [Input error determination point (high) > Measured value (PV) > Input error determination point (low)].
- The output limiter high is 0.1 % or higher and the output limiter low is 99.9 % or less.



When the Autotuning is finished, the controller will automatically returns to PID (PI) control.

Requirements for AT cancellation:

- When the temperature set value (SV) is changed.
- When the output limiter high or the output limiter low is changed.
- When the PV bias, the PV digital filter, or the PV ratio is changed.
- When the Auto/Manual mode is changed to the Manual mode.
- When the Remote/Local mode is changed to the Remote mode.
- When the Measured value (PV) goes to input error range [Measured value (PV) \geq Input error determination point (high) or Input error determination point (low) \geq Measured value (PV)].
- When the power failure occurs.
- When the instrument is in the FAIL state.
- When the PID/AT transfer is changed to the PID control.
- When the RUN/STOP mode is changed to the control STOP.



If the AT is canceled, the controller immediately changes to PID (PI) control. The PID (PI) values will be the same as before AT was activated.

Input 1_Auto/Manual transfer	Attribute ID	27 (0x001B)
Input 2_Auto/Manual transfer	Attribute ID	28 (0x001C)

This item transfers the Automatic (AUTO) control and the Manual (MAN) control.

Attribute: R/W (Read and Write)



The Input 2_Auto/Manual transfer becomes RO (Read only) for the 1-input controller.

Data range: 0: Auto mode
1: Manual mode

Factory set value: Input 1_Auto/Manual transfer: 1
Input 2_Auto/Manual transfer: 1

Related parameters: Operation mode state (P. 45)

Remote/Local transfer	Attribute ID	29 (0x001D)
-----------------------	--------------	-------------

This item selects to use the set value of local or remote input.

Attribute: R/W (Read and Write)



This item becomes RO (Read only) besides the remote input specification.

Data range: 0: Local mode
1: Remote mode

Factory set value: 0

Related parameters: Operation mode state (P. 45)

RUN/STOP transfer	Attribute ID	30 (0x001E)
-------------------	--------------	-------------

This item transfers Control RUN and Control STOP.

Attribute: R/W (Read and Write)

Data range: 0: Control RUN
1: Control STOP

Factory set value: 0

Related parameters: Operation mode state (P. 45)



If the controller is transferred to STOP mode from RUN mode, the controller status is the same as the Power-off. However for the specification with current output (other than 0 to 20 mA) or voltage output, an output of -5 % is fed when at STOP.



Operation when transferred RUN from STOP is in accordance with the Hot/Cold start selection* setting.

* Cold start (factory shipment): The controller will automatically go to Manual mode and output from the low output limit value (factory set value: -5.0 %).

Memory area selection	Attribute ID	31 (0x001F)
-----------------------	--------------	-------------

This item selects the memory area to use for control.

Attribute: R/W (Read and Write)
 Data range: 1 to 16
 Factory set value: 1

Event 1 set value	Attribute ID	32 (0x0020)
Event 2 set value	Attribute ID	33 (0x0021)
Event 3 set value	Attribute ID	34 (0x0022)
Event 4 set value	Attribute ID	37 (0x0025)

Event 1 through Event 4 are set values of the event action.

Attribute: R/W (Read and Write)



The Event 3 set value becomes RO (Read only) when it was selected “9: Control loop break alarm (LBA)” from the Event 3 type selection.



The Event 4 set value becomes RO (Read only) when it was selected “9: Control loop break alarm (LBA)” from the Event 4 type selection.

Data range: Deviation: –Input span to +Input span
 Process: Input scale low to Input scale high
 SV: Input scale low to Input scale high

Factory set value: 50.0

Related parameters: Event state (P. 42), Event type selection (P. 89), Event hold action (P. 91),
 Event differential gap (P. 93), Event action at input error (P. 94),
 Event assignment (P. 95)

Control loop break alarm 1 (LBA1) time	Attribute ID	35 (0x0023)
Control loop break alarm 2 (LBA2) time	Attribute ID	38 (0x0026)

The LBA time sets the time required for the LBA function to determine there is a loop failure. When the LBA is output (under alarm status), the LBA function still monitors the Measured value (PV) variation at an interval of the LBA time.

Attribute: R/W (Read and Write)



The control loop break alarm 1 (LBA1) time becomes RO (Read only) when it was selected “1 to 8” from the Event 3 type selection.



The control loop break alarm 2 (LBA2) time becomes RO (Read only) when it was selected “1 to 8” from the Event 4 type selection.

Data range: 0 to 7200 seconds (0: Unused)

Factory set value: 480

Related parameters: Event state (P. 42), Event assignment (P. 95), LBA deadband (P. 50)

LBA function: Refer to the next page.

LBA1 deadband	Attribute ID	36 (0x0024)
LBA2 deadband	Attribute ID	39 (0x0027)

The LBA deadband gives a neutral zone to prevent the Control loop break alarm (LBA) from malfunctioning caused by disturbance.

Attribute: R/W (Read and Write)



The LBA1 deadband becomes RO (Read only) when it was selected “1 to 8” from the Event 3 type selection.



The LBA2 deadband becomes RO (Read only) when it was selected “1 to 8” from the Event 4 type selection.

Data range: 0 to Input span
(Varies with the setting of the Decimal point position)

Factory set value: 0.0

Related parameters: Event state (P. 42), Event assignment (P. 95),
Control loop break alarm (LBA) time (P. 50)

LBA deadband function:
Refer to the next page.

■ LBA function

Control loop break alarm (LBA):

The control loop break alarm (LBA) function is used to detect a load (heater) break or a failure in the external actuator (power controller, magnet relay, etc.), or a failure in the control loop caused by an input (sensor) break. The LBA function is activated when control output reaches 0 % (low limit with output limit function) or 100 % (high limit with output limit function). LBA monitors variation of the Measured value (PV) for the length of LBA time. When the LBA time has elapsed and the PV is still within the alarm determination range, the LBA will be ON.

[Alarm action]

LBA determination range: Temperature input: 2 °C [2 °F] (fixed)
 Pressure sensor input and Voltage/Current input:
 0.2 % of input span (fixed)

• When the output reaches 0 % (low limit with output limit function)

For direct action: When the LBA time has passed and the PV has not risen beyond the alarm determination range, the alarm will be turned on.

For reverse action: When the LBA time has passed and the PV has not fallen below the alarm determination range, the alarm will be turned on.

• When the output exceeds 100 % (high limit with output limit function)

For direct action: When the LBA time has passed and the PV has not fallen below the alarm determination range, the alarm will be turned on.

For reverse action: When the LBA time has passed and the PV has not risen beyond the alarm determination range, the alarm will be turned on.



If the Autotuning function is used, the LBA time is automatically set twice as large as the integral time. The LBA setting time will not be changed even if the integral time is changed.

LBA deadband function:

The LBA may malfunction due to external disturbance. To prevent malfunctioning due to external disturbance, LBA deadband (LBD) sets a neutral zone in which LBA is not activated. When the Measured value (PV) is within the LBD area, LBA will not be activated. If the LBD setting is not correct, the LBA will not work correctly.

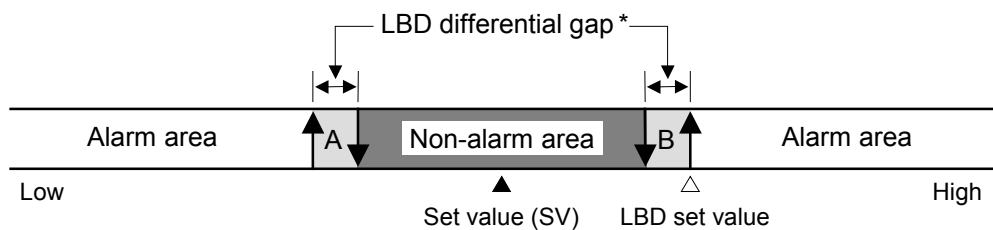

- A: During temperature rise: Alarm area
 During temperature fall: Non-alarm area
 B: During temperature rise: Non-alarm area
 During temperature fall: Alarm area

* LBD differential gap: TC/RTD input: 0.8 °C [°F] (Fixed)
 Pressure sensor input and Voltage/Current input:
 0.8 % of input span (Fixed)

Continued on the next page.

Continued from the previous page.



If the LBA function detects an error occurring in the control loop, but cannot specify the location, a check of the control loop in order. The LBA function does not detect a location which causes alarm status. If LBA alarm is ON, check each device or wiring of the control loop.



LBA function is not operative when:

- AT function is activated.
- The controller is in STOP mode.
- LBA function is set to “0.”
- LBA function is not assigned to Event 3 or Event 4.



If the LBA time is too short or does not match the controlled object requirements, LBA may turn ON or OFF at inappropriate time or remain OFF. Change the LBA time based on the malfunction.



While the LBA is ON (under alarm status), the following conditions cancel the alarm status and LBA will be OFF:

- The Measured value (PV) rises beyond (or falls below) the LBA determination range within the LBA time.
- The Measured value (PV) enters within the LBA deadband.

Input 1_set value (SV1)	Attribute ID	40 (0x0028)
Input 2_set value (SV2)	Attribute ID	46 (0x002E)

The Set value (SV) is a desired value of the control.

Attribute: R/W (Read and Write)



The Input 2_set value (SV2) becomes RO (Read only) for the 1-input controller.

Data range: Setting limiter low to Setting limiter high



Refer to **Input range table (P. 72)**

Factory set value: Input 1_set value (SV1): 0
Input 2_set value (SV2): 0

Related parameters: Setting limiter high/low (P. 110)

Input 1_proportional band	Attribute ID	41 (0x0029)
Input 2_proportional band	Attribute ID	47 (0x002F)

This value expresses a proportional band of the PI and PID control.

Attribute: R/W (Read and Write)



The Input 2_proportional band becomes RO (Read only) for the 1-input controller.

Data range: Pressure sensor input: 0.0 to 1000.0 % of input span
 TC/RTD inputs: 0 (0.0, 0.00) to Input span (Unit: °C [°F])
 (Varies with the setting of the Decimal point position)
 Voltage (V)/Current (I) inputs: 0.0 to 1000.0 % of input span
 0 (0.0, 0.00): ON/OFF action

Factory set value: Input 1_proportional band: 100.0
 Input 2_proportional band: 30.0

Related parameters: ON/OFF action differential gap (upper) (P. 99),
 ON/OFF action differential gap (lower) (P. 100)

Input 1_integral time	Attribute ID	42 (0x002A)
Input 2_integral time	Attribute ID	48 (0x0030)

Integral action is to eliminate offset between SV and PV by proportional action. The degree of Integral action is set by time in seconds.

Attribute: R/W (Read and Write)



The Input 2_integral time becomes RO (Read only) for the 1-input controller.

Data range: 0 to 3600 seconds, 0.0 to 3600.0 seconds, or 0.00 to 360.00 seconds
 (0, 0.0 or 0.00: PD action)
 Varies with the setting of the Integral/Derivative time decimal point position selection.

Factory set value: Input 1_integral time: 5.00
 Input 2_integral time: 240.00

Related parameters: Integral/Derivative time decimal point position selection (P. 98)

Input 1_derivative time	Attribute ID	43 (0x002B)
Input 2_derivative time	Attribute ID	49 (0x0031)

Derivative action is to prevent rippling and make control stable by monitoring output change. The degree of Derivative action is set by time in seconds.

Attribute: R/W (Read and Write)

 **The Input 2_derivative time becomes RO (Read only) for the 1-input controller.**

Data range: 0 to 3600 seconds, 0.0 to 3600.0 seconds, or 0.00 to 360.00 seconds
 (0, 0.0 or 0.00: PI action)
 Varies with the setting of the Integral/Derivative time decimal point position selection.

Factory set value: Input 1_derivative time: 0.00 (PI action)
 Input 2_derivative time: 60.00

Related parameters: Integral/Derivative time decimal point position selection (P. 98)

Input 1_control response parameter	Attribute ID	44 (0x002C)
Input 2_control response parameter	Attribute ID	50 (0x0032)

The control response for the Set value (SV) change can be selected among Slow, Medium, and Fast.

Attribute: R/W (Read and Write)

 **The Input 2_control response parameter becomes RO (Read only) for the 1-input controller.**

Data range: 0: Slow
 1: Medium
 2: Fast

Factory set value: Input 1_control response parameter: 0
 Input 2_control response parameter: 0

Control response: The control response for the Set value (SV) change can be selected among Slow, Medium, and Fast. If a fast response is required, Fast is chosen. Fast may cause overshoot. If overshoot is critical, Slow is chosen.

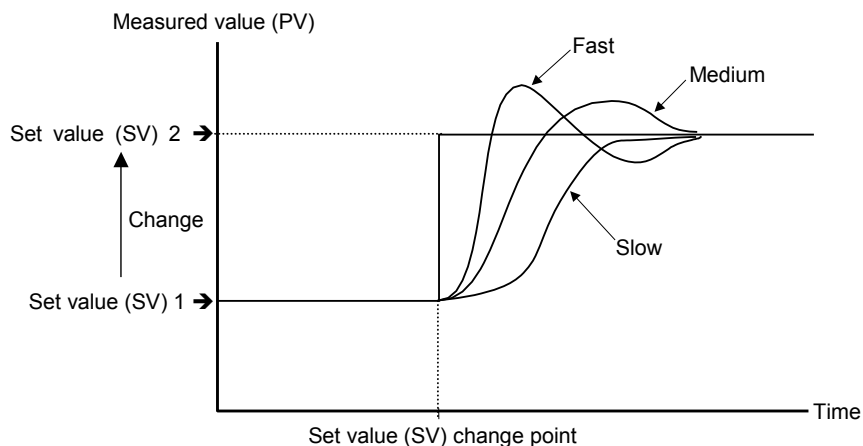

Input 1_setting change rate limiter (up)	Attribute ID	52 (0x0034)
Input 2_setting change rate limiter (up)	Attribute ID	54 (0x0036)

This function is to allow the Set value (SV) to be automatically changed at specific rates when a new Set value (SV).

Attribute: R/W (Read and Write)



The Input 2_setting change rate limiter up becomes RO (Read only) for the 1-input controller.

Data range: 0 to Input span/unit time * * Unit time: 60 seconds (factory set value)
 0: OFF (Unused)
 (Varies with the setting of the Decimal point position)

Factory set value: Input 1_setting change rate limiter (up): 0.0
 Input 2_setting change rate limiter (up): 0.0

Related parameters: Setting change rate limiter unit time (P. 109)

Input 1_setting change rate limiter (down)	Attribute ID	53 (0x0035)
Input 2_setting change rate limiter (down)	Attribute ID	55 (0x0037)

This function is to allow the Set value (SV) to be automatically changed at specific rates when a new Set value (SV).

Attribute: R/W (Read and Write)



The Input 2_setting change rate limiter (down) becomes RO (Read only) for the 1-input controller.

Data range: 0 to Input span/unit time * * Unit time: 60 seconds (factory set value)
 0: OFF (Unused)
 (Varies with the setting of the Decimal point position)

Factory set value: Input 1_setting change rate limiter (down): 0.0
 Input 2_setting change rate limiter (down): 0.0

Related parameters: Setting change rate limiter unit time (P. 109)

Continued on the next page.

Continued from the previous page.

■ Setting change rate limiter

Application examples of Setting change rate limiter:

- Increasing the SV to a higher value

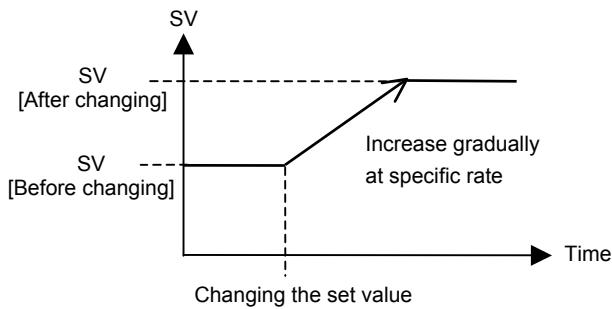

- Decreasing the SV to a lower value

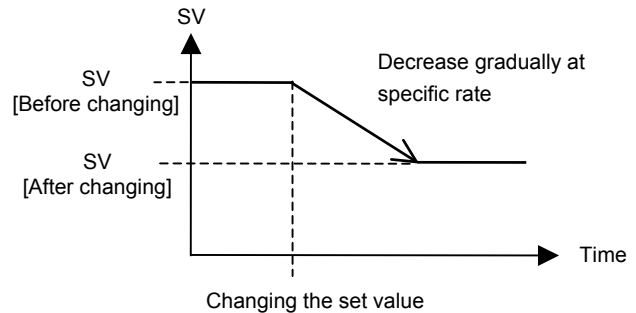

When the Setting change rate limiter is used, the SV will also ramp up or ramp down by the function at power-on and operation mode change from STOP to RUN.



If the Autotuning (AT) function is activated while the SV is ramping up or ramping down by the Setting change rate limiter, AT will start after the SV finishes ramp-up or ramp-down by the limiter, and the controller is in PID control mode until AT starts.



When the value of Setting change rate limiter is changed during normal operation, the ramp-up or ramp-down rate will be changed unless the SV already has finished ramp-up or ramp-down by the function.



If the rate of Setting change limiter is set to any value other than “0: OFF (Unused),” the event re-hold action to be taken by a Set value (SV) change becomes invalidated.

Area soak time	Attribute ID	56 (0x0038)
----------------	--------------	-------------

Area soak time is used for Ramp/Soak control function in conjunction with Link area number and Setting change rate limiter (up/down). (Refer to P. 58)

Attribute: R/W (Read and Write)

Data range: 0 minute 00.00 second to 9 minutes 59.99 seconds or
0 hour 00 minute 00 second to 9 hours 59 minutes 59 seconds

Factory set value: 0.00.00 (0 minute 00.00 second to 9 minute 59.99 seconds)

Related parameters: Soak time unit selection (P. 109)



The Area soak time can be changed during normal operation with Ramp/Soak control function, but Read the following example carefully how the time change affects Ramp/Soak control time. For example, the Memory area which has 5-minute soak time is executed. When 3 minutes passed, the Area soak time is changed from 5 minutes to 10 minutes. The remaining time of the currently executed Memory area is calculated as follows.

(The new soak time 10 minutes) – (lapsed time 3 minutes) = (remaining time 7 minutes)

The old soak time does not have any effect on remaining time.

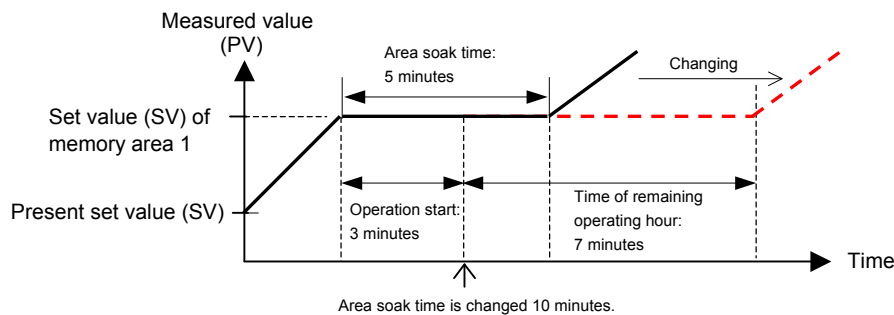

For the instrument with the 2-input specification, its area soaking starts based on the arrival at the memory area set value of Input 1 or that of Input 2, whichever later.

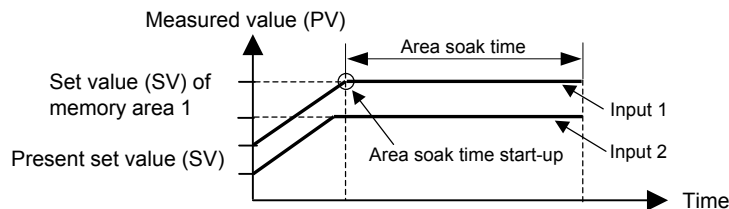

Link area number	Attribute ID	57 (0x0039)
------------------	--------------	-------------

Link area number is used for Ramp/Soak control function in conjunction with Area soak time and Setting change rate lim invalidated iter (up/down).

Attribute: R/W (Read and Write)

Data range: 0 to 16
0: OFF (No link)

Factory set value: 0

Ramp/Soak control function:

Ramp/Soak control is possible by using Area soak time, Link area number and Setting change rate limiter (up/down) in Parameter setting mode.

[Usage example]

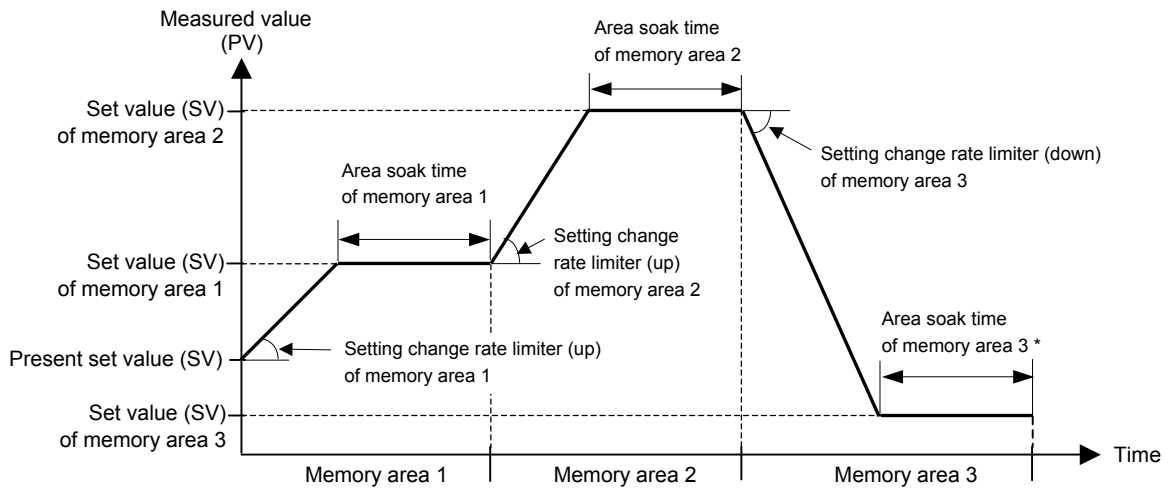

* The Area soak time for the memory area linked last becomes invalidated to continue the state of the set value (SV) reached.

Input 1_PV bias	Attribute ID	60 (0x003C)
Input 2_PV bias	Attribute ID	66 (0x0042)

PV bias adds bias to the Measured value (PV). The PV bias is used to compensate the individual variations of the sensors or correct the difference between the Measured value (PV) of other instruments.

Attribute: R/W (Read and Write)



The Input 2_PV bias becomes RO (Read only) for the 1-input controller.

Data range: -Input span to +Input span

Factory set value: Input 1_PV bias: 0

Input 2_PV bias: 0

Related parameter: Auto-zero (P. 68)



The Input 1_PV bias value is also reflected to the result of Auto-zero adjustment. Manual zero point adjustment can be performed by changing this PV bias value*.

* Relevant pressure sensors: CZ-100P or CZ-200P

Input 1_PV digital filter	Attribute ID	61 (0x003D)
Input 2_PV digital filter	Attribute ID	67 (0x0043)

This item is the time of the first-order lag filter eliminate noise against the measured input.

Attribute: R/W (Read and Write)



The Input 2_PV digital filter becomes RO (Read only) for the 1-input controller.

Data range: 0.00 to 10.00 seconds

0.00: OFF (Unused)

Factory set value: Input 1_PV digital filter: 0.00

Input 2_PV digital filter: 0.00

Input 1_PV ratio	Attribute ID	62 (0x003E)
Input 2_PV ratio	Attribute ID	68 (0x0044)

PV ratio is a multiplier to be applied to the Measured value (PV). The PV bias is used to compensate the individual variations of the sensors or correct the difference between the Measured value (PV) of other instruments.

Attribute: R/W (Read and Write)



The Input 2_PV ratio becomes RO (Read only) for the 1-input controller.

Data range: 0.500 to 1.500

Factory set value: Input 1_PV ratio: 1.000
Input 2_PV ratio: 1.000

Related parameter: Auto calibration (P. 68)



When using our CZ-100P or CZ-200P:

- Explosionproof specification type:

Set the desired correction factor of our safety barrier RZB-001 to the Input 1_PV ratio. Thus, an indicated error caused by the use of the safety barrier is corrected. The correction factor is described in the nameplate attached to the safety barrier (RZB-001).

- Non-explosionproof specification type:

As the Input 1_PV ratio, use a factory set value of “1.000” with this value left intact.



When using the strain gauge type sensors other than RKC product:

The result obtained by Auto calibration is reflected to the Input 1_PV ratio. Manual full scale point adjustment can be performed by changing this PV ratio.

Input 1_PV low input cut-off	Attribute ID	63 (0x003F)
Input 2_PV low input cut-off	Attribute ID	69 (0x0045)

PV low input cut-off is used with Square root extraction function. The measured value less than the PV low input cut-off is ignored to prevent control disturbance caused by input variation at low measured value range.

Attribute: R/W (Read and Write)



This item becomes RO (Read only) during control RUN.

Data range: 0.00 to 25.00 % of input span

Factory set value: Input 1_PV low input cut-off: 0.00
Input 2_PV low input cut-off: 0.00

PV low input cut-off function:

When input signal square root extraction is used for flow control, etc., the square root extraction result varies widely at the low measured value range. The measured value less than the PV low input cut-off is ignored to calculate control output in order to prevent control disturbance caused by input variation at low measured value range.

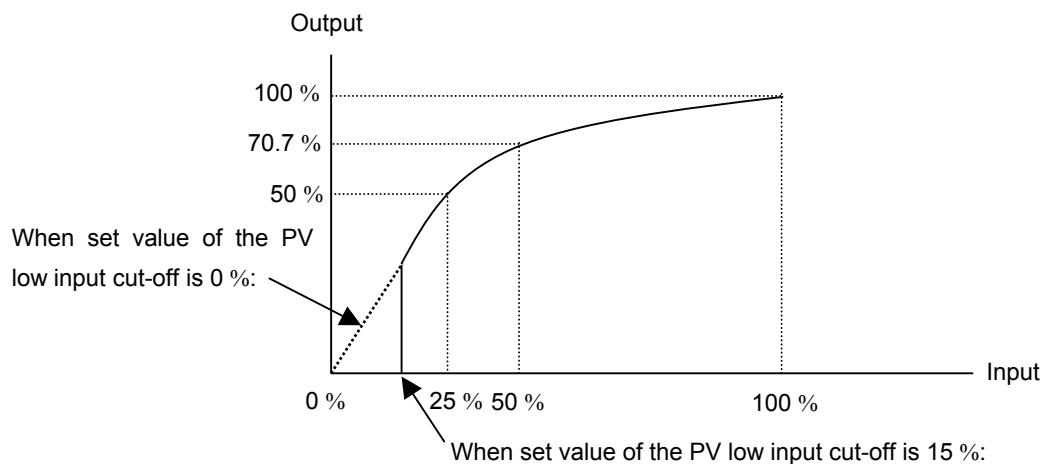

Input 1_proportional cycle time	Attribute ID	64 (0x0040)
Input 2_ proportional cycle time	Attribute ID	70 (0x0046)

Proportional cycle time is to set control cycle time for time based control output such as voltage pulse for SSR, triac and relay output.

Attribute: R/W (Read and Write)

 **This item becomes RO (Read only) for the Voltage/Current output specification.**

Data range: 0.1 to 100.0 seconds

Factory set value: Input 1_proportional cycle time:
 Relay contact output: 20.0 seconds
 Voltage pulse output and triac output: 2.0 seconds
 Input 2_proportional cycle time:
 Relay contact output: 20.0 seconds
 Voltage pulse output and triac output: 2.0 seconds

 The proportional cycle time becomes invalidated when the Voltage/Current output is selected as control output type.

Input 1_manual output value	Attribute ID	65 (0x0041)
Input 2_manual output value	Attribute ID	71 (0x0047)

This item is the output value in the manual (MAN) control.

Attribute: R/W (Read and Write)

 **This item becomes RO (Read only) for the automatic (AUTO) control.**

Data range: Input 1_manual output value: MV scaling low to MV scaling high
 Input 2_manual output value: Output limiter low to Output limiter high

Factory set value: 0.0

Related parameters: Output limiter high/low (P. 105), MV scaling high (P. 116),
 MV scaling low (P. 117)

Set lock level	Attribute ID	72 (0x0048)
----------------	--------------	-------------

The set lock level restricts parameter setting changes by key operation (Set data lock function). This function prevents the operator from making errors during operation.

Attribute: R/W (Read and Write)

Data range: 0 to 7 (Bit data)

Bit 0 to Bit 2 are used. (Bit 3 to Bit 31: Unused)

The set lock level is assigned as a bit image in binary numbers.

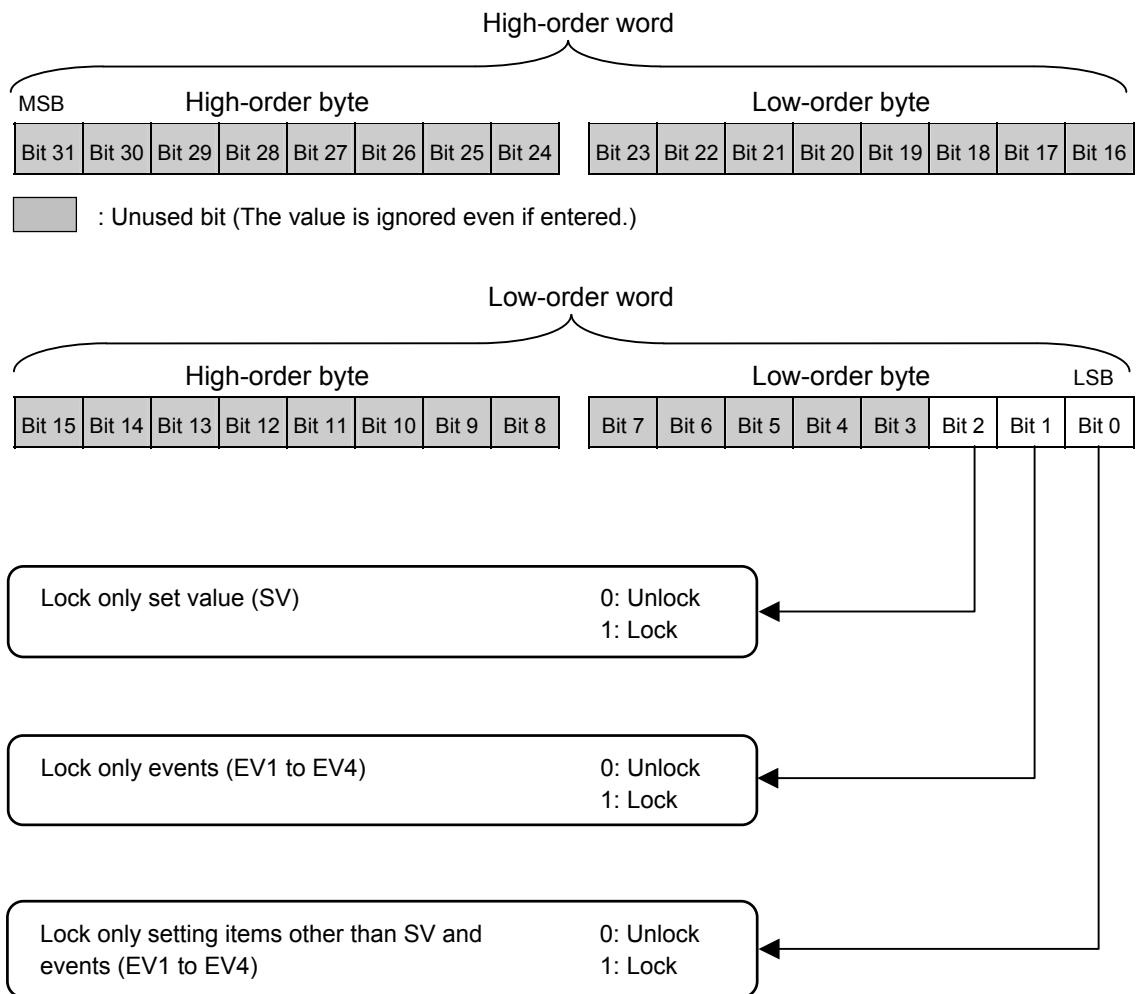

Factory set value: 0

EEPROM storage state	Attribute ID	73 (0x0049)
----------------------	--------------	-------------

The contents of the RAM and those of the EEPROM can be checked.

Attribute: RO (Read only)

Data range:

0: The content of the EEPROM does not coincide with that of the RAM.

- As data is being written to the EEPROM when the EEPROM storage mode is selected “0: Set values are store to the EEPROM when set values are changed,” do not turn the power off. If turned off, no set values are stored.
- If the EEPROM storage mode is changed after “0: Set values are store to the EEPROM when set values are changed” is changed to “1: Not set values are store to the EEPROM when set values are changed,” 0 is set (mismatch). As the set value changed is not backup, select the backup mode if necessary.

1: The content of the EEPROM coincides with that of the RAM.
The contents of the RAM match with those of the EEPROM.
(Data write to the EEPROM is completed.)

Factory set value: —

EEPROM storage mode	Attribute ID	74 (0x004A)
---------------------	--------------	-------------

It is set whether the data storage in the non-volatile memory (EEPROM) is executed or not.

Attribute: R/W (Read and Write)

Data range:

0: Set values are store to the EEPROM when set values are changed.

1: Not set values are store to the EEPROM when set values are changed.

Factory set value: 0



When the memory is used to frequently change the set value via communication, select “1: Not set values are store to the EEPROM when set values are changed.”



For the following case, data is stored into the EEPROM regardless of the EEPROM mode setting.

- **When the data is changed through key operation**
- **Data written into the controller by specifying the memory area number**



The non-volatile memory (EEPROM) has limitations on the number of memory rewrite times. If “1: Not set values are store to the EEPROM when set values are changed” is selected as the EEPROM storage mode, all of the set values changed are not written to the EEPROM and thus a problem of limitations on the number of memory rewrite times can be solved.

Continued on the next page.

Continued from the previous page.



When selecting any EEPROM storage mode, take notice of the following.

- If power failure occurs while “1: Not set values are store to the EEPROM when set values are changed” is selected, the set value returns to the value before the storage mode is selected.
- If “1: Not set values are store to the EEPROM when set values are changed” is changed to “0: Set values are store to the EEPROM when set values are changed,” all of the set values at that time are stored to the EEPROM. If necessary to backup the final value of each set item, select “0: Set values are store to the EEPROM when set values are changed.”
- When the power is turned on, “0: Set values are store to the EEPROM when set values are changed” is always set.

PV1 peak hold value monitor	Attribute ID	79 (0x004F)
PV2 peak hold value monitor	Attribute ID	82 (0x0052)

The maximum PV value (peak value) of Input 1 (Input 2) is held and displayed.

Attribute: RO (Read only)

Data range: Input scale low to Input scale high

Factory set value: —

Related parameters: PV1/PV2 bottom hold value monitor (P. 66), PV1/ PV2 hold reset (P. 67), Input 1_PV1 hold function (P. 113), Input 2_PV2 hold function (P. 113)

Peak hold function: The Peak hold function is used to store (hold) the maximum (peak) measured value (PV). The peak hold value is updated regardless of the STOP or RUN state if the power to this controller is turned on. Each of this value is updated when the Measured value (PV) becomes more than the value now being held. However, if the following operation is performed, the value now being held is reset and as a result the Measured value (PV) just when reset becomes the peak hold value.

- When the power is turned on or it is turned on again
- When operation mode is changed from STOP to RUN
- When hold reset



Peak hold value is not backed up.

Continued on the next page.

Continued from the previous page.

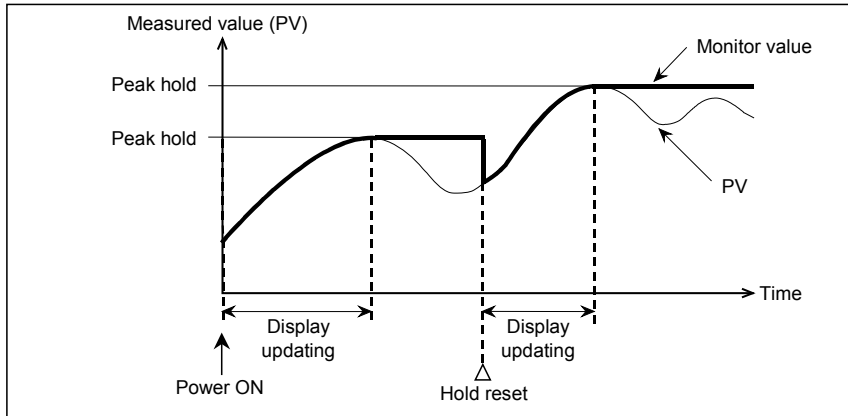

PV1 bottom hold value monitor	Attribute ID	80 (0x0050)
PV2 bottom hold value monitor	Attribute ID	83 (0x0053)

The minimum PV value (bottom value) of Input 1 (Input 2) is held and displayed.

Attribute: RO (Read only)

Data range: Input scale low to Input scale high

Factory set value: —

Related parameters: PV1/PV2 peak hold value monitor (P. 65), PV1/ PV2 hold reset (P. 67), Input 1_PV1 hold function (P. 113), Input 2_PV2 hold function (P. 113)

Bottom hold function: The Bottom hold function is used to store (hold) the minimum (bottom) measured value (PV). The bottom hold value is updated regardless of the STOP or RUN state if the power to this controller is turned on. Each of this value is updated when the Measured value (PV) becomes less than the value now being held. However, if the following operation is performed, the value now being held is reset and as a result the Measured value (PV) just when reset becomes the bottom hold value.

- When the power is turned on or it is turned on again
- When operation mode is changed from STOP to RUN
- When hold reset

 Bottom hold value is not backed up.

Continued on the next page.

Continued from the previous page.

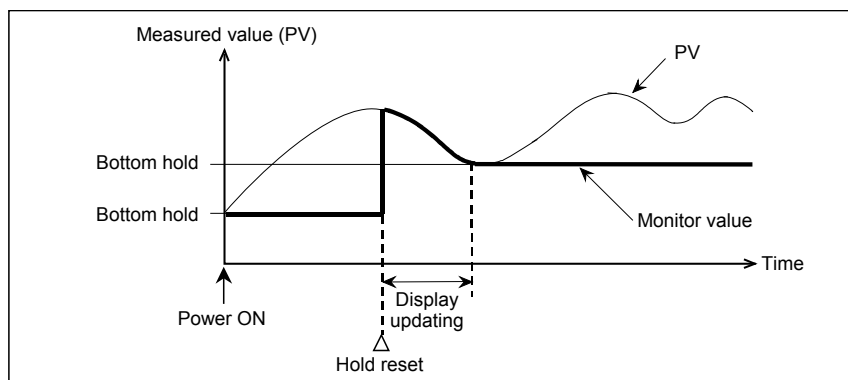

PV1 hold reset	Attribute ID	81 (0x0051)
PV2 hold reset	Attribute ID	84 (0x0054)

The maximum (peak hold) and minimum (bottom hold) PV values are reset.

Attribute: R/W (Read and Write)

Data range: 0, 1

0: Hold reset execution

If 0 is written, the hold value is reset to return to 1.

The polling of "1" is always made.

Factory set value: —

Related parameters: PV1/PV2 peak hold value monitor (P. 65),
 PV1/PV2 bottom hold value monitor (P. 66),
 Input 1_PV1 hold function (P. 113), Input 2_PV2 hold function (P. 113)

Interlock release	Attribute ID	85 (0x0055)
-------------------	--------------	-------------

Interlock status is release.

Attribute: R/W (Read and Write)

Data range: 0, 1

0: Interlock release execution

If 0 is written, the interlock is released.

Factory set value: —

Related parameters: Interlock function (P. 119)

Auto-zero	Attribute ID	86 (0x0056)
-----------	--------------	-------------

Adjust the zero point of the measured value (PV1) on the Input 1 (Pressure sensor input*) side.

* Relevant pressure sensors: CZ-100P or CZ-200P



Before conducting Auto-zero adjustment, always change RUN to STOP. In addition, before conducting Auto-zero adjustment, check that no load is applied to the pressure sensor; the equipment is at the operating temperature; and also the wiring is correctly made.

Attribute: R/W (Read and Write)

Data range: 0, 1, 3

1: Zero point adjustment execution

Writing “1” starts zero point adjustment, and then “1” returns to “0” after the adjustment is finished.

3: Adjustment error

Writing “0” returns to a normal state.



The result of Auto-zero adjustment is also reflected to the Input 1_PV bias value. Manual zero point adjustment can be performed by changing this PV bias value.

Factory set value: —

Related parameters: PV bias (P. 59)

Auto calibration	Attribute ID	87 (0x0057)
------------------	--------------	-------------

Adjust the full scale point of the measured value (PV1) on the Input 1 (Pressure sensor input*) side.

* Relevant pressure sensors: The strain gauge type sensors other than RKC product



Before conducting Auto calibration, always change RUN to STOP. In addition, before conducting Auto calibration, check that no load is applied to the pressure sensor; the equipment is at the operating temperature; and also the wiring is correctly made.

Attribute: R/W (Read and Write)

Data range: 0 to 3

1: Auto calibration execution

Writing “1” starts auto calibration, and it changes to “2” during the adjustment and returns to “0” after the adjustment is finished.

3: Adjustment error

Writing “0” returns to a normal state.



The result obtained by Auto calibration is reflected to the Input 1_PV ratio. Manual full scale point adjustment can be performed by changing this PV ratio.



For this product, in order to generate the R-cal output it is not necessary to short the cables (blue and orange) on the pressure sensor side.

Factory set value: —

STOP display selection	Attribute ID	100 (0x0064)
------------------------	--------------	--------------

STOP message for control STOP mode can be displayed either on the upper display or the lower display. This item is to select the display to show the STOP message.

Attribute: R/W (Read and Write)



This item becomes RO (Read only) during control RUN.

Data range: 0: Displays on the measured value (PV1/PV2) unit (TYPE 1)
1: Displays on the set value (SV) unit (TYPE 2)

Factory set value: 0



There are three different Characters for STOP mode depending on how to be transferred from RUN to STOP.

	(KSTP)	(dSTP)	(SToP)
TYPE1:			
TYPE2:			

Bar graph display selection	Attribute ID	101 (0x0065)
-----------------------------	--------------	--------------

Use to select the contents of the bar graph display.

Attribute: R/W (Read and Write)



This item becomes RO (Read only) during control RUN.

Data range: 0: No display
1: Input 1_manipulated output value (MV)
2: Input 1_measured value (PV)
3: Input 1_set value (SV)
4: Input 1_deviation value
5: Unused (Not available)
6: Input 2_manipulated output value (MV)
7: Input 2_measured value (PV)
8: Input 2_set value (SV)
9: Input 2_deviation value



Factory set value: 0

Related parameters: Bar graph resolution setting (P. 70)

Continued on the next page.

Continued from the previous page.

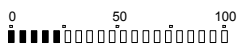
 Bar graph display explanation:

Manipulated output value (MV) display	Displays the Manipulated output value (MV). When Manipulated output value (MV) is at 0 % or less, the left-end dot of the bar-graph flashes. When MV exceeds 100 %, the right-end dot flashes. [Display example] 
Measured value (PV) display	Scaling is available within the input range. [Display example] 
Set value (SV) display	Displays the Set value (SV). Scaling is available within the input range. [Display example] 
Deviation value display	Displays the deviation between the Measured value (PV) and the Set value (SV). When the Deviation display is selected, the dots at both ends of bar-graph light. A display resolution per dot is settable from 1 to 100. [Display example] 

The number of dot points: 10 dots (HA430) 20 dots (HA930)

Bar graph resolution setting	Attribute ID	102 (0x0066)
------------------------------	--------------	--------------

Use to set the bar graph display resolution for the deviation display. However, this set value becomes validated only when the bar graph display selection is “4: Input 1_deviation value” or “9: Input 2_deviation value.”

Attribute: R/W (Read and Write)

 **This item becomes RO (Read only) during control RUN.**

Data range: 1 to 100 digit/dot
Sets several digit per 1 dots of the bar graph.

Factory set value: 100

Related parameters: Bar graph display selection (P. 69)

Auto/Manual transfer key operation selection (A/M)	Attribute ID	104 (0x0068)
--	--------------	--------------

Use to select Use/Unuse of Auto/Manual transfer key (A/M).

Attribute: R/W (Read and Write)

 **This item becomes RO (Read only) during control RUN.**

Data range: 0: Unused
 1: Auto/Manual transfer for input 1
 2: Auto/Manual transfer for input 2
 3: Common Auto/Manual transfer for input 1 and input 2

Factory set value: 3

Remote/Local transfer key operation selection (R/L)	Attribute ID	105 (0x0069)
---	--------------	--------------

Use to select Use/Unuse of Remote/Local transfer key (R/L).

Attribute: R/W (Read and Write)

 **This item becomes RO (Read only) during control RUN.**

Data range: 0: Unused
 1: Remote/Local transfer

Factory set value: 1

RUN/STOP transfer key operation selection (R/S)	Attribute ID	106 (0x006A)
---	--------------	--------------

Use to select Use/Unuse of RUN/STOP transfer key (R/S).

Attribute: R/W (Read and Write)

 **This item becomes RO (Read only) during control RUN.**

Data range: 0: Unused
 1: RUN/STOP transfer

Factory set value: 1

6. COMMUNICATION DATA DESCRIPTION

Input 1_input type selection	Attribute ID	107 (0x006B)
Input 2_input type selection	Attribute ID	117 (0x0075)

Attribute: R/W (Read and Write)



This item becomes RO (Read only) during control RUN.

Data range:

Input 1: 14 to 29 (22, 23: Not available)

[Input Range Table]

Set value	Input type		Input range	Hardware	
19	Voltage (Low) input	0 to 1 V	Programmable range (-19999 to +99999)	Voltage (Low) input group	
20		0 to 100 mV			
21		0 to 10 mV			
24		±100 mV			
25		±10 mV			
14	Current input	0 to 20 mA			
15		4 to 20 mA			
16	Voltage (High) input	0 to 10 V			Voltage (High) input group
17		0 to 5 V			
18		1 to 5 V			
26		±10 V			
27		±5 V			
28		±1 V			
29	Pressure sensor input	Resin Pressure Sensor		0.0 to 250.0 MPa	Pressure group
22	Unused (Not available)				
23					

Input 2: 0 to 28 (22, 23: Not available)

[Input Range Table]

Set value	Input type		Input range	Hardware
0	TC input	K	-200 to +1372 °C or -328.0 to +2501.6 °F	Voltage (Low) input group
1		J	-200 to +1200 °C or -328.0 to +2192.0 °F	
2		R	-50 to +1768 °C or -58.0 to +3214.4 °F	
3		S	-50 to +1768 °C or -58.0 to +3214.4 °F	
4		B	0 to 1800 °C or 32.0 to 3272.0 °F	
5		E	-200 to +1000 °C or -328.0 to +1832.0 °F	
6		N	0 to 1300 °C or 32.0 to 2372.0 °F	
7		T	-200 to +400 °C or -328.0 to +752.0 °F	
8		W5Re/W26Re	0 to 2300 °C or 32.0 to 4172.0 °F	
9		PLII	0 to 1390 °C or 32.0 to 2534.0 °F	
12	RTD input	3-wire system Pt100	-200 to +850 °C or -328.0 to +1562.0 °F	
13		3-wire system JPt100	-200 to +600 °C or -328.0 to +1112.0 °F	
22	Unused (Not available)			
23				

Continued on the next page.

Continued from the previous page.

Set value	Input type		Input range	Hardware			
19	Voltage (Low) input	0 to 1 V	Programmable range (-19999 to +99999)	Voltage (Low) input group			
20		0 to 100 mV					
21		0 to 10 mV					
24		±100 mV					
25		±10 mV					
14	Current input	0 to 20 mA		Programmable range (-19999 to +99999)	Voltage (High) input group		
15		4 to 20 mA					
16	Voltage (High) input	0 to 10 V				Programmable range (-19999 to +99999)	Voltage (High) input group
17		0 to 5 V					
18		1 to 5 V					
26		±10 V					
27		±5 V					
28		±1 V					



An input type change may only be made within the hardware groups as shown above.



Do not set to any number (including 10 and 11) and Input 1 range number (22 or 23) which is not described in the input range table above. This may cause malfunctioning.



Refer to the above input range table to select input type of the Remote input. Input range 0 through 13, 22 or 23 cannot be selected for the Remote input.

Factory set value: Input 1_input type selection: Based on model code
(When not specifying: Pressure sensor input)
Input 2_input type selection: Based on model code
(When not specifying: Type K)

Related parameters: Display unit selection (P. 73), Decimal point position (P. 74),
Input scale high (P. 75), Input scale low (P. 76)

Input 1_display unit selection	Attribute ID	108 (0x006C)
Input 2_display unit selection	Attribute ID	118 (0x0076)

These are the units of display for Input 1 and Input 2.

Attribute: R/W (Read and Write)



This item becomes RO (Read only) during control RUN.

Data range: Input 1_display unit selection: 2: MPa 3: bar 4: kgf/cm² 5: psi



1 MPa = 10 bar = 10.1972 kgf/cm² = 145.038 psi

Input 2_display unit selection: 0: °C 1: °F

Factory set value: Input 1_display unit selection: Pressure sensor input: 2
Voltage (V)/Current (I) inputs: 0

Input 2_display unit selection: 0



The display unit selection becomes invalid when the Voltage/Current input is selected as input type.

Input 1_decimal point position	Attribute ID	109 (0x006D)
Input 2_decimal point position	Attribute ID	119 (0x0077)

Use to select the decimal point position of the input range.

Attribute: R/W (Read and Write)



This item becomes RO (Read only) during control RUN.

Data range: 0: No decimal place 3: Three decimal places
 1: One decimal place 4: Four decimal places
 2: Two decimal places

Input 1_decimal point position:

Pressure Sensor input

Less than 1 (Rated pressure): 0 to 4

Less than 10 MPa (Rated pressure): 0 to 3

Less than 100 MPa (Rated pressure): 0 to 2

100 MPa or more (Rated pressure): 0 or 1

Voltage (V)/Current (I) inputs: 0 to 4

Input 2_decimal point position:

TC inputs: 0 or 1

RTD inputs: 0 to 2

Voltage (V)/Current (I) inputs: 0 to 4

Factory set value: Input 1_decimal point position: 1

Input 2_decimal point position: 1

Related parameters: Input type selection (P. 72), Input scale high (P. 75),
 Input scale low (P. 76)

Input 1_input scale high	Attribute ID	110 (0x006E)
Input 2_input scale high	Attribute ID	120 (0x0078)

This value is high limit of the input scale range.

Attribute: R/W (Read and Write)



This item becomes RO (Read only) during control RUN.

Data range: Pressure sensor input:
Input scale low to Maximum value of the selected input range
TC/RTD inputs:
Input scale low to Maximum value of the selected input range
Voltage (V)/Current (I) inputs:
-19999 to +99999 (Varies with the setting of the decimal point position)

Factory set value: Input 1_input scale high:
Pressure sensor input: 50.0
Voltage (V)/Current (I) inputs: 100.0
Input 2_input scale high:
TC/RTD inputs: Maximum value of the selected input range
Voltage (V)/Current (I) inputs: 100.0

Related parameters: Input type selection (P. 72), Decimal point position (P. 74),
Input scale low (P. 76)

Input Scale High function:

The input scale range can be easily set by setting the Input scale high/low.



When a Voltage/Current input type is selected, the Input scale high can be set lower than the Input scale low. (Input scale high < Input scale low)

Input 1_input scale low	Attribute ID	111 (0x006F)
Input 2_input scale low	Attribute ID	121 (0x0079)

This value is to set the low limit of the input scale range.

Attribute: R/W (Read and Write)



This item becomes RO (Read only) during control RUN.

Data range: Pressure sensor input:
 Minimum value of the selected input range to Input scale high
 TC/RTD inputs:
 Minimum value of the selected input range to Input scale high
 Voltage (V)/Current (I) inputs:
 -19999 to +99999 (Varies with the setting of the decimal point position)

Factory set value: Input 1_input scale low:
 Pressure sensor input: 0.0
 Voltage (V)/Current (I) inputs: 0.0
 Input 2_input scale low:
 TC/RTD inputs: Minimum value of the selected input range
 Voltage (V)/Current (I) inputs: 0.0

Related parameters: Input type selection (P. 72), Decimal point position (P. 74),
 Input scale high (P. 75)

Input Scale Low function:
 Refer to the Input scale high.



When a Voltage/Current input type is selected, the Input scale high can be set lower than the Input scale low. (Input scale high < Input scale low)

Input 1_input error determination point (high)	Attribute ID	112 (0x0070)
Input 2_input error determination point (high)	Attribute ID	122 (0x007A)

Use to set Input error determination point (high). Input error determination function is activated when a measured value reaches the limit, and control output value selected by Action at input error will be output.

Attribute: R/W (Read and Write)



This item becomes RO (Read only) during control RUN.

Data range: Input scale low – (5 % of input span) to Input scale high + (5 % of input span)

Factory set value: Input 1_input error determination point (high):

Pressure sensor input: Input scale high + (5 % of input span)
Voltage (V)/Current (I) inputs: 105.0

Input 2_input error determination point (high):

TC/RTD inputs: Input scale high + (5 % of input span)
Voltage (V)/Current (I) inputs: 105.0

Related parameters: Input error determination point (low) (P. 78),
Action at input error (high) (P. 101),
Action at input error (low) (P. 102),
Manipulated output value at input error (P. 102)



[Example] When the input scale is 0.0 to 250.0:

Input span: 250.0

5 % of input span: 12.5

Setting range: -12.5 to +262.5

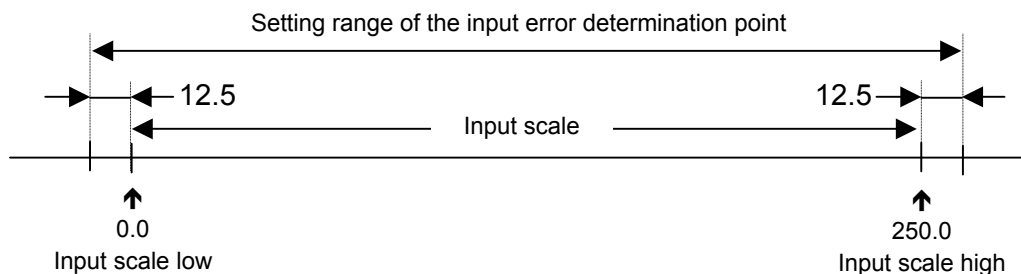

Input 1_input error determination point (low)	Attribute ID	113 (0x0071)
Input 2_input error determination point (low)	Attribute ID	123 (0x007B)

Use to set Input error determination point (low). Input error determination function is activated when a measured value reaches the limit, and control output value selected by Action at input error will be output.

Attribute: R/W (Read and Write)



This item becomes RO (Read only) during control RUN.

Data range: Input scale low – (5 % of input span) to Input scale high + (5 % of input span)

Factory set value: Input 1_input error determination point (low):

Pressure sensor input: Input scale low – (5 % of input span)

Voltage (V)/Current (I) inputs: –5.0

Input 2_input error determination point (low):

TC/RTD inputs: Input scale low – (5 % of input span)

Voltage (V)/Current (I) inputs: –5.0

Related parameters: Input error determination point (high) (P. 77),
Action at input error (high) (P. 101),
Action at input error (low) (P. 102),
Manipulated output value at input error (P. 102)

Input 1_burnout direction	Attribute ID	114 (0x0072)
Input 2_burnout direction	Attribute ID	124 (0x007C)

Use to select Burnout direction in input break. When input break is detected by the controller, the measured value go either Upscale or Downscale according to the Burnout direction setting.

Attribute: R/W (Read and Write)



This item becomes RO (Read only) during control RUN.

Data range: Pressure sensor input: 0 (Upscale), 1 (Downscale)
 TC input: 0 (Upscale), 1 (Downscale)
 RTD input: 0 (Upscale)
 Voltage (Low) input: 0 (Upscale), 1 (Downscale)
 Voltage (High) input: 1 (Downscale)
 Current (I) input: 1 (Downscale)

Factory set value: Input 1_burnout direction: 0 (Upscale)
 Input 2_burnout direction: 0 (Upscale)



The action in the input breaks fix regardless of setting a Burnout direction about the following input.

- **RTD inputs:** Upscale
- **Voltage (High) inputs:** Downscale (Indicates value near 0 V.)
- **Current (I) inputs:** Downscale (Indicates value near 0 mA.)

Input 1_square root extraction selection	Attribute ID	115 (0x0073)
Input 2_square root extraction selection	Attribute ID	125 (0x007D)

Use to select Use/Unuse of the square root extraction for the measured value.

Attribute: R/W (Read and Write)



This item becomes RO (Read only) during control RUN.

Data range: 0: Unused
1: Used

Factory set value: Input 1_square root extraction selection: 0
Input 2_square root extraction selection: 0

Related parameters: Input 1_PV low input cut-off (P. 61), Input 2_PV low input cut-off (P. 61)

Square root extraction function:

The controller can receive the input signal directly from a differential pressure type flow transmitter by using Square root extraction function without using a square root extractor.

Power supply frequency selection	Attribute ID	116 (0x0074)
----------------------------------	--------------	--------------

Use to select the power supply frequency of the controller suited to the application.

Attribute: R/W (Read and Write)



This item becomes RO (Read only) during control RUN.

Data range: 0: 50 Hz
1: 60 Hz

Factory set value: 0

Event input logic selection	Attribute ID	126 (0x007E)
-----------------------------	--------------	--------------

Use to assign the function (memory area, operation mode) for the event inputs (DI 1 to DI 5).

Attribute: R/W (Read and Write)



This item becomes RO (Read only) during control RUN.

Data range: 0 to 15 (refer to the following table)

[Function Assignment Table]

Set value	DI 1	DI 2	DI 3	DI 4	DI 5
	Terminal No. 30-31	Terminal No. 30-32	Terminal No. 30-33	Terminal No. 30-34	Terminal No. 35-36
0	Unused (No function assignment)				
1	Memory area number selection (1 to 16)				Memory area set
2	Memory area number selection (1 to 16)				Memory area set
3	Memory area number selection (1 to 16)				Memory area set
4	Memory area number selection (1 to 8)			Memory area set	RUN/STOP transfer
5	Memory area number selection (1 to 8)			Memory area set	Remote/Local transfer
6	Memory area number selection (1 to 8)			Memory area set	Auto/Manual transfer
7	Memory area number selection (1 to 8)			Memory area set	Hold reset
8	Memory area number selection (1 to 8)			Memory area set	Interlock release
9	Memory area number selection (1 to 4)		Memory area set	RUN/STOP transfer	Auto/Manual transfer
10	Memory area number selection (1 to 4)		Memory area set	RUN/STOP transfer	Remote/Local transfer
11	Memory area number selection (1 to 4)		Memory area set	Remote/Local transfer	Auto/Manual transfer
12	Memory area number selection (1 to 4)		Memory area set	Hold reset	Interlock release
13	Auto/Manual transfer	RUN/STOP transfer	Remote/Local transfer	Hold reset	Interlock release
14	Auto/Manual transfer	Input 1_manual output down (motor RPM down) ¹	Input 1_manual output up (motor RPM up) ²	Input 1_manual output 0% reset (motor RPM reset) ³	RUN/STOP transfer
15	Auto/Manual transfer	Input 2_manual output down (motor RPM down) ¹	Input 2_manual output up (motor RPM up) ²	Input 2_manual output 0% reset (motor RPM reset) ³	RUN/STOP transfer

¹ Decreases manipulated output value (motor RPM) under Manual control with contacts closed.

² Increases manipulated output value (motor RPM) under Manual control with contacts closed.

³ The manipulated output value (motor RPM) is reset to 0% based on the edge discrimination of "open" to "closed." In addition, switched to "Manual Control" regardless of Auto/Manual transfer setting.



Event input terminals

Dry contact input

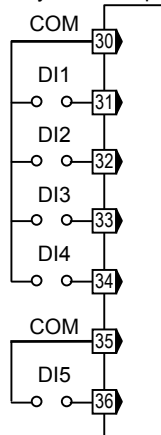

Contact input from external devices or equipment should be dry contact input. If it is not dry contact input, the input should meet the specification below.

Contact resistance: At OFF (contact open) 500 k Ω or more
At ON (contact closed) 10 Ω or less

Continued on the next page.

Continued from the previous page.

Factory set value: 1

Event input function: Refer to below.

● Contact status of memory area number selection



To store a new Memory area number as the Control area, close the DI for Memory area set.

Event input	Memory area number															
	1	2	3	4	5	6	7	8	9	10	11	12	13	14	15	16
DI 1	x	-	x	-	x	-	x	-	x	-	x	-	x	-	x	-
DI 2	x	x	-	-	x	x	-	-	x	x	-	-	x	x	-	-
DI 3	x	x	x	x	-	-	-	-	x	x	x	x	-	-	-	-
DI 4	x	x	x	x	x	x	x	x	-	-	-	-	-	-	-	-

x: Contact open -: Contact closed

Transfer timing of memory area number:

[Example] Change the memory area number to 6
(when “4” is selected in “Event input logic selection”)

First, close the contacts between DI1 and DI3 and the common terminal. Next, open the contact between DI2 and the common. Then, close the contact between DI4 and the common from open status, the memory area in the controller will change to “6.”

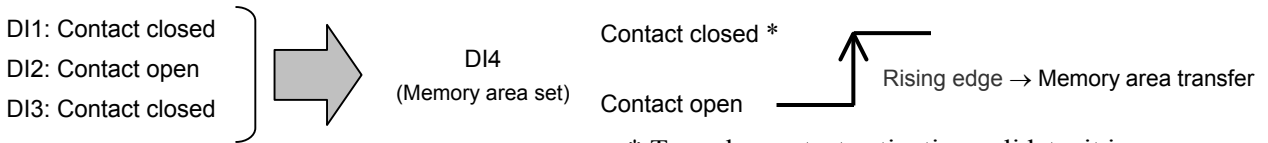

* To make contact activation validate, it is necessary to maintain the same contact state (contact closed) for more than 200 ms.

● Relationship between contact state and each operation state

	Contact closed	Contact open	No event input or not selected
RUN/STOP transfer	RUN (Control RUN)	STOP (Control STOP)	RUN (Control RUN)
Auto/Manual transfer	Auto	Manual	Auto
Remote/Local transfer	Remote or cascade control	Local	Local
Hold reset	Hold reset execution	—	By key operation
Interlock release	Interlock release execution	—	
Manual output down (Motor RPM down) ¹	Manual output down (Motor RPM down)	—	
Manual output up (Motor RPM up) ²	Manual output up (Motor RPM up)	—	—
Manual output 0 % reset (Motor RPM reset) ³	Manual output 0 % reset (Motor RPM reset)	—	

¹ Decreases manipulated output value (motor RPM) under Manual control with contacts closed.

² Increases manipulated output value (motor RPM) under Manual control with contacts closed.

³ The manipulated output value (motor RPM) is reset to 0 % based on the edge discrimination of “open” to “closed.” In addition, switched to “Manual Control” regardless of Auto/Manual transfer setting.

Continued on the next page.

Continued from the previous page.

● **RUN/STOP transfer**

Mode select from front key or communication	Status of event input (DI)	Actual operation mode
RUN (Control RUN)	Contact closed	RUN (Control RUN)
	Contact open	
STOP (Control STOP)	Contact closed	STOP (Control STOP)
	Contact open	

● **Auto/Manual transfer**

Mode select from front key or communication	Status of event input (DI)	Actual operation mode
Auto	Contact closed	Auto
	Contact open	
Manual	Contact closed	Manual
	Contact open	

● **Remote/Local transfer**

Mode select from front key or communication	Status of event input (DI)	Actual operation mode
Remote	Contact closed	Remote
	Contact open	
Local	Contact closed	Local
	Contact open	

Transfer timing of RUN/STOP, Auto/Manual, and Remote/Local:

The selection operation is taken when DI contact is closed from the open condition (Rising edge).

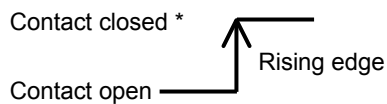

* To make contact activation validate, it is necessary to maintain the same contact state (contact closed) for more than 200 ms.

Output logic selection	Attribute ID	127 (0x007F)
------------------------	--------------	--------------

This is used to assign the output function (control output, event, etc.) for the output (OUT1 to OUT5).

Attribute: R/W (Read and Write)

 **This item becomes RO (Read only) during control RUN.**

Data range: 3 to 8, 11 (refer to the following table)
1, 2, 9 and 10: Unused (Not available)

(M: Relay contact output, V: Voltage pulse output, R: Current output, E: Voltage, T: Triac output)

Set value	OUT1 (M/ V / R/ E/ T)	OUT2 (M/ V/ R/ E/ T)	OUT3 (M/ V/ R/ E/ T)	OUT4 (M)	OUT5 (M)	Remarks	
1	This set value is not used for the HA430/930.						—
2	This set value is not used for the HA430/930.						—
3	MV 1	EV 3 (Energized) or EV 4 (Energized)	EV 2 (Energized)	EV 1 (Energized)	FAIL (De-energized)	Energized alarm corresponding to FAIL output	
4	MV 1	EV 3 (De-energized) or EV 4 (De-energized)	EV 2 (De-energized)	EV 1 (De-energized)	FAIL (De-energized)	De-energized alarm corresponding to FAIL output	
5	MV 1	MV 2	EV 4 (Energized)	EV 3 (Energized)	EV 1 (Energized) or EV2 (Energized)	Energized alarm corresponding to two loops control	
6	MV 1	MV 2	EV 4 (De-energized)	EV 3 (De-energized)	EV 1 (De-energized) or EV 2 (De-energized)	De-energized alarm corresponding to two loops control	
7	MV 1	MV 2	EV 3 (Energized) or EV 4 (Energized)	EV 2 (Energized)	EV 1 (Energized)	Energized alarm corresponding to two loops control	
8	MV 1	MV 2	EV 3 (De-energized) or EV 4 (De-energized)	EV 2 (De-energized)	EV 1 (De-energized)	De-energized alarm corresponding to two loops control	
9	This set value is not used for the HA430/930.						—
10	This set value is not used for the HA430/930.						—
11	MV 1	EV 4 (Energized)	EV 3 (Energized)	EV 2 (Energized)	EV 1 (Energized)	Energized alarm	

MV 1 = Manipulated output value of Input 1, MV 2 = Manipulated output value of Input 2,
EV 1 = Output of Event 1, EV 2 = Output of Event 2, EV 3 = Output of Event 3, EV 4 = Output of Event 4, FAIL = FAIL output

 An output logic becomes *OR* output when two or more output functions are assigned to one output.

 When three transmission outputs are selected, the transmission outputs are automatically assigned to OUT1 through OUT3 and it has priority over the Output logic selection. To select Manipulated output value of Input 1 or Input 2 as output type of OUT1, OUT2 or OUT3, select “4: Input 1_manipulated output value (MV)” or “8: Input 2_manipulated output value (MV)” at the parameters of Transmission output type selection.

Transmission output type	Assign location of output
Transmission output 1	Output 1 (OUT1)
Transmission output 2	Output 2 (OUT2)
Transmission output 3	Output 3 (OUT3)

Continued on the next page.

Continued from the previous page.



The OUT3 output terminals (Nos. 7 and 8) are used when any sensor power supply is specified. The use of this function disables the use of OUT3 to OUT5 as control output, event output and transmission output. In addition, the number of transmission output points becomes 2 maximum.

Factory set value: For 1-input controller: 3
For 2-input controller: 5

Related parameters: Output timer setting (P. 86), Transmission output type selection (P. 87),
Event input logic selection (P. 81),
Alarm lamp lighting condition setting (P. 112)

Output 1 timer setting	Attribute ID	128 (0x0080)
Output 2 timer setting	Attribute ID	129 (0x0081)
Output 3 timer setting	Attribute ID	130 (0x0082)
Output 4 timer setting	Attribute ID	131 (0x0083)
Output 5 timer setting	Attribute ID	132 (0x0084)

Output timer setting is to set an output delay time for event outputs.

Attribute: R/W (Read and Write)

 **This item becomes RO (Read only) during control RUN.**

Data range: 0.0 to 600.0 seconds

Factory set value: 0.0

Related parameters: Output logic selection (P. 84), Event type selection (P. 89),
Alarm lamp lighting condition setting (P. 112)

Output timer setting function:

When an event condition becomes ON status, the output is suppressed until the Output timer set time elapses. After the time is up, if the event output is still ON status, the output will be produced.

Example: When set the event timer to 100.0 seconds.

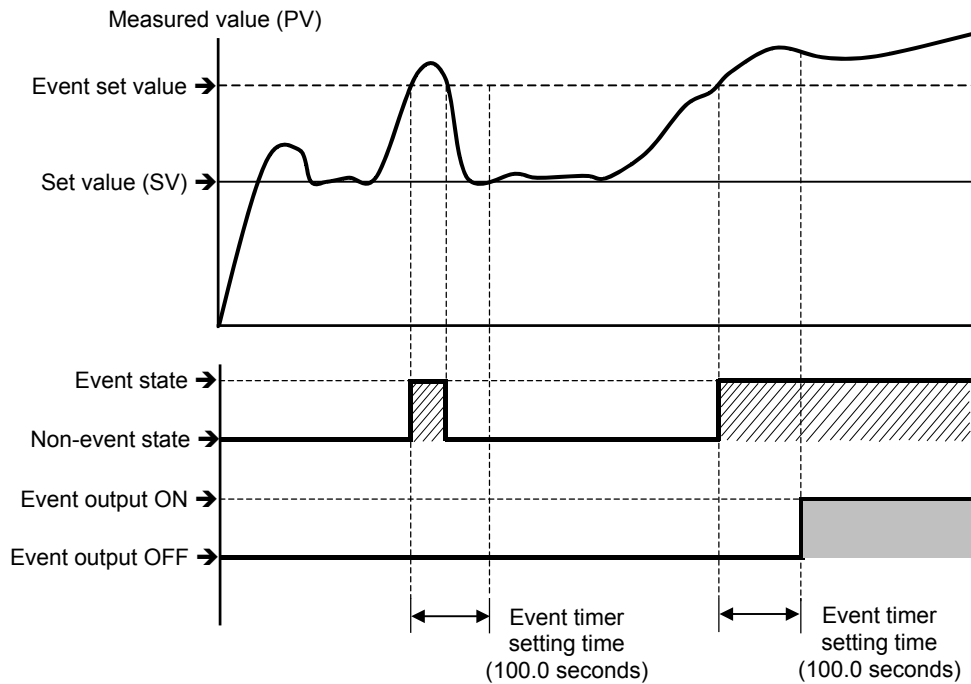

Transmission output 1_type selection	Attribute ID	133 (0x0085)
Transmission output 2_type selection	Attribute ID	136 (0x0088)
Transmission output 3_type selection	Attribute ID	139 (0x008B)

Use to select the transmission output type.

Attribute: R/W (Read and Write)



This item becomes RO (Read only) during control RUN.

Data range: 0: None
 1: Input 1_measured value (PV)
 2: Input 1_set value (SV)
 3: Input 1_deviation value
 4: Input 1_manipulated output value (MV)
 5: Input 2_measured value (PV)
 6: Input 2_set value (SV)
 7: Input 2_deviation value
 8: Input 2_manipulated output value (MV)
 9: Unused (Not available)

Factory set value: 0

Related parameters: Transmission output scale high (P. 88),
 Transmission output scale low (P. 88)



Specify the output type of the transmission output when ordering.



When transmission outputs are selected and used, the outputs are allocated as follows.

- Transmission output 1: Output 1 (OUT1)
- Transmission output 2: Output 2 (OUT2)
- Transmission output 3: Output 3 (OUT3)



The transmission has priority over the Output logic selection.

Transmission output 1_scale high	Attribute ID	134 (0x0086)
Transmission output 2_scale high	Attribute ID	137 (0x0089)
Transmission output 3_scale high	Attribute ID	140 (0x008C)

Use to set a scale high limit value of the transmission output.

Attribute: R/W (Read and Write)



This item becomes RO (Read only) during control RUN.

Data range: Measured value (PV) and Set value (SV): Input scale low to Input scale high
 Manipulated output value (MV): -5.0 to +105.0 %
 Deviation: -Input span to +Input span

Factory set value: Measured value (PV) and Set value (SV): Input scale high
 Manipulated output value (MV): 100.0
 Deviation: + Input span

Related parameters: Transmission output type selection (P. 87),
 Transmission output scale low (P. 88)

Transmission output 1_scale low	Attribute ID	135 (0x0087)
Transmission output 2_scale low	Attribute ID	138 (0x008A)
Transmission output 3_scale low	Attribute ID	141 (0x008D)

Use to set a scale low limit value of the transmission output.

Attribute: R/W (Read and Write)



This item becomes RO (Read only) during control RUN.

Data range: Measured value (PV) and Set value (SV): Input scale low to Input scale high
 Manipulated output value (MV): -5.0 to +105.0 %
 Deviation: -Input span to +Input span

Factory set value: Measured value (PV) and Set value (SV): Input scale low
 Manipulated output value (MV): 0.0
 Deviation: - Input span

Related parameters: Transmission output type selection (P. 87),
 Transmission output scale high (P. 88)

Event 1 type selection	Attribute ID	142 (0x008E)
Event 2 type selection	Attribute ID	147 (0x0093)
Event 3 type selection	Attribute ID	152 (0x0098)
Event 4 type selection	Attribute ID	157 (0x009D)

Use to select a type of the event 1, 2, 3 and 4.

Attribute: R/W (Read and Write)



This item becomes RO (Read only) during control RUN.

Data range: 0: None
 1: Deviation high ¹
 2: Deviation low ¹
 3: Deviation high/low ¹
 4: Band ¹
 5: Process high ¹
 6: Process low ¹
 7: SV high
 8: SV low
 9: Control loop break alarm (LBA) ²

¹ Event hold action is available.

² The "9: Control loop break alarm (LBA)" can be selected only for Event 3 and Event 4.

Factory set value: 0

Related parameters: Event set value (P. 49), Control loop break alarm (LBA) time (P. 50), LBA deadband (P. 50), Output logic selection (P. 84), Output timer setting (P. 86), Event hold action (P. 91), Event differential gap (P. 93), Event action at input error (P. 94), Event assignment (P. 95), Alarm lamp lighting condition setting (P. 112)

Functional description: Refer to the next page.

Continued on the next page.

Continued from the previous page.

● Event action type

Deviation high:

(Event set value is greater than 0.)

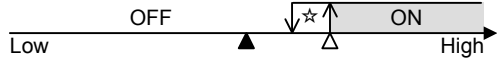

Deviation low:

(Event set value is greater than 0.)



Deviation high/low:

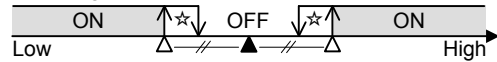

Process high:

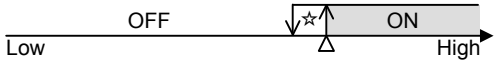

SV high:

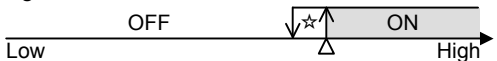

(▲ : Set value (SV) Δ : Event set value ☆ : Event differential gap)

(Event set value is less than 0.)



(Event set value is less than 0.)

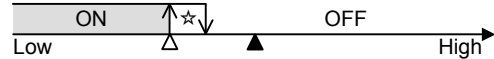

Band:

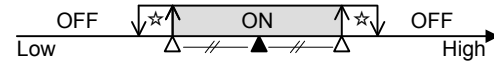

Process low:

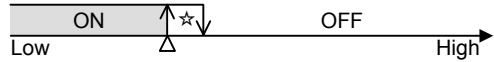

SV low:

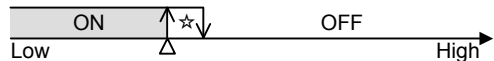

● Control loop break alarm (LBA)

The control loop break alarm (LBA) function is used to detect a load (heater) break or a failure in the external actuator (power controller, magnet relay, etc.), or a failure in the control loop caused by an input (sensor) break. The LBA function is activated when control output reaches 0 % (low limit with output limit function) or 100 % (high limit with output limit function). LBA monitors variation of the Measured value (PV) for the length of LBA time. When the LBA time has elapsed and the PV is still within the alarm determination range, the LBA will be ON.

[Alarm action]

The LBA function produces the alarm when any of the following conditions occurs.

LBA determination range: Temperature input: 2 °C [2 °F] (fixed)

Pressure sensor input and Voltage/Current input:

0.2 % of input span (fixed)

● When the control output reaches 0 % (low limit with output limit function)

For direct action: When the LBA time has passed and the PV has not risen beyond the alarm determination range, the alarm will be turned on.

For reverse action: When the LBA time has passed and the PV has not fallen below the alarm determination range, the alarm will be turned on.





● When the output exceeds 100 % (low limit with output high function)

For direct action: When the LBA time has passed and the PV has not fallen below the alarm determination range, the alarm will be turned on.

For reverse action: When the LBA time has passed and the PV has not risen beyond the alarm determination range, the alarm will be turned on.

Continued on the next page.

Continued from the previous page.

-  If the Autotuning function is used, the LBA time is automatically set twice as large as the integral time. The LBA setting time will not be changed even if the integral time is changed.
-  LBA function is not operative when:
 - AT function is activated.
 - The controller is in STOP mode.
 - LBA function is set to “0.”
 - LBA function is not assigned to Event 3 or Event 4.
-  The LBA function does not detect a location which causes alarm status. If LBA alarm is ON, check each device or wiring of the control loop.
-  While the LBA is ON (under alarm status), the following conditions cancel the alarm status and LBA will be OFF:
 - The Measured value (PV) rises beyond (or falls below) the LBA determination range within the LBA time.
 - The Measured value (PV) enters within the LBA deadband.

Event 1 hold action	Attribute ID	143 (0x008F)
Event 2 hold action	Attribute ID	148 (0x0094)
Event 3 hold action	Attribute ID	153 (0x0099)
Event 4 hold action	Attribute ID	158 (0x009E)

Use to set an event hold action for the Event 1, 2, 3 or 4.

-  **When high alarm with Hold/Re-hold action is used for Event function, alarm does not turn on while Hold action is in operation. Use in combination with a high alarm without Hold action in order to prevent overheating which may occur by failure of control devices, such as welding of relays.**

Attribute: R/W (Read and Write)

 **This item becomes RO (Read only) during control RUN.**

Data range: 0: OFF
1: ON
2: Re-hold action ON

Factory set value: 0

Related parameters: Event set value (P. 49), Event type selection (P. 89),
Event differential gap (P. 93), Event action at input error (P. 94),
Event assignment (P. 95)

Functional description: Refer to the next page.

Continued on the next page.

Continued from the previous page.

● **Hold action**

When Hold action is ON, the event action is suppressed at start-up or STOP to RUN until the measured value has entered the non-event range.

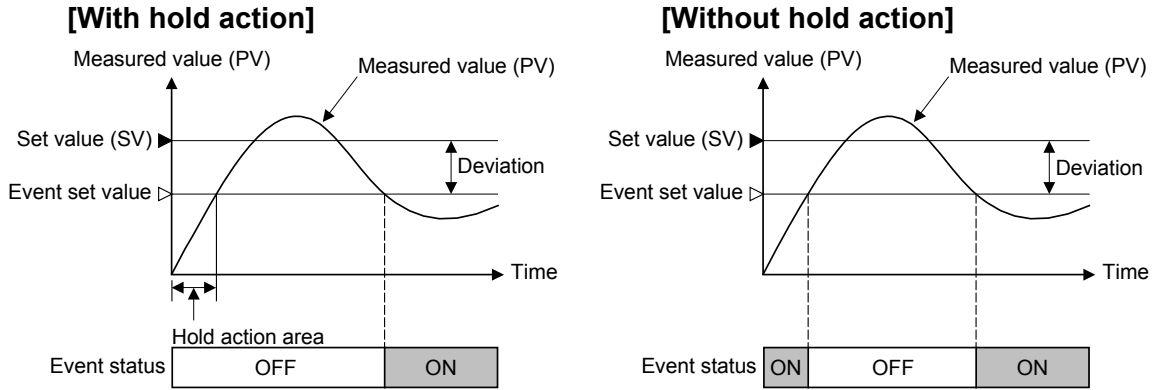

● **Re-hold action**

When Re-hold action is ON, the event action is also suppressed at the control set value change until the measured value has entered the non-event range.

Action condition	1: Hold action ON (Only Hold action)	2: Re-hold action ON (Hold and Re-hold actions)
When the power is turned on	Hold action	Hold action
When transferred from STOP (control STOP) to RUN (control RUN)	Hold action	Hold action
When the Set value (SV) is changed	Without Hold and Re-hold actions	Re-hold action



The Re-hold action is invalidated for any of the following. However, the Hold action is validated.

- When Setting change rate limiter other than “OFF (Unused)” are set
- When Remote/Local transfer is the remote mode

[Example] When Event 1 type is the deviation low:

When Re-hold action is OFF and event output type is deviation, the event output is produced due to the Set value change. The Re-hold action suppresses the alarm output until the measured value has entered the non-event range again.

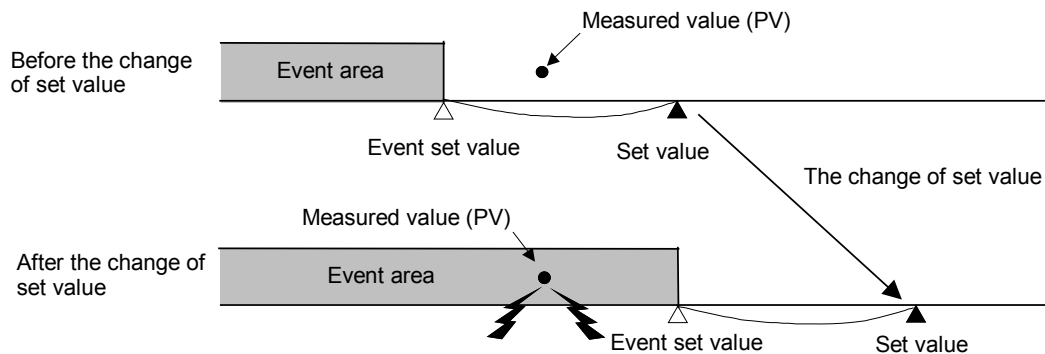

Event 1 differential gap	Attribute ID	144 (0x0090)
Event 2 differential gap	Attribute ID	149 (0x0095)
Event 3 differential gap	Attribute ID	154 (0x009A)
Event 4 differential gap	Attribute ID	159 (0x009F)

Use to set a differential gap of the Event 1, 2, 3 or 4.

Attribute: R/W (Read and Write)



This item becomes RO (Read only) during control RUN.

Data range: 0 to Input span
(Varies with the setting of the Decimal point position)

Factory set value: Pressure sensor input [Input 1]: 2.0 MPa
TC/RTD inputs [Input 2]: 2.0 °C [°F]
Voltage (V)/Current (I) inputs [Input 1, Input 2]: 0.2 % of input span

Related parameters: Event set value (P. 49), Event type selection (P. 89),
Event hold action (P. 91), Event action at input error (P. 94),
Event assignment (P. 95)

Event differential gap function:

It prevents chattering of event output due to the measured value fluctuation around the event set value.

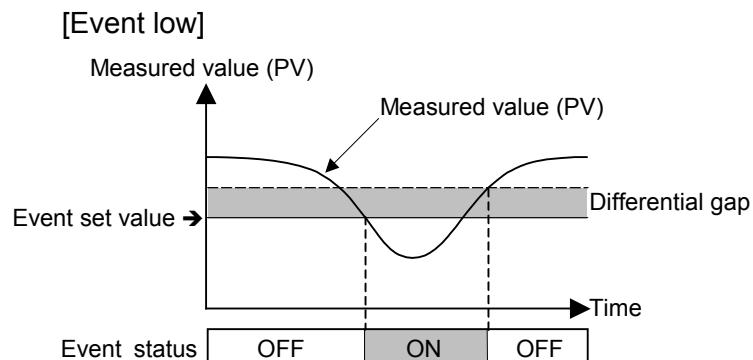
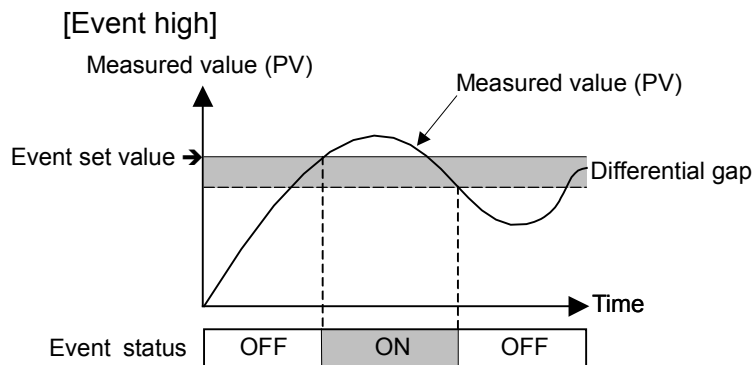

Event 1 action at input error	Attribute ID	145 (0x0091)
Event 2 action at input error	Attribute ID	150 (0x0096)
Event 3 action at input error	Attribute ID	155 (0x009B)
Event 4 action at input error	Attribute ID	160 (0x00A0)

Event action at input error is to select the event action when the measured value reaches the Input error determination point (high or low limit).

Attribute: R/W (Read and Write)

 **This item becomes RO (Read only) during control RUN.**

Data range: 0: Normal processing
1: Turn the event output ON

Factory set value: 0

Related parameters: Input error determination point (high) (P. 77),
Input error determination point (low) (P. 78)

Event action at input error:

Example: Input range: 0.0 to 250.0 MPa
Input error determination point (high): 240.0 MPa
Input error determination point (low): 5.0 MPa

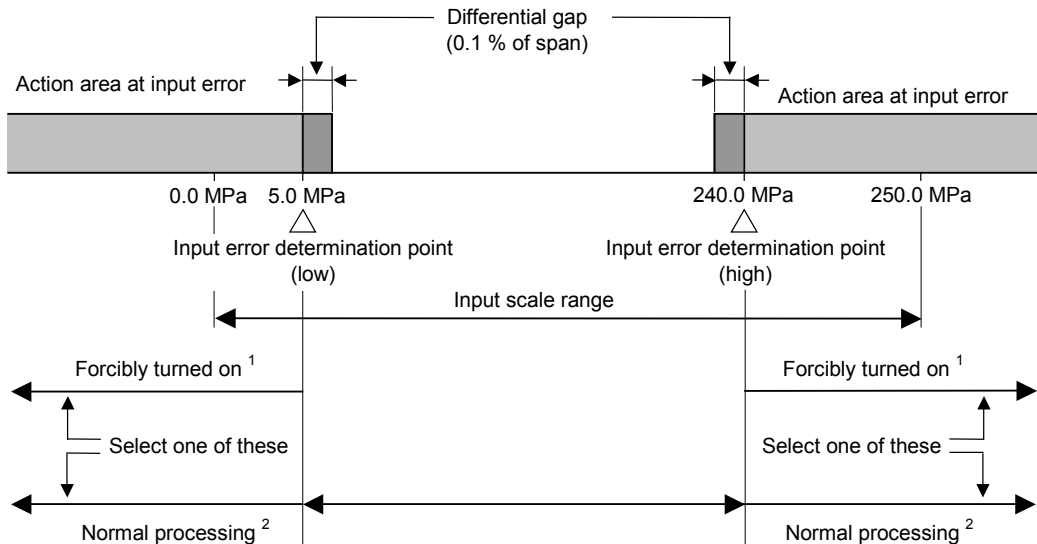

¹ The event output is forcibly turned on regardless of the selected event action status when the input is abnormal.

² The event output is produced depending on the selected event action status even if the input is abnormal.

Event 1 assignment	Attribute ID	146 (0x0092)
Event 2 assignment	Attribute ID	151 (0x0097)
Event 3 assignment	Attribute ID	156 (0x009C)
Event 4 assignment	Attribute ID	161 (0x00A1)

Use to assign event outputs to either Input 1 or Input 2.

Attribute: R/W (Read and Write)

 **This item becomes RO (Read only) during control RUN.**

Data range: 1: For input 1
2: For input 2

Factory set value: 1

Related parameters: Event set value (P. 49), Event type selection (P. 89), Event hold action (P. 91), Event differential gap (P. 93), Event action at input error (P. 94)

Hot/Cold start selection	Attribute ID	166 (0x00A6)
--------------------------	--------------	--------------

Use to select the start mode at power recovery.

Attribute: R/W (Read and Write)

 **This item becomes RO (Read only) during control RUN.**

Data range: 0 to 5 (refer to the following table)

Set value	Power failure less than 3 seconds	Power failure 3 seconds or more
0	Hot start 1	Hot start 1
1	Hot start 1	Hot start 2
2	Hot start 1	Cold start
3	Hot start 2	Hot start 2
4	Hot start 2	Cold start
5	Cold start	Cold start
6	Hot start 1	Stop start
7	Hot start 2	Stop start
8	Stop start	Stop start

Factory set value: 5

Hot/Cold start function: After the power failure, when power is back to the controller,

Hot start 1: the controller will return to the same operation mode and the same manipulated value which were used or calculated by the controller before power failure.

Hot start 2: the controller will return to the same operation mode which was used by the controller before power failure.

- In the Manual mode, the output value will be at the low output limit value.
- In the Auto mode, the controller will calculate the manipulated output value regardless that before power failure. So, the manipulated output varies.

Cold start: the controller will automatically go to Manual mode and output the low output limit value.

Stop start: Started in the control stop (STOP) state regardless of the RUN mode (Auto/Manual) before power failure. Set to the RUN mode before power failure when changed to RUN from STOP by RUN/STOP selection.

Input 2_use selection	Attribute ID	167 (0x00A7)
-----------------------	--------------	--------------

Use to select the usage of Input 2.

Attribute: R/W (Read and Write)

 **This item becomes RO (Read only) during control RUN.**

Data range: 0: Single loop control
1: Remote input

Factory set value: 0

SV tracking	Attribute ID	170 (0x00AA)
-------------	--------------	--------------

To select Use/Unuse of SV tracking.

Attribute: R/W (Read and Write)

 **This item becomes RO (Read only) during control RUN.**

Data range: 0: Unused
1: Used

Factory set value: 1

SV Tracking function: With SV Tracking function, when Remote/Local mode is transferred from Remote to Local, the set value used in Remote mode before the mode transfer will be kept using in Local mode to prevent rapid set value change.

Operation mode:	Local	→	Remote	→	Local
Set value used	Local set value		Remote set value		Local set value
SV tracking used	Local set value ≠ Remote set value		Local set value = Remote set value		Local set value = Remote set value
SV tracking unused	Local set value ≠ Remote set value		Local set value ≠ Remote set value		Local set value ≠ Remote set value

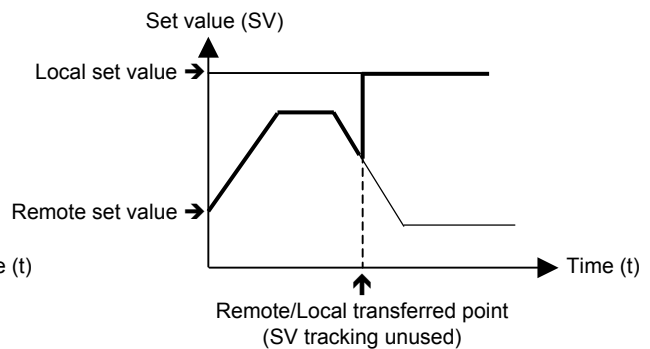
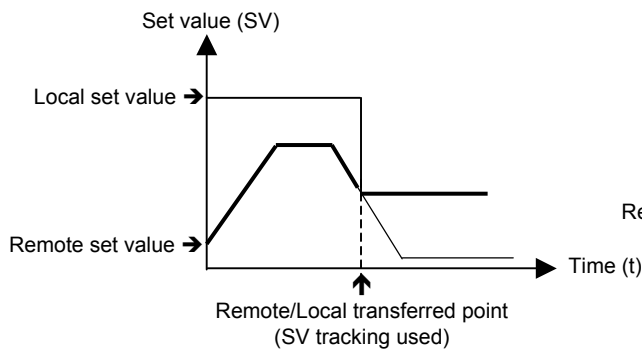

Input 1_control action type selection	Attribute ID	171 (0x00AB)
Input 2_control action type selection	Attribute ID	184 (0x00B8)

Use to select Direct action/Reverse action.

Attribute: R/W (Read and Write)



This item becomes RO (Read only) during control RUN.

Data range: 0: Direct action
1: Reverse action

Factory set value: Input 1_control action type selection: 1
Input 2_control action type selection: 1

Control action type: Direct action: The Manipulated output value (MV) increases as the Measured value (PV) increases. This action is used generally for cool control.

Reverse action: The Manipulated output value (MV) decreases as the Measured value (PV) increases. This action is used generally for heat control.

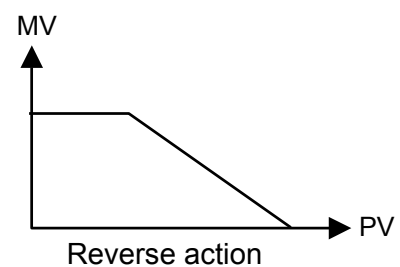
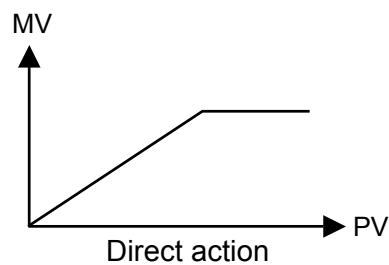

Input 1_integral/derivative time decimal point position selection	Attribute ID	172 (0x00AC)
Input 2_integral/derivative time decimal point position selection	Attribute ID	185 (0x00B9)

Use to select a decimal point position of Integral time and Derivative time in PID control.

Attribute: R/W (Read and Write)

 **This item becomes RO (Read only) during control RUN.**

Data range: 0: No decimal place
1: One decimal place
2: Two decimal places

Factory set value: Input 1_integral/derivative time decimal point position selection: 2
Input 2_integral/derivative time decimal point position selection: 2

Related parameters: Integral time (P. 53), Derivative time (P. 54)

Input 1_derivative gain	Attribute ID	173 (0x00AD)
Input 2_derivative gain	Attribute ID	186 (0x00BA)

Use to set a gain used for derivative action in PID control. Derivative gain should not be changed under ordinary operation.

Attribute: R/W (Read and Write)

 **This item becomes RO (Read only) during control RUN.**

Data range: 0.1 to 10.0

Factory set value: Input 1_derivative gain: 6.0
Input 2_derivative gain: 6.0

 Under ordinary operation, it is not necessary to change Derivative gain set value.

Input 1_ON/OFF action differential gap (upper)	Attribute ID	174 (0x00AE)
Input 2_ON/OFF action differential gap (upper)	Attribute ID	187 (0x00BB)

Use to set the ON/OFF control differential gap (upper).

Attribute: R/W (Read and Write)



This item becomes RO (Read only) during control RUN.

Data range: 0 to Input span
(Varies with the setting of the Decimal point position)

Factory set value: Input 1_ON/OFF action differential gap (upper):
 Pressure sensor input: 1.0 MPa
 Voltage (V)/Current (I) inputs: 0.1 % of input span
 Input 2_ON/OFF action differential gap (upper):
 TC/RTD inputs: 1.0 °C [°F]
 Voltage (V)/Current (I) inputs: 0.1 % of input span

Related parameters: ON/OFF action differential gap (lower) (P. 100)

ON/OFF action differential gap:

Refer to the ON/OFF action differential gap (lower).

Input 1_ON/OFF action differential gap (lower)	Attribute ID	175 (0x00AF)
Input 2_ON/OFF action differential gap (lower)	Attribute ID	188 (0x00BC)

Use to set the ON/OFF control differential gap (lower).

Attribute: R/W (Read and Write)



This item becomes RO (Read only) during control RUN.

Data range: 0 to Input span
(Varies with the setting of the Decimal point position)

Factory set value: Input 1_ON/OFF action differential gap (lower):
 Pressure sensor input: 1.0 MPa
 Voltage (V)/Current (I) inputs: 0.1 % of input span
 Input 2_ON/OFF action differential gap (lower):
 TC/RTD inputs: 1.0 °C [°F]
 Voltage (V)/Current (I) inputs: 0.1 % of input span

Related parameters: ON/OFF action differential gap (upper) (P. 99)

ON/OFF action differential gap:

ON/OFF control is possible when the proportional band is set to “0” or “0.0.” In ON/OFF control with Reverse action, when the Measured value (PV) is smaller than the Set value (SV), the Manipulated output (MV) is 100 % or ON. When the PV is higher than the SV, the MV is 0 % or OFF. Differential gap setting prevents control output from repeating ON and OFF too frequently.

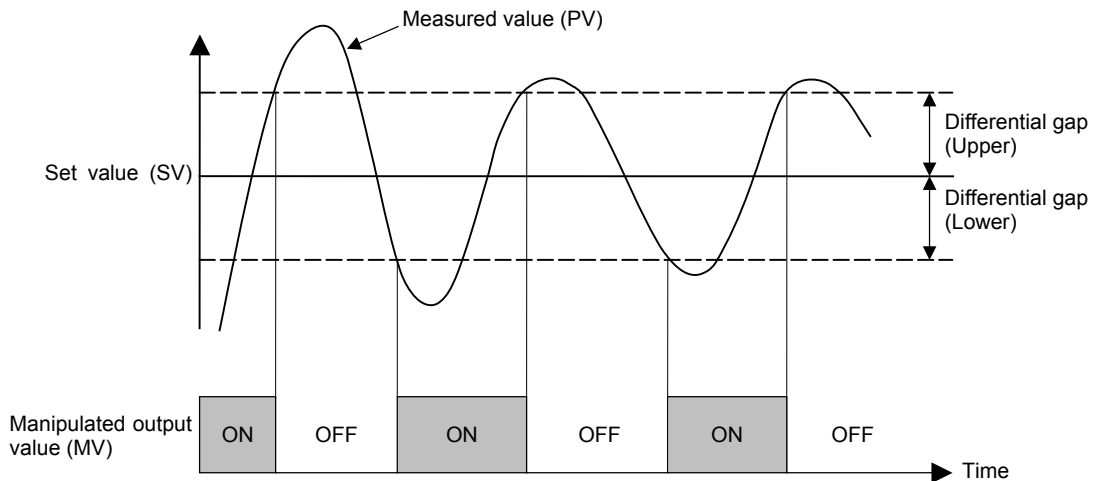

Input 1_action at input error (high)	Attribute ID	176 (0x00B0)
Input 2_action at input error (high)	Attribute ID	189 (0x00BD)

Use to select the action when the measured value reaches the Input error determination point (high).

Attribute: R/W (Read and Write)



This item becomes RO (Read only) during control RUN.

Data range: 0: Normal control
1: Manipulated output value at input error

Factory set value: Input 1_action at input error (high): 0
Input 2_action at input error (high): 0

Related parameters: Input error determination point (high) (P. 77),
Manipulated output value at input error (P. 102)

Input error determination:

Example: Input range: 0.0 to 250.0 MPa
Input error determination point (high): 240.0 MPa
Input error determination point (low): 5.0 MPa

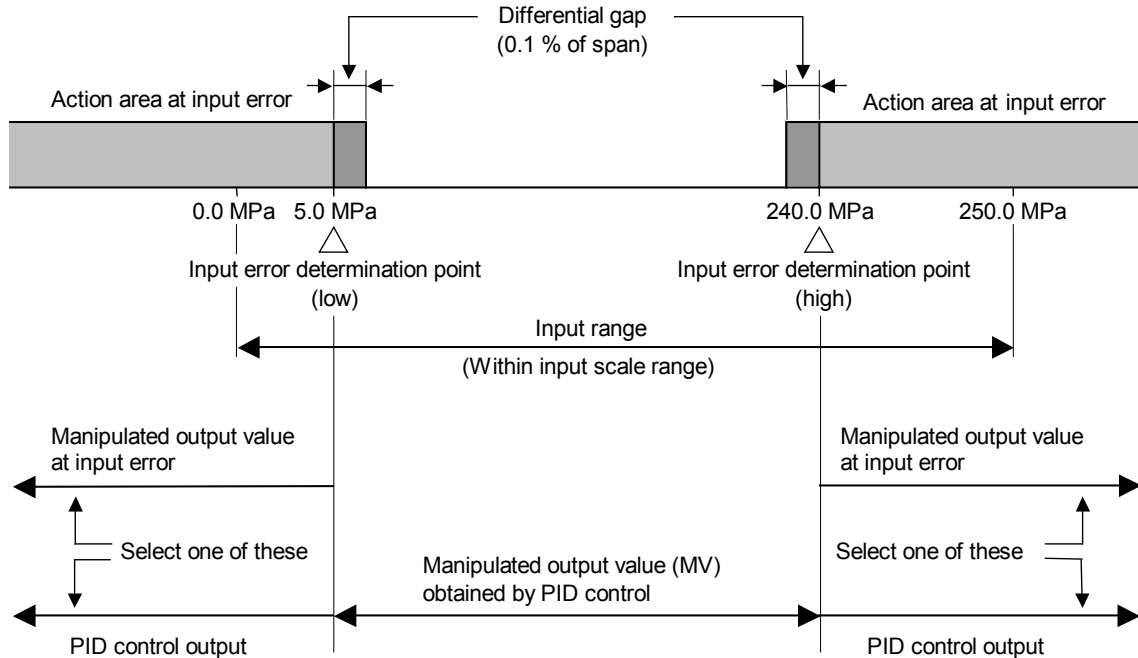

Input 1_action at input error (low)	Attribute ID	177 (0x00B1)
Input 2_action at input error (low)	Attribute ID	190 (0x00BE)

Use to select the action when the measured value reaches the Input error determination point (low).

Attribute: R/W (Read and Write)



This item becomes RO (Read only) during control RUN.

Data range: 0: Normal control
1: Manipulated output value at input error

Factory set value: Input 1_action at input error (low): 0
Input 2_action at input error (low): 0

Related parameters: Input error determination point (low) (P. 78),
Manipulated output value at input error (P. 102)

Input error determination:
Refer to the Action at input error (high).

Input 1_manipulated output value at input error	Attribute ID	178 (0x00B2)
Input 2_manipulated output value at input error	Attribute ID	191 (0x00BF)

When the measured value reaches Input error determination point and Action at input error is set to “1,” this manipulated value is output.

Attribute: R/W (Read and Write)



This item becomes RO (Read only) during control RUN.

Data range: -5.0 to +105.0 %

Factory set value: Input 1_manipulated output value at input error: -5.0
Input 2_manipulated output value at input error: -5.0

Related parameters: Input error determination point (high) (P. 77),
Input error determination point (low) (P. 78),
Action at input error (high) (P. 101),
Action at input error (low) (P. 102)

Input 1_output change rate limiter (up)	Attribute ID	179 (0x00B3)
Input 2_output change rate limiter (up)	Attribute ID	192 (0x00C0)

Use to set the Output change rate limiter (up) to limit of the variation of output is set.

Attribute: R/W (Read and Write)



This item becomes RO (Read only) during control RUN.

Data range: 0.0 to 1000.0 %/second of manipulated output
0.0: OFF (Unused)

Factory set value: Input 1_output change rate limiter (up): 0.0
Input 2_output change rate limiter (up): 0.0

Related parameters: Output change rate limiter down (P. 103), Output limiter high (P. 105),
Output limiter low (P. 105)

Output change rate limiter:
Refer to the next page.

Input 1_output change rate limiter (down)	Attribute ID	180 (0x00B4)
Input 2_output change rate limiter (down)	Attribute ID	193 (0x00C1)

Use to set the Output change rate limiter (down).

Attribute: R/W (Read and Write)



This item becomes RO (Read only) during control RUN.

Data range: 0.0 to 1000.0 %/second of manipulated output
0.0: OFF (Unused)

Factory set value: Input 1_output change rate limiter (down): 0.0
Input 2_output change rate limiter (down): 0.0

Related parameters: Output change rate limiter up (P. 103), Output limiter high (P. 105),
Output limiter low (P. 105)

Output change rate limiter:
Refer to the next page.

Continued on the next page.

Continued from the previous page.

Output change rate limiter:

The Output change rate limiter limits the variation of Manipulated output (MV) per second. This function is suitable for an application in which a sudden MV change is not acceptable.

[Example]

The output change rate limiter is effective

- The MV reaches 100 % when the power is turned on to the controller and such a sudden output change is not acceptable in the application.
- A sudden output change occurs at the SV change and it is not acceptable in the application.

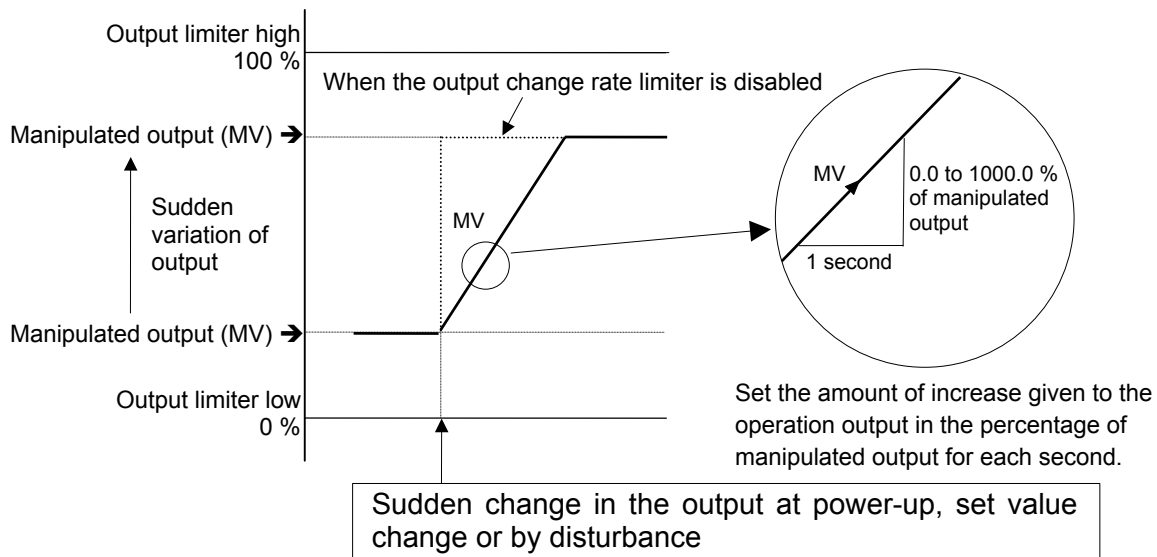

The output changes at specific rates set by Output change rate limiter (up) even under the situations where a sudden output change would occur without Output change rate limiter function. There is also independent Output change rate limiter (down).



If the Output change rate is set smaller, it will cause slow control response and affect Derivative action.



When the Output change rate limiter is used, you may not be able to obtain appropriate PID constants by Autotuning.



The Output change rate limiter is particularly effective when a sudden MV change may create uncontrollable situation cause a large current flow. Also, it is very effective current output or voltage output is used as control output.

Input 1_output limiter high	Attribute ID	181 (0x00B5)
Input 2_output limiter high	Attribute ID	194 (0x00C2)

Use to set the high limit value of manipulated output.

Attribute: R/W (Read and Write)



This item becomes RO (Read only) during control RUN.

Data range: Output limiter low to 105.0 %

Factory set value: Input 1_output limiter high: 105.0

Input 2_output limiter high: 105.0

Related parameters: Output change rate limiter (up) (P. 103),
Output change rate limiter (down) (P. 103), Output limiter low (P. 105)

Input 1_output limiter low	Attribute ID	182 (0x00B6)
Input 2_output limiter low	Attribute ID	195 (0x00C3)

Use to set the low limit value of manipulated output.

Attribute: R/W (Read and Write)



This item becomes RO (Read only) during control RUN.

Data range: -5.0 % to Output limiter high

Factory set value: Input 1_output limiter low: -5.0

Input 2_output limiter low: -5.0

Related parameters: Output change rate limiter (up) (P. 103),
Output change rate limiter (down) (P. 103), Output limiter high (P. 105)

Input 1_AT bias	Attribute ID	197 (0x00C5)
Input 2_AT bias	Attribute ID	200 (0x00C8)

Use to set a bias to move the set value only when Autotuning is activated.

Attribute: R/W (Read and Write)



This item becomes RO (Read only) during control RUN.

Data range: -Input span to +Input span

Factory set value: Input 1_AT bias: 0

Input 2_AT bias: 0

Related parameters: PID/AT transfer (P. 46)

Functional description: The AT bias is used to prevent overshoot during Autotuning in the application which does not allow overshoot even during Autotuning. RKC Autotuning method uses ON/OFF control at the set value to calculate the PID values. However, if overshoot is a concern during Autotuning, the desired AT bias should be set to lower the set point during Autotuning so that overshoot is prevented.

Example: When AT bias is set to the minus (-) side

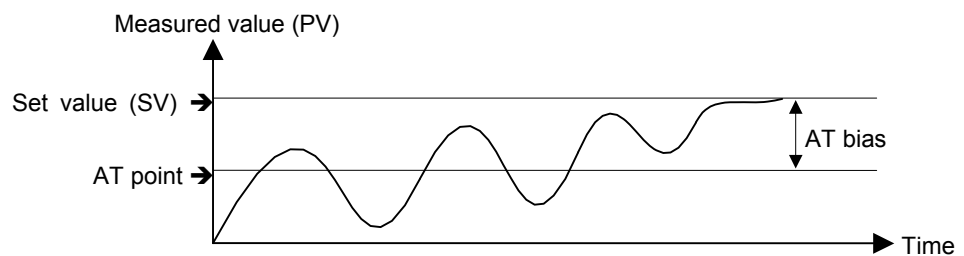

Input 1_AT cycle	Attribute ID	198 (0x00C6)
Input 2_AT cycle	Attribute ID	201 (0x00C9)

Use to select the number of ON/OFF cycles used to calculate PID values during Autotuning.

Attribute: R/W (Read and Write)



This item becomes RO (Read only) during control RUN.

Data range:

- 0: 1.5 cycles
- 1: 2.0 cycles
- 2: 2.5 cycles
- 3: 3.0 cycles

Factory set value: Input 1_AT cycle: 1
Input 2_AT cycle: 1

Related parameters: PID/AT transfer (P. 46)

Example:

When the AT cycle is set to 1.5 cycle and the Autotuning (AT) function is executed just after the power is turned on.

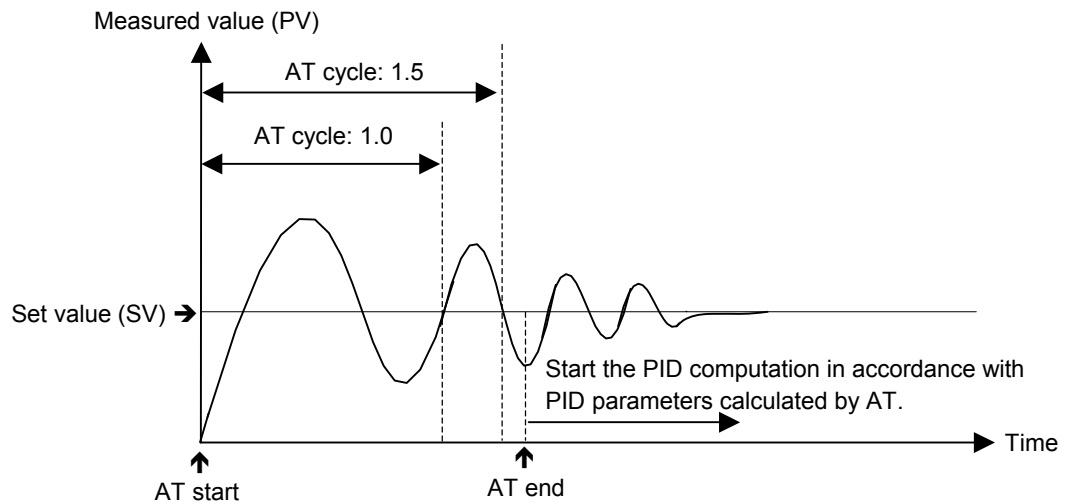

Input 1_AT differential gap time	Attribute ID	199 (0x00C7)
Input 2_AT differential gap time	Attribute ID	202 (0x00CA)

Use to set an ON/OFF action differential gap time for Autotuning. This function prevents the AT function from malfunctioning caused by noise.

Attribute: R/W (Read and Write)



This item becomes RO (Read only) during control RUN.

Data range: 0.00 to 50.00 seconds

Factory set value: Input 1_AT differential gap time: 0.10
 Input 2_AT differential gap time: 0.10

Related parameters: PID/AT transfer (P. 46)

Functional description: In order to prevent the output from chattering due to the fluctuation of a Measured value (PV) caused by noise during Autotuning, the output on or off state is held until “AT differential gap time” has passed after the output on/off state is changed to the other. Set “AT differential gap time” to “1/100 × Time required for temperature rise.”

Example:

A: AT cycle time when the AT differential gap time is set to 0.00 second

The output chatters due to the fluctuation of the Measured value (PV) caused by noise, and Autotuning function is not able to monitor appropriate cycles to calculate suitable PID values.

B: AT cycle time when the AT differential gap time is set to “Time corresponding to 0.25 cycles.”

The fluctuation of a Measured value (PV) caused by noise is ignored and as a result Autotuning function is able to monitor appropriate cycles to calculate suitable PID values.

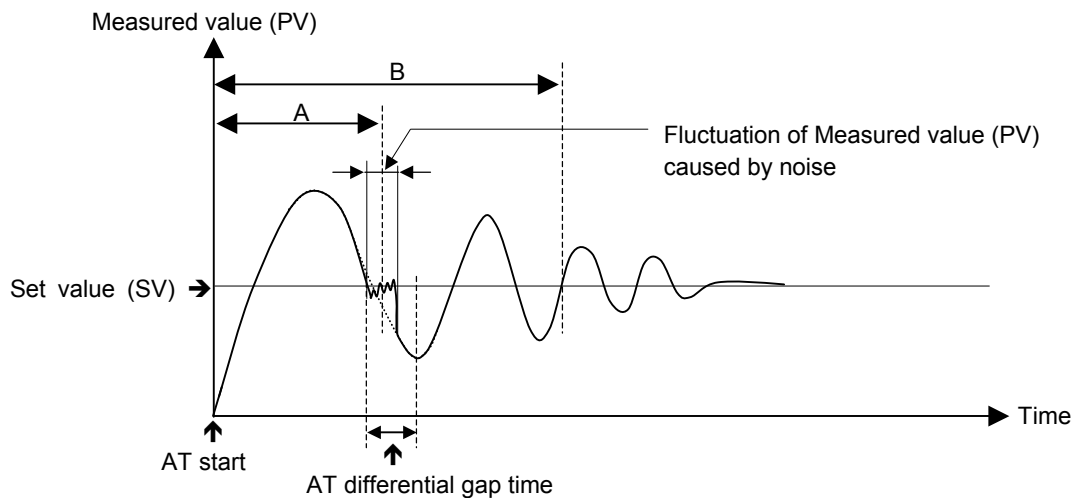

The factory set value of the AT cycle is 2 cycles.

Setting change rate limiter unit time	Attribute ID	207 (0x00CF)
---------------------------------------	--------------	--------------

Set the time unit for Setting change rate limiter (up/down).

Attribute: R/W (Read and Write)



This item becomes RO (Read only) during control RUN.

Data range: 1 to 3600 seconds

Factory set value: 60

Related parameters: Setting change rate limiter (up/down) (P. 55)

Soak time unit selection	Attribute ID	208 (0x00D0)
--------------------------	--------------	--------------

Use to select the time unit for Area soak time.

Attribute: R/W (Read and Write)



This item becomes RO (Read only) during control RUN.

Data range: 0: 0 hour 00 minutes 00 second to 9 hours 59 minutes 59 seconds
2: 0 minutes 00.00 seconds to 9 minutes 59.99 seconds

Factory set value: 2

Related parameters: Area soak time (P. 57)

Input 1_setting limiter high	Attribute ID	209 (0x00D1)
Input 2_setting limiter high	Attribute ID	211 (0x00D3)

Use to set a high limit of the set value.

Attribute: R/W (Read and Write)



This item becomes RO (Read only) during control RUN.

Data range: Setting limiter low to Input scale high

Factory set value: Input 1_setting limiter high: Input 1_input scale high
Input 2_setting limiter high: Input 2_input scale high

Related parameters: Decimal point position (P. 74), Input scale high (P. 75),
Setting limiter low (P. 110)

Setting limiter: Setting Limiter is to set the range of the Set value (SV).

Example:

The input range (input scale range) is from 0.0 to 250.0 MPa, the setting limiter high is 200.0 MPa, and the setting limiter low is 20.0 MPa.

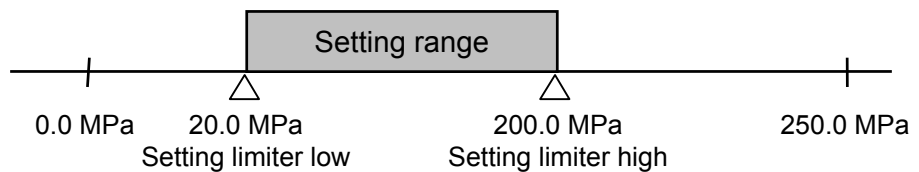

Input 1_setting limiter low	Attribute ID	210 (0x00D2)
Input 2_setting limiter low	Attribute ID	212 (0x00D4)

Use to set a low limit of the set value.

Attribute: R/W (Read and Write)



This item becomes RO (Read only) during control RUN.

Data range: Input scale low to Setting limiter high

Factory set value: Input 1_setting limiter low: Input 1_input scale low
Input 2_setting limiter low: Input 2_input scale low

Related parameters: Decimal point position (P. 74), Input scale low (P. 76),
Setting limiter high (P. 110)

Functional description: Refer to the setting limiter high.

ROM version display	Attribute ID	213 (0x00D5)
---------------------	--------------	--------------

This value is a version of the ROM loaded on the controller.

Attribute: RO (Read only)

Data range: Display the version of loading software.

Factory set value: —

Integrated operating time display	Attribute ID	214 (0x00D6)
-----------------------------------	--------------	--------------

This value is an integrated operating time of the controller.

Attribute: RO (Read only)

Data range: 0 to 99999 hours

Factory set value: —

Holding peak value ambient temperature display	Attribute ID	215 (0x00D7)
--	--------------	--------------

This value is a maximum ambient temperature on the rear terminal board of the instrument.

Attribute: RO (Read only)

Data range: -10.0 to +100.0 °C
(14.0 to 212.0 °F)

Factory set value: —

Alarm lamp lighting condition setting	Attribute ID	224 (0x00E0)
---------------------------------------	--------------	--------------

Use to set an alarm (ALM) lamp lighting conditions to Event 1 to Event 4.

Attribute: R/W (Read and Write)

 **This item becomes RO (Read only) during control RUN.**

Data range: 0 to 15 (Bit data)

Bit 0 to Bit 3 are used. (Bit 4 to Bit 31: Unused)

The alarm lamp lighting condition setting is assigned as a bit image in binary numbers.

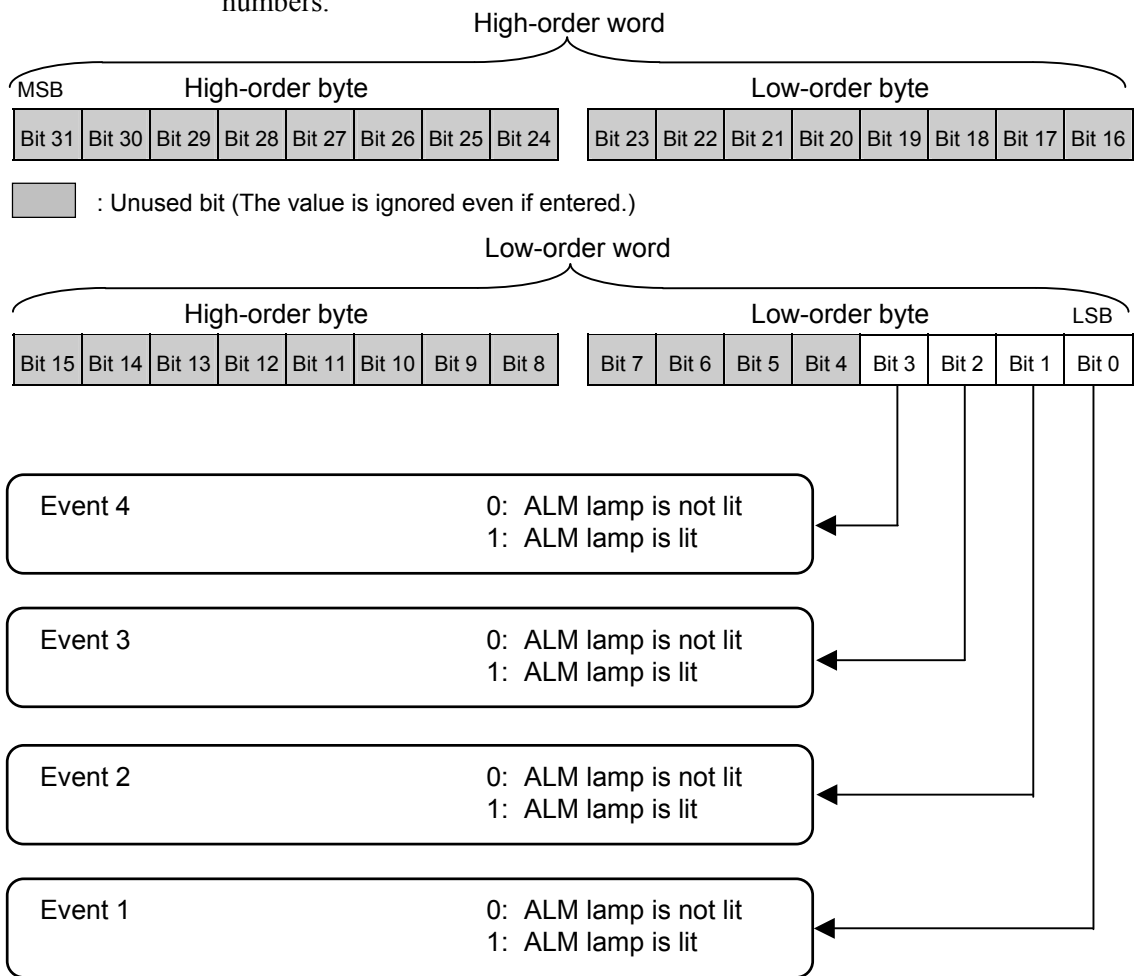

Factory set value: 15

Related parameters: Output logic selection (P. 84), Output timer setting (P. 86),
Event type selection (P. 89)

 **The alarm lamp is lit through the OR operation of Event 1 to Event 4 each of which is set to “1: ALM lamp is lit.”**

Input 1_PV1 hold function	Attribute ID	226 (0x00E2)
Input 2_PV2 hold function	Attribute ID	227 (0x00E3)

Use to select Use/Unuse of the peak hold/bottom hold function for a Measured value (PV).

Attribute: R/W (Read and Write)



This item becomes RO (Read only) during control RUN.

Data range: 0: Unused
1: Used

Factory set value: Input 1_PV1 hold function: 0
Input 2_PV2 hold function: 0

Related parameters: PV1/PV2 peak hold value monitor (P. 65),
PV1/PV2 bottom hold value monitor (P. 66),
PV1/PV2 hold reset (P. 67)

Gain setting	Attribute ID	228 (0x00E4)
--------------	--------------	--------------

Use to set the gain of the pressure sensor.

Attribute: R/W (Read and Write)



This item becomes RO (Read only) during control RUN.

Data range: 0.500 to 4.000 mV/V

Factory set value: CZ-100P, CZ-200P: 1.500 mV/V

● **CZ-100P or CZ-200P:**

Set the rated output value (mV/V) engraved on the rated nameplate attached to the pressure sensor housing.

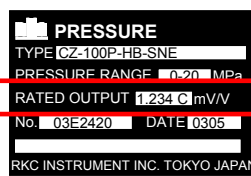

(Example of the rated nameplate)



The rated output value (mV/V) of the CZ-100P/CZ-200P is when the cable is at a length of 5 m. If the cable is extended, correct the rated output value using the following equation. Set the correction value thus calculated to “Gain setting.”

$$\text{Correction equation: } e1 = e2 (1 + K \cdot L) \quad \longrightarrow \quad e2 = \frac{e1}{1 + K \cdot L}$$

e1: Rated output in standard-cable length 5 m (mV/V is described on the nameplate of the sensor)

e2: Rated output after extension

K: Correction factor* $1.96 \times 10^{-4}/\text{m}$ [Non-explosionproof specification type],
 $1.40 \times 10^{-4}/\text{m}$ [Explosionproof specification type]

* When using $0.5 \text{ mm}^2 \times 4\text{-core}$ shielded cable (standard-cable) or equal.

L: Extended cable length (m)

● **The strain gauge type sensor other than RKC product:**

Set the rated output value (mV/V). The rated output value depends on the sensors, refer to the instruction manual for each sensor being used.

Linearize type selection	Attribute ID	229 (0x00E5)
--------------------------	--------------	--------------

Use to select the linearizing type of our pressure sensor CZ-100P/CZ-200P.

Attribute: R/W (Read and Write)

 **This item becomes RO (Read only) during control RUN.**

Data range: 0: Unused
1 to 20: Used

[Linearizing type selection table]

Set Value	Linearizing type symbol	Set Value	Linearizing type symbol	Set Value	Linearizing type symbol
0	No symbol	7	J	14	S
1	C	8	K	15	T
2	D	9	L	16	U
3	E	10	M	17	V
4	F	11	P	18	W
5	G	12	Q	19	X
6	H	13	R	20	Y

 Select the linearizing type symbol engraved on the rated nameplate attached to the CZ-100P or CZ-200P housing.

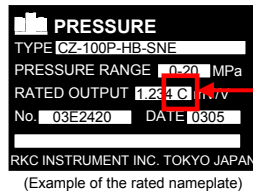

The symbol described at the end of the rated output value denotes the linearizing type. In the example at the left, "C" is the symbol of denoting the linearizing type.

 This setting does not used to the strain gauge type sensors other than RKC product. Set it to "0" fixed.

Factory set value: 0

Shunt resistance output value	Attribute ID	230 (0x00E6)
-------------------------------	--------------	--------------

When the strain gauge type sensor other than RKC product is used, it is set “What percentage of the rated output” is output when the full scale point of the Input 1_measured value (PV1) is adjusted by Auto calibration.

Attribute: R/W (Read and Write)



This item becomes RO (Read only) during control RUN.

Data range: 40.0 to 100.0 %

Factory set value: 80.0



For details of the shunt resistance output value, refer to Instruction Manual for each sensor being used.

Input 1_ PV transfer function	Attribute ID	231 (0x00E7)
Input 2_ PV transfer function	Attribute ID	232 (0x00E8)

It is selected whether or not PV with the control mode transferred to Auto control from Manual control is used as SV. It is possible to prevent a Manipulated output value (MV) from its sudden change by substituting PV for SV.

Attribute: R/W (Read and Write)



This item becomes RO (Read only) during control RUN.

Data range: 0: Unused

1: Used

Factory set value: Input 1_PV transfer function: 0

Input 2_PV transfer function: 0

Related parameters: Input 1_Auto/Manual transfer (P. 48),

Input 2_Auto/Manual transfer (P. 48)

MV scaling high	Attribute ID	233 (0x00E9)
-----------------	--------------	--------------

This value is to set the high limit value of MV scaling monitor value.

Set the motor RPM when MV1 = 100 %.

Attribute: R/W (Read and Write)



This item becomes RO (Read only) during control RUN.

Data range: -1999.9 to +9999.9

Factory set value: 100.0

Related parameters: MV scaling low (P. 117), Decimal point position of MV scaling (P. 117)

MV scaling function: The MV Scaling function is used to make scaling of Manipulated output value 1 (MV1) from 0 to 100 % between the high and low MV scaling limits as the RPM of extruder's main motor.

MV scaling high: Sets the value corresponding to the RPM of extruder's main motor at the high limit of control output.

Setting range: -1999.9 to +9999.9

MV scaling low: Sets the value corresponding to the RPM of extruder's main motor at the low limit of control output.

Setting range: -1999.9 to +9999.9

[Example] MV1 = If the motor RPM is set to 80.0 rpm when MV1 = 100.0 %

Decimal point position of MV scaling: One decimal place

MV scaling high (MV1 = 0.0 %): 0.0 rpm

MV scaling high (MV1 = 100.0 %): 80.0 rpm

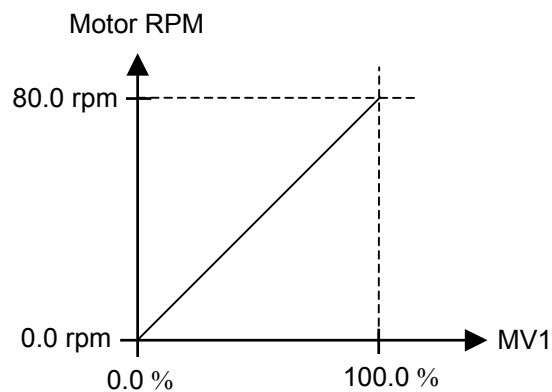

MV scaling low	Attribute ID	234 (0x00EA)
----------------	--------------	--------------

This value is to set the low limit value of MV scaling monitor value.

Set the motor RPM when MV1 = 0 %.

Attribute: R/W (Read and Write)



This item becomes RO (Read only) during control RUN.

Data range: -1999.9 to +9999.9

Factory set value: 0.0

Related parameters: MV scaling high (P. 116), Decimal point position of MV scaling (P. 117)

MV scaling function: Refer to the MV scaling high.

Decimal point position of MV scaling	Attribute ID	235 (0x00EB)
--------------------------------------	--------------	--------------

Use to select the decimal point position of the MV scaling function.

Attribute: R/W (Read and Write)



This item becomes RO (Read only) during control RUN.

Data range: 0: No decimal place 3: Three decimal places
 1: One decimal place 4: Four decimal places
 2: Two decimal places

Factory set value: 1

Related parameters: MV scaling high (P. 116), MV scaling low (P. 117)

Input 1_AT action	Attribute ID	236 (0x00EC)
Input 2_AT action	Attribute ID	237 (0x00ED)

Use to select the Autotuning (AT) function.

Attribute: R/W (Read and Write)



This item becomes RO (Read only) during control RUN.

Data range: 0: AT function (PID)
 (AT result is reflected to derivative time.)
 1: AT function (PI)
 (No AT result is reflected to derivative time.)
 2: No AT function

Factory set value: Input 1_AT action: Pressure sensor input: 2
 Input 2_AT action: TC/RTD/Voltage/Current input: 2

Input 1_Manipulated output value when transferred to Auto from Manual	Attribute ID	238 (0x00EE)
Input 2_Manipulated output value when transferred to Auto from Manual	Attribute ID	239 (0x00EF)

This is the final manipulated output value used under Manual control when the control mode is transferred to Auto control from Manual control.

Attribute: RO (Read only)

Data range: -5.0 to +105.0 %

Factory set value: —

Related parameters: Input 1_ MV transfer function (P. 121),
Input 2_ MV transfer function (P. 121)



This manipulated output value is used as a manipulated output value under Manual control when transferred to Manual control from Auto control for event input with “MV transfer function provided” selected.

Interlock function	Attribute ID	240 (0x00F0)
--------------------	--------------	--------------

Use to select the Interlock function to output 1 (OUT1) to output 5 (OUT5).

Attribute: R/W (Read and Write)

 **This item becomes RO (Read only) during control RUN.**

Data range: 0 to 31 (Bit data)

Bit 0 to Bit 4 are used. (Bit 5 to Bit 31: Unused)

The Interlock function selection is assigned as a bit image in binary numbers.

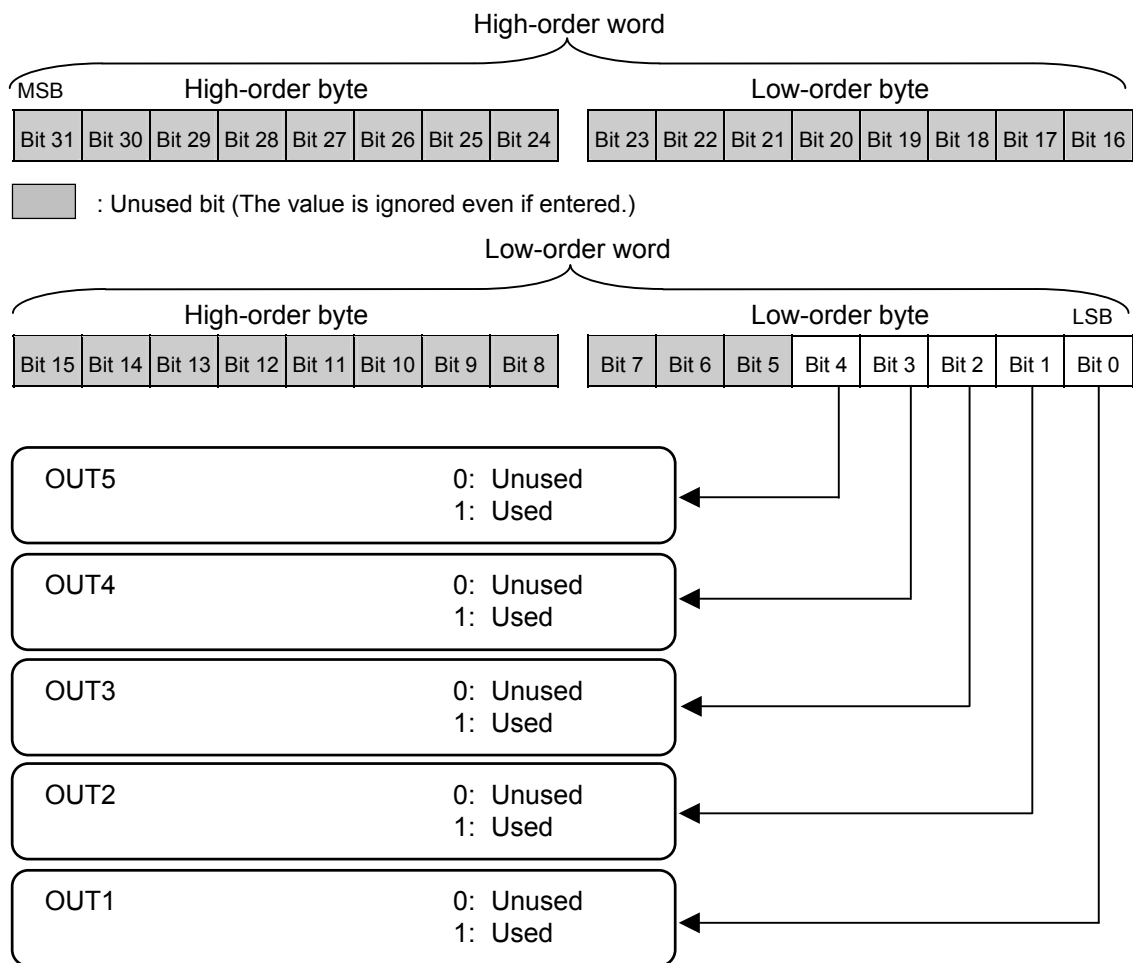

Factory set value: 0

Related parameters: Interlock release (P. 67)

Continued on the next page.

Continued from the previous page.

Interlock function: The Interlock action holds the event state even if the measured value is out of the event zone after it enters the event zone once. This interlock is released through key operation, event input (optional), or communication (optional).

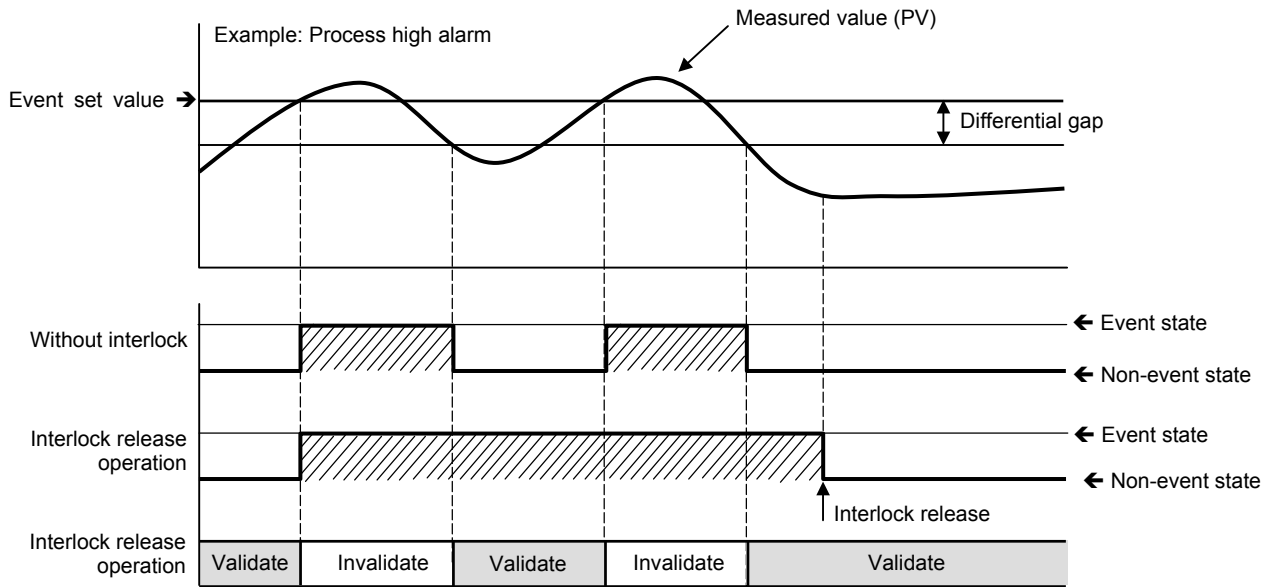

The Interlock function is released for any of the following.

- When the power is turn on. (However, the interlock becomes ON when set to the event state simultaneously with the control started.)
- When the control is stopped.



Burnout results in the event state and also activating the Interlock function.

Input 1_ MV transfer function	Attribute ID	241 (0x00F1)
Input 2_ MV transfer function	Attribute ID	242 (0x00F2)

The final Manipulated output value (MV) used under Manual control with the control mode transferred to Auto control from Manual control is stored to the Manipulated output value (MV) when transferred to Auto control from Manual control. It is selected whether or not this Manipulated output value (MV) is used only as a Manipulated output value (MV) under Manual control when transferred to Manual control from Auto control for event input (DI).

Attribute: R/W (Read and Write)



This item becomes RO (Read only) during control RUN.

Data range: 0: Unused
1: Used

Factory set value: Input 1_ MV transfer function: 0
Input 2_ MV transfer function: 0

Related parameters: Input 1_ Manipulated output value when transferred to Auto from Manual (P. 118),
Input 2_ Manipulated output value when transferred to Auto from Manual (P. 118)



This function does not act as an original function when transferred to Manual control from Auto control through transfer operation by the direct key or on the operation mode screen.

7. USAGE EXAMPLE

In this Chapter, an example of using DeviceNet communication when using a PLC as a master.

7.1 Handling Procedures

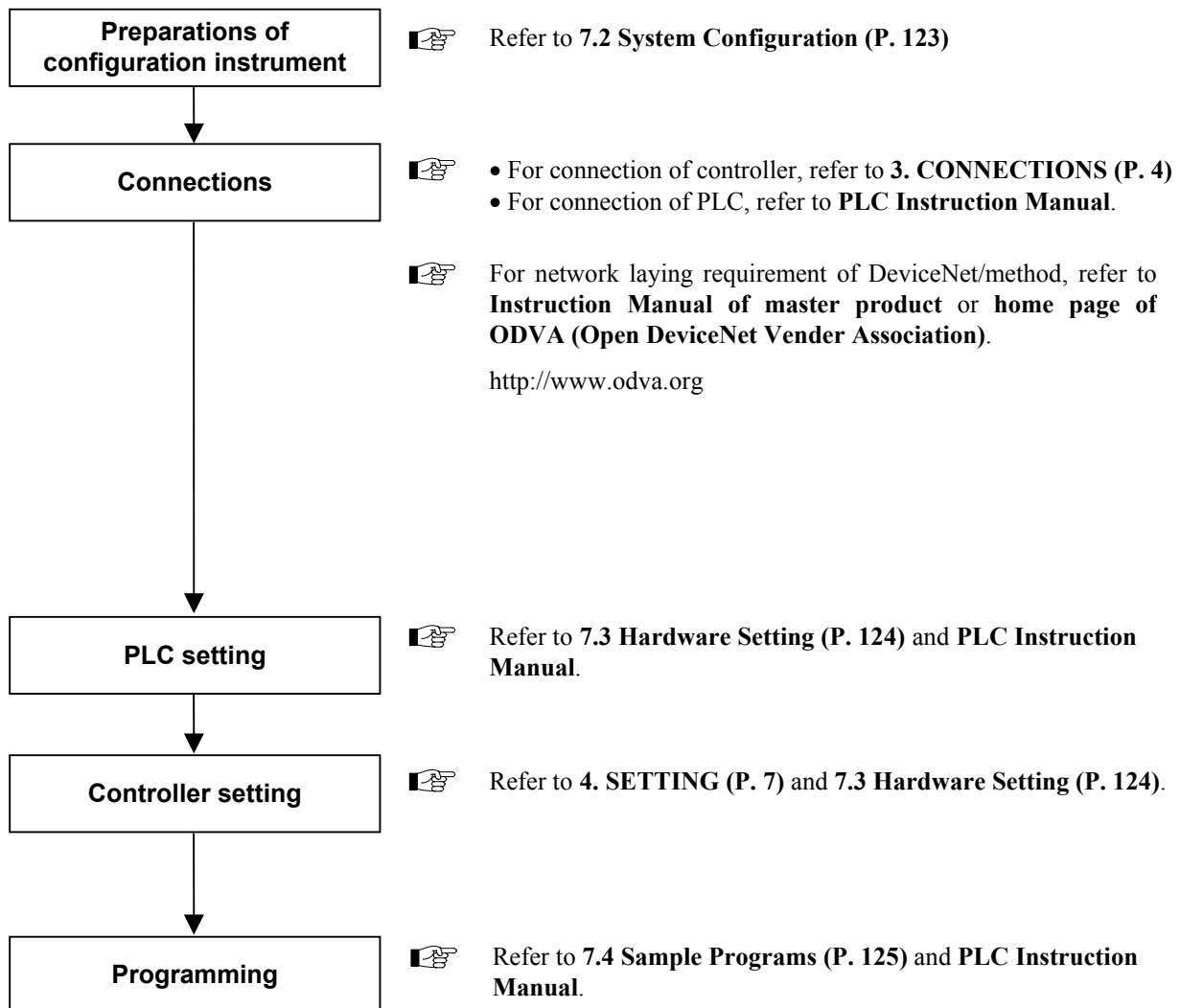

7.2 System Configuration

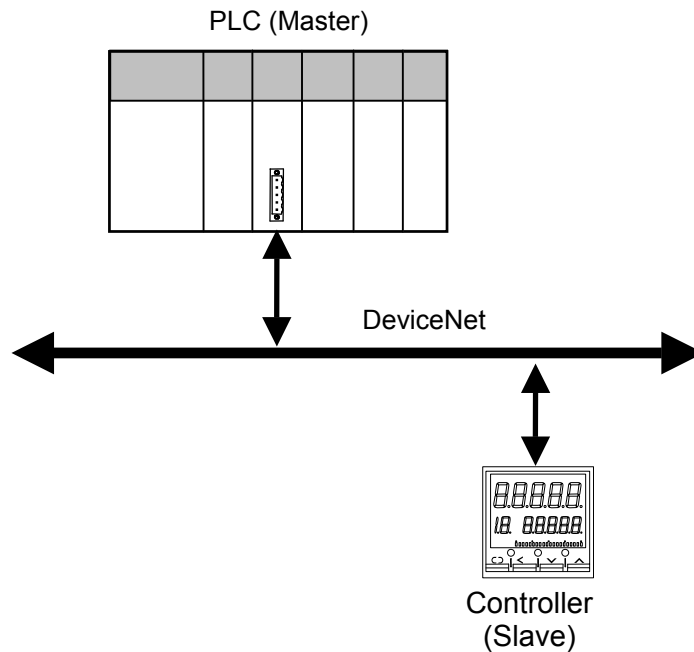

Example of system configurations

■ Use instruments

- **Controller corresponding to DeviceNet communication**

HA430 or HA930

- **PLC**

- SYSMAC CS1 (OMRON product)

CPU unit: CS1G-CPU44, DeviceNet master unit: C200HW-DRW21-V1

or

- Control Logixs 5550 [Rockwell Inc. (Allen-Bradley)]

CPU module: 1756-L1, LINK module (DeviceNet): 1756-DNB

7.3 Hardware Setting

Set each hardware's as the following.

■ PLC setting

Set PLC in requirement of the following.

[DeviceNet communication requirement]

- Node address: 0
- DeviceNet communication speed: 125 kbps
- Unit Number: 0

 For setting method, refer to Instruction Manual for PLC.

■ Controller setting

Set controller in requirement of the following.

[DeviceNet communication requirement]

- Node address: 1
- DeviceNet communication speed: 125 kbps

 For setting method, refer to **4.1 DeviceNet Setting (P. 7)**.

7.4 Sample Programs

7.4.1 Polling I/O communication (When the SYSMAC CS1)



Polling I/O communication is called “Remote I/O communication” in OMRON PLC related instruction manuals.

■ Communication requirement

The status, Input 1_set value (SV1) ID and Input 1_set value (SV1) are sent from the PLC. Then Input 1_measured value (PV1) monitor, Input 1_manipulated output value (MV1) monitor, Input 1_set value (SV1) monitor, Input 2_measured value (PV2) monitor, Input 2_manipulated output value (MV2) monitor, Input 2_set value (SV2) monitor, Input 1_set value (SV1) and Updated status are read from the controller.

● Data to send from a PLC

- Status (0x80) and Input 1_set value (SV1) ID (0x0028)
 - Low-order byte = 28H
 - High-order byte = 80H
- Input 1_set value (SV1) = 10.0
 - Low-order word = 64H
 - High-order word = 00H

● Storage location of read data from the controller

- Input 1_measured value (PV1) monitor: D00001, D00002
- Input 1_manipulated output value (MV1) monitor: D00003, D00004
- Input 1_set value (SV1) monitor: D00005, D00006
- Input 2_measured value (PV2) monitor: D00007, D00008
- Input 2_manipulated output value (MV2) monitor: D00009, D00010
- Input 2_set value (SV2) monitor: D00011, D00012
- Input 1_set value (SV1): D00013, D00014
- Updated status: D00015

● **Memory allocation**

Default allocations (without Configuration)

- SYSMAC CS1 I/O allocation
 - Output area: IR0050 to IR0099
 - Input area: IR0350 to IR0399
- Controller (Node address 1) I/O allocation
 - Output area: IR0051 to IR0053
 - Input area: IR0351 to IR036E

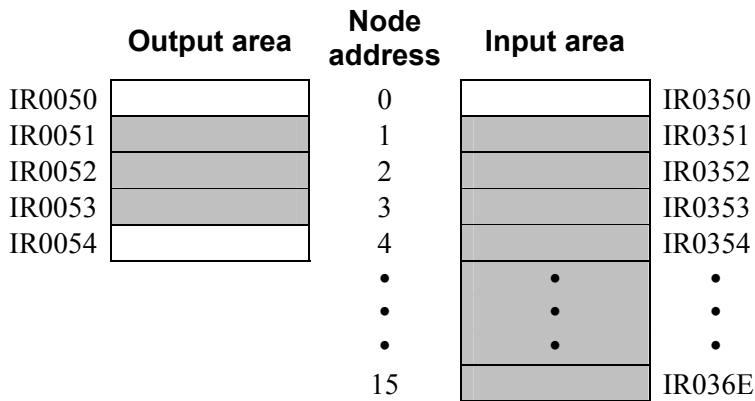

 : Controller allocation area

[Controller I/O allocation]

Can confirm a Controller I/O allocation area with **APPENDIX A. Device Profiles/Connection Object (0x05)/ Object instance 2/Attribute 7: Produced connection size and Attribute 8: Consumed connection size.**

- Produced connection size: This is the amount of memory (usually in bytes) allocated as input.
- Consumed connection size: This is the amount of memory (usually in bytes) allocated as output.



When the node address of the controller is *I*, the node addresses (1 to 15) are occupied in the controller.

■ Sample program

● Program action

- I. Read Input 1_measured value (PV1) monitor, Input 1_manipulated output value (MV1) monitor, Input 1_set value (SV1) monitor, Input 2_measured value (PV2) monitor, Input 2_manipulated output value (MV2) monitor, Input 2_set value (SV2) monitor, Input 1_set value (SV1) and Updated status. Then write Input 1_set value (SV1).
 - When the relay No. 000110 is ON:
 - “Status (0x80)” and “Input 1_set value (SV1) ID (0x0028)” are set to IR0051.
 - “Input 1_set value (SV1) (Low-order word)” is set to IR0052.
 - “Input 1_set value (SV1) (High-order word)” is set to IR0053.
 - “Input 1_measured value (PV1) monitor” is written in IR0351.
 - “Input 1_measured value (PV1) monitor” of IR0351 is stored to D00001 when IR000112 is ON.

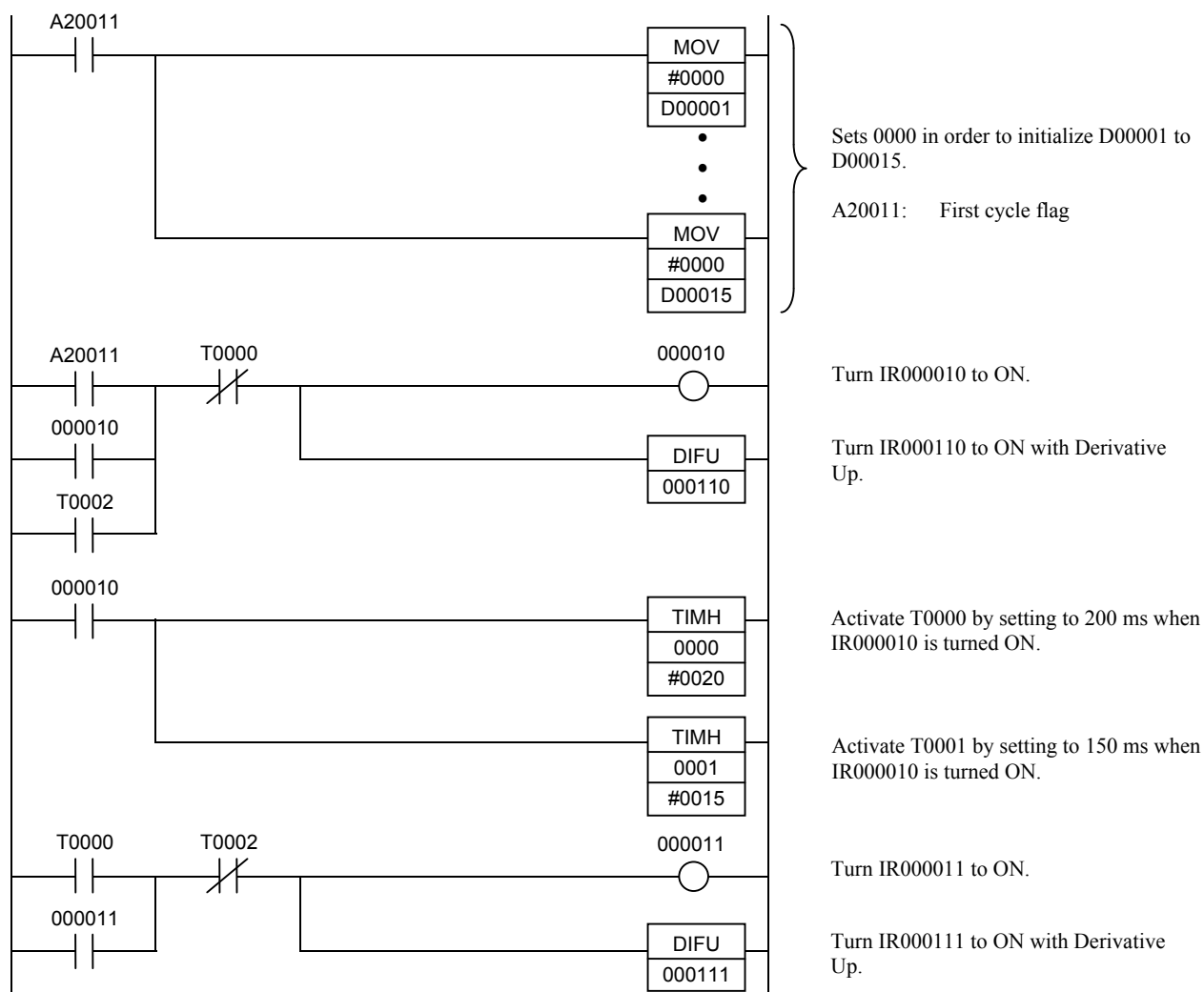

Continued on the next page.

Continued from the previous page.

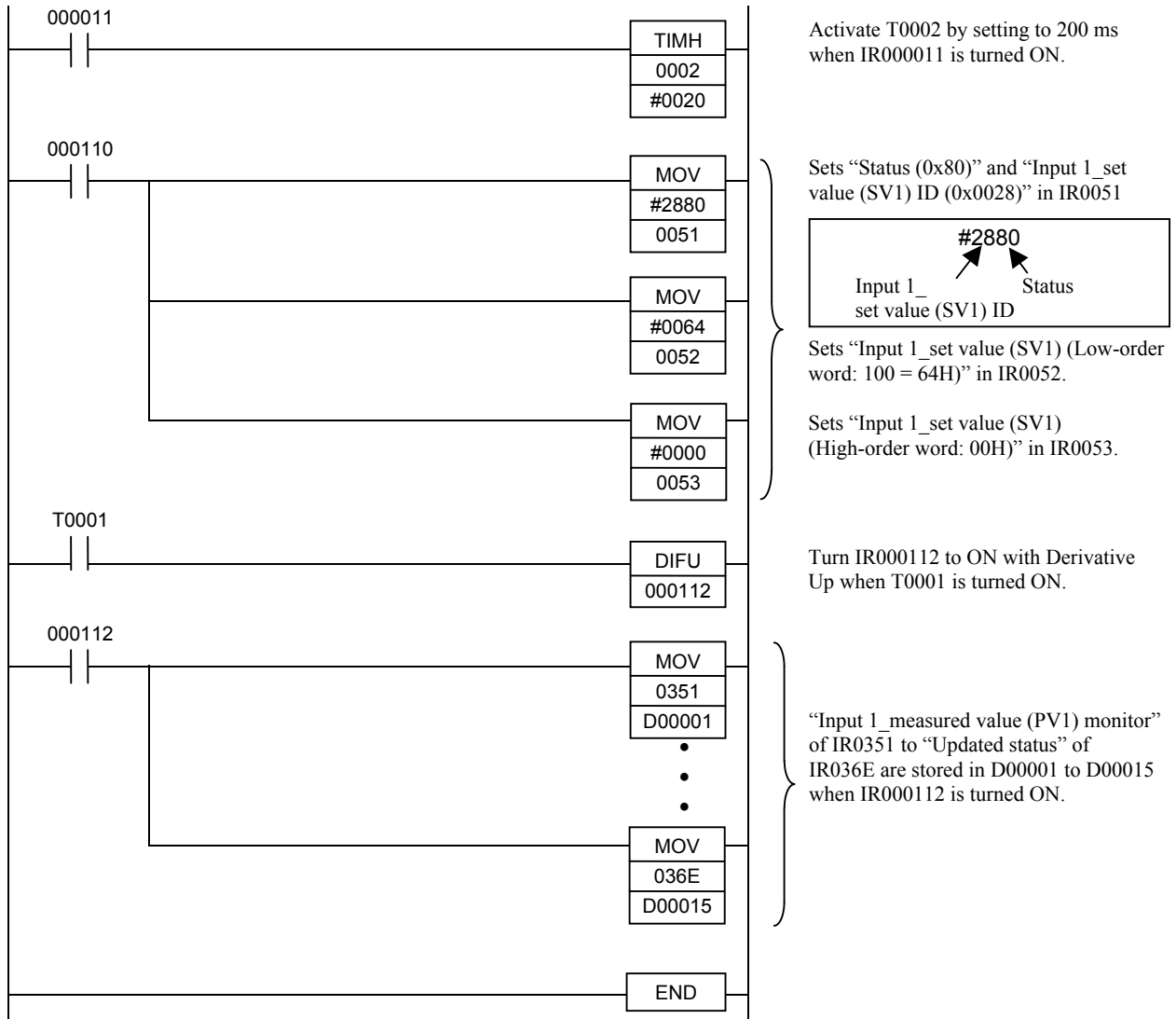

7.4.2 Polling I/O communication (When the Control Logix 5550)

■ Communication requirement

The status, Input 1_set value (SV1) ID and Input 1_set value (SV1) are sent from the PLC. Then Input 1_measured value (PV1) monitor, Input 1_manipulated output value (MV1) monitor, Input 1_set value (SV1) monitor, Input 2_measured value (PV2) monitor, Input 2_manipulated output value (MV2) monitor, Input 2_set value (SV2) monitor, Input 1_set value (SV1) and Updated status are read from the controller.

● Data to send from a PLC

- Status (0x80) and Input 1_set value (SV1) ID (0x0028)
 - Low-order byte = 28H
 - High-order byte = 80H
- Input 1_set value (SV1) = 10.0
 - Low-order word = 64H
 - High-order word = 00H

● Storage location of read data from the controller

- Input 1_measured value (PV1) monitor
- Input 1_manipulated output value (MV1) monitor
- Input 1_set value (SV1) monitor
- Input 2_measured value (PV2) monitor
- Input 2_manipulated output value (MV2) monitor
- Input 2_set value (SV2) monitor
- Input 1_set value (SV1)
- Updated status



In case of the temperature controller, set value does polling as monitor data.

● Program action

As action of sequence program, there are monitor mode and setting mode.
Execute the mode transfer with display unit connected to PLC.

<Monitor mode>

In case of monitor mode, set value does not send from PLC when set Attribute ID in "0."
Only read of the measured value from the controller.

- Storage location of read data (Variable)
 - Input 1_measured value (PV1) monitor: N20 [1 to 4]
 - Input 1_manipulated output value (MV1) monitor: N20 [11 to 14]
 - Input 1_set value (SV1) monitor: N20 [21 to 24]
 - Input 2_measured value (PV2) monitor: N20 [31 to 34]
 - Input 2_manipulated output value (MV2) monitor: N20 [41 to 44]
 - Input 2_set value (SV2) monitor: N20 [51 to 54]
 - Input 1_set value (SV1): N20 [61 to 64]
 - Updated status: N20 [71 to 72]

Continued on the next page.

Continued from the previous page.

<Setting mode>

Send set value of the PLC internal register set by display unit.

- Storage location of write data (Variable)
 - Status: N24 [1]
 - Input 1_set value (SV1) ID: N24 [2]
 - Input 1_set value (SV1): N24 [11 to 14]

● **Memory allocation**

Do the memory allocations of PLC as the following.

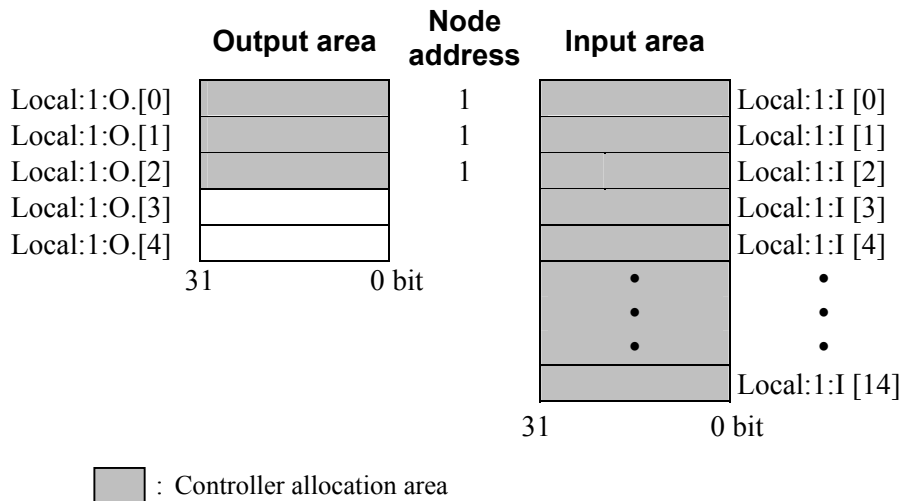

■ **Sample program**

● **Program area**

- S = Special relay
- T4 = Timer
- N20 = Internal register (Register for storage of read data)
- N23 = Internal register (Register for work)
- N24 = Internal register (Register for storage of writ data)
- DevWr = Internal register (Register for send data)
- B10 = Internal relay
- Local:1:O = OUT area (Area for DeviceNet polling I/O)
- Local:1:I = IN area (Area for DeviceNet polling I/O)

Continued on the next page.

Continued from the previous page.

● Program action

1. When read of Input 1_measured value (PV1) monitor

- With monitor mode (MODE[0]=OFF) in case of internal relay (B10[0]) ON

Sets "Status (0x00)" and "Attribute ID: 00" to "Local:1:O.Data[0]."

Sets "0" to "Local:1:O.Data[1]."

Sets "0" to "Local:1:O.Data[2]."

The data from "Input 1_measured value (PV1) monitor" to "Updated status" are written in at I/O area.

- Sets "Input 1_measured value (PV1) monitor (Low-order word)" to "Local:1:I.Data[0]."
- Sets "Input 1_measured value (PV1) monitor (High-order word)" to "Local:1:I.Data[1]."
- Sets "Input 1_manipulated output value (MV1) monitor (Low-order word)" to "Local:1:I.Data[2]."
- Sets "Input 1_manipulated output value (MV1) monitor (High-order word)" to "Local:1:I.Data[3]."
- Sets "Input 1_set value (SV1) monitor (Low-order word)" to "Local:1:I.Data[4]."
- Sets "Input 1_set value (SV1) monitor (High-order word)" to "Local:1:I.Data[5]."
- Sets "Input 2_measured value (PV2) monitor (Low-order word)" to "Local:1:I.Data[6]."
- Sets "Input 2_measured value (PV2) monitor (High-order word)" to "Local:1:I.Data[7]."
- Sets "Input 2_manipulated output value (MV2) monitor (Low-order word)" to "Local:1:I.Data[8]."
- Sets "Input 2_manipulated output value (MV2) monitor (High-order word)" to "Local:1:I.Data[9]."
- Sets "Input 2_set value (SV2) monitor (Low-order word)" to "Local:1:I.Data[10]."
- Sets "Input 2_set value (SV2) monitor (High-order word)" to "Local:1:I.Data[11]."
- Sets "Input 1_set value (SV1) (Low-order word)" to "Local:1:I.Data[12]."
- Sets "Input 1_set value (SV1) (High-order word)" to "Local:1:I.Data[13]."
- Sets "Updated status" to "Local:1:I.Data[14]."

- With time-up of "T4[0]," saved data of "Local:1:I.Data [0 to 14]" in each storage areas.

2. When write in Input 1_set value (SV1)

With setting mode (MODE[0]=ON) in case of internal relay (B10[0]) ON

Sets "Status (0x80)" and "Input 1_set value (SV1) ID (0x0028)" to "Local:1:O.Data[0]."

Local:1:O.Data[0] = 2880H

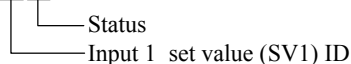

- Sets "Input 1_set value (SV1) (Low-order word)" to "Local:1:O.Data[1]."
- Sets "Input 1_set value (SV1) (High-order word)" to "Local:1:O.Data[2]."

- The flow chart of sample program

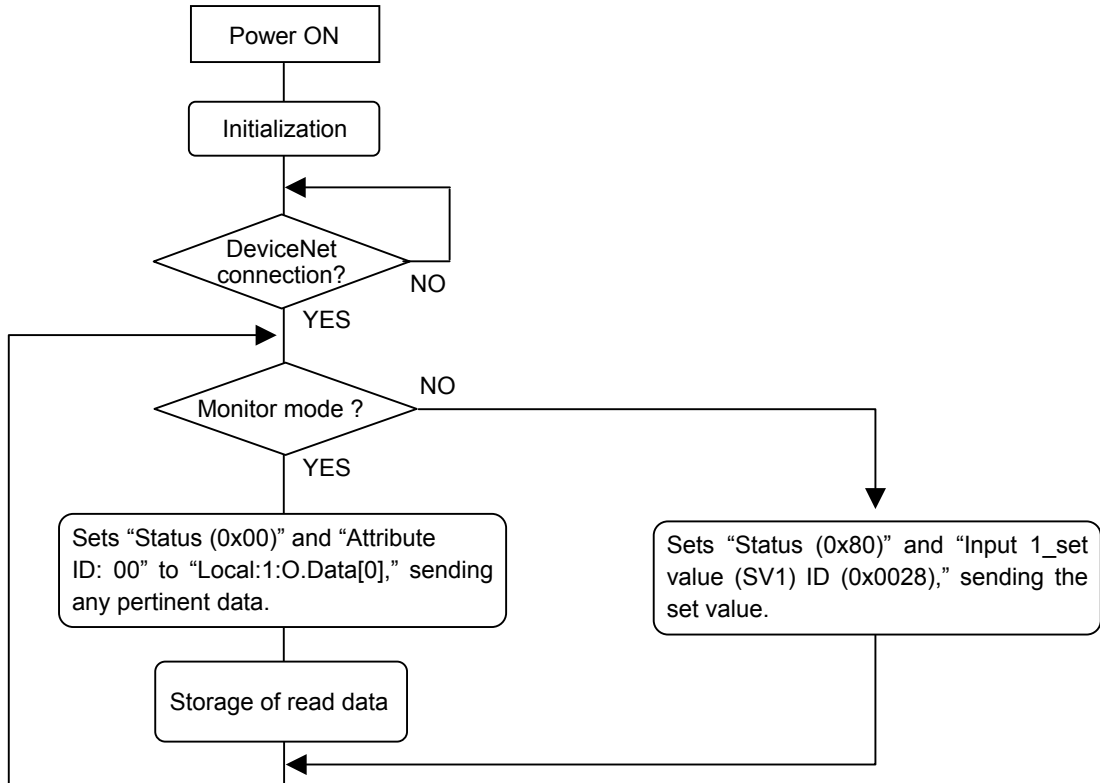

7.4.3 Explicit message communication



In order to conduct Explicit message communication using the OMRON SYSMAC CS1 PLC, the FINS command for FINS communication (communication protocol developed by OMRON) is used.

■ Communication requirement

The vendor code is read from the Controller (slave). (RKC vendor code: 394 = 018AH)

- Using the “Explicit message send” command (2801) of FINS command.
- The “IOWR instruction” is used to send FINS commands.
IOWR instruction is executed when “Message Communications Enabled Flag” is turned ON.
- Write location of request data from the PLC (master): On and after D01000
- Storage location of response data from the Controller (slave): On and after D02000
- The completion code is stored in D00006 when execution of IOWR has been completed and then the command is executed again.
- When an Explicit message is sent by the SYSMAC CS1, the send location of the FINS command is assigned to the DeviceNet master unit of its own node instead of the actual send location (Controller).
The Controller node address is specified within Explicit message send command data.

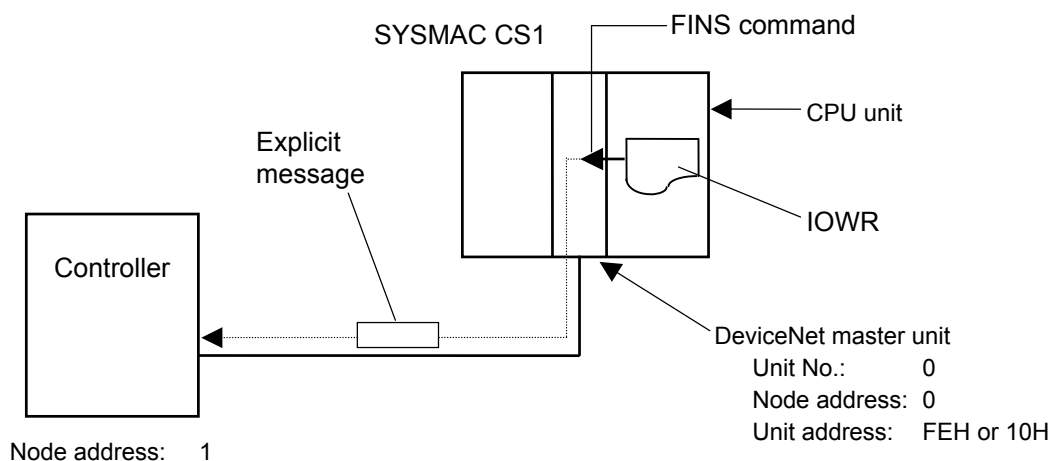

Explicit message flow

● Description of IOWR

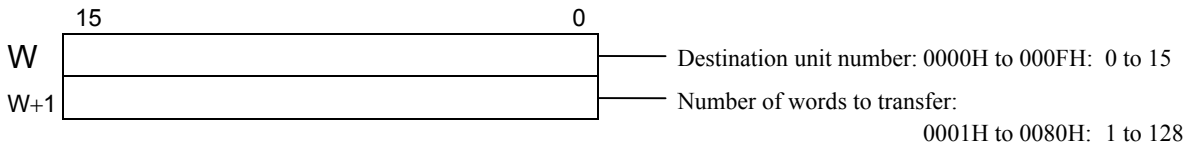
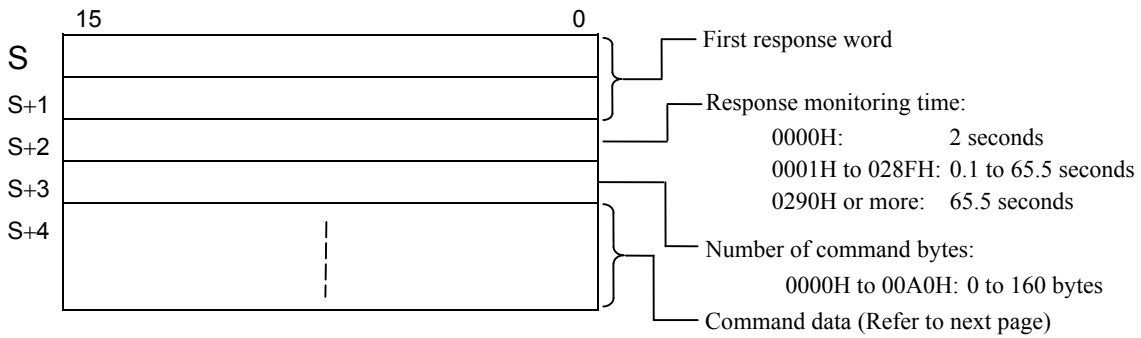
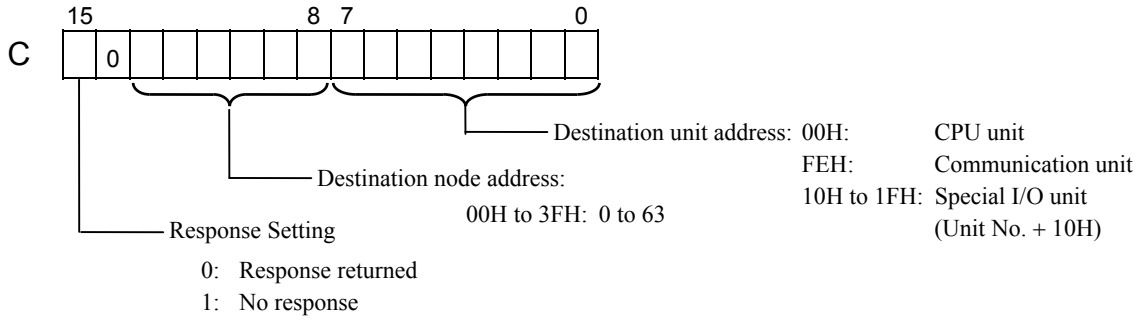
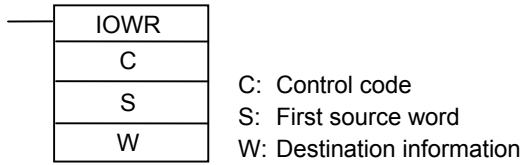

[For sample program]

C D00100 00FEH Response returned (0), Destination node address (00H),
Destination unit address: FEH (or 10H)

S D01000 +0 8207H * } First response word (D02000)
+1 D000H * }
+2 028FH Response monitoring time (65.5 seconds)
+3 0009H Number of command bytes (9 bytes)
+4 2801H Explicit message sending command
+5 010EH Slave node address (1), Service code (0EH)
+6 0001H Object class ID (0001H)
+7 0001H Instance ID (0001H)
+8 0100H Attribute ID (01H)

W +0 #0000 Destination unit number
+1 #0009 Number of words to transfer

* Divide "8207D000" into 2, and have entered
82: Memory area code (Data Memory: D)
07D0: 2000
00: Specified "00"

● Command data format

Command data format at communicating by an Explicit message with SYSMAC CS1 is shown with the following.

[Request data format from the PLC (master)]

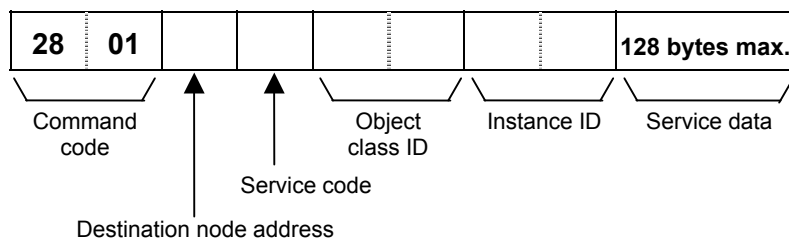

[Response data format]

● Normal response

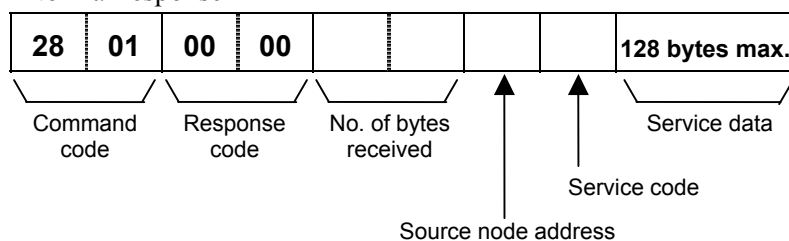

● Error response

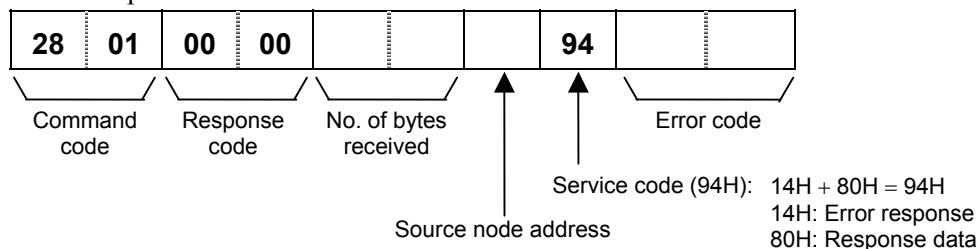

● Cannot be sent/Timeout

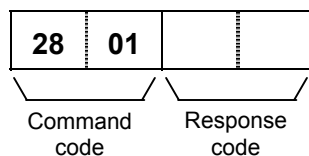

As this response (Cannot be sent/Timeout) is an error response sent to the CPU unit from the DeviceNet master unit of the SYSMAC CS1, this is not an error in DeviceNet communication.

■ Sample program

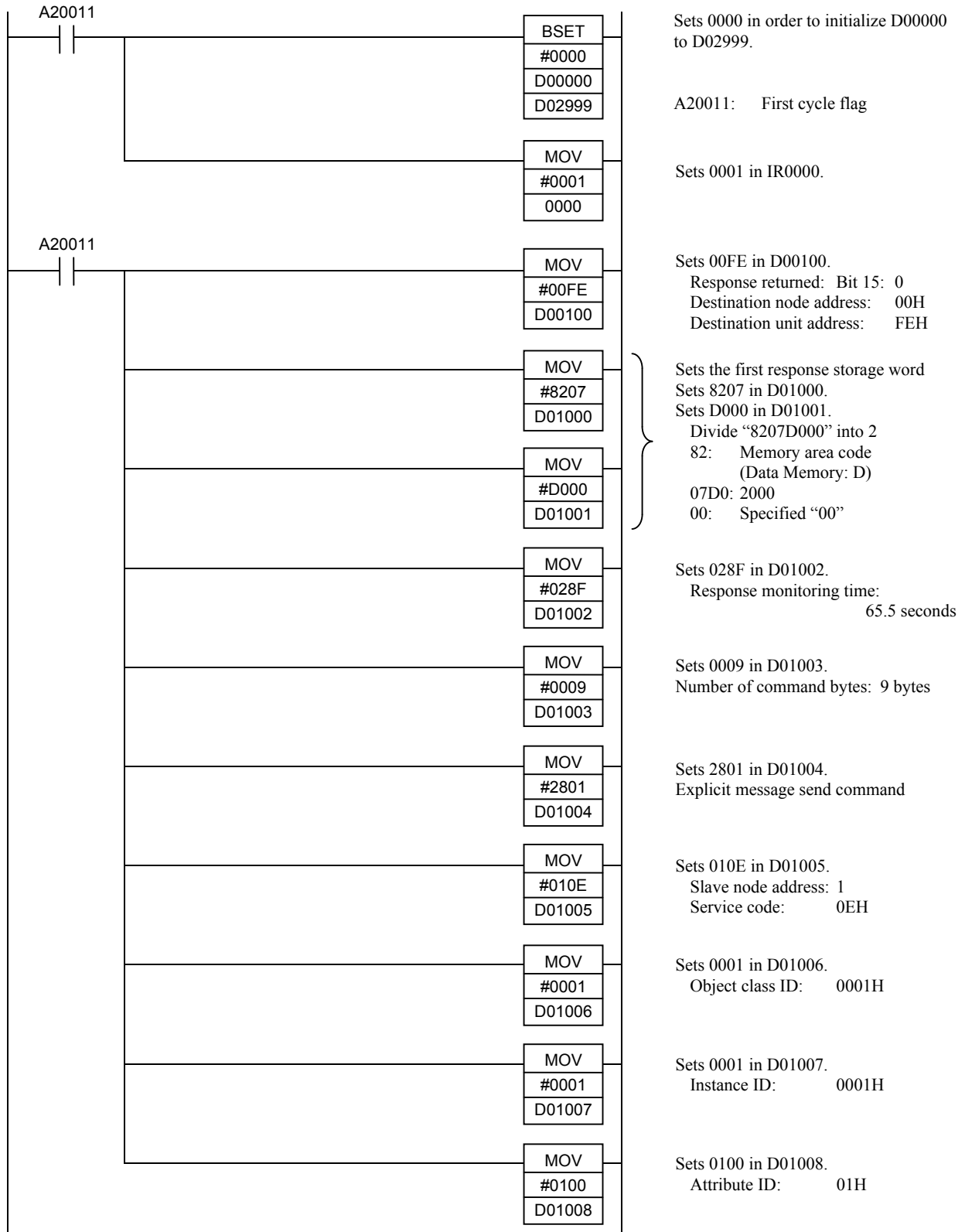

Continued on the next page.

Continued from the previous page.

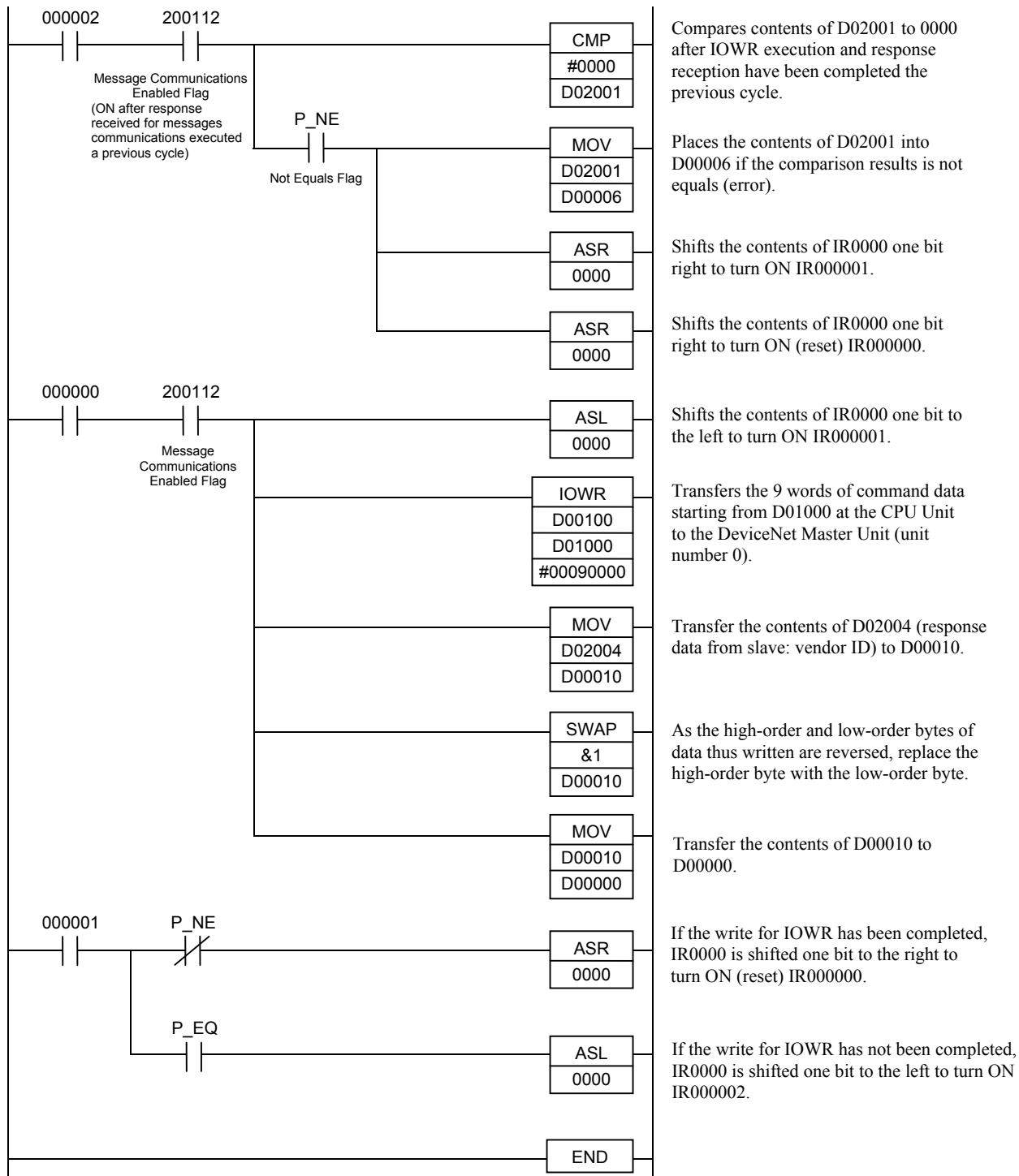

8. TROUBLESHOOTING

This section explains probable causes and solutions if any abnormality occurs in the instrument. For any inquiries or to confirm the specifications of the product, please contact RKC sales office or the agent.

If it is necessary to replace a device, always strictly observe the warnings below.

WARNING

- To prevent electric shock or instrument failure, always turn off the system power before replacing the instrument.
- To prevent electric shock or instrument failure, always turn off the power before mounting or removing the instrument.
- To prevent electric shock or instrument failure, do not turn on the power until all wiring is completed. Make sure that the wiring is correct before applying power to the instrument.
- To prevent electric shock or instrument failure, do not touch the inside of the instrument.
- All wiring must be performed by authorized personnel with electrical experience in this type of work.

CAUTION

All wiring must be completed before power is turned on to prevent electric shock, instrument failure, or incorrect action. The power must be turned off before repairing work for input break and output failure including replacement of sensor, contactor or SSR, and all wiring must be completed before power is turned on again.

Problem	Possible cause	Solution
No response (DeviceNet)	Wrong connection, no connection or disconnection of the DeviceNet communication cable	Confirm the connection method or condition and connect correctly
	Breakage, wrong wiring, or imperfect contact of the DeviceNet communication cable	Confirm the wiring or connector and repair or replace the wrong one
	Communication speed setting of master (PLC) and the slave (HA430/930) is mismatch	Confirm the communication speed setting and set that correctly
	Wrong node address setting	Confirm the address setting and set that correctly

APPENDIX

A. Device Profiles

A device profile is the specification that defined each necessary parameter with DeviceNet. Use it after understanding contents of a device profile of the controller fully when connected to a master.

A.1 Basic data

■ General device data

Conforms to DeviceNet specification	Volume I -Release 2.0 Volume II -Release 2.0
Vendor name	RKC INSTRUMENT INC. (Vendor ID = 394)
Device profile name	Generic Device
Product catalog number	Instruction manual number: IMR01N15-E□ (English) IMR01N15-J□ (Japanese)
Product revision	1.0

■ Physical conformance data

Network power consumption	50 mA @ DC 11 V 40 mA @ DC 24 V
Connector type	Unsealed hard wired
Insulated physical layer	Provided
LEDs supported	None
MAC ID setting	Soft setting (device address 2 setting)
Default MAC ID	0
Communication speed setting	Soft setting (Communication speed 2 setting)
Communication speed supported	125 kbps, 250 kbps, 500 kbps

■ Communication data

Predefined master/slave connection set	Group 2 Only server
Dynamic connection supported (UCMM)	None
Fragmented Explicit Messaging	None

A.2 Object mounting

■ Identity Object (0x01: 01Hex)

● Object class

Attributes	Not supported
Services	Not supported

● Object instance

	ID	Description	Get	Set	Type	Value	
Attributes	1	Vendor	Yes	No	UINT	394	
	2	Product type	Yes	No	UINT	0	
	3	Product code	Yes	No	UINT	2	
	4	Revision	Yes	No			
			Major revision			USINT	2
			Minor revision			USINT	1
	5	Status (bits supported)	Yes	No	WORD	Note 1	
6	Serial number	Yes	No	UDINT	Note 2		
7	Product name	Yes	No				
		Length			USINT	2	
		Name			STRING	HA	

	DeviceNet service	Parameter option
Services	0x05 Reset	0
	0x0E Get_Attribute_Single	None

Note 1 A bit layout of “Status”

Bit 0: Owned

Bit 1 to 7 and Bit 8 to 15: Unused

Note 2 A unique number for each controller

■ Message Router Object (0x02: 02Hex)**● Object class**

Attributes	Not supported
Services	Not supported

● Object instance

Attributes	Not supported
Services	Not supported

■ DeviceNet Object (0x03: 03Hex)

● Object class

	ID	Description	Get	Set	Type	Value
Attributes	1	Revision	Yes	No	UINT	2
DeviceNet service			Parameter option			
Services	0x0E	Get_Attribute_Single	None			

● Object instance

	ID	Description	Get	Set	Type	Value
Attributes	1	MAC ID	Yes	No	USINT	0 to 63
	2	Baud rate	Yes	No	USINT	0 to 2
	3	BOI	Yes	No	BOOL	0
	4	Bus-off counter	Yes	Yes	USINT	
	5	Allocation information	Yes	No		
		Allocation choice byte			BYTE	
		Master's MAC ID			USINT	
	6	MAC ID switch changed	Yes	No	BOOL	0, 1
	7	Baud rate switch changed	Yes	No	BOOL	0, 1
8	MAC ID switch value	Yes	No	USINT	0 to 63	
9	Baud rate switch value	Yes	No	USINT	0 to 2	
DeviceNet service			Parameter option			
Services	0x0E	Get_Attribute_Single	None			
	0x10	Set_Attribute_Single	None			
	0x4B	Allocate_Master/Slave_ Connection_Set	None			
	0x4C	Release_Group_2_ Identifire_Set	None			

■ Assembly Object (0x04: 04Hex)

● Object class

	ID	Description	Get	Set	Type	Value
Attributes	1	Revision	Yes	No	UINT	2

	DeviceNet service	Parameter option
Services	0x0E Get_Attribute_Single	None

● Object instance 1

	ID	Description	Get	Set	Type	Value
Attributes	3	Data (Input 1_measured value (PV1) monitor)	Yes	No	DINT	

	DeviceNet service	Parameter option
Services	0x0E Get_Attribute_Single	None
	0x10 Set_Attribute_Single	None

● Object instance 2

	ID	Description	Get	Set	Type	Value
Attributes	3	Data ¹	Yes	No	DINT	
		Status (bits supported)	No	Yes	BYTE	Note 1
		ID number	No	Yes	BYTE	Note 2
		Set value	No	Yes	DINT	Note 3

	DeviceNet service	Parameter option
Services	0x10 Set_Attribute_Single	None
	0x10 Set_Attribute_Single	None

¹ Value indicated by ID specified by set.

Note 1 During data read: 00H
During data written: 80H

Note 2 Attribute ID in the communication items list

Note 3 During data read: Pertinent data
During data written: Set value corresponding to communication item indicated by ID number.

■ Connection Object (0x05: 05Hex)

● Object class

Attributes	Not supported
Services	Not supported
Number of maximum possible active connection	1

● Object instance 1

Section	Information	Number of maximum instance
Instance type	Explicit Message	1
Production trigger	Cyclic	
Transport type	Server	
Transport class	3	

ID	Description	Get	Set	Type	Value
Attributes	1 State	Yes	No	USINT	
	2 Instance type	Yes	No	USINT	0x00
	3 Transport class trigger	Yes	No	BYTE	0x83
	4 Produced connection ID	Yes	No	UINT	
	5 Consumed connection ID	Yes	No	UINT	
	6 Initial comm. Characteristics	Yes	No	BYTE	0x21
	7 Produced connection size	Yes	No	UINT	7
	8 Consumed connection size	Yes	No	UINT	7
	9 Expected packet rate	Yes	Yes	UINT	Default: 2500
	12 Watchdog time-out action	Yes	Yes	USINT	1, 3
	13 Produced connection path length	Yes	No	UINT	0
	14 Produced connection path	Yes	No	(Null)	
	15 Consumed connection path length	Yes	No	UINT	0
	16 Consumed connection path	Yes	No	(Null)	

	DeviceNet service	Parameter option
Services	0x05 Reset	0
	0x0E Get_Attribute_Single	None
	0x10 Set_Attribute_Single	None

Continued on the next page.

Continued from the previous page.

● **Object instance 2**

Section		Information		Number of maximum instance	
Instance type		Polled I/O		1	
Production trigger		Cyclic			
Transport type		Server			
Transport class		2			

ID	Description	Get	Set	Type	Value
Attribute	1 State	Yes	No	USINT	
	2 Instance type	Yes	No	USINT	0x01
	3 Transport class trigger	Yes	No	BYTE	0x82
	4 Produced connection ID	Yes	No	UINT	
	5 Consumed connection ID	Yes	No	UINT	
	6 Initial comm. Characteristics	Yes	No	BYTE	0x01
	7 Produced connection size	Yes	No	UINT	30
	8 Consumed connection size	Yes	No	UINT	6
	9 Expected packet rate	Yes	Yes	UINT	Default: 0
	12 Watchdog time-out action	Yes	No	USINT	0
	13 Produced connection path length	Yes	No	UINT	6
	14 Produced connection path	Yes	No		
	Logic Segment, Class			USINT	0x20
	Class Number			USINT	0x04
	Logic Segment, Instance			USINT	0x24
	Instance Number			USINT	0x01
	Logic Segment, Attributes			USINT	0x30
	Attributes Number			USINT	0x03
	15 Consumed connection path length	Yes	No	UINT	6
	16 Consumed connection path	Yes	No		
	Logic Segment, Class			USINT	0x20
	Class Number			USINT	0x04
	Logic Segment, Instance			USINT	0x24
	Instance Number			USINT	0x65
	Logic Segment, Attributes			USINT	0x30
	Attributes Number			USINT	0x03

DeviceNet service		Parameter option
Services	0x05 Reset	0
	0x0E Get_Attribute_Single	None
	0x10 Set_Attribute_Single	None

■ Controller Object (0x64: 64Hex)

● Object class

Attributes	Not supported
Services	Not supported

● Object instance

	ID	Description	Get	Set	Type	Value
Attributes	1	Input 1_measured value (PV1) monitor	Yes	No	DINT	Refer to P. 40
	2	Input 2_measured value (PV2) monitor	Yes	No	DINT	Refer to P. 40
	3	Unused	—	—	—	—
	4	Unused	—	—	—	—
	5	Unused	—	—	—	—
	6	Input 1_set value (SV1) monitor	Yes	No	DINT	Refer to P. 40
	7	Input 2_set value (SV2) monitor	Yes	No	DINT	Refer to P. 40
	8	Remote input value monitor	Yes	No	DINT	Refer to P. 40
	9	Unused	—	—	—	—
	10	Input 1_burnout state	Yes	No	DINT	Refer to P. 41
	11	Input 2_burnout state	Yes	No	DINT	Refer to P. 41
	12	Unused	—	—	—	—
	13	Event 1 state	Yes	No	DINT	Refer to P. 42
	14	Event 2 state	Yes	No	DINT	Refer to P. 42
	15	Event 3 state	Yes	No	DINT	Refer to P. 42
	16	Event 4 state	Yes	No	DINT	Refer to P. 42
	17	Unused	—	—	—	—
	18	Unused	—	—	—	—
	19	Input 1_manipulated output value (MV1) monitor	Yes	No	DINT	Refer to P. 42
	20	Input 2_manipulated output value (MV2) monitor	Yes	No	DINT	Refer to P. 42
	21	Error code	Yes	No	DINT	Refer to P. 43
	22	Event input state	Yes	No	DINT	Refer to P. 44
	23	Operation mode state	Yes	No	DINT	Refer to P. 45
	24	Memory area soak time monitor	Yes	No	DINT	Refer to P. 46
	25	Input 1_PID/AT transfer	Yes	Yes	DINT	Refer to P. 46
	26	Input 2_PID/AT transfer	Yes	Yes	DINT	Refer to P. 46
	27	Input 1_Auto/Manual transfer	Yes	Yes	DINT	Refer to P. 48
	28	Input 2_Auto/Manual transfer	Yes	Yes	DINT	Refer to P. 48
	29	Remote/Local transfer	Yes	Yes	DINT	Refer to P. 48
	30	RUN/STOP transfer	Yes	Yes	DINT	Refer to P. 48
	31	Memory area selection	Yes	Yes	DINT	Refer to P. 49
	32	Event 1 set value	Yes	Yes	DINT	Refer to P. 49
	33	Event 2 set value	Yes	Yes	DINT	Refer to P. 49
	34	Event 3 set value	Yes	Yes	DINT	Refer to P. 49
	35	Control loop break alarm 1 (LBA1) time	Yes	Yes	DINT	Refer to P. 50

Continued on the next page.

Continued from the previous page.

	ID	Description	Get	Set	Type	Value
Attributes	36	LBA1 deadband	Yes	Yes	DINT	Refer to P. 50
	37	Event 4 set value	Yes	Yes	DINT	Refer to P. 49
	38	Control loop break alarm 2 (LBA2) time	Yes	Yes	DINT	Refer to P. 50
	39	LBA2 deadband	Yes	Yes	DINT	Refer to P. 50
	40	Input 1_set value (SV1)	Yes	Yes	DINT	Refer to P. 52
	41	Input 1_proportional band	Yes	Yes	DINT	Refer to P. 53
	42	Input 1_integral time	Yes	Yes	DINT	Refer to P. 53
	43	Input 1_derivative time	Yes	Yes	DINT	Refer to P. 54
	44	Input 1_control response parameter	Yes	Yes	DINT	Refer to P. 54
	45	Unused	—	—	—	—
	46	Input 2_set value (SV2)	Yes	Yes	DINT	Refer to P. 52
	47	Input 2_proportional band	Yes	Yes	DINT	Refer to P. 53
	48	Input 2_integral time	Yes	Yes	DINT	Refer to P. 53
	49	Input 2_derivative time	Yes	Yes	DINT	Refer to P. 54
	50	Input 2_control response parameter	Yes	Yes	DINT	Refer to P. 54
	51	Unused	—	—	—	—
	52	Input 1_setting change rate limiter (up)	Yes	Yes	DINT	Refer to P. 55
	53	Input 1_setting change rate limiter (down)	Yes	Yes	DINT	Refer to P. 55
	54	Input 2_setting change rate limiter (up)	Yes	Yes	DINT	Refer to P. 55
	55	Input 2_setting change rate limiter (down)	Yes	Yes	DINT	Refer to P. 55
	56	Area soak time	Yes	Yes	DINT	Refer to P. 57
	57	Link area number	Yes	Yes	DINT	Refer to P. 58
	58	Unused	—	—	—	—
	59	Unused	—	—	—	—
	60	Input 1_PV bias	Yes	Yes	DINT	Refer to P. 59
	61	Input 1_PV digital filter	Yes	Yes	DINT	Refer to P. 59
	62	Input 1_PV ratio	Yes	Yes	DINT	Refer to P. 60
	63	Input 1_PV low input cut-off	Yes	Yes	DINT	Refer to P. 61
	64	Input 1_proportional cycle time	Yes	Yes	DINT	Refer to P. 62
	65	Input 1_manual output value	Yes	Yes	DINT	Refer to P. 62
	66	Input 2_PV bias	Yes	Yes	DINT	Refer to P. 59
	67	Input 2_PV digital filter	Yes	Yes	DINT	Refer to P. 59
	68	Input 2_PV ratio	Yes	Yes	DINT	Refer to P. 60
	69	Input 2_PV low input cut-off	Yes	Yes	DINT	Refer to P. 61
	70	Input 2_proportional cycle time	Yes	Yes	DINT	Refer to P. 62
	71	Input 2_manual output value	Yes	Yes	DINT	Refer to P. 62
	72	Set lock level	Yes	Yes	DINT	Refer to P. 63
	73	EEPROM storage state	Yes	No	DINT	Refer to P. 64
	74	EEPROM storage mode	Yes	Yes	DINT	Refer to P. 64
	75	Unused	—	—	—	—
	76	Unused	—	—	—	—
	77	Unused	—	—	—	—

Continued on the next page.

Continued from the previous page.

	ID	Description	Get	Set	Type	Value
Attributes	78	Unused	—	—	—	—
	79	PV1 peak hold value monitor	Yes	No	DINT	Refer to P. 65
	80	PV1 bottom hold value monitor	Yes	No	DINT	Refer to P. 66
	81	PV1 hold reset	Yes	Yes	DINT	Refer to P. 67
	82	PV2 peak hold value monitor	Yes	No	DINT	Refer to P. 65
	83	PV2 bottom hold value monitor	Yes	No	DINT	Refer to P. 66
	84	PV2 hold reset	Yes	Yes	DINT	Refer to P. 67
	85	Interlock release	Yes	Yes	DINT	Refer to P. 67
	86	Auto-zero (Input 1)	Yes	Yes	DINT	Refer to P. 68
	87	Auto calibration (Input 1)	Yes	Yes	DINT	Refer to P. 68
	88	Unused	—	—	—	—

	99	Unused	—	—	—	—
	100	STOP display selection	Yes	Yes	DINT	Refer to P. 69
	101	Bar graph display selection	Yes	Yes	DINT	Refer to P. 69
	102	Bar graph resolution setting	Yes	Yes	DINT	Refer to P. 70
	103	Unused	—	—	—	—
	104	Auto/Manual transfer key operation selection (A/M)	Yes	Yes	DINT	Refer to P. 71
	105	Remote/Local transfer key operation selection (R/L)	Yes	Yes	DINT	Refer to P. 71
	106	RUN/STOP transfer key operation selection (R/S)	Yes	Yes	DINT	Refer to P. 71
	107	Input 1_input type selection	Yes	Yes	DINT	Refer to P. 72
	108	Input 1_display unit selection	Yes	Yes	DINT	Refer to P. 73
	109	Input 1_decimal point position	Yes	Yes	DINT	Refer to P. 74
	110	Input 1_input scale high	Yes	Yes	DINT	Refer to P. 75
	111	Input 1_input scale low	Yes	Yes	DINT	Refer to P. 76
	112	Input 1_input error determination point (high)	Yes	Yes	DINT	Refer to P. 77
	113	Input 1_input error determination point (low)	Yes	Yes	DINT	Refer to P. 78
	114	Input 1_burnout direction	Yes	Yes	DINT	Refer to P. 79
	115	Input 1_square root extraction selection	Yes	Yes	DINT	Refer to P. 80
	116	Power supply frequency selection	Yes	Yes	DINT	Refer to P. 80
	117	Input 2_input type selection	Yes	Yes	DINT	Refer to P. 72
	118	Input 2_display unit selection	Yes	Yes	DINT	Refer to P. 73
	119	Input 2_decimal point position	Yes	Yes	DINT	Refer to P. 74
	120	Input 2_input scale high	Yes	Yes	DINT	Refer to P. 75
	121	Input 2_input scale low	Yes	Yes	DINT	Refer to P. 76
	122	Input 2_input error determination point (high)	Yes	Yes	DINT	Refer to P. 77

Continued on the next page.

Continued from the previous page.

	ID	Description	Get	Set	Type	Value
Attributes	123	Input 2_input error determination point (low)	Yes	Yes	DINT	Refer to P. 78
	124	Input 2_burnout direction	Yes	Yes	DINT	Refer to P. 79
	125	Input 2_square root extraction selection	Yes	Yes	DINT	Refer to P. 80
	126	Event input logic selection	Yes	Yes	DINT	Refer to P. 81
	127	Output logic selection	Yes	Yes	DINT	Refer to P. 84
	128	Output 1 timer setting	Yes	Yes	DINT	Refer to P. 86
	129	Output 2 timer setting	Yes	Yes	DINT	Refer to P. 86
	130	Output 3 timer setting	Yes	Yes	DINT	Refer to P. 86
	131	Output 4 timer setting	Yes	Yes	DINT	Refer to P. 86
	132	Output 5 timer setting	Yes	Yes	DINT	Refer to P. 86
	133	Transmission output 1_type selection	Yes	Yes	DINT	Refer to P. 87
	134	Transmission output 1_scale high	Yes	Yes	DINT	Refer to P. 88
	135	Transmission output 1_scale low	Yes	Yes	DINT	Refer to P. 88
	136	Transmission output 2_type selection	Yes	Yes	DINT	Refer to P. 87
	137	Transmission output 2_scale high	Yes	Yes	DINT	Refer to P. 88
	138	Transmission output 2_scale low	Yes	Yes	DINT	Refer to P. 88
	139	Transmission output 3_type selection	Yes	Yes	DINT	Refer to P. 87
	140	Transmission output 3_scale high	Yes	Yes	DINT	Refer to P. 88
	141	Transmission output 3_scale low	Yes	Yes	DINT	Refer to P. 88
	142	Event 1 type selection	Yes	Yes	DINT	Refer to P. 89
	143	Event 1 hold action	Yes	Yes	DINT	Refer to P. 91
	144	Event 1 differential gap	Yes	Yes	DINT	Refer to P. 93
	145	Event 1 action at input error	Yes	Yes	DINT	Refer to P. 94
	146	Event 1 assignment	Yes	Yes	DINT	Refer to P. 95
	147	Event 2 type selection	Yes	Yes	DINT	Refer to P. 89
	148	Event 2 hold action	Yes	Yes	DINT	Refer to P. 91
	149	Event 2 differential gap	Yes	Yes	DINT	Refer to P. 93
	150	Event 2 action at input error	Yes	Yes	DINT	Refer to P. 94
	151	Event 2 assignment	Yes	Yes	DINT	Refer to P. 95
	152	Event 3 type selection	Yes	Yes	DINT	Refer to P. 89
	153	Event 3 hold action	Yes	Yes	DINT	Refer to P. 91
	154	Event 3 differential gap	Yes	Yes	DINT	Refer to P. 93
	155	Event 3 action at input error	Yes	Yes	DINT	Refer to P. 94
	156	Event 3 assignment	Yes	Yes	DINT	Refer to P. 95
	157	Event 4 type selection	Yes	Yes	DINT	Refer to P. 89
	158	Event 4 hold action	Yes	Yes	DINT	Refer to P. 91
	159	Event 4 differential gap	Yes	Yes	DINT	Refer to P. 93
	160	Event 4 action at input error	Yes	Yes	DINT	Refer to P. 94
	161	Event 4 assignment	Yes	Yes	DINT	Refer to P. 95
	162	Unused	—	—	—	—
	163	Unused	—	—	—	—
	164	Unused	—	—	—	—

Continued on the next page.

Continued from the previous page.

	ID	Description	Get	Set	Type	Value
Attributes	165	Unused	—	—	—	—
	166	Hot/Cold start selection	Yes	Yes	DINT	Refer to P. 95
	167	Input 2_use selection	Yes	Yes	DINT	Refer to P. 96
	168	Unused	—	—	—	—
	169	Unused	—	—	—	—
	170	SV tracking	Yes	Yes	DINT	Refer to P. 96
	171	Input 1_control action type selection	Yes	Yes	DINT	Refer to P. 97
	172	Input 1_integral/derivative time decimal point position selection	Yes	Yes	DINT	Refer to P. 98
	173	Input 1_derivative gain	Yes	Yes	DINT	Refer to P. 98
	174	Input 1_ON/OFF action differential gap (upper)	Yes	Yes	DINT	Refer to P. 99
	175	Input 1_ON/OFF action differential gap (lower)	Yes	Yes	DINT	Refer to P. 100
	176	Input 1_action at input error (high)	Yes	Yes	DINT	Refer to P. 101
	177	Input 1_action at input error (low)	Yes	Yes	DINT	Refer to P. 102
	178	Input 1_manipulated output value at input error	Yes	Yes	DINT	Refer to P. 102
	179	Input 1_output change rate limiter (up)	Yes	Yes	DINT	Refer to P. 103
	180	Input 1_output change rate limiter (down)	Yes	Yes	DINT	Refer to P. 103
	181	Input 1_output limiter high	Yes	Yes	DINT	Refer to P. 105
	182	Input 1_output limiter low	Yes	Yes	DINT	Refer to P. 105
	183	Unused	—	—	—	—
	184	Input 2_control action type selection	Yes	Yes	DINT	Refer to P. 97
	185	Input 2_integral/derivative time decimal point position selection	Yes	Yes	DINT	Refer to P. 98
	186	Input 2_derivative gain	Yes	Yes	DINT	Refer to P. 98
	187	Input 2_ON/OFF action differential gap (upper)	Yes	Yes	DINT	Refer to P. 99
	188	Input 2_ON/OFF action differential gap (lower)	Yes	Yes	DINT	Refer to P. 100
	189	Input 2_action at input error (high)	Yes	Yes	DINT	Refer to P. 101
	190	Input 2_action at input error (low)	Yes	Yes	DINT	Refer to P. 102
	191	Input 2_manipulated output value at input error	Yes	Yes	DINT	Refer to P. 102
	192	Input 2_output change rate limiter (up)	Yes	Yes	DINT	Refer to P. 103
	193	Input 2_output change rate limiter (down)	Yes	Yes	DINT	Refer to P. 103
	194	Input 2_output limiter high	Yes	Yes	DINT	Refer to P. 105
	195	Input 2_output limiter low	Yes	Yes	DINT	Refer to P. 105
	196	Unused	—	—	—	—
	197	Input 1_AT bias	Yes	Yes	DINT	Refer to P. 106
	198	Input 1_AT cycle	Yes	Yes	DINT	Refer to P. 107
	199	Input 1_AT differential gap time	Yes	Yes	DINT	Refer to P. 108

Continued on the next page.

Continued from the previous page.

	ID	Description	Get	Set	Type	Value
Attributes	200	Input 2_AT bias	Yes	Yes	DINT	Refer to P. 106
	201	Input 2_AT cycle	Yes	Yes	DINT	Refer to P. 107
	202	Input 2_AT differential gap time	Yes	Yes	DINT	Refer to P. 108
	203	Unused	—	—	—	—
	204	Unused	—	—	—	—
	205	Unused	—	—	—	—
	206	Unused	—	—	—	—
	207	Setting change rate limiter unit time	Yes	Yes	DINT	Refer to P. 109
	208	Soak time unit selection	Yes	Yes	DINT	Refer to P. 109
	209	Input 1_setting limiter high	Yes	Yes	DINT	Refer to P. 110
	210	Input 1_setting limiter low	Yes	Yes	DINT	Refer to P. 110
	211	Input 2_setting limiter high	Yes	Yes	DINT	Refer to P. 110
	212	Input 2_setting limiter low	Yes	Yes	DINT	Refer to P. 110
	213	ROM version display	Yes	No	DINT	Refer to P. 111
	214	Integrated operating time display	Yes	No	DINT	Refer to P. 111
	215	Holding peak value ambient temperature display	Yes	No	DINT	Refer to P. 111
	216	Unused	—	—	—	—
	217	Unused	—	—	—	—
	218	Unused	—	—	—	—
	219	Unused	—	—	—	—
	220	Unused	—	—	—	—
	221	Unused	—	—	—	—
	222	Unused	—	—	—	—
	223	Unused	—	—	—	—
	224	Alarm lamp lighting condition setting	Yes	Yes	DINT	Refer to P. 112
	225	Unused	—	—	—	—
	226	Input 1_PV1 hold function	Yes	Yes	DINT	Refer to P. 113
	227	Input 2_PV2 hold function	Yes	Yes	DINT	Refer to P. 113
	228	Gain setting (Input 1)	Yes	Yes	DINT	Refer to P. 113
	229	Linearize type selection (Input 1)	Yes	Yes	DINT	Refer to P. 114
	230	Shunt resistance output value (Input 1)	Yes	Yes	DINT	Refer to P. 115
	231	Input 1_PV transfer function	Yes	Yes	DINT	Refer to P. 115
	232	Input 2_PV transfer function	Yes	Yes	DINT	Refer to P. 115
	233	Input 1_MV scaling high (Input 1)	Yes	Yes	DINT	Refer to P. 116
	234	Input 1_MV scaling low (Input 1)	Yes	Yes	DINT	Refer to P. 117
	235	Decimal point position of MV scaling (Input 1)	Yes	Yes	DINT	Refer to P. 117
	236	Input 1_AT action	Yes	Yes	DINT	Refer to P. 117
	237	Input 2_AT action	Yes	Yes	DINT	Refer to P. 117
	238	Input 1_manipulated output value when transferred to Auto from Manual	Yes	No	DINT	Refer to P. 118

Continued on the next page.

Continued from the previous page.

	ID	Description	Get	Set	Type	Value
Attributes	239	Input 2_manipulated output value when transferred to Auto from Manual	Yes	No	DINT	Refer to P. 118
	240	Interlock function	Yes	Yes	DINT	Refer to P. 119
	241	Input 1_MV transfer function	Yes	Yes	DINT	Refer to P. 121
	242	Input 2_MV transfer function	Yes	Yes	DINT	Refer to P. 121
	243	Unused	—	—	—	—
	·	·	·	·	·	·
	·	·	·	·	·	·
	·	·	·	·	·	·
	255	Unused	—	—	—	—
		DeviceNet service	Parameter option			
Services	0x0E	Get_Attribute_Single	None			
	0x10	Set_Attribute_Single	None			



RKC INSTRUMENT INC.

HEADQUARTERS: 16-6, KUGAHARA 5-CHOME, OHTA-KU TOKYO 146-8515 JAPAN

PHONE: 03-3751-9799 (+81 3 3751 9799)

E-mail: info@rkcinst.co.jp

FAX: 03-3751-8585 (+81 3 3751 8585)