

---

---

---

---

*Ethernet [Modbus/TCP]  
Communication Converter*

**COM-JL**  
*[For SRZ]*

***Instruction Manual***

- Ethernet is a registered trademark of Xerox Corp.
- Modbus is a registered trademark of Schneider Electric.
- Windows and Microsoft Internet Explorer are registered trademark of Microsoft Corporation in the U.S.A. and other countries.
- DeviceInstaller is trademark of Lantronix Inc.
- Company names and product names used in this manual are the trademarks or registered trademarks of the respective companies.

Thank you for purchasing this RKC instrument. In order to achieve maximum performance and ensure proper operation of your new instrument, carefully read all the instructions in this manual. Please place this manual in a convenient location for easy reference.

## SYMBOLS

**WARNING** : This mark indicates precautions that must be taken if there is danger of electric shock, fire, etc., which could result in loss of life or injury.

**CAUTION** : This mark indicates that if these precautions and operating procedures are not taken, damage to the instrument may result.



: This mark indicates that all precautions should be taken for safe usage.



: This mark indicates important information on installation, handling and operating procedures.



: This mark indicates supplemental information on installation, handling and operating procedures.



: This mark indicates where additional information may be located.



### WARNING

- An external protection device must be installed if failure of this instrument could result in damage to the instrument, equipment or injury to personnel.
- All wiring must be completed before power is turned on to prevent electric shock, fire or damage to instrument and equipment.
- This instrument must be used in accordance with the specifications to prevent fire or damage to instrument and equipment.
- This instrument is not intended for use in locations subject to flammable or explosive gases.
- Do not touch high-voltage connections such as power supply terminals, etc. to avoid electric shock.
- RKC is not responsible if this instrument is repaired, modified or disassembled by other than factory-approved personnel. Malfunction can occur and warranty is void under these conditions.

## **CAUTION**

- This product is intended for use with industrial machines, test and measuring equipment. (It is not designed for use with medical equipment and nuclear energy.)
- This is a Class A instrument. In a domestic environment, this instrument may cause radio interference, in which case the user may be required to take adequate measures.
- This instrument is protected from electric shock by reinforced insulation. Provide reinforced insulation between the wire for the input signal and the wires for instrument power supply, source of power and loads.
- Be sure to provide an appropriate surge control circuit respectively for the following:
  - If input/output or signal lines within the building are longer than 30 meters.
  - If input/output or signal lines leave the building, regardless the length.
- This instrument is designed for installation in an enclosed instrumentation panel. All high-voltage connections such as power supply terminals must be enclosed in the instrumentation panel to avoid electric shock by operating personnel.
- All precautions described in this manual should be taken to avoid damage to the instrument or equipment.
- All wiring must be in accordance with local codes and regulations.
- All wiring must be completed before power is turned on to prevent electric shock, instrument failure, or incorrect action.

The power must be turned off before repairing work for input break and output failure including replacement of sensor, contactor or SSR, and all wiring must be completed before power is turned on again.
- To prevent instrument damage or failure, protect the power line and the input/output lines from high currents with a protection device such as fuse, circuit breaker, etc.
- Prevent metal fragments or lead wire scraps from falling inside instrument case to avoid electric shock, fire or malfunction.
- Tighten each terminal screw to the specified torque found in the manual to avoid electric shock, fire or malfunction.
- For proper operation of this instrument, provide adequate ventilation for heat dispensation.
- Do not connect wires to unused terminals as this will interfere with proper operation of the instrument.
- Turn off the power supply before cleaning the instrument.
- Do not use a volatile solvent such as paint thinner to clean the instrument. Deformation or discoloration will occur. Use a soft, dry cloth to remove stains from the instrument.
- To avoid damage to instrument display, do not rub with an abrasive material or push front panel with a hard object.
- Do not connect modular connectors to telephone line.

## **NOTICE**

- This manual assumes that the reader has a fundamental knowledge of the principles of electricity, process control, computer technology and communications.
- The figures, diagrams and numeric values used in this manual are only for purpose of illustration.
- RKC is not responsible for any damage or injury that is caused as a result of using this instrument, instrument failure or indirect damage.
- RKC is not responsible for any damage and/or injury resulting from the use of instruments made by imitating this instrument.
- Periodic maintenance is required for safe and proper operation of this instrument. Some components have a limited service life, or characteristics that change over time.
- Every effort has been made to ensure accuracy of all information contained herein. RKC makes no warranty expressed or implied, with respect to the accuracy of the information. The information in this manual is subject to change without prior notice.
- No portion of this document may be reprinted, modified, copied, transmitted, digitized, stored, processed or retrieved through any mechanical, electronic, optical or other means without prior written approval from RKC.¥

# CONTENTS

---

	Page
<b>1. OUTLINE .....</b>	<b>1</b>
1.1 Product Check .....	2
1.2 Model Code .....	2
1.3 Parts Description .....	3
<b>2. HANDLING PROCEDURES.....</b>	<b>4</b>
<b>3. MOUNTING.....</b>	<b>5</b>
3.1 Mounting Cautions.....	5
3.2 Dimensions.....	6
3.3 DIN Rail Mounting .....	6
3.4 Panel Mounting.....	7
<b>4. WIRING.....</b>	<b>8</b>
4.1 Wiring Cautions .....	8
4.2 Terminal Configuration .....	9
4.3 Connection to Ethernet .....	10
4.4 Connection to the Controllers .....	12
4.5 System Configuration Example.....	13
4.6 Installation of Termination Resistor.....	15
<b>5. COMMUNICATION SETTING .....</b>	<b>17</b>
<b>6. IP ADDRESS SETTING.....</b>	<b>18</b>
6.1 Setting by the Web Browser .....	18
6.2 Setting by Telnet.....	21
6.3 Setting by DeviceInstaller .....	26
6.4 Setting by the DIP Switch .....	28

---



	Page
<b>7. MODBUS/TCP PROTOCOL.....</b>	<b>32</b>
7.1 Message Configuration .....	32
7.2 Function Code .....	34
7.3 Server (COM-JL) Responses.....	34
7.4 Message Format.....	36
7.4.1 Read holding registers [03H] .....	36
7.4.2 Write single register [06H] .....	38
7.4.3 Diagnostics (Loopback test) [08H] .....	39
7.4.4 Write multiple registers [10H] .....	40
7.4.5 Read/write multiple registers [17H].....	42
7.5 Data Configuration.....	44
7.5.1 Data scale .....	44
7.5.2 Caution for handling communication data .....	48
7.5.3 How to use memory area data .....	49
<b>8. COMMUNICATION DATA LIST .....</b>	<b>51</b>
8.1 Reference to Communication Data List .....	51
8.2 SRZ (Z-TIO/Z-DIO module) Communication Data Items .....	53
8.3 Memory Area Data Items .....	80
8.4 COM-JL Communication Data Items .....	83
<b>9. TROUBLESHOOTING.....</b>	<b>89</b>
<b>10. SPECIFICATIONS .....</b>	<b>92</b>

# 1. OUTLINE

This manual describes the communication specifications, mounting, wiring, setting and data instructions for the Ethernet [Modbus/TCP] Communication Converter COM-JL [For SRZ].

Ethernet [Modbus/TCP] Communication Converter COM-JL [For SRZ] (hereafter called COM-JL) is communication converter to connect the RKC module type temperature controller SRZ (hereafter called Controller) to Ethernet.

The COM-JL supports Modbus/TCP protocol.

-  Modbus/TCP is an open field network provided with the Modbus protocol on the TCP/IP protocol of Ethernet.
-  The data request side is called “client” (such as computer) and the data response (supply) side is called “server” (COM-JL).
-  Basically, one client corresponds to one server (COM-JL) (i.e. one to one). However, one client can communicate with two or more servers depending on the program on the client side, but two or more clients cannot communicate with one server.

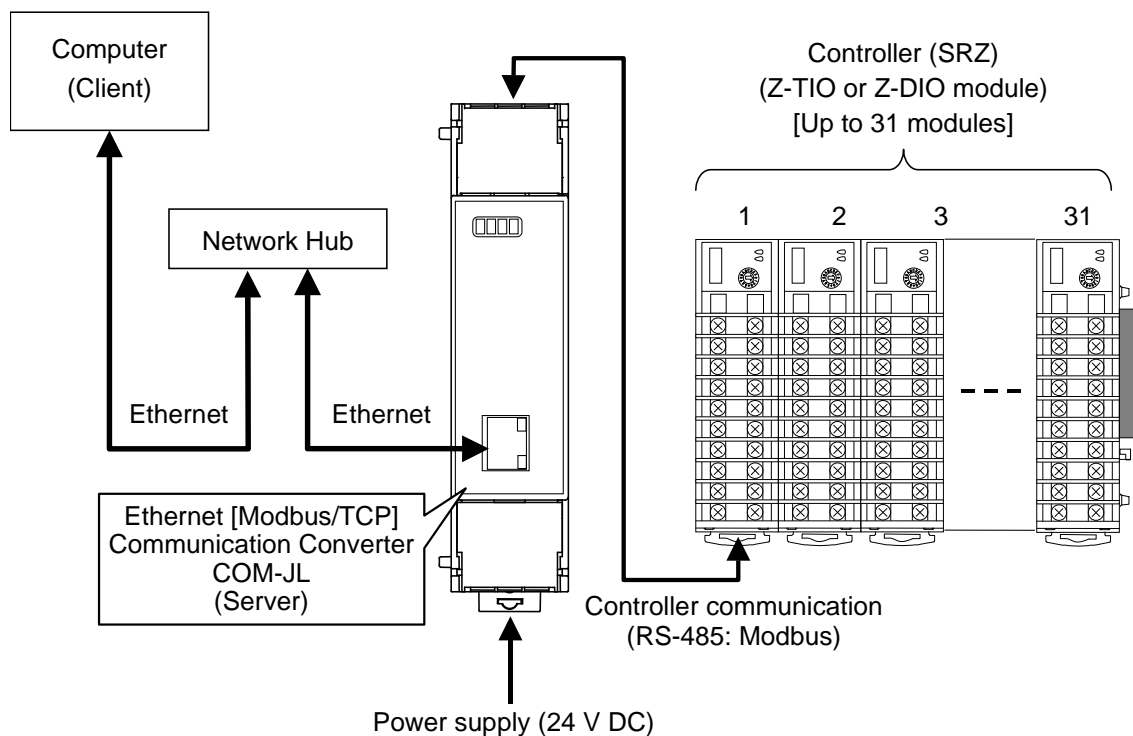

## 1.1 Product Check

Before using this product, check each of the following.

- Model code
- Check that there are no scratch or breakage in external appearance (case, front panel, terminal, etc).
- Check that all of the accessories delivered are complete. (See below)

Accessories	Q'TY	Remarks
<input type="checkbox"/> COM-JL [For SRZ] Installation Manual (IMR01Y25-E□)	1	Enclosed with instrument
<input type="checkbox"/> COM-JL [For SRZ] Quick Instruction Manual (IMR01Y29-E□)	1	Enclosed with instrument
<input type="checkbox"/> COM-JL [For SRZ] Communication Data List (IMR01Y33-E□)	1	Enclosed with instrument
<input type="checkbox"/> COM-JL [For SRZ] Instruction Manual (IMR01Y37-E2)	1	This manual (sold separately)



If any of the products are missing, damaged, or if your manual is incomplete, please contact RKC sales office or the agent.

## 1.2 Model Code

Check whether the delivered product is as specified by referring to the following model code list. If the product is not identical to the specifications, please contact RKC sales office or the agent.

**COM- JL- 1 \* 02**  
(1)    (2)

### (1) Communication type

1: Modbus/TCP

### (2) Corresponding to the RKC controller

02: SRZ



### 1.3 Parts Description

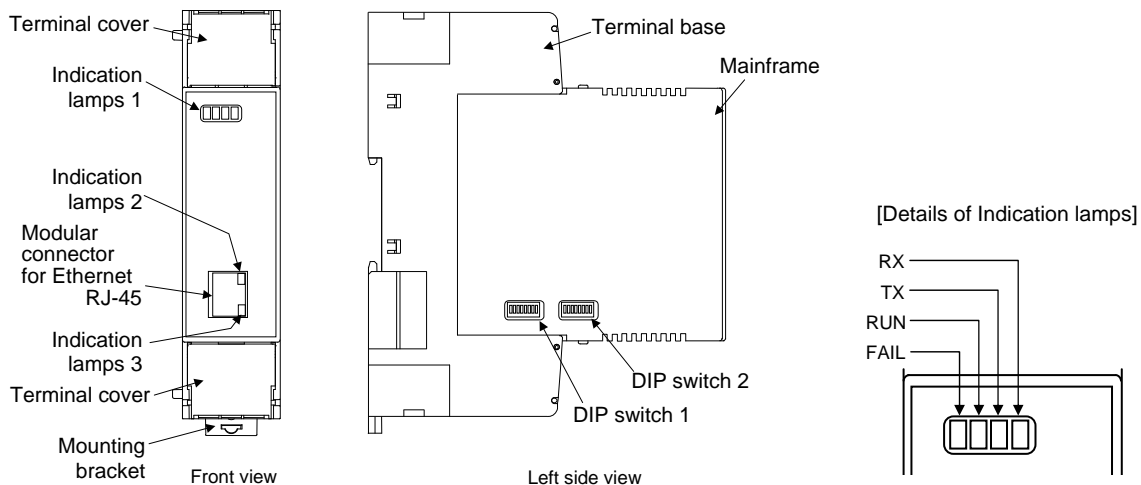

● **Indication lamps 1**

FAIL [Red]	<ul style="list-style-type: none"> <li>Instrument normality: Turns off</li> <li>Instrument abnormality: Turns on</li> </ul>
RUN [Green]	<ul style="list-style-type: none"> <li>When normal: Turns on</li> <li>Operation error: Flashes slowly</li> <li>Data collection just after the power is turned on: Flashes rapidly</li> </ul>
TX [Green]	During data send: Flashes
RX [Green]	During data receive: Flashes

● **Indication lamps 2**

Link	10BASE-T link: Amber lamp: ON	100BASE-TX link: Green lamp: ON
------	-------------------------------	---------------------------------

● **Indication lamps 3**

Activity	Half-duplex; activity: Amber lamp: ON	Full-duplex; activity: Green lamp: ON
----------	---------------------------------------	---------------------------------------

● **Connector**

Ethernet	Modular connector for Ethernet RJ-45
----------	--------------------------------------

● **Switches**

DIP switch 1	Set the communication speed for controller communication
DIP switch 2	<b>Don't change this setting</b> (Use it only in IP address setting by DIP switch)

● **Others**

Terminal cover	Terminal covers above and below the COM-JL
Mounting bracket	<ul style="list-style-type: none"> <li>Used for the DIN rail mounting</li> <li>When panel mounted, two mounting brackets are required for the upper and lower sides (one required for the upper side: separately sold).</li> </ul>
Terminal base	Part of the terminal and base of COM-JL (There is the termination resistor setting switch in the inside of terminal base)
Mainframe	Part of the mainframe of COM-JL

## 2. HANDLING PROCEDURES

---

Conduct necessary setting before operation according to the procedure described below.

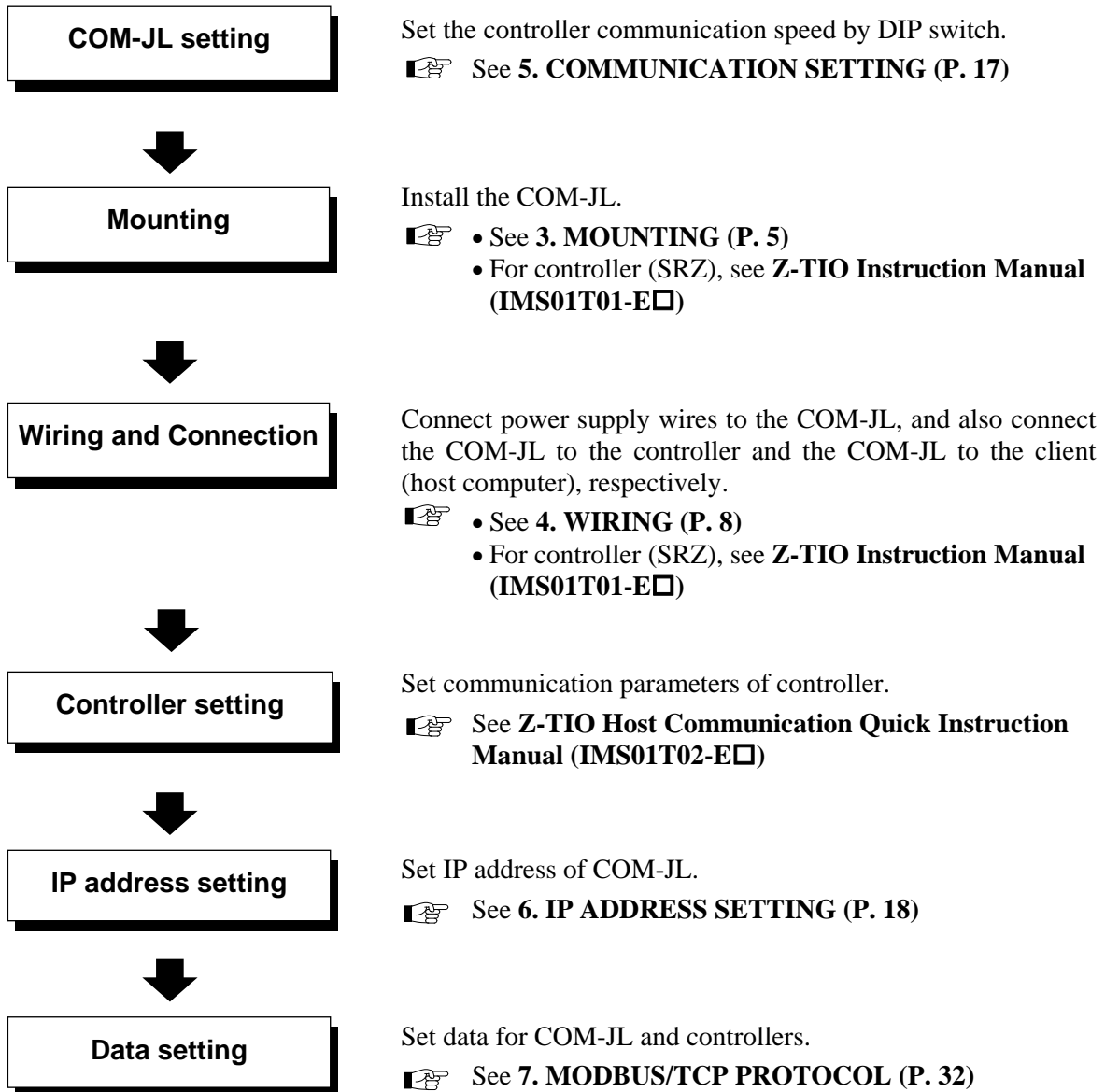

# 3. MOUNTING

---

This chapter describes installation environment, mounting cautions, dimensions and mounting procedures.



## WARNING

To prevent electric shock or instrument failure, always turn off the power before mounting or removing the instrument.

### 3.1 Mounting Cautions

- (1) This instrument is intended to be used under the following environmental conditions.  
**(IEC61010-1)**  
[OVERVOLTAGE CATEGORY II, POLLUTION DEGREE 2]
- (2) Use this instrument within the following ambient temperature and ambient humidity.
  - Allowable ambient temperature:  $-10$  to  $+50$  °C
  - Allowable ambient humidity: 5 to 95 %RH  
(Absolute humidity: MAX.W.C 29.3 g/m<sup>3</sup> dry air at 101.3 kPa)
  - Installation environment conditions: Indoor use  
Altitude up to 2000 m
- (3) Avoid the following conditions when selecting the mounting location.
  - Rapid changes in ambient temperature which may cause condensation.
  - Corrosive or inflammable gases.
  - Direct vibration or shock to the mainframe.
  - Water, oil, chemicals, vapor or steam splashes.
  - Excessive dust, salt or iron particles.
  - Excessive induction noise, static electricity, magnetic fields or noise.
  - Direct air flow from an air conditioner.
  - Exposure to direct sunlight.
  - Excessive heat accumulation.
- (4) Take the following points into consideration when mounting this instrument.
  - Ensure at least 50 mm space on top and bottom of the instrument for maintenance and environmental reasons.
  - Do not mount this instrument directly above equipment that generates large amount of heat (heaters, transformers, semi-conductor functional devices, large-wattage resistors).
  - If the ambient temperature rises above 50 °C, cool this instrument with a forced air fan, cooler, or the like. However, do not allow cooled air to blow this instrument directly.
  - In order to improve safety and the immunity to withstand noise, mount this instrument as far away as possible from high voltage equipment, power lines, and rotating machinery.
    - High voltage equipment: Do not mount within the same panel.
    - Power lines: Separate at least 200 mm.
    - Rotating machinery: Separate as far as possible.

(5) This instrument is permanently connected to equipment, please take the following points.

- A switch or circuit-breaker shall be included in the building installation.
- It shall be in close proximity to the equipment and within easy reach of the operator.
- It shall be marked as the disconnecting device for the equipment.

### 3.2 Dimensions

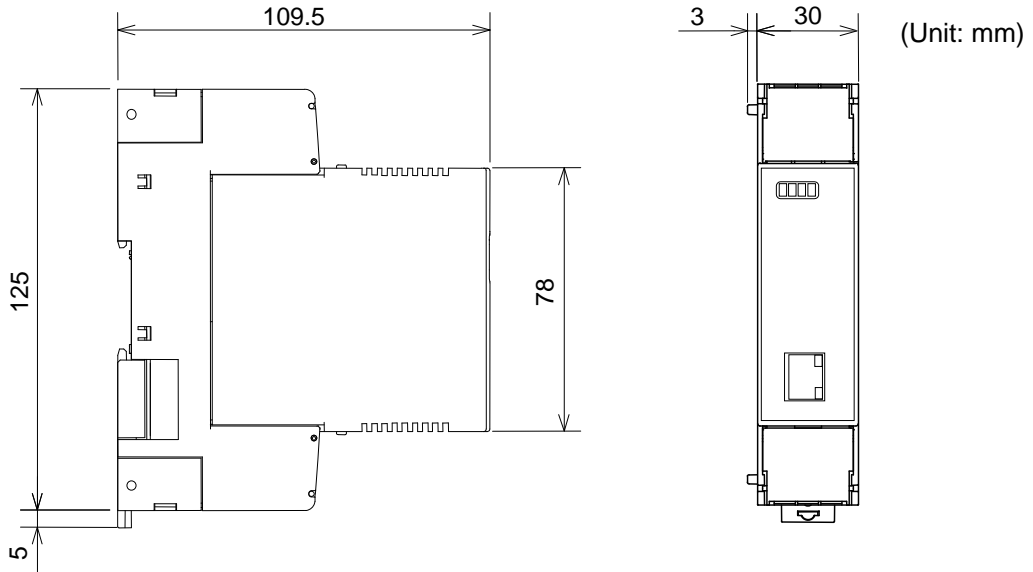

### 3.3 DIN Rail Mounting

#### ■ Mounting procedures

1. Pull down the mounting bracket at the bottom of the instrument (A). Attach the hooks on the top of the instrument to the DIN rail and push the lower section into place on the DIN rail (B).
2. Slide the mounting bracket up to secure the instrument to the DIN rail (C).

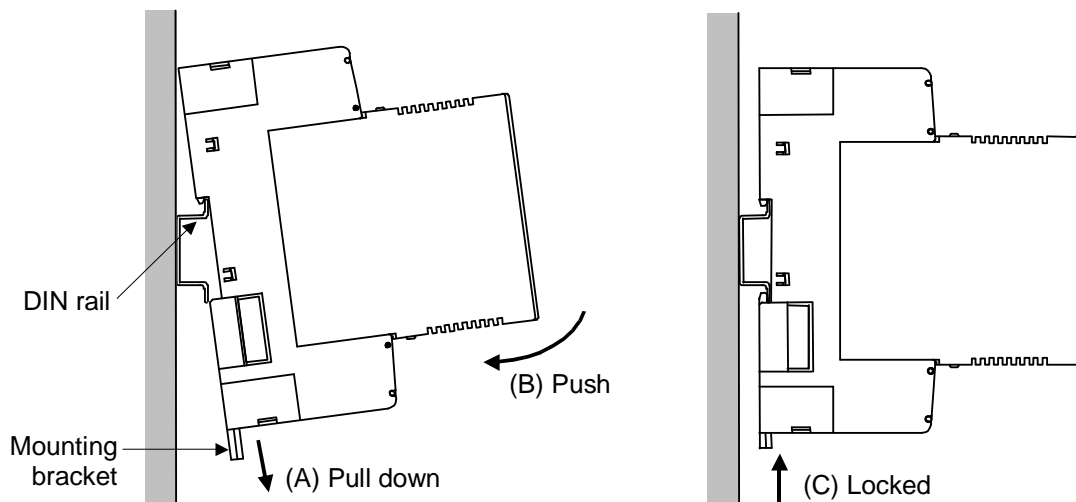

### ■ Removing procedures

1. Turn the power OFF.
2. Remove the wiring.
3. Pull down a mounting bracket with a blade screwdriver (A). Lift the instrument from bottom, and take it off (B).

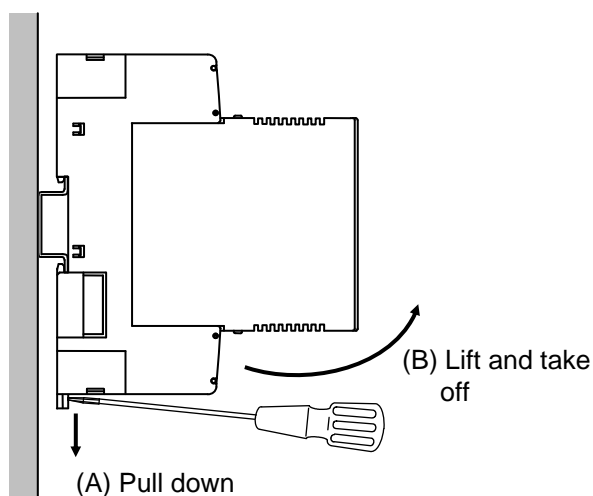

## 3.4 Panel Mounting

### ■ Mounting procedures

1. Pull down the mounting bracket (A) until locked and that a mounting hole appears.
2. Prepare one mounting bracket per instrument (B) sold separately (KSRX-55) and then insert it in the rear of the terminal board at top of the instrument until locked but a mounting hole does not disappear.
3. Mount each module directly on the panel with screws which are inserted in the mounting holes of the top and bottom mounting brackets.

Recommended tightening torque: 0.3 N·m (3 kgf·cm)



The customer needs to provide the M3 size screws. Select the screw length that matches the mounting panel.

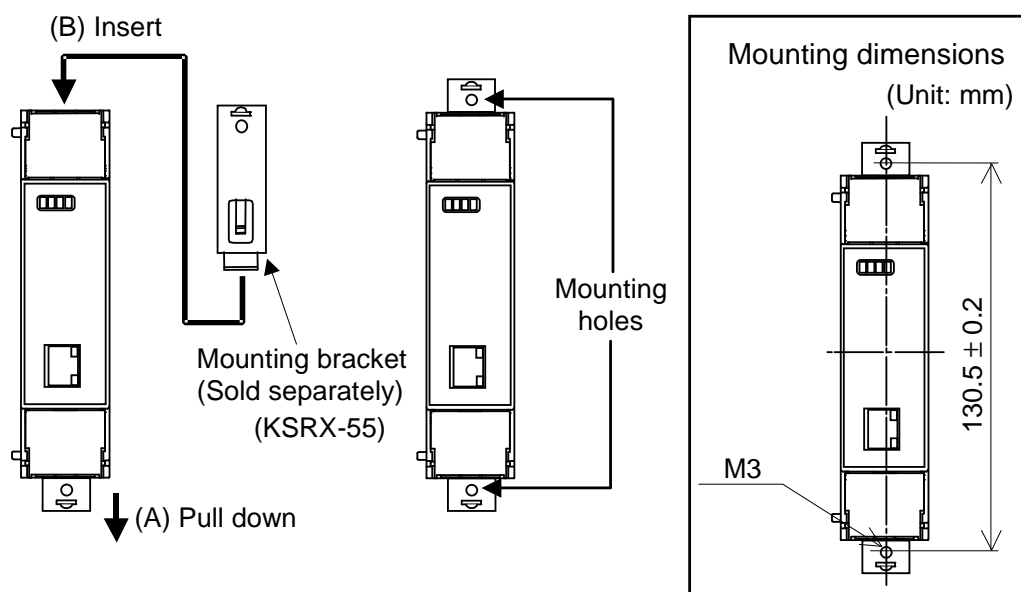

# 4. WIRING

---

This chapter describes wiring cautions, terminal configuration and connections.

## 4.1 Wiring Cautions



### WARNING

To prevent electric shock or instrument failure, do not turn on the power until all the wiring is completed.

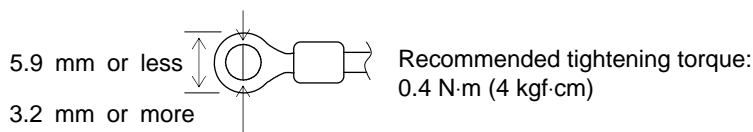

- To avoid noise induction, keep communication signal wire away from instrument power line, load lines and power lines of other electric equipment.
- If there is electrical noise in the vicinity of the instrument that could affect operation, use a noise filter.
  - Shorten the distance between the twisted power supply wire pitches to achieve the most effective noise reduction.
  - Always install the noise filter on a grounded panel. Minimize the wiring distance between the noise filter output and the instrument power supply terminals to achieve the most effective noise reduction.
  - Do not connect fuses or switches to the noise filter output wiring as this will reduce the effectiveness of the noise filter.
- Power supply wiring must be twisted and have a low voltage drop.
- For an instrument with 24 V power supply, supply power from a SELV circuit.
- A suitable power supply should be considered in the end-use equipment. The power supply must be in compliance with a limited-energy circuits (maximum available current of 8 A).
- Use the solderless terminal appropriate to the screw size (M3).

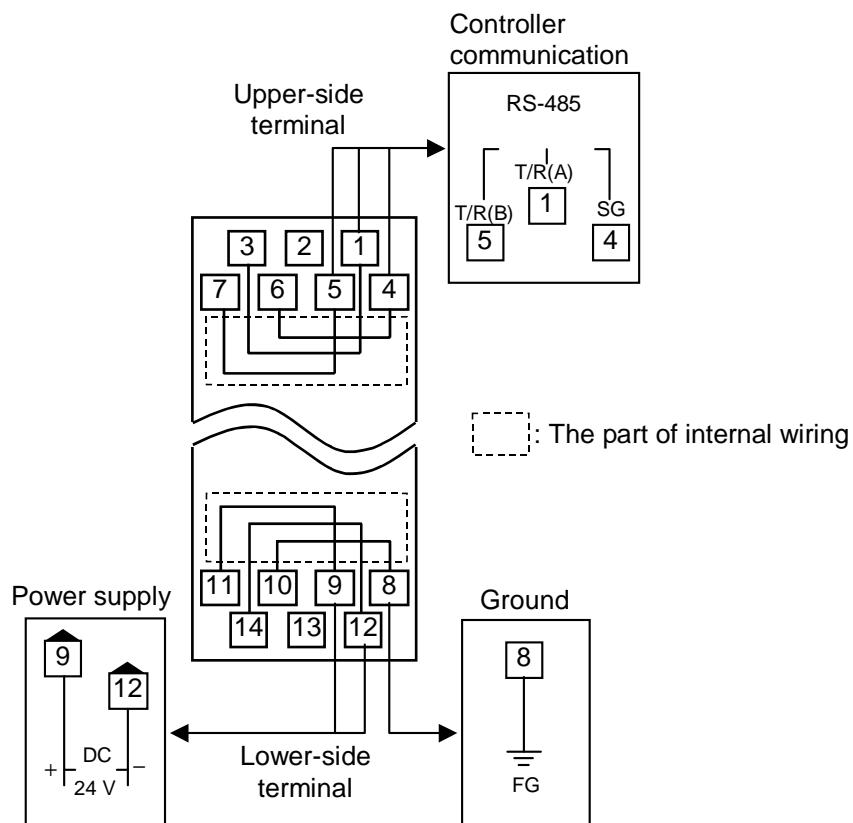

## 4.2 Terminal Configuration

The terminal layout is as follows.



-  As controller communication terminal Nos. 1, 4 and 5 are internally connected to terminal Nos. 3, 6 and 7, any terminals can be used.
-  As ground and power supply terminal Nos. 8, 9 and 12 are internally connected to terminal Nos. 10, 11 and 14, any terminals can be used.
-  Terminal No. 2 and No. 13 is not used.

## 4.3 Connection to Ethernet

Connect COM-JL to Ethernet.

### ■ Pin layout of connector

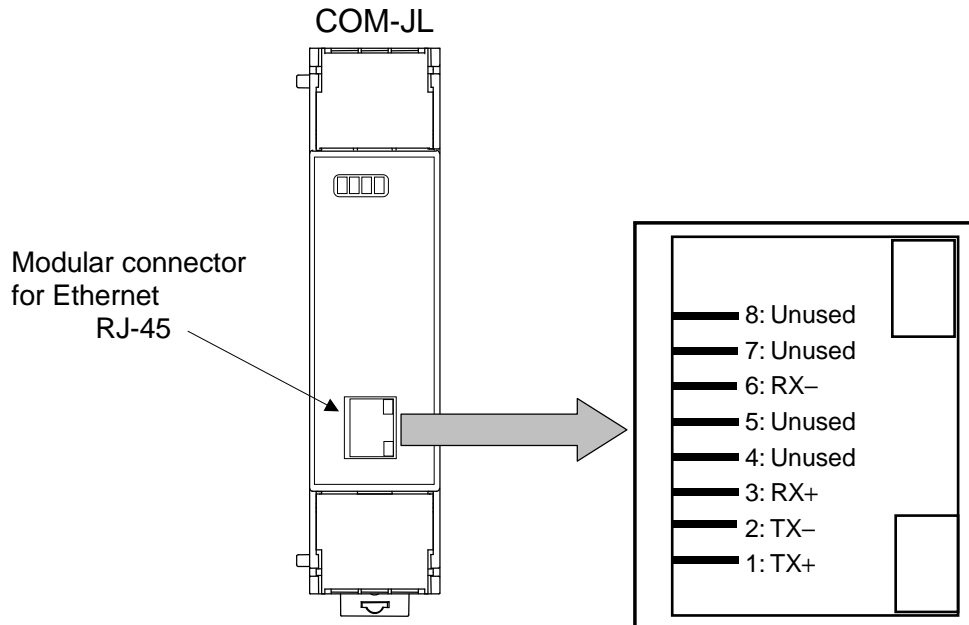

### ■ Connector pin number and signal details

Pin No.	Signal name	Symbol
1	Send data +	TX+
2	Send data -	TX-
3	Receive data +	RX+
4	Unused	—
5	Unused	—
6	Receive data -	RX-
7	Unused	—
8	Unused	—



The cable must be provided by the customer.

Used cable: The cable is based on the 10BASE-T or the 100BASE-TX standard of Ethernet.

Used connector: RJ-45 type



### ■ Wiring example

#### ● When directly connected to client

Use a cross cable when directly connected to the client (such as computer).

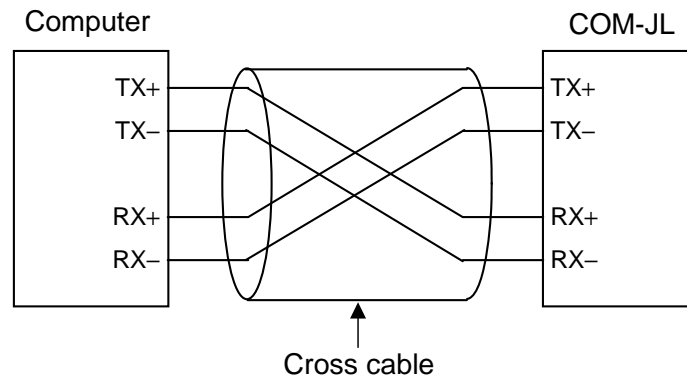

#### ● When use network hub

Use straight cables when connected to the network hub.

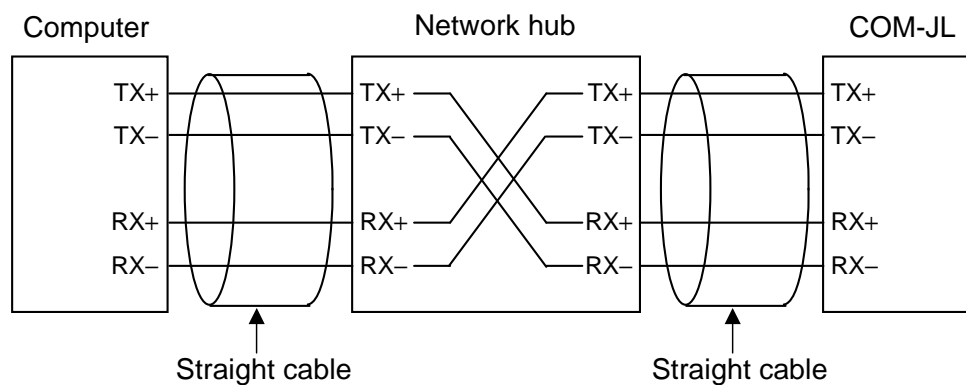

Cross cables may be used depending on the connecting device used. Therefore, follow the instructions for the respective device.

## 4.4 Connection to the Controllers

Conduct wiring between the COM-JL and controller (SRZ) as shown in the following.

### ■ SRZ (Z-TIO/Z-DIO module) communication terminal number and signal details

Terminal No.	Signal name	Symbol
3	Send/receive data	T/R (A)
4	Send/receive data	T/R (B)
5	Signal ground	SG

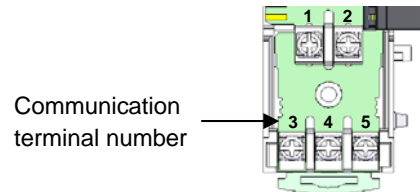

### ■ Wiring

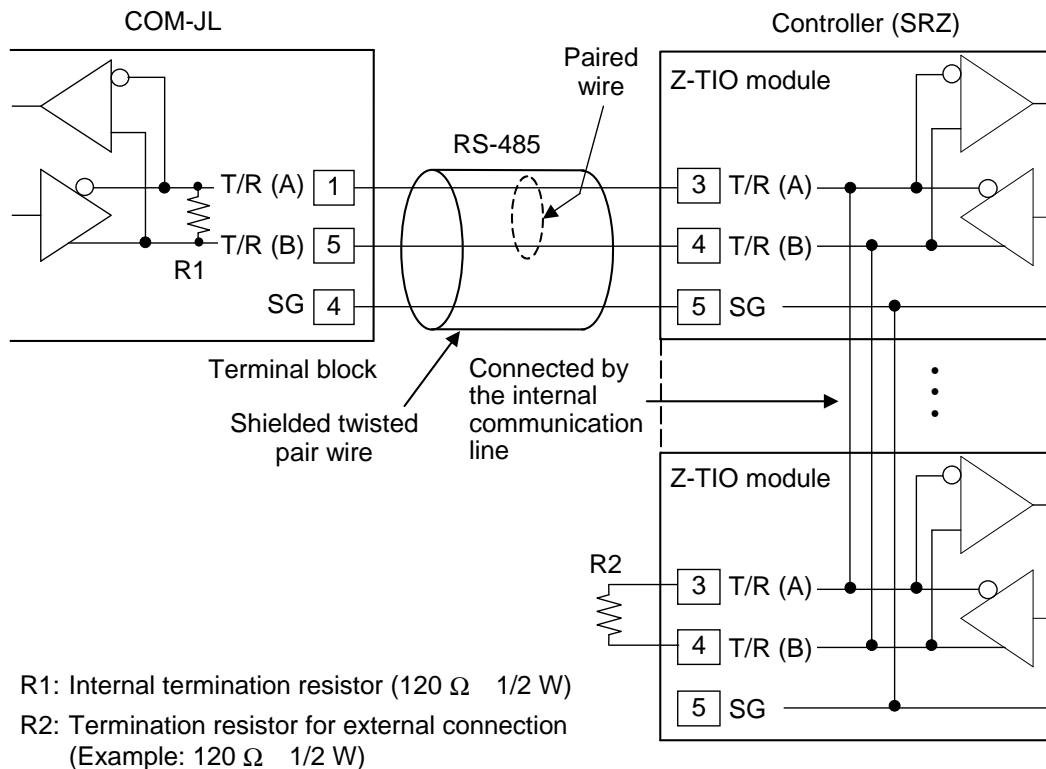

Up to 16 Z-TIO modules can be connected.

The maximum number of SRZ modules (including other function modules) on the same communication line is 31.



The cable must be provided by the customer.



The termination resistor existing within the COM-JL can be connected or disconnected by the switch. (Factory set value: Termination resistor connected)

[See 4.6 Installation of Termination Resistor (P. 15)]

## 4.5 System Configuration Example

### ■ When directly connected to client

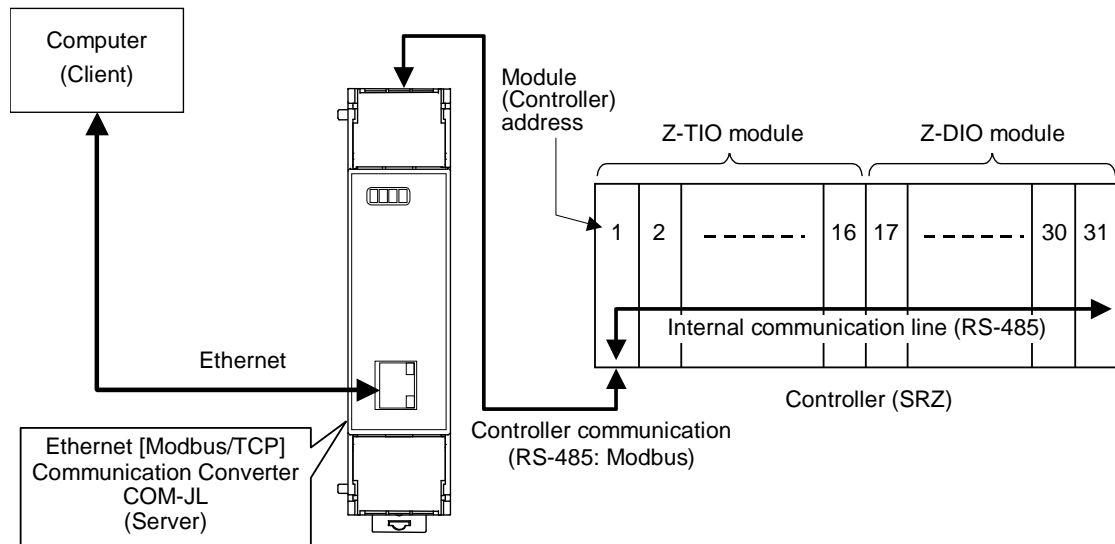

Up to 31 modules (Z-TIO/Z-DIO module) can be connected to one COM-JL. However, the maximum joinable number of functional modules of the same type is 16.

### ■ When use network hub

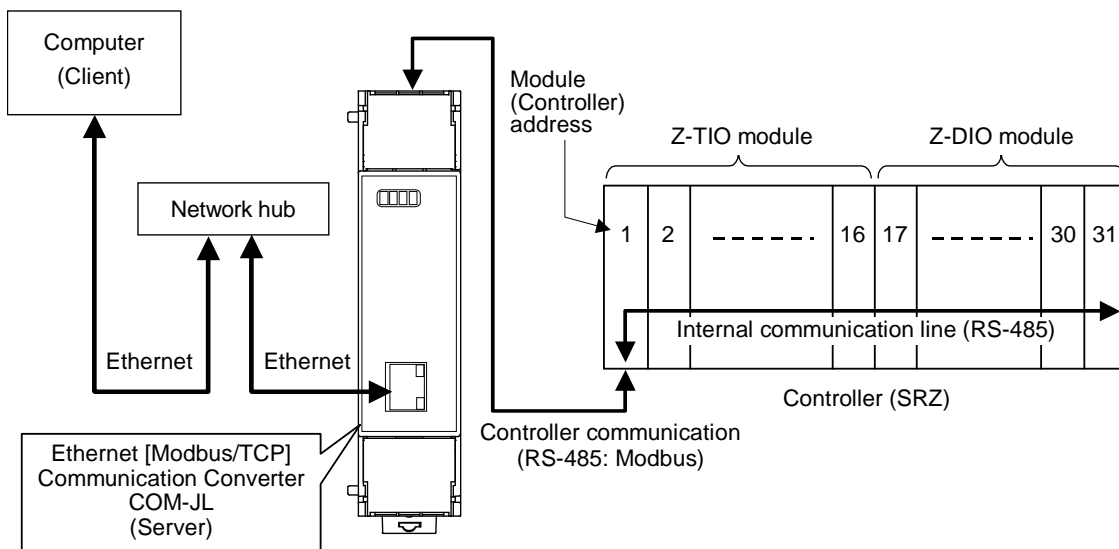

Up to 31 modules (Z-TIO/Z-DIO module) can be connected to one COM-JL. However, the maximum joinable number of functional modules of the same type is 16.



Basically, one client corresponds to one server (COM-JL) (i.e. one to one). However, one client can communicate with two or more servers depending on the program on the client side, but two or more clients cannot communicate with one server.

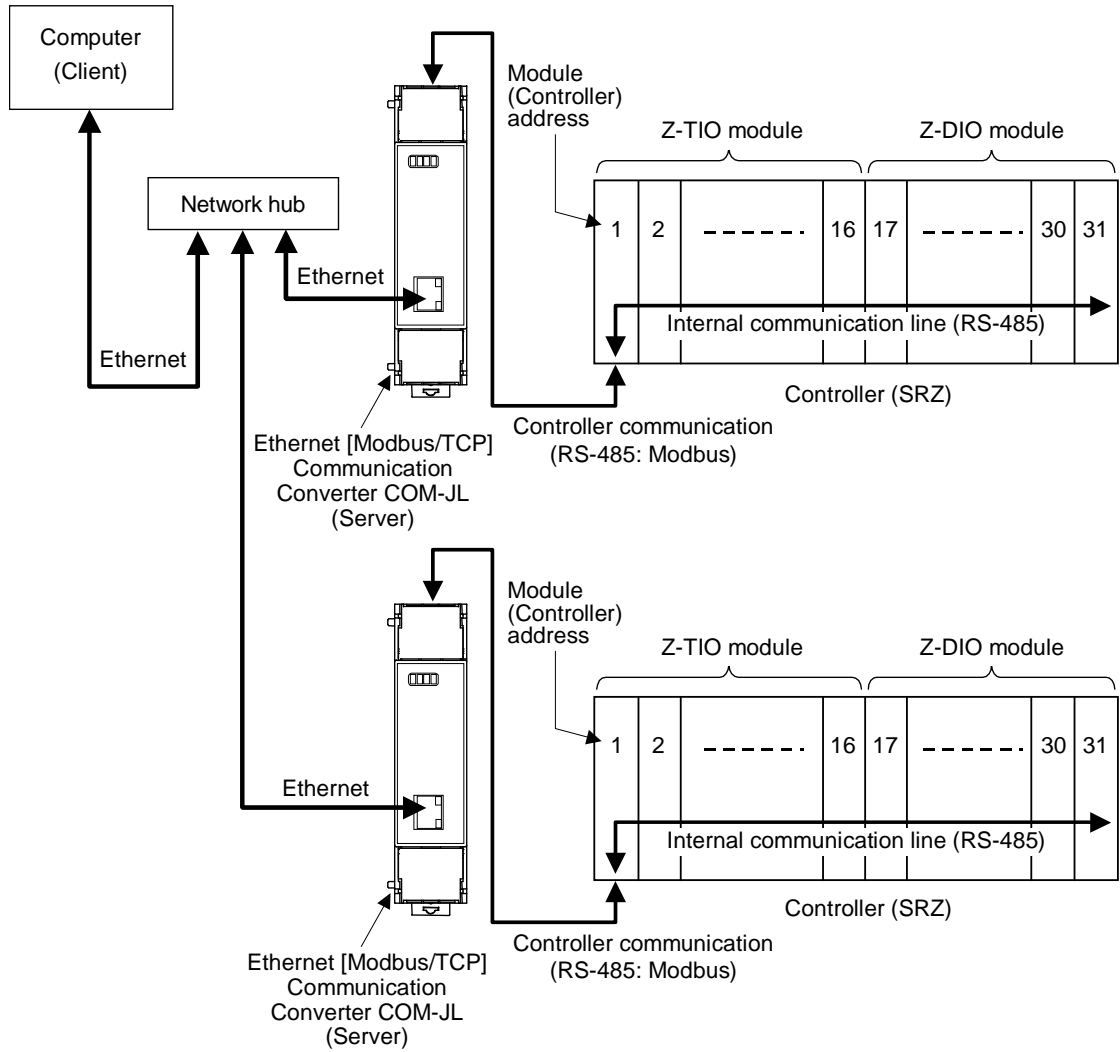

## 4.6 Installation of Termination Resistor

Procedure for setting a termination resistor to controller communication (RS-485) and its setting position are described in the following.

### ■ Termination resistor setting position

If the COM-JL is connected to the extreme end of the communication line, install one termination resistor each to the COM-JL and the controller (module of the SRZ) located most distantly from the COM-JL.

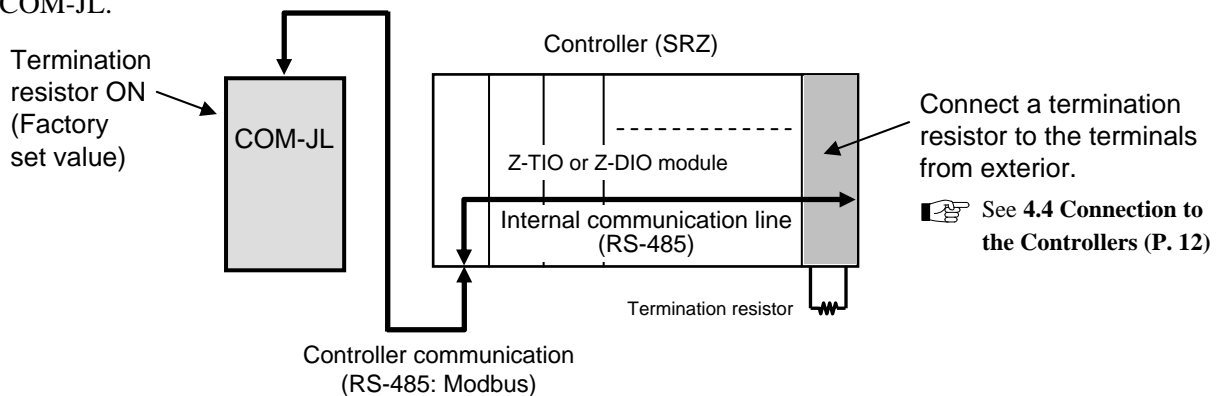

### ■ Setting procedure of termination resistor

As the COM-JL is internally provided with a selector switch for choosing the ON/OFF of a termination resistor, it is not required to externally install the termination resistor.

(Factory set value: Termination resistor connected)

1. Turn off the power supply of the COM-JL.

**Do not separate the mainframe from terminal base with the power turned on. If so, instrument failure may result.**

2. Pull out the mainframe itself toward you while pushing the locks at its top and bottom (1), and then separate it from the terminal base (2).

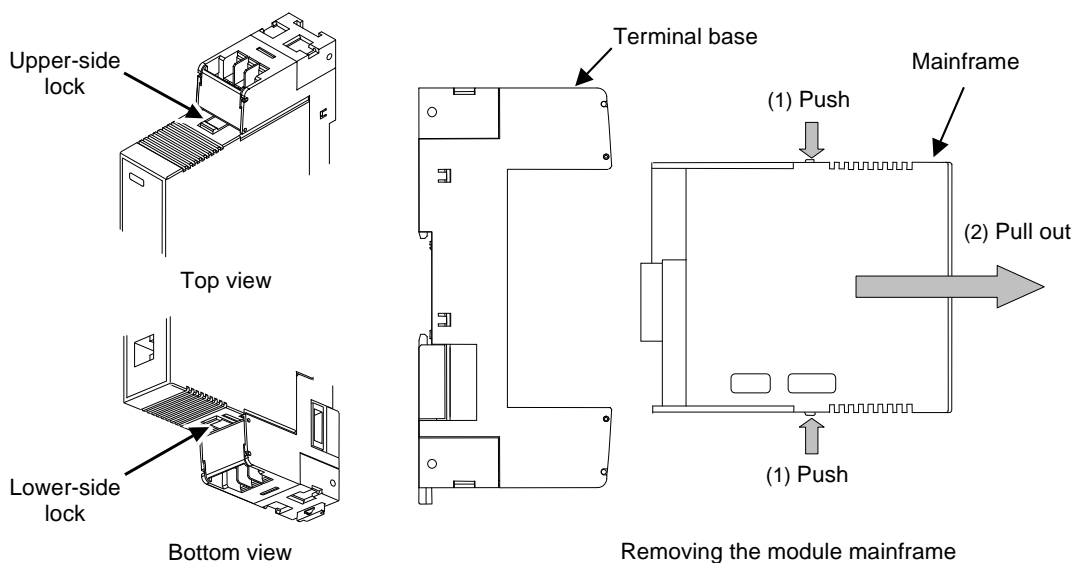

3. Turn on the termination resistor transfer switch in the terminal base.  
The COM-JL is shipped from the factory with the selector switch set to “ON: Termination resistor connected.”

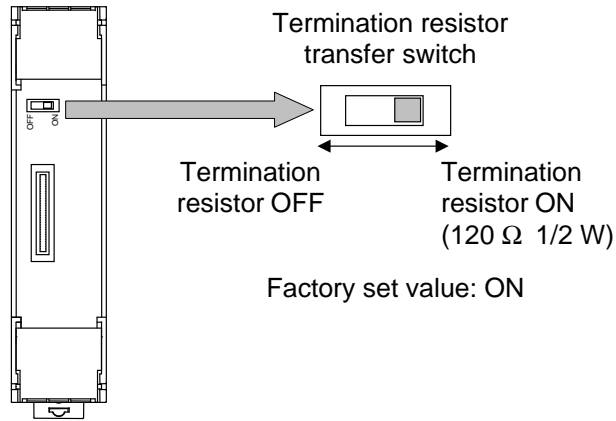

A terminal base of the state which removed module mainframe

4. Push the mainframe thus separated in the terminal base until firmly locked.

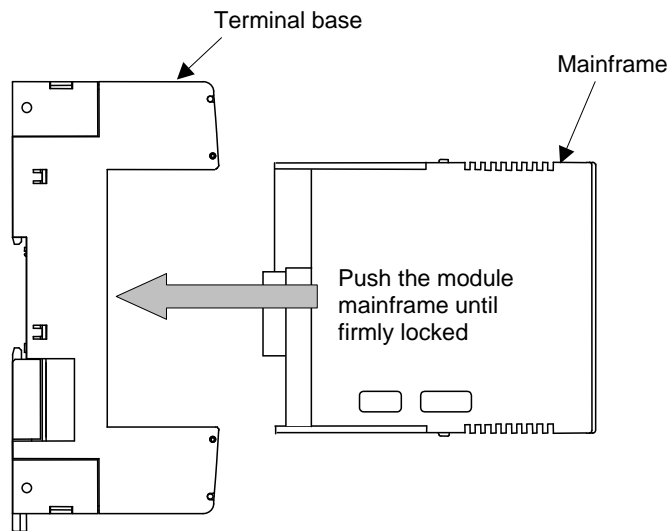

Mounting the module mainframe

# 5. COMMUNICATION SETTING

The speed of communication with the controller (SRZ) is set by the dip switch at the left side of the COM-JL.

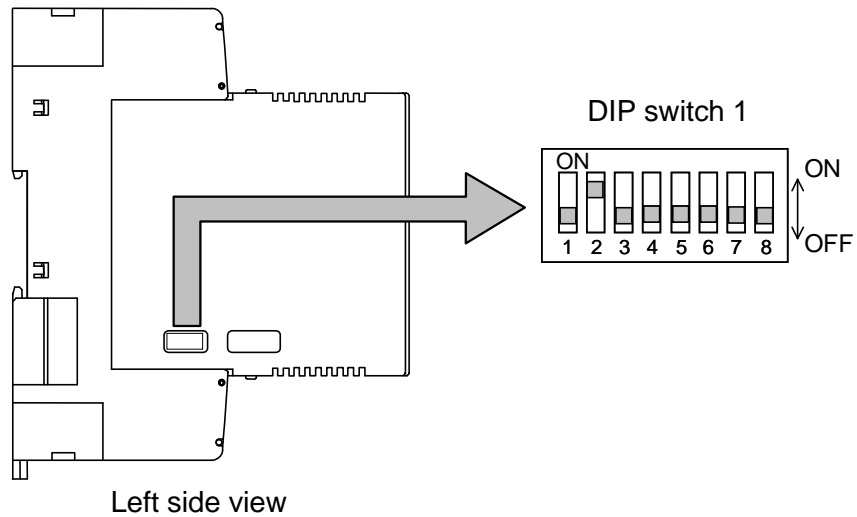

1	2	Controller communication speed
OFF	OFF	38400 bps
ON	OFF	9600 bps
OFF	ON	19200 bps
ON	ON	38400 bps

Factory set value: 19200 bps

3	4	5	6	7	8	
OFF	OFF	OFF	OFF	OFF	OFF	Fixed (Do not change the factory set value)



Another controller communication setting  
Data bit configuration: Data 8-bit, Without parity bit, Stop 1-bit



**Do not change the setting of DIP switch 2.**  
(Use it only in IP address setting by DIP switch)

# 6. IP ADDRESS SETTING

---

Set an IP address of a COM-JL.

Four types of IP address setting are available: “setting by Web browser,” “setting by Telnet,” “setting by DeviceInstaller” and “setting by DIP switch.”



**Confirm the IP address number to the network administrator of the network (LAN) to which the COM-JL is connected.**



If the IP address has been changed from the factory set value (192.168.1.1) and you do not know the current address, set the IP address using DeviceInstaller or the DIP switches.

## 6.1 Setting by the Web Browser

It is possible to set the IP address by using the Web browser (such as Internet Explorer).

### ■ Preparations before setting

When setting the IP address by Web browser, it is necessary to coincide the 1st to 3rd bytes and masking range of the IP address of the client (computer) which starts Web browser with those of the IP address of the COM-JL.

1. Connect the COM-JL and client, and then turn on the power.



For wiring procedure, see **4. WIRING (P. 8)**.

2. Change the IP address of the client.

The IP address of the COM-JL is set to a factory set value of “192.168.1.1.” As it is necessary to coincide the 1st to 3rd byte values of this IP address with those of the IP address of the client.

Setting value: 192.168.1.  (  : Any value in the range of 0 to 255, but other than 1 )

3. Change the subnet mask of the client.

As the subnet mask of the COM-JL is “255.255.255.0,” also change the subnet mask of the client.

Setting value: 255.255.255.0



After the IP address of the server is set, return the present IP address of the client to the original address or change to the address meeting the network to be connected.



It is possible to set the IP address of the COM-JL using the client already connected to the network. **However, as the IP address of the client is changed, that client is disconnected from the network so far connected.**

In addition, when setting the IP address by this method, confirm to the network administrator whether or not no problem arises.



## ■ Setting example

An example of setting the IP address of the COM-JL to “192.168.1.3” is shown in the following.

1. Start the Web browser; enter the present IP address “192.168.1.1” into the address bar and then press the Enter key.



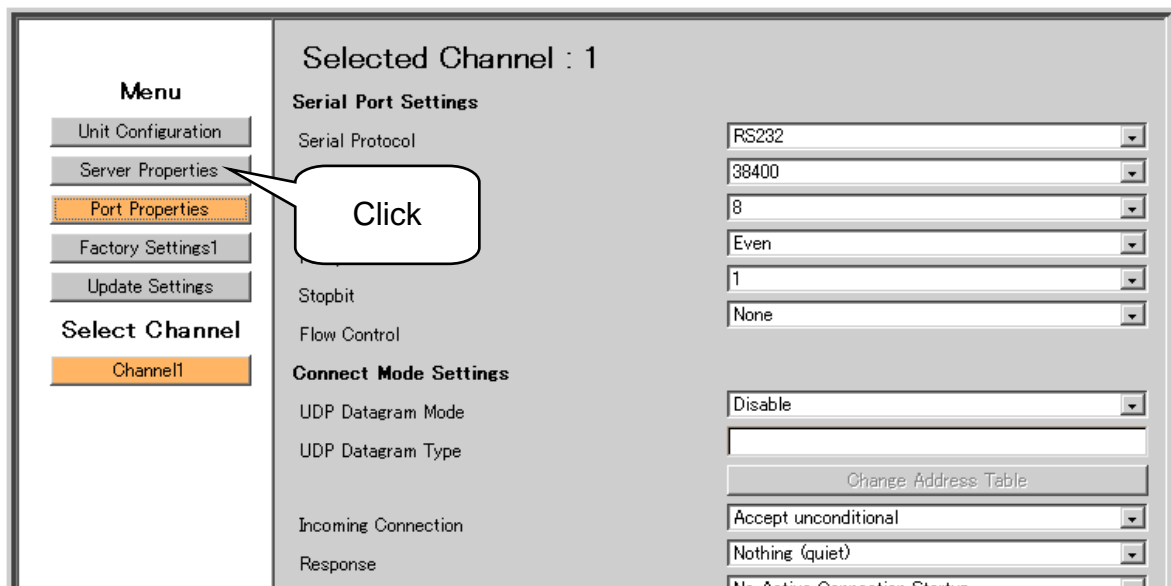

2. The initial setting applet starts. “Selected Channel: 1” is displayed on the main display with “Port Properties” selected on the Menu display on the left side of the screen. Under this condition, click the **Server Properties** button on the Menu display.

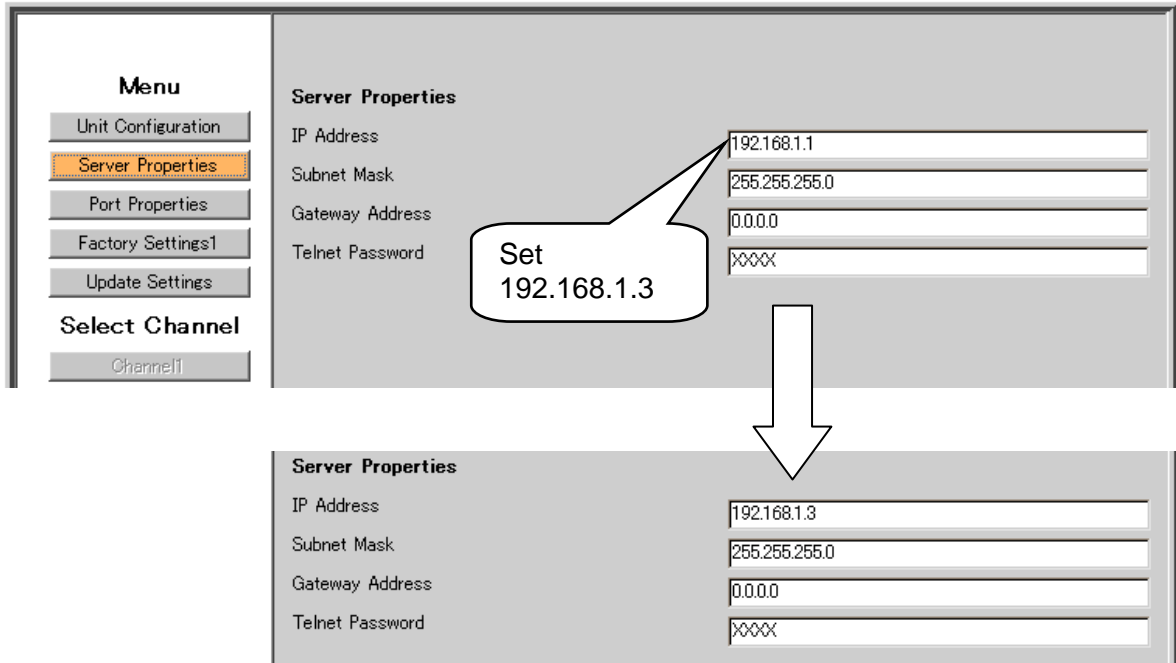

**Do not change the contents of “Selected Channel: 1.” If changed, device failure or error may result.**

3. Display the Server Properties screen.  
Set "192.168.1.3" in IP Address.



 **Do not change any items other than the IP Address. If so, device failure or error may result.**

4. Clicking the **Update Settings** button on the Menu display updates the setting to display the following message.

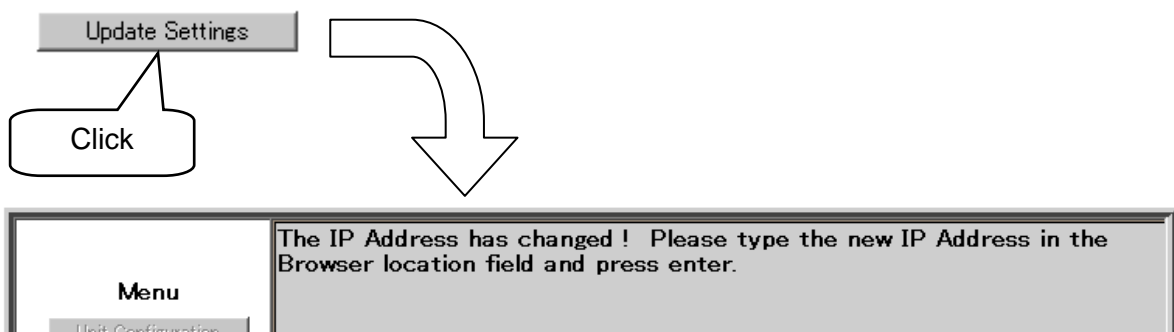

5. Enter the new IP address "192.168.1.3" into the address bar as instructed by message and then press the Enter key. Thus, a new IP address setting screen appears to end the setting.



---

## 6.2 Setting by Telnet

Set the IP address by the software “Telnet” attached to Windows.

### ■ Preparations before setting

When setting the IP address by Telnet, it is necessary to coincide the 1st to 3rd bytes and masking range of the IP address of the client (computer) which starts Telnet with those of the IP address of the COM-JL.

1. Connect the COM-JL and client, and then turn on the power.

 For wiring procedure, see **4. WIRING (P. 8)**.

2. Change the IP address of the client.

The IP address of the COM-JL is set to a factory set value of “192.168.1.1.” As it is necessary to coincide the 1st to 3rd byte values of this IP address with those of the IP address of the client.

Setting value: 192.168.1.  ( : Any value in the range of 0 to 255, but other than 1)

3. Change the subnet mask of the client.

As the subnet mask of the COM-JL is “255.255.255.0,” also change the subnet mask of the client.

Setting value: 255.255.255.0



After the IP address of the server is set, return the present IP address of the client to the original address or change to the address meeting the network to be connected.



It is possible to set the IP address of the COM-JL using the client already connected to the network. **However, as the IP address of the client is changed, that client is disconnected from the network so far connected.**

In addition, when setting the IP address by this method, confirm to the network administrator whether or not no problem arises.

## ■ Setting example

An example of setting the IP address of the COM-JL to “192.168.1.3” is shown in the following.

1. Display the MS-DOS prompt (command prompt); enter the following command and then press the Enter key. (Description below is example when Windows is C drive.)

```
C:¥>telnet 192.168.1.1 9999
```

2. Device information on the module (COM-JL) whose IP address is “192.168.1.1” is displayed. Finally, as the message “Press Enter to go into Setup Mode” is displayed, press the Enter key to go into Setup Mode.

```
MAC address 00204A8064BD
Software version 01.3 (030612) XPTE

Press Enter to go into Setup Mode
```



If the timing of pressing the Enter key is late, the message “Connection with Host was cut off” is displayed and thus the client is disconnected from the COM-JL. Therefore if the message “Press Enter to go into Setup Mode” is displayed, immediately press the Enter key. If disconnected, try again from “I. .”

3. If entered into Setup Mode, the present Ethernet information is displayed. Finally, eight choices are displayed as “Change Setup:.” Therefore enter “0” after “Your choice ?” and then press the Enter key.

```
*** basic parameters
Hardware: Ethernet TPI
IP addr 192.168.1.1, no gateway set,netmask 255.255.255.000

***** Security *****
SNMP is          enabled
SNMP Community Name: public
Telnet Setup is  enabled
TFTP Download is enabled
Port 77FEh is    enabled
Web Server is    enabled
ECHO is          disabled
Enhanced Password is disabled

***** Channel 1 *****
Baudrate 38400, I/F Mode 7C, Flow 00
Port 00502
Remote IP Adr: --- none ---, Port 00000
Connect Mode: C0   Disconn Mode: 00
Flush Mode: 80
Pack Cntrl   : 00
```

Continued on the next page.

Continued from the previous page.

```
***** Expert *****
TCP Keepalive      : 45s
ARP cache timeout: 600s

***** E-mail *****
Mail server: 0.0.0.0
Unit          :
Domain       :
Recipient 1:
Recipient 2:

*** Trigger 1
Serial Sequence: 00,00
CP1: X
CP2: X
CP3: X
Message:
Priority : L
Min. notification interval: 1 s
Re-notification interval : 0 s

*** Trigger 2
Serial Sequence: 00,00
CP1: X
CP2: X
CP3: X
Message:
Priority : L
Min. notification interval: 1 s
Re-notification interval : 0 s

*** Trigger 3
Serial Sequence: 00,00
CP1: X
CP2: X
CP3: X
Message:
Priority : L
Min. notification interval: 1 s
Re-notification interval : 0 s

Change Setup:
 0 Server configuration
 1 Channel 1 configuration
 3 E-mail settings
 5 Expert settings
 6 Security
 7 Factory defaults
 8 Exit without save
 9 Save and exit

Your choice ? 0
```

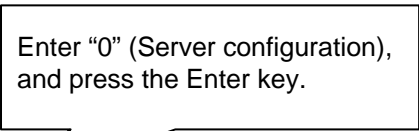

4. Selecting “0: Server configuration” makes ready to set the IP address.

Enter the IP address one byte by one byte.

As the following display appears, enter “192” into the first byte and then press the Enter key.

```
IP Address : (192) 192
```

Next, enter “168” into the second byte and then press the Enter key.

```
IP Address : (192) 192.(168) 168
```

Enter “1” into the third byte and then press the Enter key.

```
IP Address : (192) 192.(168) 168.(001) 1
```

Enter “3” into the fourth byte and then press the Enter key.

```
IP Address : (192) 192.(168) 168.(001) 1.(001) 3
```

5. After the IP address is entered, the following display appears. Therefore press the Enter key to proceed to the next.

```
IP Address : (192) 192.(168) 168.(001) 1.(001) 3
Set Gateway IP Address (N) N
```

In addition, as one line is displayed, press the Enter key to proceed to the next.

```
IP Address : (192) 192.(168) 168.(001) 1.(001) 3
Set Gateway IP Address (N) N
Netmask: Number of Bits for Host Part (0=default) (16)
```

Further, as more one line is displayed, press the Enter key to proceed to the next.

```
IP Address : (192) 192.(168) 168.(001) 1.(001) 3
Set Gateway IP Address (N) N
Netmask: Number of Bits for Host Part (0=default) (16)
Change telnet config password (N) N
```

6. As “Change Setup:” is displayed again, enter “9” after “Your choice ?” and then press the Enter key.

<p>Change Setup: 0 Server configuration 1 Channel 1 configuration 3 E-mail settings 5 Expert settings 6 Security 7 Factory defaults 8 Exit without save 9 Save and exit</p>	<p>Your choice ? 9</p>	<p>Enter “9” (Save and exit), and press the Enter key.</p>
---	------------------------	--

7. “Parameters stored ...” is displayed and thus the setting is finished.

<p>Parameters stored ...</p> <p>Connection with Host was cut off</p>
--

## 6.3 Setting by DeviceInstaller

Use the special tool DeviceInstaller to configure IP address and TCP port settings.

DeviceInstaller can be downloaded from the Web site of Lantronix Inc..

For the detailed setting procedures, see the documentation attached to the DeviceInstaller.



Before DeviceInstaller can be used, Microsoft's “.NET Framework” must be installed. “.NET Framework” can be downloaded from Microsoft's Web site.

### ■ Setting outline

1. Connect the COM-JL and client, and then turn on the power.



For wiring procedure, see **4. WIRING (P. 8)**.

2. Start the DeviceInstaller, and click the “Assign IP” icon.

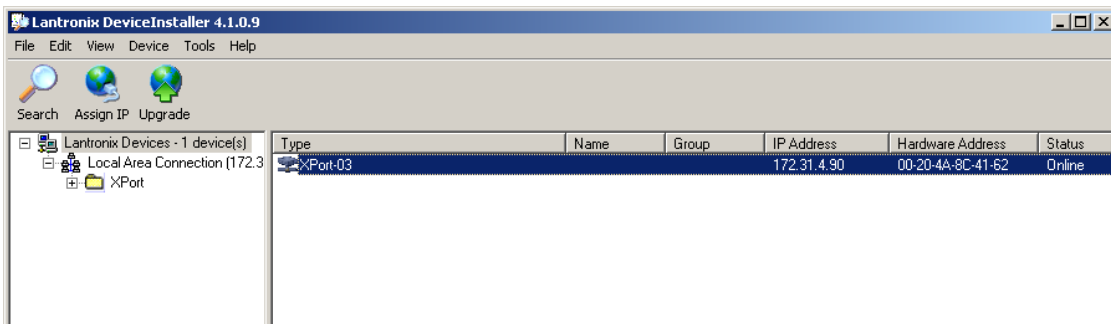

3. Select the “Assign a specific IP address”, and click the “Next >” button.

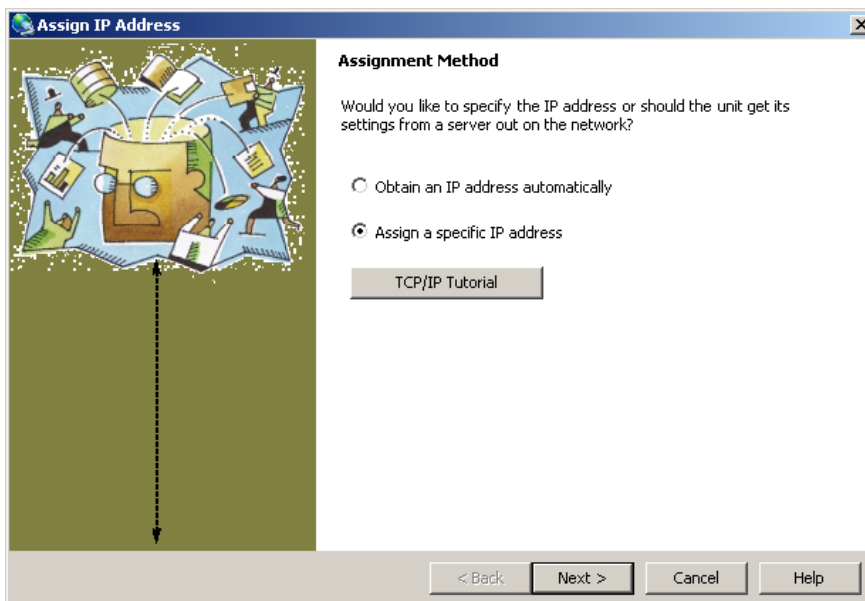



4. Enter the IP address, and click “Next >” button.

 Check that the subnet mask value is “255.255.255.0”.

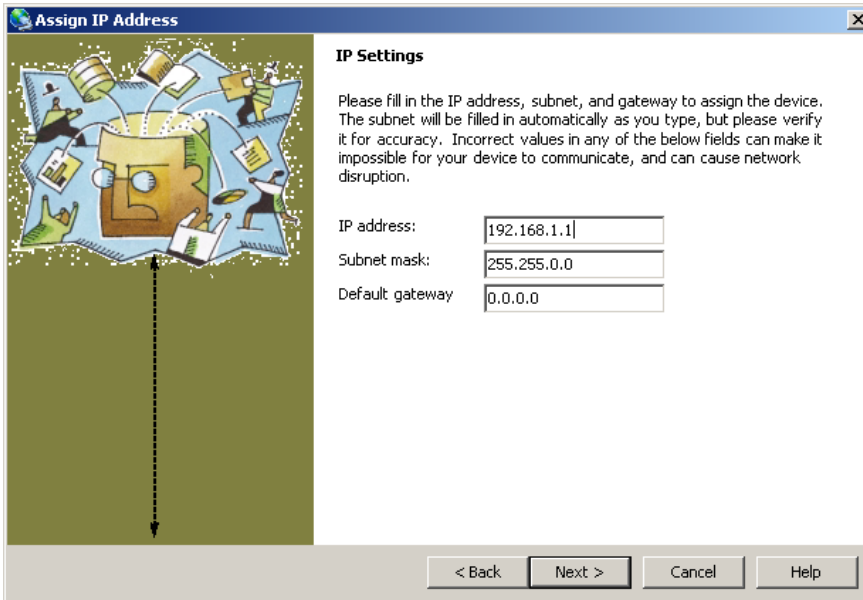

The screenshot shows the 'Assign IP Address' dialog box with the 'IP Settings' tab selected. The dialog contains a large illustration of a puzzle piece with a face on the left. To the right, there is a text box with instructions: 'Please fill in the IP address, subnet, and gateway to assign the device. The subnet will be filled in automatically as you type, but please verify it for accuracy. Incorrect values in any of the below fields can make it impossible for your device to communicate, and can cause network disruption.' Below this are three input fields: 'IP address' with '192.168.1.1', 'Subnet mask' with '255.255.0.0', and 'Default gateway' with '0.0.0.0'. At the bottom, there are four buttons: '< Back', 'Next >', 'Cancel', and 'Help'.

5. Click the “Assign” button to set the IP address.

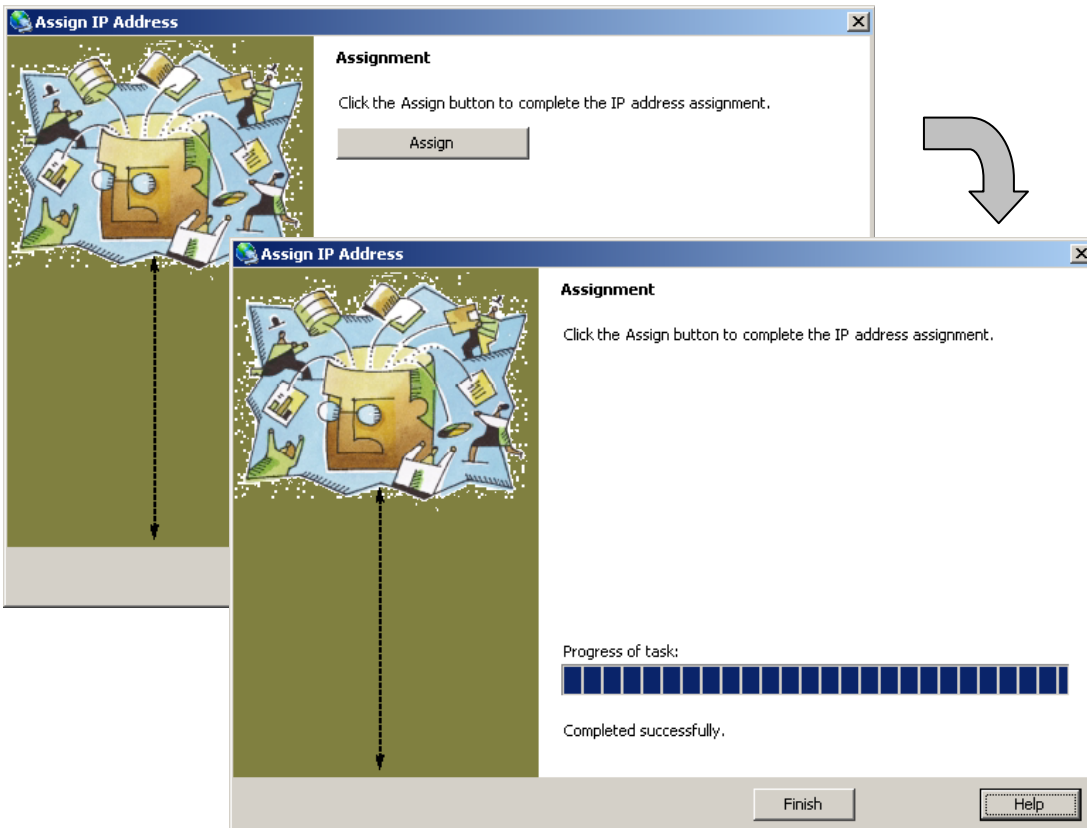

The first screenshot shows the 'Assign IP Address' dialog box with the 'Assignment' tab selected. The text says 'Click the Assign button to complete the IP address assignment.' and there is an 'Assign' button. A large grey arrow points from this dialog to the second screenshot below it. The second screenshot shows the same dialog box after the 'Assign' button has been clicked. The text now says 'Click the Assign button to complete the IP address assignment.' Below this is a progress bar labeled 'Progress of task:' which is filled with 15 blue segments. Below the progress bar, it says 'Completed successfully.' At the bottom, there are two buttons: 'Finish' and 'Help'.

## 6.4 Setting by the DIP Switch

It is possible to set the IP address by DIP switch with Ethernet not connected.

DIP switches used are “DIP switch 1” and “DIP switch 2” on the left side of the module.

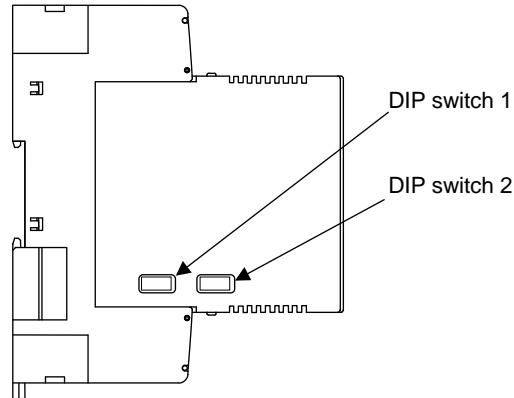

Left side view of COM-JL



Factory set value of an IP address of a COM-JL is “192.168.1.1.”

### ■ Setting example

An example of setting the IP address of the COM-JL to “192.168.1.3” is shown in the following.

#### 1. Setting preparations

Turn on No. 6 and off No. 7 of DIP switch 1 with the power turned off.

It does not matter whether Nos. 1 to 5 and No. 8 of DIP switch 1 is turned on or off.

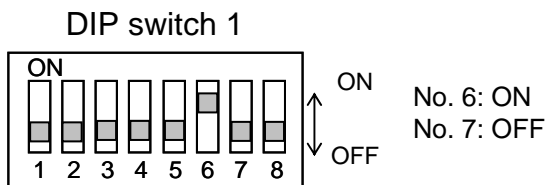

#### 2. Power ON

Turning the power on goes to IP address setup mode. Thus, the FAIL lamp lights.

In addition, the first byte (most significant byte) of the IP address is set to the entry wait state.

(RUN lamp: ON, TX lamp: ON, RX lamp: OFF)

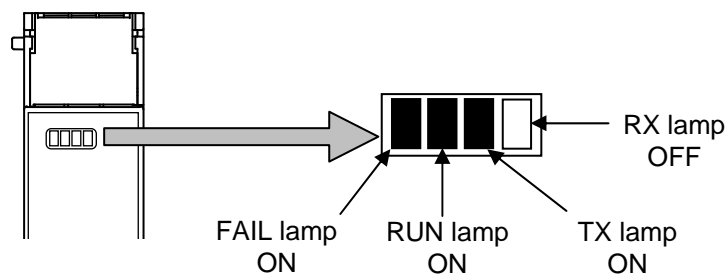

### 3. Input the first byte “192”

Enter the first byte (most significant byte) by DIP switch 2. As the first byte (most significant byte) is entered with “192,” this number corresponds to a binary number of “11000000.” Conduct the following setting with No. 8 of DIP switch 2 set to the most significant bit.

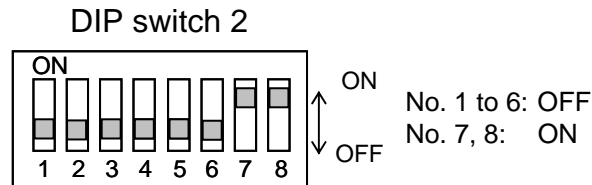

### 4. Decision of the first byte input

In order to establish the setting of DIP switch 2, turn off No. 6 of DIP switch 1.

In addition, the second byte of IP address is set to the entry wait state.

(RUN lamp: ON, TX lamp: OFF, RX lamp: OFF)

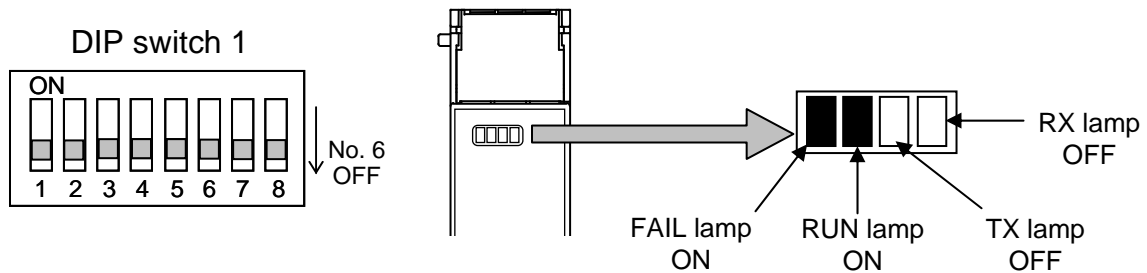

### 5. Input the second byte “168”

Enter the second byte by DIP switch 2. As the second byte is entered with “168,” this number corresponds to a binary number of “10101000.” Conduct the following setting with No. 8 of DIP switch 2 set to the most significant bit.

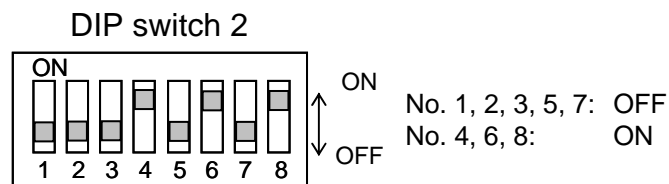

### 6. Decision of the second byte input

In order to establish the setting of DIP switch 2, turn on No. 6 of DIP switch 1.

In addition, the third byte of IP address is set to the entry wait state.

(RUN lamp: OFF, TX lamp: ON, RX lamp: OFF)

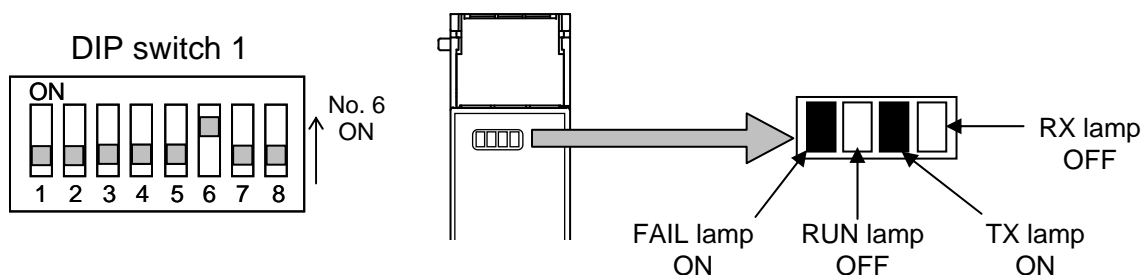

**7. Input the third byte “1”**

Enter the third byte by DIP switch 2. As the third byte is entered with “1,” this number corresponds to a binary number of “00000001.” Conduct the following setting with No. 8 of DIP switch 2 set to the most significant bit.

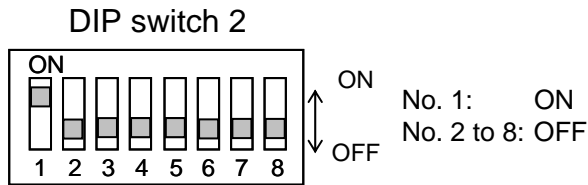

**8. Decision of the third byte input**

In order to establish the setting of DIP switch 2, turn off No. 6 of DIP switch 1. In addition, the fourth byte of IP address is set to the entry wait state. (RUN lamp: OFF, TX lamp: OFF, RX lamp: OFF)

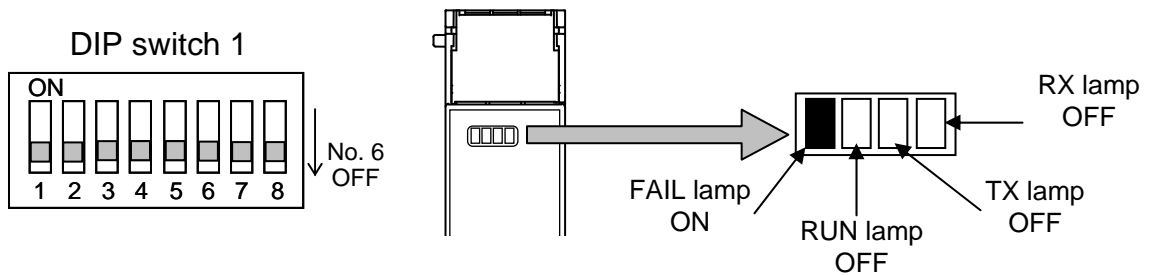

**9. Input the fourth byte “3”**

Enter the fourth byte by DIP switch 2. As the fourth byte is entered with “3,” this number corresponds to a binary number of “00000011.” Conduct the following setting with No. 8 of DIP switch 2 set to the most significant bit.

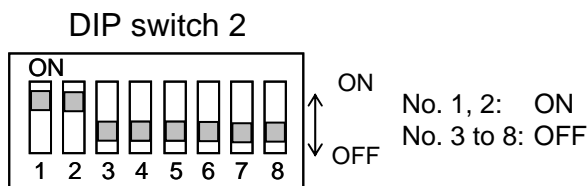

**10. Decision of the fourth byte input**

In order to establish the setting of DIP switch 2, turn on No. 6 of DIP switch 1. Thus, the IP address setting is finished and the FAIL lamp goes off. (RUN lamp: OFF, TX lamp: OFF, RX lamp: OFF)

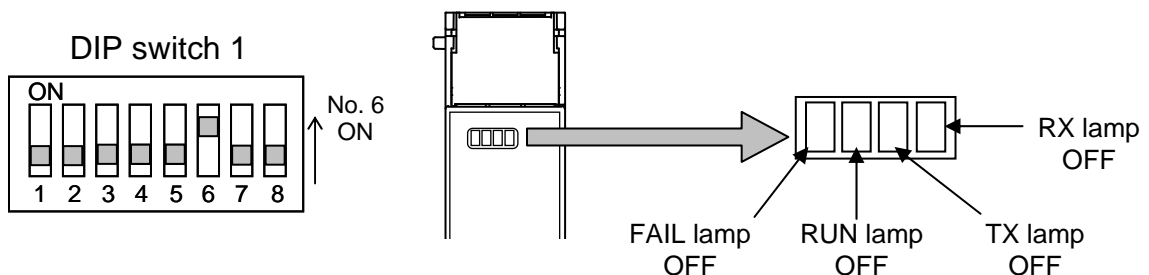

### 11. Decision of the IP address

After a lapse of a few seconds, the RUN lamp lights and the IP address is established.

The FAIL, TX and RX lamps flash until the IP address is established and they go off after the IP address is established.

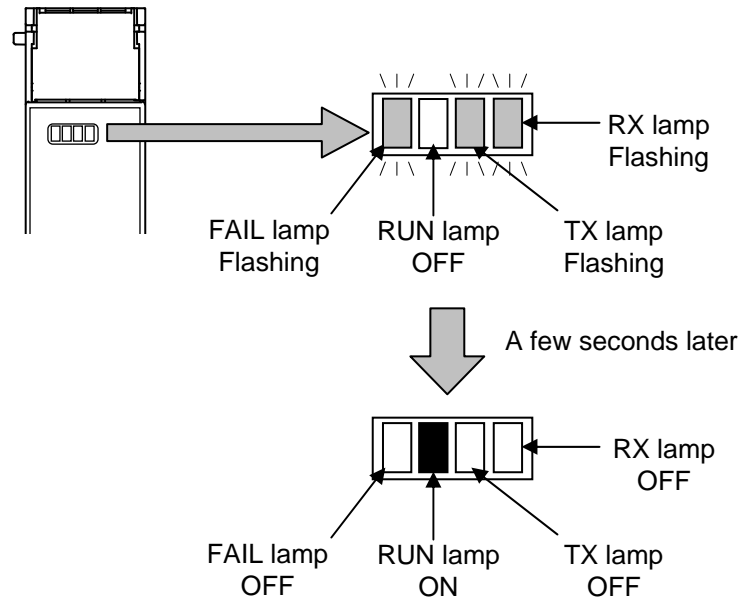

### 12. Power OFF

Turn the power off and also turn off No. 6 of DIP switch 1. In addition, turn off all Nos. of DIP switch 2.

If the power is turned on, operation starts at the IP address thus set.

# 7. MODBUS/TCP PROTOCOL

Modbus/TCP is an open field network provided with the Modbus protocol on the TCP/IP protocol of Ethernet.

The data request side is called “client” (such as computer) and the data response (supply) side is called “server” (COM-JL).

## 7.1 Message Configuration

Modbus ADU (Application Data Unit) on TCP/IP is in the following configuration.

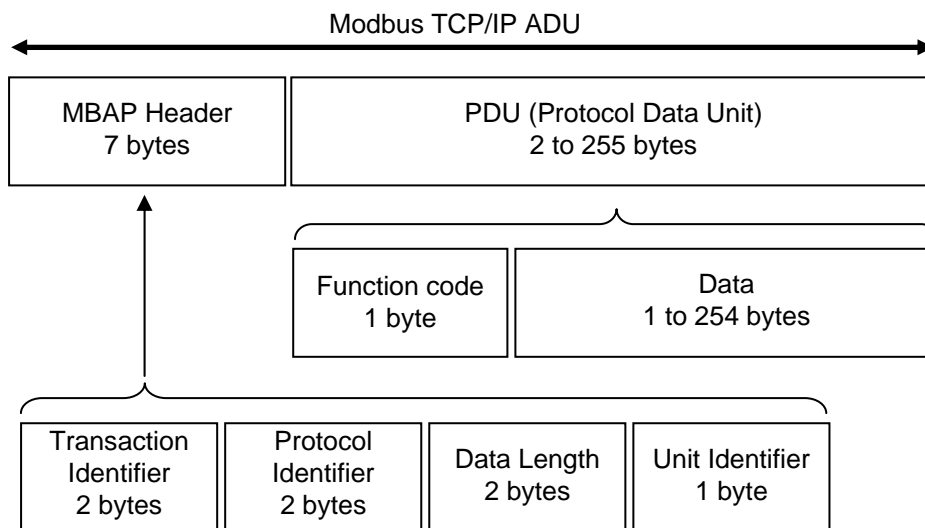

### ■ MBAP Header

MBAP (Modbus Application Protocol) header contains the following fields: Transaction Identifier, Protocol Identifier, Data Length and Unit Identifier.

Fields	Length	Request (Client)	Response (Server)
Transaction Identifier	2 bytes	Unused However, data corresponding to two bytes is sent According to need, request and the response are used in order to take consistency	Returns data from the client as is
Protocol Identifier	2 bytes	“0” fixed (Modbus protocol = 0)	Returns data from the client as is
Data Length	2 bytes	The total number of bytes of Unit Identifier and PDU (256 bytes max.)	The total number of bytes of Unit Identifier and PDU (256 bytes max.)
Unit Identifier	1 byte	Unused However, data corresponding to one byte is sent According to need, request and the response are used in order to take consistency	Returns data from the client as is

## ■ PDU

PDU (Protocol Data Unit) consists of two blocks: function codes and data.

Fields	Length	Request (Client)	Response (Server)
Function code	1 byte	03H: Read holding registers 06H: Write single register 08H: Diagnostics (loopback test) 10H: Write multiple registers 17H: Read/write multiple registers	Normal response Returns data from the client as is Error response 80H + Function code
Data	1 to 254 bytes	Data meeting the function code	Normal response Data meeting the function code Error response Exception code 01H: Illegal function code 02H: Illegal register address 03H: Illegal data value 04H: Server failure 06H: Server busy

## 7.2 Function Code

### ● Function code contents

Function code	Function	Contents
03H	Read holding registers	Measured value, Control output value, Current transformer input value, Event status, etc.
06H	Write single register	Set value, PID constants, Event set value, etc.
08H	Diagnostics (loopback test)	Loopback test
10H	Write multiple registers	Set value, PID constants, Event set value, etc.
17H	Read/write multiple registers	Measured value, Control output value, Current transformer input value, Event status, Set value, PID constants, Event set value, etc.

### ● Message (PDU) length of each function [Unit: byte]

Function code	Function	Request message		Response message	
		Min	Max	Min	Max
03H	Read holding registers	5	5	4	252
06H	Write single register	5	5	5	5
08H	Diagnostics (loopback test)	5	5	5	5
10H	Write multiple registers	8	252	5	5
17H	Read/write multiple registers	12	246	4	238

## 7.3 Server (COM-JL) Responses

### ■ Normal response

- In the response message of the read holding registers, the server (COM-JL) returns the “Function code,” “Number of data items” and the “Read out data” as the response message.
- In the response message of the write single register and diagnostics (loopback test), the server (COM-JL) returns the same message as the request message.
- In the response message of the write multiple registers, the server (COM-JL) returns the “Function code,” the “Register address number” and the “Number of register” as the response message.
- In the response message of the read/write multiple registers, the server (COM-JL) returns the “Function code,” “Number of write data items” and the “Read out data” as the response message.



### ■ Defective message response

- If the request message from the client is defective, except for transmission error, the server (COM-JL) returns the exception response message without any action.
- If the self-diagnostic function of the server (COM-JL) detects an error, the server will return an exception response message to all request messages.
- The function code of each exception response message is obtained by adding “80H” to the function code of the request message.

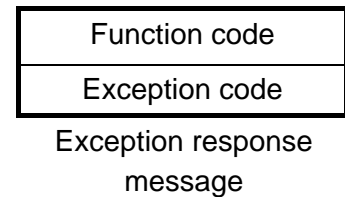

Exception code	Contents	Causes
01H	Illegal function code	An unsupported function code was specified
02H	Illegal register address	When the mismatched register address is specified.
03H	Illegal data value	<ul style="list-style-type: none"> <li>• The number of specified data points was out of the following range during data read or write. Function code 03H: 1 to 125 Function code 10H: 1 to 123 Function code 17H: 1 to 118</li> <li>• When the data written exceeds the setting range</li> </ul>
04H	Server failure	State under which the server cannot normally respond (An error occurred in the server)
06H	Server busy	State under which the server cannot immediately respond (The server is being initialized)

Exception code priority order

01H > 03H > 02H > 04H > 06H

- Order of a no response in PDU data length error  
When Specified PDU data length < Received PDU data length:  
01H > No response in PDU data length error > 03H  
When Specified PDU data length > Received PDU data length:  
No response in PDU data length error > 01H
- Order when reading/writing the register contents  
When there is 02H or 03H only for read processing:  
01H > 04H > 06H > 03H > 02H
- Order when out of the setting range  
For 03H when out of the setting range: 01H > 02H > 04H > 06H > 03H

### ■ No response

The server (COM-JL) ignores the request message and does not respond when:

- The IP address does not coincide.
- The server (COM-JL) is not connected to the network.
- The PDU (Protocol Data Unit) data length is abnormal.  
When the PDU data length specified by the request message does not coincide with the number of bytes received as one TCP packet.  
COM-JL determines whether or not communication messages correspond to one packet by time-out (approx. 12 ms) between characters.

## 7.4 Message Format

### 7.4.1 Read holding registers [03H]

The request message specifies the starting register address number and quantity of register addresses to be read.

The contents of the registers are entered in the response message as data, divided into two parts: the high-order eight bits and low-order eight bits, arranged in the order of the register numbers.

**Example: The contents of the four registers from 0000H to 0003H are the read out.**

#### Request message [Client]

Transaction Identifier	High	00H	} MBAP Header	
	Low	00H		
Protocol Identifier	High	00H		
	Low	00H		
Data Length	High	00H		
	Low	06H		
Unit Identifier		00H		
Function code		03H		
Register address	High	00H		} First register address
	Low	00H		
Quantity (Number of words)	High	00H	} The setting must be between 1 (0001H) and 125 (007DH).	
	Low	04H		

#### Normal response message [Server]

Transaction Identifier	High	00H	} MBAP Header	
	Low	00H		
Protocol Identifier	High	00H		
	Low	00H		
Data Length	High	00H		
	Low	0BH		
Unit Identifier		00H		
Function code		03H		
Number of data (byte)		08H		→ Number of registers × 2
First register contents	High	01H		
	Low	24H		
Next register contents	High	01H		
	Low	1BH		
Next register contents	High	01H		
	Low	2BH		
Next register contents	High	01H		
	Low	22H		

**Exception response message [Sever]**

Transaction Identifier	High	00H
	Low	00H
Protocol Identifier	High	00H
	Low	00H
Data Length	High	00H
	Low	03H
Unit Identifier		00H
80H + Function code		83H
Exception code		03H

MBAP Header

→ When the data exceeds the setting range

## 7.4.2 Write single register [06H]

The request message specifies data to be written into the designated register.

Write data items are arranged in the request message in order starting from the smallest register address number. In addition, each register address is assigned in the order of high-order eight bits and low-order eight bits, respectively.

**Example: When 100 (64H) is written to the register 0B00H**

### Request message [Client]

Transaction Identifier	High	00H	} MBAP Header	
	Low	00H		
Protocol Identifier	High	00H		
	Low	00H		
Data Length	High	00H		
	Low	06H		
Unit Identifier		00H		
Function code		06H		
Register address	High	0BH		} Any data within the range
	Low	00H		
Write data	High	00H		
	Low	64H		

### Normal response message [Server]

Transaction Identifier	High	00H	} Contents will be the same as request message data
	Low	00H	
Protocol Identifier	High	00H	
	Low	00H	
Data Length	High	00H	
	Low	06H	
Unit Identifier		00H	
Function code		06H	
Register address	High	0BH	
	Low	00H	
Write data	High	00H	
	Low	64H	

### Exception response message [Server]

Transaction Identifier	High	00H	} MBAP Header	
	Low	00H		
Protocol Identifier	High	00H		
	Low	00H		
Data Length	High	00H		
	Low	03H		
Unit Identifier		00H		
80H + Function code		86H		
Exception code		03H		→ When the data exceeds the setting range

### 7.4.3 Diagnostics (Loopback test) [08H]

The client's request message will be returned as the response message from the server.  
This function checks the communication system between the client and server (COM-JL).

#### Example: Loopback test

##### Request message [Client]

Transaction Identifier	High	00H	} MBAP Header
	Low	00H	
Protocol Identifier	High	00H	
	Low	00H	
Data Length	High	00H	
	Low	06H	
Unit Identifier		00H	
Function code		08H	
Test code	High	00H	
	Low	00H	
Data	High	1FH	} Any pertinent data
	Low	34H	

##### Normal response message [Server]

Transaction Identifier	High	00H	} Contents will be the same as request message data
	Low	00H	
Protocol Identifier	High	00H	
	Low	00H	
Data Length	High	00H	
	Low	06H	
Unit Identifier		00H	
Function code		08H	
Test code	High	00H	
	Low	00H	
Data	High	1FH	
	Low	34H	

##### Exception response message [Server]

Transaction Identifier	High	00H	} MBAP Header
	Low	00H	
Protocol Identifier	High	00H	
	Low	00H	
Data Length	High	00H	
	Low	03H	
Unit Identifier		00H	
80H + Function code		88H	
Exception code		06H	→ When server is busy

### 7.4.4 Write multiple registers [10H]

Each data is written to registers in specified quantities starting from the specified register address. Write data items are arranged in the request message in order starting from the smallest register address number. In addition, each register address is assigned in the order of high-order eight bits and low-order eight bits, respectively.

**Example: When 100 (64H) and 120 (78H) are written to the register 0B00H and 0B01H (two in total)**

#### Request message [Client]

Transaction Identifier	High	00H	} MBAP Header	
	Low	00H		
Protocol Identifier	High	00H		
	Low	00H		
Data Length	High	00H		
	Low	0BH		
Unit Identifier		00H		
Function code		10H		
Register address	High	0BH		} First register address
	Low	00H		
Quantity (Number of words)	High	00H	} The setting must be between 1 (0001H) and 123 (007BH).	
	Low	02H		
Number of data (byte)		04H	→ Number of registers × 2	
Data to first register	High	00H		
	Low	64H		
Data to next register	High	00H		
	Low	78H		

#### Normal response message [Server]

Transaction Identifier	High	00H	} MBAP Header	
	Low	00H		
Protocol Identifier	High	00H		
	Low	00H		
Data Length	High	00H		
	Low	06H		
Unit Identifier		00H		
Function code		10H		
Register address	High	0BH		} First register address
	Low	00H		
Quantity (Number of words)	High	00H		
	Low	02H		

**Exception response message [Sever]**

Transaction Identifier	High	00H
	Low	00H
Protocol Identifier	High	00H
	Low	00H
Data Length	High	00H
	Low	03H
Unit Identifier		00H
80H + Function code		90H
Exception code		03H

MBAP Header

→ When the data exceeds the setting range

### 7.4.5 Read/write multiple registers [17H]

The contents of consecutive registers in specified quantities are read starting from the specified register address. Each data is written to registers in specified quantities starting from the specified register address.

**Example:** When data is read from the register 0000H (one in total) and then 100 (64H) and 120 (78H) are written to the register 0B00H and 0B01H (two in total)

#### Request message [Client]

Transaction Identifier	High	00H	} MBAP Header	
	Low	00H		
Protocol Identifier	High	00H		
	Low	00H		
Data Length	High	00H		
	Low	0FH		
Unit Identifier		00H		
Function code		17H		
Read register address	High	00H		} First read register address
	Low	00H		
Read quantity (Number of words)	High	00H	} The setting must be between 1 (0001H) and 118 (0076H).	
	Low	01H		
Write register address	High	0BH	} First write register address	
	Low	00H		
Write quantity (Number of words)	High	00H	} The setting must be between 1 (0001H) and 118 (0076H).	
	Low	02H		
Number of write data (byte)		04H	→ Number of write registers × 2	
Written data to first register	High	00H	} MBAP Header	
	Low	64H		
Written data to next register	High	00H		
	Low	78H		

#### Normal response message [Server]

Transaction Identifier	High	00H	} MBAP Header	
	Low	00H		
Protocol Identifier	High	00H		
	Low	00H		
Data Length	High	00H		
	Low	05H		
Unit Identifier		00H		
Function code		17H		
Number of write data (byte)		04H		→ Number of write registers × 2
Read register contents	High	00H		} MBAP Header
	Low	6EH		



**Exception response message [Sever]**

Transaction Identifier	High	00H
	Low	00H
Protocol Identifier	High	00H
	Low	00H
Data Length	High	00H
	Low	03H
Unit Identifier		00H
80H + Function code		97H
Exception code		03H

MBAP Header

→ When the data exceeds the setting range

## 7.5 Data Configuration

### 7.5.1 Data scale

The numeric range of data used in this protocol is 0000H to FFFFH. Only the set value within the setting range is effective.



FFFFH represents -1.

#### ■ Data processing with decimal points

The Modbus/TCP protocol does not recognize data with decimal points during communication.

#### ● Data without decimal points

[Data of Z-TIO module]

Comprehensive event state	Startup tuning (ST)	Heater break alarm (HBA) type
Operation mode state monitor	Automatic temperature rise learning	Number of heater break alarm (HBA) delay times
Error code	Communication switch for logic	Hot/Cold start
Burnout state monitor	Input type	SV tracking
Event 1 state monitor	Display unit	MV transfer function
Event 2 state monitor	Decimal point position	Control action
Event 3 state monitor	Burnout direction	Integral/derivative time decimal point position
Event 4 state monitor	Square root extraction	Derivative action
Heater break alarm (HBA) state monitor	Output assignment selection	Action (high) at input error
Output state monitor	Energized/De-energized	Action (low) at input error
Memory area soak time monitor	Event 1 type	AT cycles
Integrated operating time monitor	Event 1 channel setting	Action at feedback resistance (FBR) input error
Backup memory state monitor	Event 1 hold action	Feedback adjustment
Logic output monitor	Event 1 interlock	Control motor time
PID/AT transfer	Event 1 delay timer	Valve action at STOP
Auto/Manual transfer	Force ON of Event 1 action	ST start condition
Remote/Local transfer	Event 2 type	Automatic temperature rise group
RUN/STOP transfer	Event 2 channel setting	EDS transfer time decimal point position
Memory area transfer	Event 2 hold action	Setting change rate limiter unit time
Interlock release	Event 2 interlock	Soak time unit
Control loop break alarm (LBA) time	Event 2 delay timer	PV transfer function
Control response parameter	Force ON of Event 2 action	Operation mode assignment *
Area soak time	Event 3 type	SV select function
Link area number	Event 3 channel setting	Remote SV function master channel module address
Output distribution selection	Event 3 hold action	Remote SV function master channel selection
Minimum ON/OFF time of proportioning cycle	Event 3 interlock	Output distribution master channel module address
Area soak time stop function	Event 3 delay timer	Output distribution master channel selection
EDS mode (for disturbance 1)	Force ON of Event 3 action	Address of interacting module
EDS mode (for disturbance 2)	Event 4 type	Channel selection of interacting modules
EDS action time (for disturbance 1)	Event 4 channel setting	Selection switch of interacting modules
EDS action time (for disturbance 2)	Event 4 hold action	Control RUN/STOP holding setting
EDS value learning times	Event 4 interlock	Interval time
EDS start signal	Event 4 delay timer	
Operation mode	Force ON of Event 4 action	
	CT ratio	
	CT assignment	

**[Data of Z-DIO module]**

Digital input (DI) state	Memory area setting signal
Digital output (DO) state	DO signal assignment module address 1
Error code	DO signal assignment module address 2
Integrated operating time monitor	DO output assignment 1 [DO1 to DO4]
Backup memory state monitor	DO output assignment 2 [DO5 to DO8]
RUN/STOP transfer	DO energized/de-energized
DO manual output	DO output distribution master channel module address
DO output distribution selection	DO output distribution master channel selection
DO minimum ON/OFF time of proportioning cycle	Control RUN/STOP holding setting
DI function assignment	Interval time

Example: When Integrated operating time monitor is 72 hour,  
72 = 0048H

Integrated operating time monitor	High	00H
	Low	48H

- **Data with one decimal place**

**[Data of Z-TIO module]**

Manipulated output value (MV) monitor [heat-side]	Manipulated output value at input error
Manipulated output value (MV) monitor [cool-side]	Manipulated output value at STOP mode [heat-side]
Current transformer (CT) input value monitor	Manipulated output value at STOP mode [cool-side]
Holding peak value ambient temperature monitor	Output change rate limiter (up) [heat-side]
Manual reset	Output change rate limiter (down) [heat-side]
Heater break alarm (HBA) set value	Output limiter (high)[heat-side]
Heater break determination point	Output limiter (low)[heat-side]
Heater melting determination point	Output change rate limiter (up) [cool-side]
PV digital filter	Output change rate limiter (down) [cool-side]
RS digital filter	Output limiter (high) [cool-side]
Output distribution bias	Output limiter (low) [cool-side]
Proportional cycle time	Output value with AT turned on
Manual manipulated output value	Output value with AT turned off
EDS value 1 (for disturbance 1)	AT differential gap time
EDS value 1 (for disturbance 2)	Open/Close output neutral zone
EDS value 2 (for disturbance 1)	Integrated output limiter
EDS value 2 (for disturbance 2)	Automatic temperature rise dead time
EDS action time (for disturbance 1)	Automatic temperature rise group
EDS action time (for disturbance 2)	Output average processing time for EDS
Derivative gain	

**[Data of Z-DIO module]**

DO output distribution bias	DO output limiter (high)
DO proportioning cycle time	DO output limiter (low)
DO manipulated output value (MV) at STOP mode	

Example: When heater break alarm (HBA) set value 1 is 20.0 A, 20.0 is processed as 200,  
200 = 00C8H

Heater break alarm (HBA) set value	High	00H
	Low	C8H

● **Data with two decimal places**

[Data of Z-TIO module]

- |  |  |
|--|--|
| PV low input cut-off                           | Integral time adjusting factor [cool-side]   |
| Proportional band adjusting factor [heat-side] | Derivative time adjusting factor [cool-side] |
| Integral time adjusting factor [heat-side]     | ST proportional band adjusting factor        |
| Derivative time adjusting factor [heat-side]   | ST integral time adjusting factor            |
| Proportional band adjusting factor [cool-side] | ST derivative time adjusting factor          |

Example: When PV low input cut-off is 0.55 second, 0.55 is processed as 55, 55 = 0037H

PV low input cut-off	High	00H
	Low	37H

● **Data with three decimal places**

[Data of Z-TIO module]

- |          |                               |
|----------|-------------------------------|
| PV ratio | Output distribution ratio     |
| RS ratio | Undershoot suppression factor |

[Data of Z-DIO module]

- DO output distribution ratio

Example: When PV ratio is 0.555, 0.555 is processed as 555, 555 = 022BH

PV ratio	High	02H
	Low	2BH

● **Data whose decimal point's presence and/or position depends on integral/derivative time decimal point position selection [Z-TIO module]**

The position of the decimal point changes depending on the integral/derivative time decimal point position selection type, because this protocol does not recognize data with decimal points during communication.

Type of decimal points position: No decimal place, one decimal place

- |  |  |
|--|--|
| Integral time [heat-side]                | Derivative time limiter (high) [heat-side] |
| Derivative time [heat-side]              | Derivative time limiter (low) [heat-side]  |
| Integral time [cool-side]                | Integral time limiter (high) [cool-side]   |
| Derivative time [cool-side]              | Integral time limiter (low) [cool-side]    |
| Integral time limiter (high) [heat-side] | Derivative time limiter (high) [cool-side] |
| Integral time limiter (low) [heat-side]  | Derivative time limiter (low) [cool-side]  |

Example: When Integral time [heat-side] is 240.0 seconds, 240.0 is processed as 2400, 2400 = 0960H

Integral time [heat-side]	High	09H
	Low	60H

● **Data whose decimal point's presence and/or position depends on EDS transfer time decimal point position selection [Z-TIO module]**

The position of the decimal point changes depending on the EDS transfer time decimal point position selection type, because the Modbus protocol does not recognize data with decimal points during communication.

Type of decimal points position: No decimal place, one decimal place

EDS transfer time (for disturbance 1)

EDS transfer time (for disturbance 2)

Example: When EDS transfer time (for disturbance 1) is 50.0 seconds, 50.0 is processed as 50, 500 = 01F4H

EDS transfer time (for disturbance 1)	High	01H
	Low	F4H

● **Data whose decimal point's presence and/or position depends on input range and decimal point position selection**

The position of the decimal point changes depending on the input range type and the decimal point position selection type, because this protocol does not recognize data with decimal points during communication.

Type of decimal points position:

Temperature input: No decimal place, one decimal place

Voltage/current input: No decimal place, one decimal place, two decimal places, three decimal places and four decimal places

Measured value (PV)	Setting change rate limiter (up)	Start determination point
Set value (SV) monitor	Setting change rate limiter (down)	ON/OFF action differential gap (upper)
Remote setting (RS) input value monitor	PV bias	ON/OFF action differential gap (lower)
Event 1 set value (EV1)	RS bias	AT bias
Event 2 set value (EV2)	Input scale high	Proportional band limiter (high) [heat-side]
Event 3 set value (EV3)	Input scale low	Proportional band limiter (low) [heat-side]
Event 4 set value (EV4)	Input error determination point (high)	Proportional band limiter (high) [cool-side]
LBA deadband	Input error determination point (low)	Proportional band limiter (low) [cool-side]
Set value (SV)	Event 1 differential gap	Responsive action trigger point for EDS
Proportional band [heat-side]	Event 2 differential gap	Setting limiter (high)
Proportional band [cool-side]	Event 3 differential gap	Setting limiter (low)
Overlap/Deadband	Event 4 differential gap	

Example: When Set value (SV) is  $-20.0^{\circ}\text{C}$ ,  $-20.0$  is processed as  $-200$ ,  $-200 = 0000\text{H} - 00\text{C}8\text{H} = \text{FF}38\text{H}$

Set value (SV)	High	FFH
	Low	38H

### 7.5.2 Caution for handling communication data

- In this communication, the variables that memory area includes handles different address with for control area and for setting area.
- If data (holding register) exceeding the accessible address range is accessed, an error response message is returned.
- Read data of unused item is a default value.
- Any attempt to write to an unused item is not processed as an error. Data can not be written into an unused item.
- If data range or address error occurs during data writing, it is not processed as an error. Except the data that error occurred, normal data is written in data register. Therefore, it is necessary to confirm data after the end of setting data.
- Communication data includes data that becomes RO (read only) depending on the specification. No error occurs even if data is written when set to RO. However in this case, no data is written.



For details, see **8. COMMUNICATION DATA LIST (P. 51)**.

### 7.5.3 How to use memory area data

Memory area function can store up to 8 individual sets of SVs and parameters. One of the areas is used for control, and the currently selected area is “Control area.”

Memory area data can be used to check and change settings that belong to memory areas other than the control area. Reading and writing of memory area data is performed by channel.

#### ■ Read and write of memory area data

If any memory area number to perform data read and write is specified by the setting memory area number (4000H to 403FH), data corresponding to the specified memory area number is called up to the register addresses from 4040H to 453FH. By using these register addresses from 4040H to 453FH, it becomes possible to read and write data in any memory area.

- Register address to specify memory area: 4000H to 403FH (Setting memory area number)
  - 4000H: Setting memory area number for channel 1 of controller (Z-TIO) address 1
  - 4001H: Setting memory area number for channel 2 of controller (Z-TIO) address 1
  - ⋮
  - 403FH: Setting memory area number for channel 4 of controller (Z-TIO) address 16
- Register address of memory area data: 4040H to 453FH
  - 4040H to 407FH: Event 1 set value
  - 4080H to 40BFH: Event 2 set value
  - 40C0H to 40FFH: Event 3 set value
  - 4100H to 413FH: Event 4 set value
  - 4140H to 417FH: Control loop break alarm (LBA) time
  - 4180H to 41BFH: LBA deadband
  - 41C0H to 41FFH: Set value (SV)
  - 4200H to 423FH: Proportional band [heat-side]
  - 4240H to 427FH: Integral time [heat-side]
  - 4280H to 42BFH: Derivative time [heat-side]
  - 42C0H to 42FFH: Control response parameter
  - 4300H to 433FH: Proportional band [cool-side]
  - 4340H to 437FH: Integral time [cool-side]
  - 4380H to 43BFH: Derivative time [cool-side]
  - 43C0H to 43FFH: Overlap/Deadband
  - 4400H to 443FH: Manual reset
  - 4440H to 447FH: Setting change rate limiter (up)
  - 4480H to 44BFH: Setting change rate limiter (down)
  - 44C0H to 44FFH: Area soak time
  - 4500H to 453FH: Link area number



Register address of each item corresponds to any channel 4 of controller address 16 from channel 1 of controller address 1.

### ■ Control area transfer

Any memory area used for control is specified by the memory area transfer (0900H to 093FH). The area (0980H to 0E7FH) now used for control is called “Control area.”

- Register address of memory area transfer: 0900H to 093FH
  - 0900H: Memory area transfer for channel 1 of controller (Z-TIO) address 1
  - 0901H: Memory area transfer for channel 2 of controller (Z-TIO) address 1
  - ⋮
  - 093FH: Memory area transfer for channel 4 of controller (Z-TIO) address 16
- Register address of control area data: 0980H to 0E7FH
  - 0980H to 09BFH: Event 1 set value
  - 09C0H to 09FFH: Event 2 set value
  - 0A00H to 0A3FH: Event 3 set value
  - 0A40H to 0A7FH: Event 4 set value
  - 0A80H to 0ABFH: Control loop break alarm (LBA) time
  - 0AC0H to 0AFFH: LBA deadband
  - 0B00H to 0B3FH: Set value (SV)
  - 0B40H to 0B7FH: Proportional band [heat-side]
  - 0B80H to 0BBFH: Integral time [heat-side]
  - 0BC0H to 0BFFH: Derivative time [heat-side]
  - 0C00H to 0C3FH: Control response parameter
  - 0C40H to 0C7FH: Proportional band [cool-side]
  - 0C80H to 0CBFH: Integral time [cool-side]
  - 0CC0H to 0CFFH: Derivative time [cool-side]
  - 0D00H to 0D3FH: Overlap/Deadband
  - 0D40H to 0D7FH: Manual reset
  - 0D80H to 0DBFH: Setting change rate limiter (up)
  - 0DC0H to 0DFH: Setting change rate limiter (down)
  - 0E00H to 0E3FH: Area soak time
  - 0E40H to 0E7FH: Link area number



Register address of each item corresponds to any channel 4 of controller address 16 from channel 1 of controller address 1.



# 8. COMMUNICATION DATA LIST

## 8.1 Reference to Communication Data List

No.	Name	Register address		Number of data items	Attribute	Data range	Factory set value
		HEX	DEC				
1	Measured value (PV)	0000	0	64	RO	Input scale low to Input scale high	—
2	Current transformer (CT) input value monitor	0040	64	64	RO	CTL-6-P-N: 0.0 to 30.0A CTL-12-S56-10L-N: 0.0 to 100.0 A	—
3	Unused	0080	128	64	—	—	—

**(1) Name:** Communication data name is written.

Symbol:

♣: Data for Z-DIO module

◆: Parameters only used for heat/cool control or position proportioning control, therefore data for CH2 and CH4 of Z-TIO module are unused.  
[Read: 0, Write: disregarded]

♥: Data for each module

**(2) Register address:** The register start number of each communication item (Vacant numbers becomes unused.)

HEX: Hexadecimal

DEC: Decimal

**(3) Number of data items:** Number of communication data items is written.

The address in the register address column will be the head address, and the number of data items is indicated in this column.

 In the case of two-channel type (Z-TIO-B modules), the number of the data per one module is the same as four-channel type (Z-TIO-A modules).

(4 channels × 16 modules = 64)

In addition, as for the Z-DIO module <sup>1</sup>, the number of the data per one module is 64.

(8 channels × 8 modules = 64)

<sup>1</sup> The ♣ mark of the name column is communication data of Z-DIO module.

**(4) Attribute:** A method of how communication data items are read or written when viewed from the host computer is described.

RO: Read only data  
 Host computer [Client] ← Data direction → Controller [Server]

R/W: Read and Write data  
 Host computer [Client] ↔ Data direction ↔ Controller [Server]

Continued on the next page.

Continued from the previous page.

**(5) Data range:** The reading range or the writing range of communication data is written.

 Bit image of bit data is as follows.

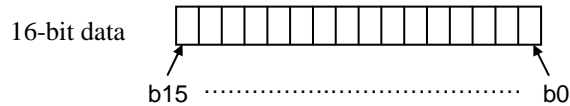

 With respect to the following communication data of the Z-TIO module, the data of the indicated channels are “Read data: 0” and “Write data: invalid”.

- Two-channel type module:  
Data of the 3rd and 4th channels
- Heat/cool control and position proportioning control:  
Data of the 2nd and 4th channels <sup>1</sup>
- Cool-only communication data of heat/cool control:  
Data of the 2nd and 4th channels <sup>1</sup>

<sup>1</sup> Communication data with a ♦ mark in the name column

 In the case of the communication data <sup>2</sup> corresponding to each module, as for the data of the module which is not connected, become to “Read data: 0” and “Write data: invalid”.

<sup>2</sup> Communication data with a ♥ mark in the name column

**(6) Factory set value:** The factory set value of communication data is written.

 **Communication includes both “Normal setting data” and “Engineering setting data”. During RUN (control), the attribute of engineering setting data is RO. To configure engineering setting data, the RUN/STOP switch must be set to STOP (control stopped).**

**Normal setting data: No. 1 to 82, 204, 210, 257 to 319**

**Engineering setting data: No. 83 to 203, 205 to 209, 211 to 256**

The Engineering setting data should be set according to the application before setting any parameter related to operation. Once the Engineering setting data are set correctly, those datas are not necessary to be changed for the same application under normal conditions. If they are changed unnecessarily, it may result in malfunction or failure of the instrument. RKC will not bear any responsibility for malfunction or failure as a result of improper changes in the Engineering setting.

 For the Memory area data, see **8.3 Memory area data items (P. 80)**.

 For details on the data, see **SRZ Instruction Manual (IMS01T04-E□)**.

## 8.2 SRZ (Z-TIO/Z-DIO module) Communication Data Items

No.	Name	Register address		Number of data items	Attribute	Data range	Factory set value
		HEX	DEC				
1	Measured value (PV)	0000	0	64	RO	Input scale low to Input scale high	—
2	Current transformer (CT) input value monitor	0040	64	64	RO	CTL-6-P-N: 0.0 to 30.0A CTL-12-S56-10L-N: 0.0 to 100.0 A	—
3	Unused	0080	128	64	—	—	—
4	Set value (SV) monitor	00C0	192	64	RO	Setting limiter (low) to Setting limiter (high)	—
5	Remote setting (RS) input value monitor	0100	256	64	RO	Setting limiter (low) to Setting limiter (high)	—
6	Burnout state monitor	0140	320	64	RO	0: OFF 1: ON	—
7	Unused	0180	384	64	—	—	—
8	Event 1 state monitor	01C0	448	64	RO	0: OFF 1: ON	—
9	Event 2 state monitor	0200	512	64	RO	If the Event 3 type is temperature rise completion, check the temperature rise completion state in the comprehensive event state (No. 25). (The Event 3 state monitor does not turn ON.)	—
10	Event 3 state monitor	0240	576	64	RO		—
11	Event 4 state monitor	0280	640	64	RO		—
12	Heater break alarm (HBA) state monitor	02C0	704	64	RO	0: OFF 1: ON	—
13	Unused	0300	768	64	—	—	—
14	Manipulated output value (MV) monitor [heat-side] ◆	0340	832	64	RO	PID control or heat/cool PID control: -5.0 to +105.0 % Position proportioning control with feedback resistance (FBR) input: 0.0 to 100.0 %	—
15	Manipulated output value (MV) monitor [cool-side] ◆	0380	896	64	RO	-5.0 to +105.0 %	—
16	Error code * ♥	03c0	960	64	RO	Bit data b0: Adjustment data error b1: Back-up error b2: A/D conversion error b3 to b4: Unused b5: Logic output data error b6 to b15: Unused Data 0: OFF 1: ON [Decimal number: 0 to 63]	—
17	Unused	0400	1024	64	—	—	—

\* Uses the same register address in the Z-TIO module and Z-DIO module.

Continued on the next page.

Continued from the previous page.

No.	Name	Register address		Number of data items	Attribute	Data range	Factory set value
		HEX	DEC				
18	Output state monitor ♥	0440	1088	64	RO	Bit data b0: OUT1 state b1: OUT2 state b2: OUT3 state b3: OUT4 state b4 to b15: Unused Data 0: OFF 1: ON [Decimal number: 0 to 15]	—
19	Operation mode state monitor	0480	1152	64	RO	Bit data b0: Control STOP b1: Control RUN b2: Manual mode b3: Remote mode b4 to b15: Unused Data 0: OFF 1: ON [Decimal number: 0 to 15]	—
20	Memory area soak time monitor	04C0	1216	64	RO	0 to 11999 seconds or 0 to 5999 minutes Data range of Area soak time can be selected on the Soak time unit.	—
21	Integrated operating time monitor * ♥	0500	1280	64	RO	0 to 19999 hours	—
22	Holding peak value ambient temperature monitor	0540	1344	64	RO	-10.0 to +100.0 °C (14.0 to 212.0 °F)	—
23	Unused	0580	1408	64	—	—	—
24	Backup memory state monitor * ♥	05C0	1472	64	RO	0: The content of the backup memory does not coincide with that of the RAM. 1: The content of the backup memory coincides with that of the RAM.	—
25	Comprehensive event state	0600	1536	64	RO	Bit data b0: Event 1 state b1: Event 2 state b2: Event 3 state b3: Event 4 state b4: Heater break alarm state b5: Temperature rise completion b6: Burnout b7 to b15: Unused Data 0: OFF 1: ON [Decimal number: 0 to 127]	—

\* Uses the same register address in the Z-TIO module and Z-DIO module.

Continued on the next page.

Continued from the previous page.

No.	Name	Register address		Number of data items	Attribute	Data range	Factory set value
		HEX	DEC				
26	Logic output monitor ♥	0640	1600	64	RO	Bit data b0: Logic output 1 state b1: Logic output 2 state b2: Logic output 3 state b3: Logic output 4 state b4: Logic output 5 state b5: Logic output 6 state b6: Logic output 7 state b7: Logic output 8 state b8 to b15: Unused Data 0: OFF 1: ON [Decimal number: 0 to 255]	—
27	Digital input (DI) state ♣ ♥	0680	1664	64	RO	Bit data b0: DI 1 b1: DI 2 b2: DI 3 b3: DI 4 b4: DI 5 b5: DI 6 b6: DI 7 b7: DI 8 b8 to b15: Unused Data 0: Contact open 1: Contact closed [Decimal number: 0 to 255]	—
28	Digital output (DO) state ♣ ♥	06C0	1728	64	RO	Bit data b0: DO 1 b1: DO 2 b2: DO 3 b3: DO 4 b4: DO 5 b5: DO 6 b6: DO 7 b7: DO 8 b8 to b15: Unused Data 0: OFF 1: ON [Decimal number: 0 to 255]	—
29 ⋮ 32	Unused	0700 ⋮ 07C0	1792 ⋮ 1984	64 ⋮ 64	—	—	—
33	PID/AT transfer	0800	2048	64	R/W	0: PID control 1: Autotuning (AT) * * Automatically reverts to 0 after auto-tuning ends.	0
34	Auto/Manual transfer	0840	2112	64	R/W	0: Auto mode 1: Manual mode	0

Continued on the next page.

## 8. COMMUNICATION DATA LIST

Continued from the previous page.

No.	Name	Register address		Number of data items	Attribute	Data range	Factory set value
		HEX	DEC				
35	Remote/Local transfer	0880	2176	64	R/W	0: Local mode 1: Remote mode When performing remote control by remote setting input and also performing cascade control and ratio setting, transfer to the Remote mode.	0
36	RUN/STOP transfer * ♥	08C0	2240	64	R/W	0: RUN mode (Control start) 1: STOP mode (Control stop)	0
37	Memory area transfer	0900	2304	64	R/W	1 to 8	1
38	Interlock release	0940	2368	64	R/W	0: Normal state 1: Interlock release execution	0
39	Event 1 set value	0980	2432	64	R/W	Deviation action, Deviation action between channels, Temperature rise completion range: –Input span to +Input span	50
40	Event 2 set value	09C0	2496	64	R/W	Process action, SV action: Input scale low to Input scale high MV action: –5.0 to +105.0 %	50
41	Event 3 set value	0A00	2560	64	R/W	If the Event type corresponds to “0: None,” set to RO (Only reading data is possible). When temperature rise completion is selected at Event 3 action type.	50
42	Event 4 set value	0A40	2624	64	R/W	If Event 4 corresponds to “9: Control loop break alarm (LBA),” the Event 4 set value becomes RO (Only reading data is possible).	50
43	Control loop break alarm (LBA) time	0A80	2688	64	R/W	0 to 7200 seconds (0: Unused) If Event 4 is other than “9: Control loop break alarm (LBA),” set to RO (Only reading data is possible).	480
44	LBA deadband	0AC0	2752	64	R/W	0 (0.0) to Input span If Event 4 is other than “9: Control loop break alarm (LBA),” set to RO (Only reading data is possible).	0 (0.0)
45	Set value (SV)	0B00	2816	64	R/W	Setting limiter (low) to Setting limiter (high)	TC/RTD: 0 °C [°F] V/I: 0.0 %

\* Uses the same register address in the Z-TIO module and Z-DIO module.

Continued on the next page.

Continued from the previous page.

No.	Name	Register address		Number of data items	Attribute	Data range	Factory set value
		HEX	DEC				
46	Proportional band [heat-side] ◆	0B40	2880	64	R/W	TC/RTD inputs: 0 (0.0) to Input span (Unit: °C [°F]) Varies with the setting of the decimal point position selection. Voltage (V)/current (I) inputs: 0.0 to 1000.0 % of Input span 0 (0.0): ON/OFF action ON/OFF action for both heat and cool actions in case of a heat/cool control type.	TC/RTD: 30 V/I: 30.0
47	Integral time [heat-side] ◆	0B80	2944	64	R/W	PID control or heat/cool PID control: 0 to 3600 seconds or 0.0 to 1999.9 seconds (0, 0.0: PD action) Position proportioning control: 1 to 3600 seconds or 0.1 to 1999.9 seconds Varies with the setting of the integral/derivative time decimal point position selection.	240
48	Derivative time [heat-side] ◆	0BC0	3008	64	R/W	0 to 3600 seconds or 0.0 to 1999.9 seconds (0, 0.0: PI action) Varies with the setting of the integral/derivative time decimal point position selection.	60
49	Control response parameter ◆	0C00	3072	64	R/W	0: Slow 1: Medium 2: Fast [P or PD action: 2 (Fast) fixed]	PID control, Position proportioning control: 0 Heat/cool PID control: 2
50	Proportional band [cool-side] ◆	0C40	3136	64	R/W	TC/RTD inputs: 1 (0.1) to Input span (Unit: °C [°F]) Varies with the setting of the decimal point position selection. Voltage (V)/current (I) inputs: 0.1 to 1000.0 % of Input span If control is other than heat/cool PID control, set to RO (Only reading data is possible).	TC/RTD: 30 V/I: 30.0

Continued on the next page.

8. COMMUNICATION DATA LIST

Continued from the previous page.

No.	Name	Register address		Number of data items	Attribute	Data range	Factory set value
		HEX	DEC				
51	Integral time [cool-side] ◆	0C80	3200	64	R/W	0 to 3600 seconds or 0.0 to 1999.9 seconds (0, 0.0: PD action) Varies with the setting of the integral/derivative time decimal point position selection. If control is other than heat/cool PID control, set to RO (Only reading data is possible).	240
52	Derivative time [cool-side] ◆	0CC0	3264	64	R/W	0 to 3600 seconds or 0.0 to 1999.9 seconds (0, 0.0: PI action) Varies with the setting of the integral/derivative time decimal point position selection. If control is other than heat/cool PID control, set to RO (Only reading data is possible).	60
53	Overlap/Deadband ◆	0D00	3328	64	R/W	TC/RTD inputs: –Input span to +Input span (Unit:°C [°F]) Voltage (V)/current (I) inputs: –100.0 to +100.0 % of Input span Minus (–) setting results in overlap. However, the overlapping range is within the proportional range. If control is other than heat/cool PID control, set to RO (Only reading data is possible).	0
54	Manual reset	0D40	3392	64	R/W	–100.0 to +100.0 % If the integral function is valid, set to RO (Only reading data is possible). When integral action (heating or cooling side) is zero, manual reset value is added to the control output.	0.0
55	Setting change rate limiter (up)	0D80	3456	64	R/W	0 (0.0) to Input span/unit time * 0 (0.0): Unused	0 (0.0)
56	Setting change rate limiter (down)	0DC0	3520	64	R/W	* Unit time: 60 seconds (factory set value)	0 (0.0)

Continued on the next page.



Continued from the previous page.

No.	Name	Register address		Number of data items	Attribute	Data range	Factory set value
		HEX	DEC				
57	Area soak time	0E00	3584	64	R/W	0 minutes 00 seconds to 199 minutes 59 seconds: 0 to 11999 seconds 0 hours 00 minutes to 99 hours 59 minutes: 0 to 5999 minutes Data range of Area soak time can be selected on the Soak time unit.	0
58	Link area number	0E40	3648	64	R/W	0 to 8 (0: No link)	0
59	Heater break alarm (HBA) set value	0E80	3712	64	R/W	When CT is CTL-6-P-N: 0.0 to 30.0 A (0.0: Not used) When CT is CTL-12-S56-10L-N: 0.0 to 100.0 A (0.0: Not used) If there is no current transformer (CT) or CT is assigned to "0: None," set to RO (Only reading data is possible).	0.0
60	Heater break determination point	0EC0	3776	64	R/W	0.0 to 100.0 % of HBA set value (0.0: Heater break determination is invalid) If there is no current transformer (CT) or CT is assigned to "0: None," set to RO (Only reading data is possible). If Heater break alarm (HBA) corresponds to "0: Type A," set to RO (Only reading data is possible).	30.0
61	Heater melting determination point	0F00	3840	64	R/W	0.0 to 100.0 % of HBA set value (0.0: Heater melting determination is invalid) If there is no current transformer (CT) or CT is assigned to "0: None," set to RO (Only reading data is possible). If Heater break alarm (HBA) corresponds to "0: Type A," set to RO (Only reading data is possible).	30.0
62	Unused	0F40	3904	64	—	—	—
63	Unused	0F80	3968	64	—	—	—
64	Unused	0FC0	4032	64	—	—	—
65	PV bias	1000	4096	64	R/W	-Input span to +Input span	0
66	PV digital filter	1040	4160	64	R/W	0.0 to 100.0 seconds (0.0: Unused)	0.0
67	PV ratio	1080	4224	64	R/W	0.500 to 1.500	1.000
68	PV low input cut-off	10C0	4288	64	R/W	0.00 to 25.00 % of input span If the Input square root extraction corresponds to "0: Unused," set to RO (Only reading data is possible).	0.00

Continued on the next page.

8. COMMUNICATION DATA LIST

Continued from the previous page.

No.	Name	Register address		Number of data items	Attribute	Data range	Factory set value
		HEX	DEC				
69	RS bias *	1100	4352	64	R/W	-Input span to +Input span	0
70	RS digital filter *	1140	4416	64	R/W	0.0 to 100.0 seconds (0.0: Unused)	0.0
71	RS ratio *	1180	4480	64	R/W	0.001 to 9.999	1.000
72	Proportional cycle time	11C0	4544	64	R/W	0.1 to 100.0 seconds M: Relay contact output V: Voltage pulse output T: Triac output D: Open collector output This item becomes RO (Only reading data is possible) for the voltage/current output specification.	M output: 20.0 V, T, D output: 2.0
73	Unused	1200	4608	64	—	—	—
74	Manual manipulated output value ◆	1240	4672	64	R/W	PID control: Output limiter (low) to Output limiter (high) Heat/cool PID control: -Cool-side output limiter (high) to +Heat-side output limiter (high) Position proportioning control: When there is feedback resistance (FBR) input and it does not break: Output limiter (low) to Output limiter (high) When there is no feedback resistance (FBR) input or the feedback resistance (FBR) input is disconnected: 0: Close-side output OFF, Open-side output OFF 1: Close-side output ON, Open-side output OFF 2: Close-side output OFF, Open-side output ON	0.0
75 ⋮ 82	Unused	1280 ⋮ 1440	4736 ⋮ 5184	64 ⋮ 64	—	—	—

\* Data on RS bias, RS ratio and RS digital filter is that in cascade control or ratio setting.

Continued on the next page.

Continued from the previous page.

No.	Name	Register address		Number of data items	Attribute	Data range	Factory set value
		HEX	DEC				
<b>Data Nos. 83 to 203 are engineering setting data. [Writable in the STOP mode]</b>							
83	Input type	1480	5248	64	R/W	0: TC input K 1: TC input J 2: TC input R 3: TC input S 4: TC input B 5: TC input E 6: TC input N 7: TC input T 8: TC input W5Re/W26Re 9: TC input PLII 12: RTD input Pt100 13: RTD input JPt100 14: Current input 0 to 20 mA DC 15: Current input 4 to 20 mA DC 16: Voltage (high) input 0 to 10 V DC 17: Voltage (high) input 0 to 5 V DC 18: Voltage (high) input 1 to 5 V DC 19: Voltage (low) input 0 to 1 V DC 20: Voltage (low) input 0 to 100 mV DC 21: Voltage (low) input 0 to 10 mV DC 22: Feedback resistance input 100 to 150 $\Omega$ 23: Feedback resistance input 151 $\Omega$ to 6 k $\Omega$ If changed to voltage (high) input from TC/RTD/current/voltage (low)/feedback resistance input, select the hardware by the input selector switch at the side of the module. For the selecting procedure, see <b>SRZ Instruction Manual (IMS01T04-E□)</b> .	Depends on model code  When not specifying: 0
84	Display unit	14C0	5312	64	R/W	0: °C 1: °F The engineering unit for voltage/current input is expressed as %.	0
85	Decimal point position	1500	5376	64	R/W	0: No decimal place 1: One decimal place 2: Two decimal places 3: Three decimal places 4: Four decimal places TC input: • K, J, T, E: Only 0 or 1 can be set. • R, S, B, N, PLII, W5Re/W26Re: Only 0 can be set. RTD input: Only 0 or 1 can be set. V/I inputs: From 0 to 4 can be set.	Depends on model code  When not specifying: TC/RTD: 1 V/I: 1

Continued on the next page.

8. COMMUNICATION DATA LIST

Continued from the previous page.

No.	Name	Register address		Number of data items	Attribute	Data range	Factory set value
		HEX	DEC				
86	Input scale high	1540	5440	64	R/W	TC/RTD inputs: Input scale low to Maximum value of the selected input range Voltage (V)/current (I) inputs: -19999 to +19999 Varies with the setting of the decimal point position	TC/RTD: Maximum value of the selected input range V/I: 100.0
87	Input scale low	1580	5504	64	R/W	TC/RTD inputs: Minimum value of the selected input range to Input scale high Voltage (V)/current (I) inputs: -19999 to +19999 Varies with the setting of the decimal point position	TC/RTD: Minimum value of the selected input range V/I: 0.0
88	Input error determination point (high)	15C0	5568	64	R/W	Input error determination point (low) to (Input range high + 5 % of input span)	Input scale high + (5 % of input span)
89	Input error determination point (low)	1600	5632	64	R/W	(Input range low - 5 % of input span) to Input error determination point (high)	Input scale low - (5 % of input span)
90	Burnout direction	1640	5696	64	R/W	0: Upscale 1: Downscale Valid only when the TC input and voltage (low) input are selected.	0
91	Square root extraction	1680	5760	64	R/W	0: Unused 1: Used	0
92	Unused	16C0	5824	64	—	—	—
93		⋮	⋮	⋮			
95		1780	6016	64			
96	Output assignment (Logic output selection function)	17C0	6080	64	R/W	0: Control output 1: Logic output result 2: FAIL output	0
97	Unused	1800	6144	64	—	—	—
98		⋮	⋮	⋮			
100		18C0	6336	64			
101	Energized/De-energized (Logic output selection function)	1900	6400	64	R/W	0: Energized 1: De-energized	0
102	Unused	1940	6464	64	—	—	—
103		⋮	⋮	⋮			
113		1C00	7168	64			

Continued on the next page.

Continued from the previous page.

No.	Name	Register address		Number of data items	Attribute	Data range	Factory set value
		HEX	DEC				
114	Event 1 type	1C40	7232	64	R/W	0: None 1: Deviation high (Using SV monitor value) <sup>1</sup> 2: Deviation low (Using SV monitor value) <sup>1</sup> 3: Deviation high/low (Using SV monitor value) <sup>1</sup> 4: Band (Using SV monitor value) <sup>1</sup> 5: Process high <sup>1</sup> 6: Process low <sup>1</sup> 7: SV high 8: SV low 9: Unused 10: MV high [heat-side] <sup>1,2</sup> 11: MV low [heat-side] <sup>1,2</sup> 12: MV high [cool-side] <sup>1</sup> 13: MV low [cool-side] <sup>1</sup> 14: Deviation high (Using local SV) <sup>1</sup> 15: Deviation low (Using local SV) <sup>1</sup> 16: Deviation high/low (Using local SV) <sup>1</sup> 17: Deviation (Using local SV) <sup>1</sup> 18: Deviation between channels high <sup>1</sup> 19: Deviation between channels low <sup>1</sup> 20: Deviation between channels high/low <sup>1</sup> 21: Deviation between channels band <sup>1</sup> <sup>1</sup> Event hold action is available. <sup>2</sup> If there is feedback resistance (FBR) input in position proportioning control, set to the feedback resistance (FBR) input value.	Depends on model code.  When not specifying: 0
115	Event 1 hold action	1C80	7296	64	R/W	0: OFF 1: Hold action ON (At power turned on) 2: Re-hold action ON (At power turned on and SV changed) This function is valid when input value, deviation or manipulated value action has been selected. In case of a deviation action, this function is not available while in remote mode and while setting changing rate limiter is working.	Depends on model code.  When not specifying: 0
116	Event 1 interlock	1CC0	7360	64	R/W	0: Unused 1: Used	0
117	Event 1 differential gap	1D00	7424	64	R/W	① Deviation, process, set value or Deviation action between channels: 0 to Input span (Unit: °C [°F]) ② MV: 0.0 to 110.0 %	① TC/RTD: 1 °C [°F] V/I: 0.1 % ② 0.1 %
118	Event 1 delay timer	1D40	7488	64	R/W	0 to 18000 seconds	0

Continued on the next page.

Continued from the previous page.

No.	Name	Register address		Number of data items	Attribute	Data range	Factory set value
		HEX	DEC				
119	Force ON of Event 1 action	1D80	7552	64	R/W	Bit data b0: Event output turned on at input error occurrence b1: Event output turned on in manual mode b2: Event output turned on during the autotuning (AT) function is being executed b3: Event output turned on during the setting change rate limiter is being operated b4 to b15: Unused Data 0: Invalid 1: Valid [Decimal number: 0 to 15]	0
120	Event 2 type	1DC0	7616	64	R/W	Same as Event 1 type	
121	Event 2 hold action	1E00	7680	64	R/W	Same as Event 1 hold action	
122	Event 2 interlock	1E40	7744	64	R/W	Same as Event 1 interlock	
123	Event 2 differential gap	1E80	7808	64	R/W	Same as Event 1 differential gap	
124	Event 2 delay timer	1EC0	7872	64	R/W	Same as Event 1 delay timer	
125	Force ON of Event 2 action	1F00	7936	64	R/W	Same as Force ON of Event 1 action	
126	Event 3 type	1F40	8000	64	R/W	0: None 1: Deviation high (SV monitor value used) <sup>1</sup> 2: Deviation low (SV monitor value used) <sup>1</sup> 3: Deviation high/low (SV monitor value used) <sup>1</sup> 4: Band (SV monitor value used) <sup>1</sup> 5: Process high <sup>1</sup> 6: Process low <sup>1</sup> 7: SV high 8: SV low 9: Temperature rise completion 10: MV high [heat-side] <sup>1,2</sup> 11: MV low [heat-side] <sup>1,2</sup> 12: MV high [cool-side] <sup>1</sup> 13: MV low [cool-side] <sup>1</sup> 14: Deviation high (Local SV value used) <sup>1</sup> 15: Deviation low (Local SV value used) <sup>1</sup> 16: Deviation high/low (Local SV value used) <sup>1</sup> 17: Deviation (Local SV value used) <sup>1</sup> 18: Deviation between channels high <sup>1</sup> 19: Deviation between channels low <sup>1</sup> 20: Deviation between channels high/low <sup>1</sup> 21: Deviation between channels band <sup>1</sup> <sup>1</sup> Event hold action is available. <sup>2</sup> If there is feedback resistance (FBR) input in position proportioning control, set to the feedback resistance (FBR) input value.	Depends on model code  When not specifying: 0

Continued on the next page.

Continued from the previous page.

No.	Name	Register address		Number of data items	Attribute	Data range	Factory set value
127	Event 3 hold action	1F80	8064	64	R/W	Same as Event 1 hold action	
128	Event 3 interlock	1FC0	8128	64	R/W	Same as Event 1 interlock	
129	Event 3 differential gap	2000	8192	64	R/W	Same as Event 1 differential gap	
130	Event 3 delay timer	2040	8256	64	R/W	0 to 18000 seconds If Event 3 corresponds to "9: Temperature rise completion," the Event 3 delay timer becomes the temperature rise completion soak time.	0
131	Force ON of Event 3 action	2080	8320	64	R/W	Same as Force ON of Event 1 action	
132	Event 4 type	20C0	8384	64	R/W	0: None 1: Deviation high (SV monitor value used) <sup>1</sup> 2: Deviation low (SV monitor value used) <sup>1</sup> 3: Deviation high/low (SV monitor value used) <sup>1</sup> 4: Band (SV monitor value used) <sup>1</sup> 5: Process high <sup>1</sup> 6: Process low <sup>1</sup> 7: SV high 8: SV low 9: Control loop break alarm (LBA) 10: MV high [heat-side] <sup>1, 2</sup> 11: MV low [heat-side] <sup>1, 2</sup> 12: MV high [cool-side] <sup>1</sup> 13: MV low [cool-side] <sup>1</sup> 14: Deviation high (Local SV value used) <sup>1</sup> 15: Deviation low (Local SV value used) <sup>1</sup> 16: Deviation high/low (Local SV value used) <sup>1</sup> 17: Deviation (Local SV value used) <sup>1</sup> 18: Deviation between channels high <sup>1</sup> 19: Deviation between channels low <sup>1</sup> 20: Deviation between channels high/low <sup>1</sup> 21: Deviation between channels band <sup>1</sup> <sup>1</sup> Event hold action is available. <sup>2</sup> If there is feedback resistance (FBR) input in position proportioning control, set to the feedback resistance (FBR) input value.	Depends on model code.  When not specifying: 0
133	Event 4 hold action	2100	8448	64	R/W	Same as Event 1 hold action	
134	Event 4 interlock	2140	8512	64	R/W	Same as Event 1 interlock	

Continued on the next page.

## 8. COMMUNICATION DATA LIST

Continued from the previous page.

No.	Name	Register address		Number of data items	Attribute	Data range	Factory set value
		HEX	DEC				
135	Event 4 differential gap	2180	8576	64	R/W	① Deviation, process, set value or Deviation action between channels: 0 to Input span (Unit: °C [°F]) ② MV: 0.0 to 110.0 % Becomes invalid when the Event 4 type corresponds to “9: Control loop break alarm (LBA).”	① TC/RTD: 1 °C [°F] V/I: 0.1 % ② 0.1 %
136	Event 4 delay timer	21C0	8640	64	R/W	Same as Event 1 delay timer	
137	Force ON of Event 4 action	2200	8704	64	R/W	Same as Force ON of Event 1 action	
138	CT ratio	2240	8768	64	R/W	0 to 9999	CTL-6-P-N: 800 CTL-12-S56-10L-N: 1000
139	CT assignment	2280	8832	64	R/W	0: None 1: OUT1 2: OUT2 3: OUT3 4: OUT4	1
140	Heater break alarm (HBA) type	22C0	8896	64	R/W	0: Heater break alarm (HBA) type A (Time-proportional control output) 1: Heater break alarm (HBA) type B (Continuous control output and time-proportional control output)	1
141	Number of heater break alarm (HBA) delay times	2300	8960	64	R/W	0 to 255 times	5
142	Unused	2340	9024	64	—	—	—
⋮	⋮	⋮	⋮	⋮	⋮	⋮	⋮
145		2400	9216	64			
146	Hot/Cold start	2440	9280	64	R/W	0: Hot start 1 1: Hot start 2 2: Cold start	0
147	Start determination point	2480	9344	64	R/W	0 to Input span (The unit is the same as input value.) (0: Action depending on the Hot/Cold start selection)	3 % of input span
148	Unused	24C0	9408	64	—	—	—
149	Unused	2500	9472	64	—	—	—
150	SV tracking	2540	9536	64	R/W	0: Unused 1: Used	1
151	MV transfer function [Action taken when changed to Manual mode from Auto mode]	2580	9600	64	R/W	0: MV in Auto mode is used. [Balanceless-bumpless function] 2: MV in previous Manual mode is used.	0

Continued on the next page.



Continued from the previous page.

No.	Name	Register address		Number of data items	Attribute	Data range	Factory set value
		HEX	DEC				
152	Control action	25C0	9664	64	R/W	0: Brilliant II PID control (direct action) 1: Brilliant II PID control (reverse action) 2: Brilliant II Heat/Cool PID control [water cooling] 3: Brilliant II Heat/Cool PID control [air cooling] 4: Brilliant II Heat/Cool PID control [Cooling gain linear type] 5: Position proportioning control	Depends on model code.  When not specifying: 1
153	Integral/derivative time decimal point position ◆	2600	9728	64	R/W	0: 1 second setting (No decimal place) 1: 0.1 seconds setting (One decimal place)	0
154	Derivative action ◆	2640	9792	64	R/W	0: Measured value derivative 1: Deviation derivative	0
155	Undershoot suppression factor ◆	2680	9856	64	R/W	0.000 to 1.000	Water cooling: 0.100 Air cooling: 0.250 Cooling gain linear type: 1.000
156	Derivative gain ◆	26C0	9920	64	R/W	0.1 to 10.0	6.0
157	ON/OFF action differential gap (upper) ◆	2700	9984	64	R/W	TC/RTD inputs: 0 to Input span (Unit: °C [°F]) Voltage (V)/current (I) inputs: 0.0 to 100.0 % of input span	TC/RTD: 1 °C [°F] V/I: 0.1 %
158	ON/OFF action differential gap (lower) ◆	2740	10048	64	R/W		TC/RTD: 1 °C [°F] V/I: 0.1 %
159	Action (high) at input error ◆	2780	10112	64	R/W	0: Normal control 1: Manipulated output value at input error	0
160	Action (low) at input error ◆	27C0	10176	64	R/W		0
161	Manipulated output value at input error ◆	2800	10240	64	R/W	-105.0 to +105.0 % Actual output values become those restricted by the output limiter. Position proportioning control: If there is no feedback resistance (FBR) input or the feedback resistance (FBR) input is disconnected, an action taken when abnormal is in accordance with the value action setting during STOP.	0.0

Continued on the next page.

Continued from the previous page.

No.	Name	Register address		Number of data items	Attribute	Data range	Factory set value
		HEX	DEC				
162	Manipulated output value at STOP mode [heat-side] ◆	2840	10304	64	R/W	-5.0 to +105.0 % Position proportioning control: Only when there is feedback resistance (FBR) input and it does not break, the manipulated output value [heat-side] at STOP is output.	-5.0
163	Manipulated output value at STOP mode [cool-side] ◆	2880	10368	64	R/W		-5.0
164	Output change rate limiter (up) [heat-side] ◆	28C0	10432	64	R/W	0.0 to 100.0 %/seconds (0.0: OFF) Becomes invalid when in position proportioning control.	0.0
165	Output change rate limiter (down) [cool-side] ◆	2900	10496	64	R/W		0.0
166	Output limiter (high) [heat-side] ◆	2940	10560	64	R/W	Output limiter (low) to 105.0 % Position proportioning control: Becomes valid only when there is feedback resistance (FBR) input and it does not break.	105.0
167	Output limiter (low) [heat-side] ◆	2980	10624	64	R/W	-5.0 % to Output limiter (high) [MV1] Position proportioning control: Becomes valid only when there is feedback resistance (FBR) input and it does not break.	-5.0
168	Output change rate limiter (up) [cool-side] ◆	29C0	10688	64	R/W	0.0 to 100.0 %/seconds (0.0: OFF) Becomes invalid when in position proportioning control.	0.0
169	Output change rate limiter (down) [cool-side] ◆	2A00	10752	64	R/W		0.0
170	Output limiter (high) [cool-side] ◆	2A40	10816	64	R/W	Output limiter (low) [cool-side] to 105.0 %	105.0
171	Output limiter (low) [cool-side] ◆	2A80	10880	64	R/W	-5.0 % to Output limiter (high) [cool-side]	-5.0
172	Unused	2AC0	10944	64	—	—	—
173	Unused	2B00	11008	64	—	—	—
174	AT bias ◆	2B40	11072	64	R/W	-Input span to +Input span	0
175	AT cycles ◆	2B80	11136	64	R/W	0: 1.5 cycles 1: 2.0 cycles 2: 2.5 cycles 3: 3.0 cycles	1

Continued on the next page.

Continued from the previous page.

No.	Name	Register address		Number of data items	Attribute	Data range	Factory set value
		HEX	DEC				
176	Output value with AT turned on ◆	2BC0	11200	64	R/W	Output value with AT turned off to 105.0 % Actual output values become those restricted by the output limiter. Position proportioning control: Becomes valid only when there is feedback resistance (FBR) input and it does not break (high limit of feedback resistance input at AT).	105.0
177	Output value with AT turned off ◆	2C00	11264	64	R/W	-105.0 % to Output value with AT turned on Actual output values become those restricted by the output limiter. Position proportioning control: Becomes valid only when there is feedback resistance (FBR) input and it does not break (high limit of feedback resistance input at AT).	-105.0
178	AT differential gap time ◆	2C40	11328	64	R/W	0.0 to 50.0 seconds	10.0
179	Proportional band adjusting factor [heat-side] ◆	2C80	11392	64	R/W	0.01 to 10.00 times	1.00
180	Integral time adjusting factor [heat-side] ◆	2CC0	11456	64	R/W		1.00
181	Derivative time adjusting factor [heat-side] ◆	2D00	11520	64	R/W		1.00
182	Proportional band adjusting factor [cool-side] ◆	2D40	11584	64	R/W		1.00
183	Integral time adjusting factor [cool-side] ◆	2D80	11648	64	R/W		1.00
184	Derivative time adjusting factor [cool-side] ◆	2DC0	11712	64	R/W		1.00
185	Proportional band limiter (high) [heat-side] ◆	2E00	11776	64	R/W	TC/RTD inputs: 0 (0.0) to Input span (Unit: °C [°F]) Varies with the setting of the decimal point position selection. Voltage (V)/current (I) inputs: 0.0 to 1000.0 % of input span	TC/RTD: Input span V/I: 1000.0 %
186	Proportional band limiter (low) [heat-side] ◆	2E40	11840	64	R/W	0 (0.0): ON/OFF action (ON/OFF action for both heat and cool actions in case of a heat/cool control type.)	TC/RTD: 0 V/I: 0.0 %

Continued on the next page.

8. COMMUNICATION DATA LIST

Continued from the previous page.

No.	Name	Register address		Number of data items	Attribute	Data range	Factory set value
		HEX	DEC				
187	Integral time limiter (high) [heat-side] ◆	2E80	11904	64	R/W	PID control or heat/cool PID control: 0 to 3600 seconds or 0.0 to 1999.9 seconds	3600
188	Integral time limiter (low) [heat-side] ◆	2EC0	11968	64	R/W	Position proportioning control: 1 to 3600 seconds or 0.1 to 1999.9 seconds Varies with the setting of the integral/derivative time decimal point position selection.	PID control, Heat/cool PID control: 0 Position proportionin g control: 1
189	Derivative time limiter (high) [heat-side] ◆	2F00	12032	64	R/W	0 to 3600 seconds or 0.0 to 1999.9 seconds Varies with the setting of the integral/derivative time decimal point position selection.	3600
190	Derivative time limiter (low) [heat-side] ◆	2F40	12096	64	R/W	0 to 3600 seconds or 0.0 to 1999.9 seconds Varies with the setting of the integral/derivative time decimal point position selection.	0
191	Proportional band limiter (high) [cool-side] ◆	2F80	12160	64	R/W	TC/RTD inputs: 1 to input span or 0.1 to input span (Unit: °C [°F]) Varies with the setting of the decimal point position selection.	TC/RTD: Input span V/I: 1000.0 %
192	Proportional band limiter (low) [cool-side] ◆	2FC0	12224	64	R/W	Voltage (V)/current (I) inputs: 0.1 to 1000.0 % of input span	TC/RTD: 1 (0.1) V/I: 0.1 %
193	Integral time limiter (high) [cool-side] ◆	3000	12288	64	R/W	0 to 3600 seconds or 0.0 to 1999.9 seconds Varies with the setting of the integral/derivative time decimal point position selection.	3600
194	Integral time limiter (low) [cool-side] ◆	3040	12352	64	R/W	If control is other than heat/cool PID control, set to RO (Only reading data is possible).	0
195	Derivative time limiter (high) [cool-side] ◆	3080	12416	64	R/W	0 to 3600 seconds or 0.0 to 1999.9 seconds Varies with the setting of the integral/derivative time decimal point position selection.	3600
196	Derivative time limiter (low) [cool-side] ◆	30C0	12480	64	R/W	If control is other than heat/cool PID control, set to RO (Only reading data is possible).	0
197	Open/Close output neutral zone ◆	3100	12544	64	R/W	0.1 to 10.0 % of output	2.0
198	Unused	3140	12308	64	—	—	—
199	Action at feedback resistance (FBR) input break ◆	3180	12672	64	R/W	0: Action depending on the valve action at STOP 1: Control action continued	0

Continued on the next page.

Continued from the previous page.

No.	Name	Register address		Number of data items	Attribute	Data range	Factory set value
		HEX	DEC				
200	Feedback adjustment ◆	31C0	12736	64	R/W	0: Adjustment end 1: Open-side adjustment start 2: Close-side adjustment start	—
201	Control motor time ◆	3200	12800	64	R/W	5 to 1000 seconds	10
202	Integrated output limiter ◆	3240	12864	64	R/W	0.0 to 200.0 % of control motor time (0.0: OFF) Becomes invalid when there is feedback resistance (FBR) input.	150.0
203	Valve action at STOP ◆	3280	12928	64	R/W	0: Close-side output OFF, Open-side output OFF 1: Close-side output ON, Open-side output OFF 2: Close-side output OFF, Open-side output ON Becomes valid when there is no feedback resistance (FBR) input or the feedback resistance (FBR) input is disconnected.	0
<b>Data No. 204 is normal setting data.</b>							
204	Startup tuning (ST)	32C0	12992	64	R/W	0: ST unused 1: Execute once * 2: Execute always * Automatically reverts to 0 after Startup tuning (ST) ends. The startup tuning (ST) function is activated according to the ST start condition selected. If control is other than position proportioning control, set to RO (Only reading data is possible).	0
<b>Data Nos. 205 to 209 are engineering setting data. [Writable in the STOP mode]</b>							
205	ST proportional band adjusting factor ◆	3300	13056	64	R/W	0.01 to 10.00 times	1.00
206	ST integral time adjusting factor ◆	3340	13120	64	R/W		1.00
207	ST derivative time adjusting factor ◆	3380	13184	64	R/W		1.00

Continued on the next page.

Continued from the previous page.

No.	Name	Register address		Number of data items	Attribute	Data range	Factory set value
		HEX	DEC				
208	ST start condition ◆	33C0	13248	64	R/W	0: Activate the startup tuning (ST) function when the power is turned on; when transferred from STOP to RUN; or when the set value (SV) is changed. 1: Activate the startup tuning (ST) function when the power is turned on; or when transferred from STOP to RUN. 2: Activate the startup tuning (ST) function when the set value (SV) is changed.	0
209	Automatic temperature rise group ◆	3400	13312	64	R/W	0 to 16 (0: Automatic temperature rise function OFF)	0
<b>Data No. 210 is normal setting data.</b>							
210	Automatic temperature rise learning	3440	13376	64	R/W	0: Unused 1: Learning * * Automatically reverts to 0 after automatic temperature rise learning ends. If the Automatic temperature rise group corresponds to "0: Automatic temperature rise function OFF," set to RO (Only reading data is possible).	1
<b>Data Nos. 211 to 256 are engineering setting data. [Writable in the STOP mode]</b>							
211	Automatic temperature rise dead time ◆	3480	13440	64	R/W	0.1 to 1999.9 seconds	10.0
212	Automatic temperature rise gradient data ◆	34C0	13504	64	R/W	0.1 to Input span/minutes	1.0
213	Unused	3500	13568	64	—	—	—
214	Setting change rate limiter unit time	3540	13632	64	R/W	1 to 3600 seconds	60
215	Soak time unit	3580	13696	64	R/W	0: 0 to 5999 minutes [0 hours 00 minutes to 99 hours 59 minutes] 1: 0 to 11999 seconds [0 minutes 00 seconds to 199 minutes 59 seconds] Set the data range of Memory area soak time monitor and Area soak time.	1
216	Setting limiter (high)	35C0	13760	64	R/W	Setting limiter (low) to Input scale high	Input scale high
217	Setting limiter (low)	3600	13824	64	R/W	Input scale low to Setting limiter (high)	Input scale low

Continued on the next page.

Continued from the previous page.

No.	Name	Register address		Number of data items	Attribute	Data range	Factory set value
218	PV transfer function ◆	3640	13888	64	R/W	0: Unused 1: Used	0
219	Unused	3680	13952	64	—	—	—
220	Event 1 channel setting	36C0	14016	64	R/W	1: Channel 1 2: Channel 2 3: Channel 3 4: Channel 4 This function is valid when "deviation between channels" is selected	1
221	Event 2 channel setting	3700	14080	64	R/W		1
222	Event 3 channel setting	3740	14144	64	R/W		1
223	Event 4 channel setting	3780	14208	64	R/W		1
224	EDS transfer time decimal point position ◆	37C0	14272	64	R/W	0: 1 second setting (No decimal place) 1: 0.1 seconds setting (One decimal place)	0
225	Output average processing time for EDS ◆	3800	14336	64	R/W	0.1 to 200.0 seconds	1.0
226	Responsive action trigger point for EDS ◆	3840	14400	64	R/W	0 to Input span (Unit: °C [°F], %)	1
227	Operation mode assignment 1 (Logic output selection function) Logic output 1 to 4	3880	14464	64	R/W	0: No assignment 1: Operation mode (monitor, control) 2: Operation mode (monitor, event function, control) 3: Auto/Manual 4: Remote/Local 5: Interlock release	0
228	Operation mode assignment 2 (Logic output selection function) Logic output 5 to 8	38C0	14528	64	R/W		0
229	SV select function	3900	14592	64	R/W	0: Remote SV function 1: Cascade control function 2: Ratio setting function 3: Cascade control 2 function	0
230	Remote SV function master channel module address	3940	14656	64	R/W	-1 (Master channel is selected from itself) 0 to 99 (Master channel is selected from other modules)	-1
231	Remote SV function master channel selection	3980	14720	64	R/W	1 to 99	1
232	Output distribution master channel module address	39C0	14784	64	R/W	-1 (Master channel is selected from itself) 0 to 99 (Master channel is selected from other modules)	-1
233	Output distribution master channel selection	3A00	14848	64	R/W	1 to 99	1

Continued on the next page.

Continued from the previous page.

No.	Name	Register address		Number of data items	Attribute	Data range	Factory set value
234	Address of interacting modules	3A40	14912	64	R/W	-1 (Interact with its own module address) 0 to 99 (Interact with the addresses of other modules)	-1
235	Channel selection of interacting modules	3A80	14976	64	R/W	1 to 99 Becomes valid when the selected module is "Z-TIO module."	1
236	Selection switch of interacting modules	3AC0	15040	64	R/W	Bit data b0: Memory area number b1: Operation mode b2: Auto/Manual b3: Remote/Local b4: EDS start signal b5: Interlock release b6: Suspension of area soak time b7 to b15: Unused Data 0: No interaction 1: Interact with other channels [Decimal number: 0 to 127]	0
237	Control RUN/STOP holding setting *	3B00	15104	64	R/W	0: Not holding (STOP start) 1: Holding (RUN/STOP hold)	1
238	Interval time *	3B40	15168	64	R/W	0 to 250 ms	10
239	DI function assignment ♣	3B80	15232	64	R/W	0 to 29 (See page 78)	Depends on model code. When not specifying: 0
240	Memory area setting signal ♣	3BC0	15296	64	R/W	0: Valid 1: Invalid	1
241	DO signal assignment module address 1 ♣	3C00	15360	64	R/W	-1, 0 to 99 When "-1" is selected, all of the signals of the same type (except temperature rise completion and DO manual output value) are <i>OR</i> -operated and produced as outputs from DO.	-1
242	DO signal assignment module address 2 ♣	3C40	15424	64	R/W		-1
243	DO output assignment 1 [DO1 to DO4] ♣	3C80	15488	64	R/W	0 to 13 (See page 79)	Depends on model code. When not specifying: 0

\* Uses the same register address in the Z-TIO module and Z-DIO module.

Continued on the next page.



Continued from the previous page.

No.	Name	Register address		Number of data items	Attribute	Data range	Factory set value
244	DO output assignment 2 [DO5 to DO8] ♣	3CC0	15552	64	R/W	0 to 13 (See page 79)	Depends on model code. When not specifying: 0
245	DO energized/ de-energized ♣	3D00	15616	64	R/W	0: Energized 1: De-energized	0
246	DO output distribution master channel module address ♣	3D40	15680	64	R/W	-1 (Master channel is selected from itself) 0 to 99 (Master channel is selected from other modules)	-1
247	DO output distribution master channel selection ♣	3D80	15744	64	R/W	1 to 99	1
248	DO manipulated output value at STOP mode ♣	3DC0	15808	64	R/W	-5.0 to +105.0 %	-5.0
249	DO output limiter (high) ♣	3E00	15872	64	R/W	DO output limiter (low) to 105.0 %	105.0
250	DO output limiter (low) ♣	3E40	15936	64	R/W	-5.0 % to DO output limiter (high)	-5.0
251	Unused	3E80	16000	64	—	—	—
⋮		⋮	⋮	⋮			
256		3FC0	16320	64			
<b>Data Nos. 257 to 277 are memory area setting data. See 8.3 Memory Area Data Items (P. 80)</b>							
<b>Data Nos. 278 to 319 are normal setting data.</b>							
278	Unused	4540	17728	64	—	—	—
⋮		⋮	⋮	⋮			
288		47C0	18368	64			
289	Output distribution selection	4800	18432	64	R/W	0: Control output 1: Distribution output	0
290	Output distribution bias	4840	18496	64	R/W	-100.0 to +100.0 %	0.0
291	Output distribution ratio	4880	18560	64	R/W	-9.999 to +9.999	1.000
292	Minimum ON/OFF time of proportioning cycle	48C0	18624	64	R/W	0 to 1000 ms This item becomes RO (Only reading data is possible) for the voltage/current output specification.	0

Continued on the next page.

8. COMMUNICATION DATA LIST

Continued from the previous page.

No.	Name	Register address		Number of data items	Attribute	Data range	Factory set value
293	Area soak time stop function	4900	18688	64	R/W	0: No function 1: Event 1 2: Event 2 3: Event 3 4: Event 4	0
294	EDS mode (for disturbance 1)	4940	18752	64	R/W	0: No function 1: EDS function mode 2: Learning mode 3: Tuning mode	0
295	EDS mode (for disturbance 2)	4980	18816	64	R/W	EDS function: External disturbance suppression function	0
296	EDS value 1 (for disturbance 1)	49C0	18880	64	R/W	-100.0 to +100.0 %	0.0
297	EDS value 1 (for disturbance 2)	4A00	18944	64	R/W		0.0
298	EDS value 2 (for disturbance 1)	4A40	19008	64	R/W	-100.0 to +100.0 %	0.0
299	EDS value 2 (for disturbance 2)	4A80	19072	64	R/W		0.0
300	EDS transfer time (for disturbance 1)	4AC0	19136	64	R/W	0 to 3600 seconds or 0.0 to 1999.9 seconds	0
301	EDS transfer time (for disturbance 2)	4B00	19200	64	R/W		0
302	EDS action time (for disturbance 1)	4B40	19264	64	R/W	1 to 3600 seconds	600
303	EDS action time (for disturbance 2)	4B80	19328	64	R/W		600
304	EDS action wait time (for disturbance 1)	4BC0	19392	64	R/W	0.0 to 600.0 seconds	0.0
305	EDS action wait time (for disturbance 2)	4C00	19456	64	R/W		0.0
306	EDS value learning times	4C40	19520	64	R/W	0 to 10 times (0: No learning mode)	1
307	EDS start signal	4C80	19584	64	R/W	0: EDS start signal OFF 1: EDS start signal ON (for disturbance 1) 2: EDS start signal ON (for disturbance 2)	0
308	Operation mode	4CC0	19648	64	R/W	0: Unused 1: Monitor 2: Monitor + Event function 3: Control	3

Continued on the next page.

Continued from the previous page.

No.	Name	Register address		Number of data items	Attribute	Data range	Factory set value
309	Communication switch for logic	4D00	19712	64	R/W	Bit data b0: Communication switch 1 b1: Communication switch 2 b2: Communication switch 3 b3: Communication switch 4 b4 to b15: Unused Data 0: OFF 1: ON [Decimal number: 0 to 15]	0
310	DO manual output ♣	4D40	19776	64	R/W	Bit data b0: DO1 manual output b1: DO2 manual output b2: DO3 manual output b3: DO4 manual output b4: DO5 manual output b5: DO6 manual output b6: DO7 manual output b7: DO8 manual output b8 to b15: Unused Data 0: OFF 1: ON [Decimal number: 0 to 255]	0
311	DO output distribution selection ♣	4D80	19840	64	R/W	0: DO output 1: Distribution output	0
312	DO output distribution bias ♣	4DC0	19904	64	R/W	-100.0 to +100.0 %	0.0
313	DO output distribution ratio ♣	4E00	19968	64	R/W	-9.999 to +9.999	1.000
314	DO proportional cycle time ♣	4E40	20032	64	R/W	0.1 to 100.0 seconds M: Relay contact output D: Open collector output	M output: 20.0 D output: 2.0
315	DO minimum ON/OFF time of proportioning cycle ♣	4E80	20096	64	R/W	0 to 1000 ms	0
316 ⋮ 319	Unused	4EC0 ⋮ 4F80	20160 ⋮ 20352	64 ⋮ 64	—	—	—

# 8. COMMUNICATION DATA LIST

## ● DI assignment table

Set value	DI1	DI2	DI3	DI4	DI5	DI6	DI7	DI8	
0	No assignment								
1	Memory area transfer (1 to 8) <sup>1</sup>				Area set <sup>2</sup>		Operation mode <sup>3</sup>		AUTO/MAN <sup>4</sup>
2									REM/LOC <sup>4</sup>
3									EDS start signal 1
4									Soak stop
5									RUN/STOP <sup>4</sup>
6									REM/LOC <sup>4</sup>
7									EDS start signal 1
8									Soak stop
9									RUN/STOP <sup>4</sup>
10									EDS start signal 1
11									Soak stop
12									RUN/STOP <sup>4</sup>
13									EDS start signal 1
14									Soak stop
15									RUN/STOP <sup>4</sup>
16									Interlock release
17	Interlock release		AUTO/MAN <sup>4</sup>		REM/LOC <sup>4</sup>		EDS start signal 1	Soak stop	
18	Interlock release		AUTO/MAN <sup>4</sup>		REM/LOC <sup>4</sup>		EDS start signal 1	Soak stop	
19	Interlock release		AUTO/MAN <sup>4</sup>		REM/LOC <sup>4</sup>		EDS start signal 1	Soak stop	
20	Interlock release		AUTO/MAN <sup>4</sup>		REM/LOC <sup>4</sup>		EDS start signal 1	Soak stop	
21	Interlock release		AUTO/MAN <sup>4</sup>		REM/LOC <sup>4</sup>		EDS start signal 1	Soak stop	
22	Interlock release		AUTO/MAN <sup>4</sup>		REM/LOC <sup>4</sup>		EDS start signal 1	Soak stop	
23	Interlock release		AUTO/MAN <sup>4</sup>		REM/LOC <sup>4</sup>		EDS start signal 1	Soak stop	
24	Interlock release		AUTO/MAN <sup>4</sup>		REM/LOC <sup>4</sup>		EDS start signal 1	Soak stop	
25	Interlock release		AUTO/MAN <sup>4</sup>		REM/LOC <sup>4</sup>		EDS start signal 1	Soak stop	
26	Memory area transfer (1, 2) <sup>1</sup>	Area set <sup>2</sup>	Interlock release	RUN/STOP <sup>4</sup>	AUTO/MAN <sup>4</sup>	REM/LOC <sup>4</sup>	Operation mode <sup>3</sup>		
27	Memory area transfer (1 to 8) <sup>1</sup>			Area set <sup>2</sup>	Operation mode <sup>3</sup>				
28	Memory area transfer (1, 2) <sup>1</sup>	Area set <sup>2</sup>	Interlock release	RUN/STOP <sup>4</sup>	AUTO/MAN <sup>4</sup>	REM/LOC <sup>4</sup>	EDS start signal 1	EDS start signal 2	
29	EDS start signal 1	EDS start signal 2	Interlock release	RUN/STOP <sup>4</sup>	AUTO/MAN <sup>4</sup>	REM/LOC <sup>4</sup>	Operation mode <sup>3</sup>		

RUN/STOP: RUN/STOP transfer (Contact closed: RUN)  
 AUTO/MAN: Auto/Manual transfer (Contact closed: Manual mode)  
 REM/LOC: Remote/Local transfer (Contact closed: Remote mode)  
 Interlock release (Contact closed: Interlock release)  
 EDS start signal 1 (Contact closed: EDS start signal ON [for disturbance 1])  
 EDS start signal 2 (Contact closed: EDS start signal ON [for disturbance 2])  
 Soak stop (Contact closed: Soak stop)

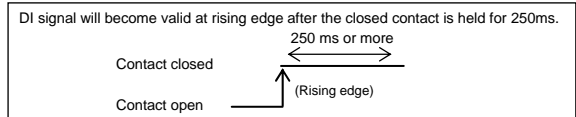

### <sup>1</sup> Memory area transfer

	Memory area number							
	1	2	3	4	5	6	7	8
DI1	x	-	x	-	x	-	x	-
DI2	x	x	-	-	x	x	-	-
DI3	x	x	x	x	-	-	-	-

<sup>2</sup> Area set becomes invalid prior to factory shipment.

### <sup>3</sup> Operation mode transfer

	Operation mode			
	Unused	Monitor	Monitor + Event function	Control
DI5 (DI7)	x	-	x	-
DI6 (DI8)	x	x	-	-

### <sup>4</sup> Actual device states (AUTO/MAN, REM/LOC, RUN/STOP)

	DI-switched state	Communication-switched state	Actual device state
Auto/Manual transfer <sup>a</sup> (AUTO/MAN)	Manual (Contact closed)	Manual → Auto Auto → Manual	Manual mode
	Auto (Contact open)	Manual → Auto Auto → Manual	Auto mode
Remote/Local transfer <sup>a</sup> (REM/LOC)	Remote (Contact closed)	Remote → Local Local → Remote	Remote mode
	Local (Contact open)	Remote → Local Local → Remote	Local mode
RUN/STOP <sup>b</sup>	RUN (Contact closed)	STOP → RUN RUN → STOP	RUN STOP
	STOP (Contact open)	STOP → RUN	STOP

<sup>a</sup> Device state when AUTO/MAN or REM/LOC assigned to DI is set so that the Z-TIO module and Z-DIO module are linked using the Master-slave mode of the Z-TIO module.

<sup>b</sup> STOP of RUN/STOP switching is given priority regardless of communication or DI switching.

## ● DO assignment table

[DO1 to DO4]

Set value	DO1	DO2	DO3	DO4
0	No assignment			
1	DO1 manual output	DO2 manual output	DO3 manual output	DO4 manual output
2	Event 1 comprehensive output <sup>1</sup>	Event 2 comprehensive output <sup>2</sup>	Event 3 comprehensive output <sup>3</sup>	Event 4 comprehensive output <sup>4</sup>
3	Event 1 (CH1)	Event 2 (CH1)	Event 3 (CH1)	Event 4 (CH1)
4	Event 1 (CH2)	Event 2 (CH2)	Event 3 (CH2)	Event 4 (CH2)
5	Event 1 (CH3)	Event 2 (CH3)	Event 3 (CH3)	Event 4 (CH3)
6	Event 1 (CH4)	Event 2 (CH4)	Event 3 (CH4)	Event 4 (CH4)
7	Event 1 (CH1)	Event 1 (CH2)	Event 1 (CH3)	Event 1 (CH4)
8	Event 2 (CH1)	Event 2 (CH2)	Event 2 (CH3)	Event 2 (CH4)
9	Event 3 (CH1)	Event 3 (CH2)	Event 3 (CH3)	Event 3 (CH4)
10	Event 4 (CH1)	Event 4 (CH2)	Event 4 (CH3)	Event 4 (CH4)
11	HBA (CH1)	HBA (CH2)	HBA (CH3)	HBA (CH4)
12	Burnout status (CH1)	Burnout status (CH2)	Burnout status (CH3)	Burnout status (CH4)
13	Temperature rise completion <sup>5</sup>	HBA comprehensive output <sup>6</sup>	Burnout state comprehensive output <sup>7</sup>	DO4 manual output

[DO5 to DO8]

Set value	DO5	DO6	DO7	DO8
0	No assignment			
1	DO5 manual output	DO6 manual output	DO7 manual output	DO8 manual output
2	Event 1 comprehensive output <sup>1</sup>	Event 2 comprehensive output <sup>2</sup>	Event 3 comprehensive output <sup>3</sup>	Event 4 comprehensive output <sup>4</sup>
3	Event 1 (CH1)	Event 2 (CH1)	Event 3 (CH1)	Event 4 (CH1)
4	Event 1 (CH2)	Event 2 (CH2)	Event 3 (CH2)	Event 4 (CH2)
5	Event 1 (CH3)	Event 2 (CH3)	Event 3 (CH3)	Event 4 (CH3)
6	Event 1 (CH4)	Event 2 (CH4)	Event 3 (CH4)	Event 4 (CH4)
7	Event 1 (CH1)	Event 1 (CH2)	Event 1 (CH3)	Event 1 (CH4)
8	Event 2 (CH1)	Event 2 (CH2)	Event 2 (CH3)	Event 2 (CH4)
9	Event 3 (CH1)	Event 3 (CH2)	Event 3 (CH3)	Event 3 (CH4)
10	Event 4 (CH1)	Event 4 (CH2)	Event 4 (CH3)	Event 4 (CH4)
11	HBA (CH1)	HBA (CH2)	HBA (CH3)	HBA (CH4)
12	Burnout status (CH1)	Burnout status (CH2)	Burnout status (CH3)	Burnout status (CH4)
13	Temperature rise completion <sup>5</sup>	HBA comprehensive output <sup>6</sup>	Burnout state comprehensive output <sup>7</sup>	DO8 manual output

<sup>1</sup> Logical OR of Event 1 (ch1 to ch4)<sup>2</sup> Logical OR of Event 2 (ch1 to ch4)<sup>3</sup> Logical OR of Event 3 (ch1 to ch4)<sup>4</sup> Logical OR of Event 4 (ch1 to ch4)<sup>5</sup> Temperature rise completion status (ON when temperature rise completion occurs for all channels for which event 3 is set to temperature rise completion.)<sup>6</sup> Logical OR of HBA (ch1 to ch4)<sup>7</sup> Logical OR of burnout state (ch1 to ch4)

### 8.3 Memory Area Data Items

The register addresses, 4000H to 453FH are used for checking and changing each set value belonging to the memory area.

No.	Name	Register address		Number of data items	Attribute	Data range	Factory set value
		HEX	DEC				
1	Setting memory area number	4000	16384	64	R/W	1 to 8 Use to select memory area number.	1
2	Event 1 set value	4040	16448	64	R/W	Deviation action, Deviation action between channels, Temperature rise completion range: –Input span to +Input span	50
3	Event 2 set value	4080	16512	64	R/W	Process action, SV action: Input scale low to Input scale high MV action: –5.0 to +105.0 %	50
4	Event 3 set value	40C0	16576	64	R/W	If the Event type corresponds to “0: None,” set to RO (Only reading data is possible). When temperature rise completion is selected at Event 3 action type.	50
5	Event 4 set value	4100	16640	64	R/W	If Event 4 corresponds to “9: Control loop break alarm (LBA),” the Event 4 set value becomes RO (Only reading data is possible).	50
6	Control loop break alarm (LBA) time	4140	16704	64	R/W	0 to 7200 seconds (0: Unused) If Event 4 is other than “9: Control loop break alarm (LBA),” set to RO (Only reading data is possible).	480
7	LBA deadband	4180	16768	64	R/W	0 (0.0) to Input span If Event 4 is other than “9: Control loop break alarm (LBA),” set to RO (Only reading data is possible).	0 (0.0)
8	Set value (SV)	41C0	16832	64	R/W	Setting limiter (low) to Setting limiter (high)	TC/RTD: 0 °C [°F] V/I: 0.0 %
9	Proportional band [heat-side] ◆	4200	16896	64	R/W	TC/RTD inputs: 0 (0.0) to Input span (Unit: °C [°F]) Varies with the setting of the decimal point position selection. Voltage (V)/current (I) inputs: 0.0 to 1000.0 % of Input span 0 (0.0): ON/OFF action ON/OFF action for both heat and cool actions in case of a heat/cool control type.	TC/RTD: 30 V/I: 30.0

Continued on the next page.

Continued from the previous page.

No.	Name	Register address		Number of data items	Attribute	Data range	Factory set value
		HEX	DEC				
10	Integral time [heat-side] ◆	4240	16960	64	R/W	PID control or heat/cool PID control: 0 to 3600 seconds or 0.0 to 1999.9 seconds (0, 0.0: PD action) Position proportioning control: 1 to 3600 seconds or 0.1 to 1999.9 seconds Varies with the setting of the integral/derivative time decimal point position selection.	240
11	Derivative time [heat-side] ◆	4280	17024	64	R/W	0 to 3600 seconds or 0.0 to 1999.9 seconds (0, 0.0: PI action) Varies with the setting of the integral/derivative time decimal point position selection.	60
12	Control response parameter ◆	42C0	17088	64	R/W	0: Slow 1: Medium 2: Fast [P or PD action: 2 (Fast) fixed]	PID control, Position proportioni ng control: 0 Heat/cool PID control: 2
13	Proportional band [cool-side] ◆	4300	17152	64	R/W	TC/RTD inputs: 1 (0.1) to Input span (Unit: °C [°F]) Varies with the setting of the decimal point position selection. Voltage (V)/current ( I ) inputs: 0.1 to 1000.0 % of Input span If control is other than heat/cool PID control, set to RO (Only reading data is possible).	TC/RTD: 30 V/I: 30.0
14	Integral time [cool-side] ◆	4340	17216	64	R/W	0 to 3600 seconds or 0.0 to 1999.9 seconds (0, 0.0: PD action) Varies with the setting of the integral/derivative time decimal point position selection. If control is other than heat/cool PID control, set to RO (Only reading data is possible).	240

Continued on the next page.

## 8. COMMUNICATION DATA LIST

Continued from the previous page.

No.	Name	Register address		Number of data items	Attribute	Data range	Factory set value
		HEX	DEC				
15	Derivative time [cool-side] ◆	4380	17280	64	R/W	0 to 3600 seconds or 0.0 to 1999.9 seconds (0, 0.0: PI action) Varies with the setting of the integral/derivative time decimal point position selection. If control is other than heat/cool PID control, set to RO (Only reading data is possible).	60
16	Overlap/Deadband ◆	43C0	17344	64	R/W	TC/RTD inputs: –Input span to +Input span (Unit:°C [°F]) Voltage (V)/current ( I ) inputs: –100.0 to +100.0 % of Input span Minus (–) setting results in overlap. However, the overlapping range is within the proportional range. If control is other than heat/cool PID control, set to RO (Only reading data is possible).	0
17	Manual reset	4400	17408	64	R/W	–100.0 to +100.0 % If the integral function is valid, set to RO (Only reading data is possible). When integral action (heating or cooling side) is zero, manual reset value is added to the control output.	0.0
18	Setting change rate limiter (up)	4440	17472	64	R/W	0 (0.0) to Input span/unit time * 0 (0.0): Unused	0 (0.0)
19	Setting change rate limiter (down)	4480	17536	64	R/W	* Unit time: 60 seconds (factory set value)	0 (0.0)
20	Area soak time	44C0	17600	64	R/W	0 minutes 00 seconds to 199 minutes 59 seconds: 0 to 11999 seconds 0 hours 00 minutes to 99 hours 59 minutes: 0 to 5999 minutes Data range of Area soak time can be selected on the Soak time unit.	0
21	Link area number	4500	17664	64	R/W	0 to 8 (0: No link)	0



## 8.4 COM-JL Communication Data Items

The register addresses, FA00H (64000) or more are used for checking and changing each set value of the COM-JL.

 : The value of this item should always be set to 4 (Z-TIO/Z-DIO module). If changed, malfunction may result.

♣ These items become valid by turning off the power of the COM-JL once, and then turning it on again after the settings are changed.

★ This setting (factory set value: 64) causes each address to be shifted by 64 for each communication item in the SRZ (Z-TIO/Z-DIO module) Communication Data and Memory Area Data. **Therefore, exercise sufficient care if you change the setting as the data mappings will also change.**

No.	Name	Register address		Number of data items	Attribute	Data range	Factory set value
		HEX	DEC				
—	Unused	FA00 ⋮ FA07	64000 ⋮ 64007	—	—	—	—
1	COM-JL error code	FA08	64008	1	RO	Bit data b0: Memory backup error b1: RAM error b2: Controller configuration error b3: Unused b4: Ethernet hardware error b5 to b15: Unused Data 0: OFF 1: ON [Decimal number: 0 to 23]	—
—	Unused	FA09	64009	—	—	—	—
2	Number of connected controller in controller communication	FA0A	64010	1	RO	0 to 31	—
3	Number of connected channel in controller communication	FA0B	64011	1	RO	0 to 128	—
4	Action mode selection ♣	FA0C	64012	1	R/W	Bit data b0: Address setting * 0: Continuous setting 1: Free setting b1 to b15: Unused [Decimal number: 0 to 1]	bit 0: 1 bit 1 to 15: 0 [Decimal number: 1]
5	Number of connectable controller channels ♣ ★	FA0D	64013	1	R/W	1 to 128	64

\* There are two address settings for the controller (SRZ) connecting to the COM-JL: continuous setting and free setting.

- For the continuous setting (factory set value), consecutive numbers starting from 1 are set to each controller.
- Free settings can be made in the range of 1 to 32.

Continued on the next page.

8. COMMUNICATION DATA LIST

Continued from the previous page.

No.	Name	Register address		Number of data items	Attribute	Data range	Factory set value
		HEX	DEC				
6	Transmission wait time of controller communication	FA0E	64014	1	R/W	0 to 100 ms	0
7	Backup memory state monitor	FA0F	64015	1	RO	0: The content of the backup memory does not coincide with that of the RAM. 1: The content of the backup memory coincides with that of the RAM	—
—	Unused	FA10 ⋮ FA27	64016 ⋮ 64039	—	—	—	—
8	No. 1 Controller type	FA28	64040	1	R/W	0 to 65534 4: Z-TIO/Z-DIO module	4
9	No. 2 Controller type	FA29	64041	1	R/W	0 to 65534 4: Z-TIO/Z-DIO module	4
10	No. 3 Controller type	FA2A	64042	1	R/W	0 to 65534 4: Z-TIO/Z-DIO module	4
11	No. 4 Controller type	FA2B	64043	1	R/W	0 to 65534 4: Z-TIO/Z-DIO module	4
12	No. 5 Controller type	FA2C	64044	1	R/W	0 to 65534 4: Z-TIO/Z-DIO module	4
13	No. 6 Controller type	FA2D	64045	1	R/W	0 to 65534 4: Z-TIO/Z-DIO module	4
14	No. 7 Controller type	FA2E	64046	1	R/W	0 to 65534 4: Z-TIO/Z-DIO module	4
15	No. 8 Controller type	FA2F	64047	1	R/W	0 to 65534 4: Z-TIO/Z-DIO module	4
16	No. 9 Controller type	FA30	64048	1	R/W	0 to 65534 4: Z-TIO/Z-DIO module	4
17	No. 10 Controller type	FA31	64049	1	R/W	0 to 65534 4: Z-TIO/Z-DIO module	4
18	No. 11 Controller type	FA32	64050	1	R/W	0 to 65534 4: Z-TIO/Z-DIO module	4
19	No. 12 Controller type	FA33	64051	1	R/W	0 to 65534 4: Z-TIO/Z-DIO module	4
20	No. 13 Controller type	FA34	64052	1	R/W	0 to 65534 4: Z-TIO/Z-DIO module	4
21	No. 14 Controller type	FA35	64053	1	R/W	0 to 65534 4: Z-TIO/Z-DIO module	4
22	No. 15 Controller type	FA36	64054	1	R/W	0 to 65534 4: Z-TIO/Z-DIO module	4
23	No. 16 Controller type	FA37	64055	1	R/W	0 to 65534 4: Z-TIO/Z-DIO module	4

Continued on the next page.

Continued from the previous page.

No.	Name	Register address		Number of data items	Attribute	Data range	Factory set value
		HEX	DEC				
24	No. 17 Controller type	FA38	64056	1	R/W	0 to 65534 4: Z-TIO/Z-DIO module	4
25	No. 18 Controller type	FA39	64057	1	R/W	0 to 65534 4: Z-TIO/Z-DIO module	4
26	No. 19 Controller type	FA3A	64058	1	R/W	0 to 65534 4: Z-TIO/Z-DIO module	4
27	No. 20 Controller type	FA3B	64059	1	R/W	0 to 65534 4: Z-TIO/Z-DIO module	4
28	No. 21 Controller type	FA3C	64060	1	R/W	0 to 65534 4: Z-TIO/Z-DIO module	4
29	No. 22 Controller type	FA3D	64061	1	R/W	0 to 65534 4: Z-TIO/Z-DIO module	4
30	No. 23 Controller typ	FA3E	64062	1	R/W	0 to 65534 4: Z-TIO/Z-DIO module	4
31	No. 24 Controller type	FA3F	64063	1	R/W	0 to 65534 4: Z-TIO/Z-DIO module	4
32	No. 25 Controller type	FA40	64064	1	R/W	0 to 65534 4: Z-TIO/Z-DIO module	4
33	No. 26 Controller type	FA41	64065	1	R/W	0 to 65534 4: Z-TIO/Z-DIO module	4
34	No. 27 Controller type	FA42	64066	1	R/W	0 to 65534 4: Z-TIO/Z-DIO module	4
35	No. 28 Controller type	FA43	64067	1	R/W	0 to 65534 4: Z-TIO/Z-DIO module	4
36	No. 29 Controller type	FA44	64068	1	R/W	0 to 65534 4: Z-TIO/Z-DIO module	4
37	No. 30 Controller type	FA45	64069	1	R/W	0 to 65534 4: Z-TIO/Z-DIO module	4
38	No. 31 Controller type	FA46	64070	1	R/W	0 to 65534 4: Z-TIO/Z-DIO module	4
—	Unused	FA47	64071	—	—	—	—
39	No. 1 Controller state	FA48	64072	1	RO	Bit data b0: Presence or absence of controller b1: Presence or absence of abnormal respomse b2 to b15: Unused Data 0: Absence 1: Presence [Decimal number: 0 to 3]	—
40	No. 2 Controller state	FA49	64073	1	RO		—
41	No. 3 Controller state	FA4A	64074	1	RO		—
42	No. 4 Controller state	FA4B	64075	1	RO		—
43	No. 5 Controller state	FA4C	64076	1	RO		—
44	No. 6 Controller state	FA4D	64077	1	RO		—
45	No. 7 Controller state	FA4E	64078	1	RO		—
46	No. 8 Controller state	FA4F	64079	1	RO		—

Continued on the next page.

8. COMMUNICATION DATA LIST

Continued from the previous page.

No.	Name	Register address		Number of data items	Attribute	Data range	Factory set value	
		HEX	DEC					
47	No. 9 Controller state	FA50	64080	1	RO	Bit data b0: Presence or absence of controller b1: Presence or absence of abnormal resepomse b2 to b15: Unused Data 0: Absence 1: Presence [Decimal number: 0 to 3]	—	
48	No. 10 Controller state	FA51	64081	1	RO		—	
49	No. 11 Controller state	FA52	64082	1	RO		—	
50	No. 12 Controller state	FA53	64083	1	RO		—	
51	No. 13 Controller state	FA54	64084	1	RO		—	
52	No. 14 Controller state	FA55	64085	1	RO		—	
53	No. 15 Controller state	FA56	64086	1	RO		—	
54	No. 16 Controller state	FA57	64087	1	RO		—	
55	No. 17 Controller state	FA58	64088	1	RO		—	
56	No. 18 Controller state	FA59	64089	1	RO		—	
57	No. 19 Controller state	FA5A	64090	1	RO		—	
58	No. 20 Controller state	FA5B	64091	1	RO		—	
59	No. 21 Controller state	FA5C	64092	1	RO		—	
60	No. 22 Controller state	FA5D	64093	1	RO		—	
61	No. 23 Controller state	FA5E	64094	1	RO		—	
62	No. 24 Controller state	FA5F	64095	1	RO		—	
63	No. 25 Controller state	FA60	64096	1	RO		—	
64	No. 26 Controller state	FA61	64097	1	RO		—	
65	No. 27 Controller state	FA62	64098	1	RO		—	
66	No. 28 Controller state	FA63	64099	1	RO		—	
67	No. 29 Controller state	FA64	64100	1	RO		—	
68	No. 30 Controller state	FA65	64101	1	RO		—	
69	No. 31 Controller state	FA66	64102	1	RO		—	
—	Unused	FA67	64103	—	—		—	—

Continued on the next page.

Continued from the previous page.

No.	Name	Register address		Number of data items	Attribute	Data range	Factory set value
		HEX	DEC				
70	No. 1 Controller address	FA68	64104	1	R/W	1 to 32 * 0: There is no connection controller	1
71	No. 2 Controller address	FA69	64105	1	R/W	1 to 32 * 0: There is no connection controller	2
72	No. 3 Controller address	FA6A	64106	1	R/W	1 to 32 * 0: There is no connection controller	3
73	No. 4 Controller address	FA6B	64107	1	R/W	1 to 32 * 0: There is no connection controller	4
74	No. 5 Controller address	FA6C	64108	1	R/W	1 to 32 * 0: There is no connection controller	5
75	No. 6 Controller address	FA6D	64109	1	R/W	1 to 32 * 0: There is no connection controller	6
76	No. 7 Controller address	FA6E	64110	1	R/W	1 to 32 * 0: There is no connection controller	7
77	No. 8 Controller address	FA6F	64111	1	R/W	1 to 32 * 0: There is no connection controller	8
78	No. 9 Controller address	FA70	64112	1	R/W	1 to 32 * 0: There is no connection controller	9
79	No. 10 Controller address	FA71	64113	1	R/W	1 to 32 * 0: There is no connection controller	10
80	No. 11 Controller address	FA72	64114	1	R/W	1 to 32 * 0: There is no connection controller	11
81	No. 12 Controller address	FA73	64115	1	R/W	1 to 32 * 0: There is no connection controller	12
82	No. 13 Controller address	FA74	64116	1	R/W	1 to 32 * 0: There is no connection controller	13
83	No. 14 Controller address	FA75	64117	1	R/W	1 to 32 * 0: There is no connection controller	14
84	No. 15 Controller address	FA76	64118	1	R/W	1 to 32 * 0: There is no connection controller	15
85	No. 16 Controller address	FA77	64119	1	R/W	1 to 32 * 0: There is no connection controller	16
86	No. 17 Controller address	FA78	64120	1	R/W	1 to 32 * 0: There is no connection controller	17
87	No. 18 Controller address	FA79	64121	1	R/W	1 to 32 * 0: There is no connection controller	18
88	No. 19 Controller address	FA7A	64122	1	R/W	1 to 32 * 0: There is no connection controller	19
89	No. 20 Controller address	FA7B	64123	1	R/W	1 to 32 * 0: There is no connection controller	20
90	No. 21 Controller address	FA7C	64124	1	R/W	1 to 32 * 0: There is no connection controller	21

\* Set the controller address in the following range.

- Z-TIO module: 1 to 16 (Address setting switch: 0 to F)
- Z-DIO module: 17 to 32 (Address setting switch: 0 to F)

Continued on the next page.

Continued from the previous page.

No.	Name	Register address		Number of data items	Attribute	Data range	Factory set value
		HEX	DEC				
91	No. 22 Controller address	FA7D	64125	1	R/W	1 to 32 * 0: There is no connection controller	22
92	No. 23 Controller address	FA7E	64126	1	R/W	1 to 32 * 0: There is no connection controller	23
93	No. 24 Controller address	FA7F	64127	1	R/W	1 to 32 * 0: There is no connection controller	24
94	No. 25 Controller address	FA80	64128	1	R/W	1 to 32 * 0: There is no connection controller	25
95	No. 26 Controller address	FA81	64129	1	R/W	1 to 32 * 0: There is no connection controller	26
96	No. 27 Controller address	FA82	64130	1	R/W	1 to 32 * 0: There is no connection controller	27
97	No. 28 Controller address	FA83	64131	1	R/W	1 to 32 * 0: There is no connection controller	28
98	No. 29 Controller address	FA84	64132	1	R/W	1 to 32 * 0: There is no connection controller	29
99	No. 30 Controller address	FA85	64133	1	R/W	1 to 32 * 0: There is no connection controller	30
100	No. 31 Controller address	FA86	64134	1	R/W	1 to 32 * 0: There is no connection controller	31
101	Automatic acquisition of controller address <sup>1</sup>	FA87	64135	1	R/W	0: Do not execute the automatic acquisition 1: Execute the automatic acquisition	0

\* Set the controller address in the following range.

- Z-TIO module: 1 to 16 (Address setting switch: 0 to F)
- Z-DIO module: 17 to 32 (Address setting switch: 0 to F)

<sup>1</sup> The controller address automatic acquisition set “1: Execute the automatic acquisition,” performs the automatic acquisition of the controller address by turning on the power again. Automatically reverts to “0: Do not execute the automatic acquisition” after automatic acquisition ends.

# 9. TROUBLESHOOTING

---

This section explains probable causes and treatment procedures if any abnormality occurs in the instrument. For any inquiries, please contact RKC sales office or the agent, to confirm the specifications of the product.

If it is necessary to replace a device, always strictly observe the warnings below.



## WARNING

- To prevent electric shock or instrument failure, always turn off the system power before replacing the instrument.
- To prevent electric shock or instrument failure, always turn off the power before mounting or removing the instrument.
- To prevent electric shock or instrument failure, do not turn on the power until all the wiring is completed.
- To prevent electric shock or instrument failure, do not touch the inside of the instrument.
- All wiring must be performed by authorized personnel with electrical experience in this type of work.

## CAUTION

**Do not separate the mainframe from the terminal base with the power turned on. If so, instrument failure may result.**

### ■ COM-JL

Problem	Probable cause	Solution
RUN lamp does not light up	Power not being supplied	Check external breaker etc.
	Appropriate power supply voltage not being supplied	Check the power supply and supply the normal power
	Power supply terminal contact defect	Retighten the terminals
	Power supply section defect	Replace COM-JL
RUN lamp flashes rapidly	Data collection just after the power is turned on	After data collection, the lamp goes on, if normal
RUN lamp flashes slowly	Memory backup error	Turn on the power again
		Write setting value once again
	Controller configuration error Disconnection of the controller connection	Confirm the controller connection condition and connect correctly
	Input error The IP address was not normally set by DIP switch	Confirm the IP address setting and set this correctly
FAIL lamp is lit	Appropriate power supply voltage not being supplied	Check the power supply and supply the normal power
	Hardware error	Replace COM-JL

### ■ Communication

Problem	Probable cause	Solution
<ul style="list-style-type: none"> <li>• Can not set the IP address</li> <li>• The client and the server are not in the connected state (the client cannot recognize the server)</li> </ul>	The IP address class and subnet mask of the client do not coincide with those of the server	Coincide the IP address class and subnet mask of the client with those of the server
	The network related software was started before the connection of the Ethernet cable	First connect the Ethernet cable and then start the network related software
No response	Wrong connection, no connection or disconnection of the communication cable	Confirm the connection method or condition and connect correctly
	Breakage, wrong wiring, or imperfect contact of the communication cable	Confirm the wiring or connector and repair or replace the wrong one
	Wrong IP address setting	Confirm the settings and set them correctly
	There is length of query message exceeds set range	
	The number of data points is not twice the specified number of data points at the time of data write	

Continued on the next page.



Continued from the previous page.

<b>Problem</b>	<b>Probable cause</b>	<b>Solution</b>
Error code: 01H	Function code error (Specifying nonexistent function code)	Confirm the function code
Error code: 02H	When the mismatched address is specified	Confirm the address of holding register
Error code: 03H	When the data written exceeds the setting range	Confirm the setting data
	When the number of specified data points was out of a range of 1 to 125 during data read (function code: 03H)	
	When the number of specified data points was out of a range of 1 to 123 during data write (function code: 10H)	
	When the number of specified data points was out of a range of 1 to 118 during data read/write (function code: 17H)	
Error code: 04H	State under which the server (COM-JL) cannot normally respond [An error occurred in the server (COM-JL)]	Remove the cause of the error occurring in the server (COM-JL).
Error code: 06H	State under which the server (COM-JL) cannot immediately respond [The server (COM-JL) is being initialized]	Conduct communication again after initialization is finished.

# 10. SPECIFICATIONS

---

## ■ Ethernet communication

<b>Physical layer:</b>	Ethernet 10BASE-T/100BASE-TX automatic recognition
<b>Application layer:</b>	Modbus/TCP
<b>Communication data:</b>	Based on Modbus message format
<b>Connector type:</b>	RJ-45

## ■ Controller communication

<b>Interface:</b>	Based on RS-485, EIA standard
<b>Protocol:</b>	Modbus-RTU
<b>Synchronous method:</b>	Start/stop synchronous type
<b>Connection method:</b>	2-wire system, half-duplex multi-drop connection
<b>Communication speed:</b>	9600 bps, 19200 bps, 38400 bps
<b>Data bit configuration:</b>	Start bit: 1 Data bit: 8 Parity bit: Without Stop bit: 1
<b>Maximum connections:</b>	31 controllers (SRZ module) * * A combined total of up to 31 Z-TIO and Z-DIO modules can be connected in the SRZ. However, the maximum joinable number of functional modules of the same type is 16.
<b>Connection method:</b>	Terminals
<b>Termination resistor:</b>	Built-in terminal base of COM-JL [ON/OFF select with switch (120 Ω)]

## ■ Self-diagnostic function

<b>Hardware error:</b>	Display: FAIL lamp ON
<b>Memory backup error:</b>	Display: RUN lamp flashes Status: 1 is set in bit 0 of COM-JL error code
<b>Configuration error (Can not recognize the controller):</b>	Display: RUN lamp flashes Status: 1 is set in bit 2 of COM-JL error code

### ■ General specifications

**Power supply voltage:** 21.6 to 26.4 V DC [Including power supply voltage variation]  
(Rating 24 V DC)

**Current consumption:** 110 mA max. (at 24 V DC)

**Rush current:** 12 A or less

**Insulation resistance:** Between communication terminal and grounding:  
20 MΩ or more at 500 V DC  
Between power supply terminal and grounding:  
20 MΩ or more at 500 V DC  
Between power supply terminal and communication terminal:  
20 MΩ or more at 500 V DC

**Withstand voltage:** See table shown below

Time: 1 min.	Grounding terminal	Power supply terminal
Grounding terminal		
Power supply terminal	600 V AC	
Communication terminal	600 V AC	600 V AC

**Power failure:** A power failure of 20 ms or less will not affect the control action.

**Memory backup:** Backed up by non-volatile memory  
Number of writing: Approx. 100,000 times  
Data storage period: Approx. 10 years

**Vibration:** Amplitude: < 1.5 mm (5 to 9 Hz)  
Acceleration: < 5 m/s<sup>2</sup> (9 to 150 Hz)  
Each direction of XYZ axes

**Shock:** Height 50 mm or less  
Each direction of XYZ axes (de-energized state)

**Allowable ambient temperature:**  
-10 to +50 °C

**Allowable ambient humidity:**  
5 to 95 %RH  
(Absolute humidity: MAX.W.C 29.3 g/m<sup>3</sup> dry air at 101.3 kPa)

**Installation environment conditions:**  
Indoor use  
Altitude up to 2000 m

**Operating environments** Avoid the following conditions when selecting the mounting location.

- Rapid changes in ambient temperature which may cause condensation.
- Corrosive or inflammable gases.
- Direct vibration or shock to the mainframe.
- Water, oil, chemicals, vapor or steam splashes.
- Excessive dust, salt or iron particles.
- Excessive induction noise, static electricity, magnetic fields or noise.
- Direct air flow from an air conditioner.
- Exposure to direct sunlight.
- Excessive heat accumulation.

**Weight:** Approx. 180 g

**Dimensions:** 30 × 125 × 109.5 mm (W × H × D)

■ **Standard**

**Safety standards:** UL: UL61010-1  
cUL: CAN/CSA-C22.2 No.61010-1

**CE marking:** LVD: EN61010-1  
EMC: EN61326-1

**RCM:** EN55011

The first edition: MAY 2007 [IMQ00]  
The second edition: DEC. 2015 [IMQ00]



HEADQUARTERS: 16-6, KUGAHARA 5-CHOME, OHTA-KU TOKYO 146-8515 JAPAN

PHONE: 03-3751-9799 (+81 3 3751 9799)

FAX: 03-3751-8585 (+81 3 3751 8585)

E-mail: [info@rkcinst.co.jp](mailto:info@rkcinst.co.jp)

Website: <http://www.rkcinst.com/>