Communication Converter

COM-E

[For LE100]

Instruction Manual

- MONITOUCH V6 series are products manufactured by Hakko Electronics Co., Ltd.
- The respective products of the programmable controller (PLC) are products manufactured by the respective companies.
- Other names of products or manufacturers used in this manual are trademarks or registered trademarks of the respective companies.

Thank you for purchasing this RKC product. In order to achieve maximum performance and ensure proper operation of your new instrument, carefully read all the instructions in this manual. Please place the manual in a convenient location for easy reference.

SYMBOLS

WARNING : This mark indicates precautions that must be taken if there is danger of electric shock, fire, etc., which could result in loss of life or injury.

CAUTION : This mark indicates that if these precautions and operating procedures are not taken, damage to the instrument may result.



: This mark indicates that all precautions should be taken for safe usage.



: This mark indicates important information on installation, handling and operating procedures.



: This mark indicates supplemental information on installation, handling and operating procedures.



: This mark indicates where additional information may be located.



WARNING

- An external protection device must be installed if failure of this instrument could result in damage to the instrument, equipment or injury to personnel.
- All wiring must be completed before power is turned on to prevent electric shock, fire or damage to instrument and equipment.
- This instrument must be used in accordance with the specifications to prevent fire or damage to instrument and equipment.
- This instrument is not intended for use in locations subject to flammable or explosive gases.
- Do not touch high-voltage connections such as power supply terminals, etc. to avoid electric shock.
- RKC is not responsible if this instrument is repaired, modified or disassembled by other than factory-approved personnel. Malfunction can occur and warranty is void under these conditions.

CAUTION

- This product is intended for use with industrial machines, test and measuring equipment. (It is not designed for use with medical equipment and nuclear energy.)
- This is a Class A instrument. In a domestic environment, this instrument may cause radio interference, in which case the user may be required to take additional measures.
- This instrument is protected from electric shock by reinforced insulation. Provide reinforced insulation between the wire for the input signal and the wires for instrument power supply, source of power and loads.
- Be sure to provide an appropriate surge control circuit respectively for the following:
 - If input/output or signal lines within the building are longer than 30 meters.
 - If input/output or signal lines leave the building, regardless the length.
- This instrument is designed for installation in an enclosed instrumentation panel. All high-voltage connections such as power supply terminals must be enclosed in the instrumentation panel to avoid electric shock by operating personnel.
- All precautions described in this manual should be taken to avoid damage to the instrument or equipment.
- All wiring must be in accordance with local codes and regulations.
- All wiring must be completed before power is turned on to prevent electric shock, instrument failure, or incorrect action.

The power must be turned off before repairing work for input break and output failure including replacement of sensor, contactor or SSR, and all wiring must be completed before power is turned on again.
- To prevent instrument damage or failure, protect the power line and the input/output lines from high currents with a protection device such as fuse, circuit breaker, etc.
- Prevent metal fragments or lead wire scraps from falling inside instrument case to avoid electric shock, fire or malfunction.
- Tighten each terminal screw to the specified torque found in the manual to avoid electric shock, fire or malfunction.
- For proper operation of this instrument, provide adequate ventilation for heat dispensation.
- Do not connect wires to unused terminals as this will interfere with proper operation of the instrument.
- Turn off the power supply before cleaning the instrument.
- Do not use a volatile solvent such as paint thinner to clean the instrument. Deformation or discoloration will occur. Use a soft, dry cloth to remove stains from the instrument.
- To avoid damage to instrument display, do not rub with an abrasive material or push front panel with a hard object.
- Do not connect modular connectors to telephone line.
- When high alarm with hold action/re-hold action is used for Event function, alarm does not turn on while hold action is in operation. Take measures to prevent overheating which may occur if the control device fails.

NOTICE

- This manual assumes that the reader has a fundamental knowledge of the principles of electricity, process control, computer technology and communications.
- The figures, diagrams and numeric values used in this manual are only for purpose of illustration.
- RKC is not responsible for any damage or injury that is caused as a result of using this instrument, instrument failure or indirect damage.
- RKC is not responsible for any damage and/or injury resulting from the use of instruments made by imitating this instrument.
- Periodic maintenance is required for safe and proper operation of this instrument. Some components have a limited service life, or characteristics that change over time.
- Every effort has been made to ensure accuracy of all information contained herein. RKC makes no warranty expressed or implied, with respect to the accuracy of the information. The information in this manual is subject to change without prior notice.
- No portion of this document may be reprinted, modified, copied, transmitted, digitized, stored, processed or retrieved through any mechanical, electronic, optical or other means without prior written approval from RKC.

CONTENTS

	Page
1. OUTLINE	1
1.1 Product Outline	1
1.2 Confirmation of the Model Code	3
1.3 Parts Description	4
2. SPECIFICATIONS	6
3. MOUNTING	10
3.1 Mounting Environment.....	10
3.2 Dimensions.....	11
3.3 Mounting the Mother Block.....	12
3.4 Mounting the Module Mainframe	14
3.5 Removing the Module Mainframe.....	14
4. WIRING	15
4.1 Wiring Cautions	15
4.2 Terminal Configuration	16
4.3 Connection	17
4.3.1 Connection to PLC	17
4.3.2 Connection to the LE100 and RKC temperature controller.....	23
4.3.3 Connection to the host computer	27
4.3.4 Connection to the operation panel	28
5. PLC COMMUNICATION.....	30
5.1 Rotary Switch Setting	30
5.2 PLC Setting	31
5.2.1 YOKOGAWA FA-M3 series.....	31
5.2.2 MITSUBISHI MELSEC A series (A, AnA, AnU types)/Q series/QnA series.....	32
5.2.3 OMRON SYSMAC CS1 series.....	33
5.3 The LE100 and RKC Temperature Controller Setting	34
5.4 Communication Data	35
5.4.1 Request command and data transfer	35
5.4.2 Communications status check.....	37
5.4.3 Caution for handling communication data.....	38

	Page
5.5 Communication Items List.....	39
5.5.1 Reference to communication items list.....	39
5.5.2 LE100	40
5.5.3 RKC temperature controller (REX-F400/700/900, CB100/400/500/700/900, SA200)	43
5.6 Table of Register Area Numbers vs. Register Numbers	45
6. HOST COMMUNICATION	49
6.1 Protocol.....	49
6.1.1 Communication data structure	49
6.1.2 Polling.....	50
6.1.3 Selecting.....	55
6.2 Communication Identifier List.....	58
6.2.1 LE100	58
6.2.2 RKC temperature controller (REX-F400/700/900, CB100/400/500/700/900, SA200)	60
7. USAGE EXAMPLE	61
7.1 Configuration Instrument	61
7.2 Handling Procedures	62
7.3 Connection of Each Instrument.....	63
7.4 Communication Items and Assignment of PLC Register	64
7.5 Setting in Each Instrument.....	65
7.6 Initial Setting	68
7.7 Data Setting	70
8. TROUBLESHOOTING	72
9. ASCII 7-BIT CODE TABLE.....	76

1. OUTLINE

This manual describes the specifications, mounting, wiring, connection, rotary switch setting and data details of the COM-E.

1.1 Product Outline

The COM-E-□□-02 communication converter (hereinafter called the COM-E) is a product to connect the Back Pressure Type Indicator LE100 with communication function or the RKC temperature controller with communication function and the programmable controller (PLC). When using the RKC temperature controller in reference to this specification of COM-E, the communication items are only measured value and set value.

Also, COM-E has the host communication port and the operation panel (MONITOUCH V6 series made by Hakko Electronics Co., Ltd) port as the additional function.

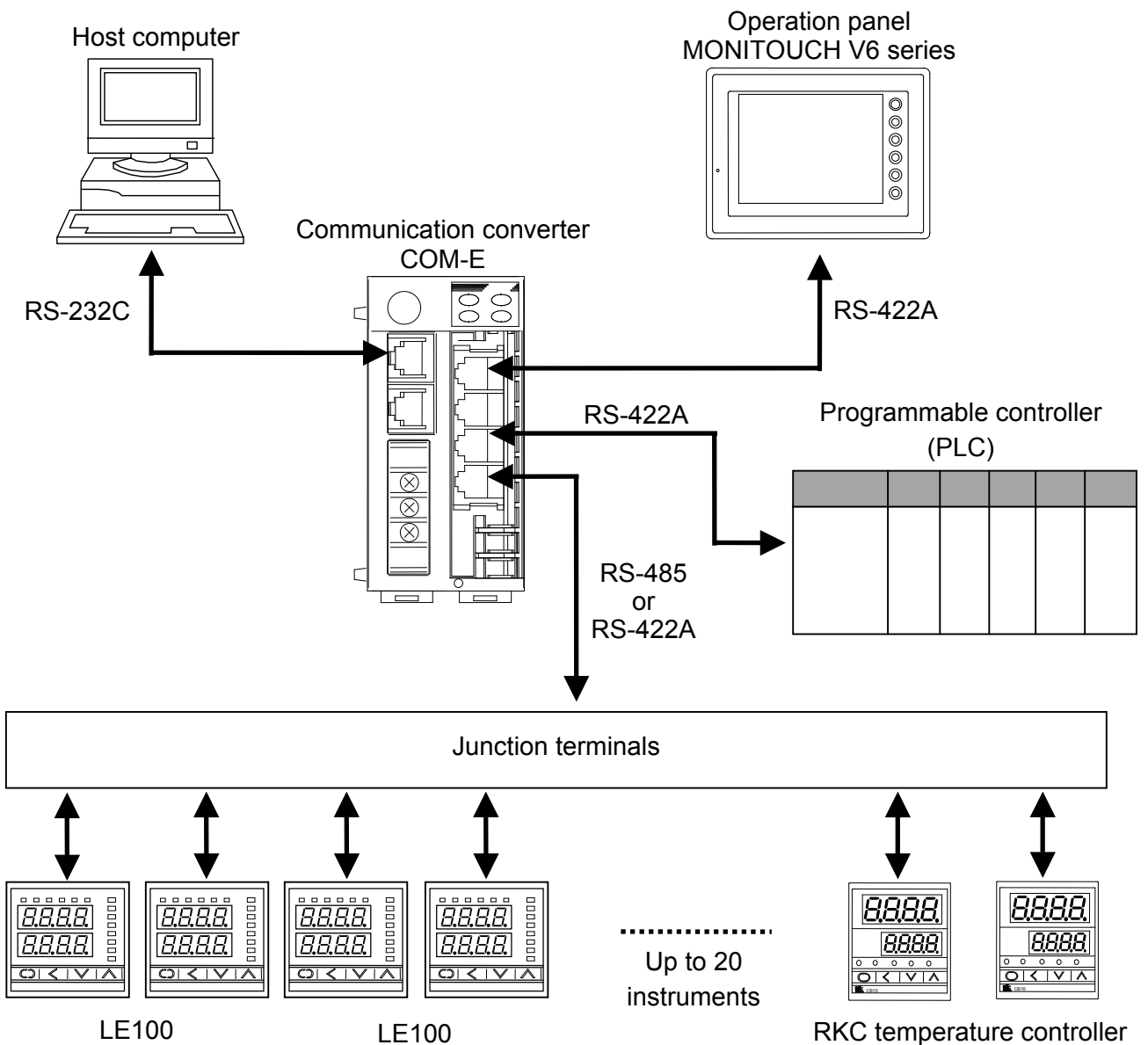



Fig.1-1 System configuration

■ **Communication port**

COM-E has the following four kinds of communication ports.

● **PLC communication port**

COM-E connects the **LE100** or the RKC temperature controller and PLC, and works as the communication protocol converter. The PLC can connect one **COM-E**, using modular connector.

 For a specification of connecting PLC, refer to the instruction manual for the used PLC.

● **The LE100 and RKC temperature controller communication port**

This is RKC standard communication port used in the **LE100** and RKC temperature controller. **COM-E** can connect the maximum twenty instruments in multi-drop wiring.

● **Host computer communication port**

Host computer to be connected to host communication port can monitor, operate and control the system.

The host computer can connect one **COM-E**, using modular connector.

● **Operation panel communication port**

COM-E connects the **LE100** or the RKC temperature controller and the operation panel, and works as the communication protocol converter. The operation panel can connect one **COM-E**, using modular connector.

 For the operation panel communication, refer to the instruction manual for the V6 series of Hakko Electronics.

1.2 Confirmation of the Model Code

When unpacking your new instrument, please confirm that the following products are included.
If the product you received is not the one ordered, please contact RKC sales office or the agent.

■ Communication converter

COM-E-□□-02 (24 V DC)
(1) (2)

(1) PLCs

- 01: YOKOGAWA PLC FA-M3 series
- 02: MITSUBISHI MELSEC A series (A, AnA, AnU type) / Q series / QnA series of PLCs
- 03: OMRON PLC SYSMAC CS1 series

(2) Corresponding to the RKC instrument

- 02: The Back Pressure Type Indicator **LE100**
The RKC temperature controller **REX-F400/700/900**
The RKC temperature controller **CB100/400/500/700/900**
The RKC temperature controller **SA200**



A model code label is attached to the left side of the **COM-E**.

■ Modular connector cables (Sold separately)

W-BF-01-□□□□

□□□□ are filled with cable length in mm. Please specify the length on your purchasing order. The standard length is 3000.

W-BF-01: Used to connect the LE100, the RKC temperature controller, PLC, or the operation panel.

■ Terminal converter (Sold separately: Hakko Electronics Co., Ltd)

TC485

The TC485 is a converting connector for connecting the operation panel.
It is used together with the modular connector cable (W-BF-01-□□□□).

■ Cable to connect the host computer

The customer is requested to prepare a communication cable (cable with connector) for the **COM-E** to be connected by the host computer.

1.3 Parts Description

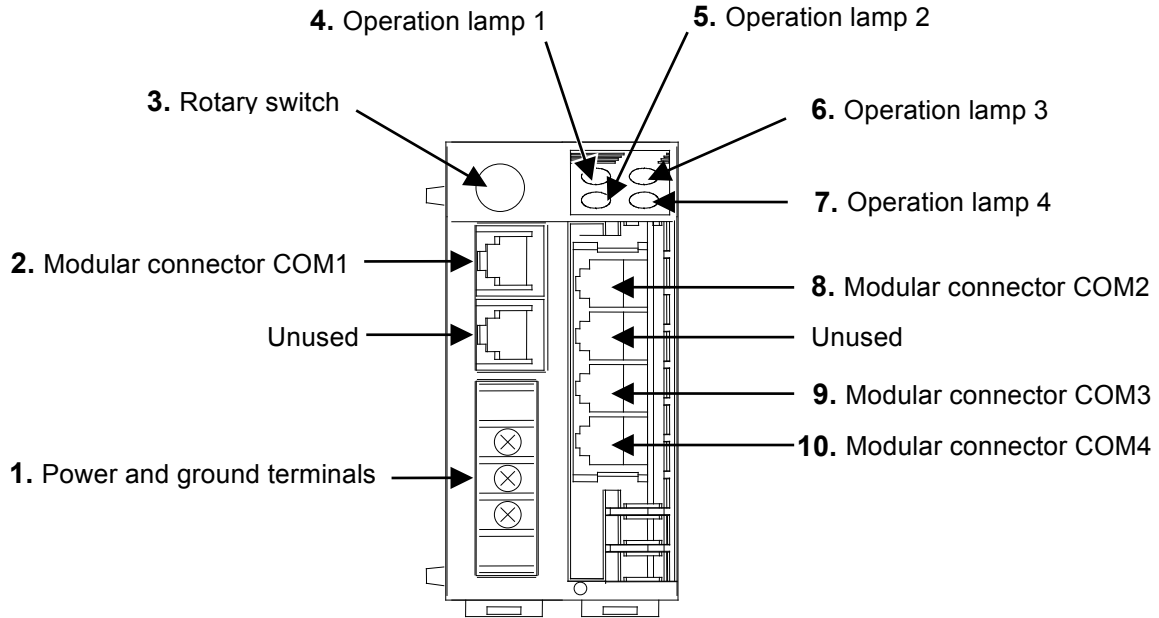

Fig.1-2 Front view

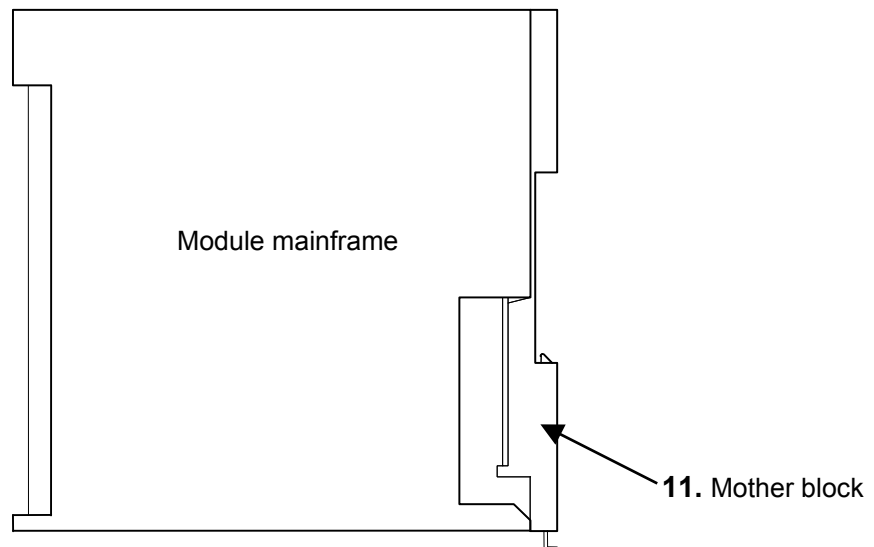

Fig.1-3 Side view

No.	Name	Description
1	Power and ground terminals	Power supply (24 V DC) and ground terminals
2	Modular connector COM1	Host communication port (for RS-232C)
3	Rotary switch	Register number selector of PLC
4	Operation lamp 1 (Yellow LED)	Flashing: Host communication is operating.
5	Operation lamp 2 (Yellow LED)	Flashing: Operation panel communication is operating.
6	Operation lamp 3 (Yellow LED) *	Flashing: PLC communication is operating.
7	Operation lamp 4 (Yellow LED) *	Flashing: The RKC instrument communication is operating.
8	Modular connector COM2	Operation panel communication port (for RS-422A)
9	Modular connector COM3	PLC communication port (for RS-422A)
10	Modular connector COM4	The LE100 or The RKC temperature controller communication port
11	Mother block	Module DIN rail mounting connector

* LED flashes on and off regardless of presence of junction of PLC and temperature controller as soon as the power is turned on.

2. SPECIFICATIONS

■ PLC communication

Communication interface: Based on RS-422A, EIA standard

Communication method: Four-wire system, multi-drop connection

Protocol: PLC standard communication

Synchronous method: Start-stop synchronous type

Communication speed: 9600 bps, 19200 bps (Factory set value: 19200 bps)
(Selectable)

It is necessary that connect the operation panel when the setting is changed.

Data bit configuration: Start bit: 1
Data bit: 8
Parity bit: Without or Even*
Stop bit: 1

* For OMRON PLC SYSMAC CS1 series

Communication code: ASCII 7-bit code

Number of connection: One PLC per **COM-E**

■ The LE100 or the RKC temperature controller communication

Communication interface: Based on EIA standard RS-485 or EIA standard RS-422A *
* RS-422A is only for **REX-F400/700/900**

Communication method: Two-wire system, multi-drop connection (RS-485)
Four-wire system, multi-drop connection (RS-422A)

Protocol: RKC standard communication
(Based on ANSI X 3.28 subcategories 2.5 and B1)

Synchronous method: Start/Stop synchronous type

Communication speed: 9600 bps, 19200 bps (Factory set value: 19200 bps)
(Selectable)

It is necessary that connect the operation panel when the setting is changed.

Data bit configuration: Start bit: 1
Data bit: 8
Parity bit: Without
Stop bit: 1

Communication code: ASCII 7-bit code

Number of connection: Up to 20 instruments including both LE100 and RKC temperature controllers per **COM-E**

■ Host communication

Communication interface:	Based on RS-232C, EIA standard
Communication method:	RS-232C point-to-point connection
Protocol:	Based on ANSI X3.28 subcategories 2.5 and B1 Polling/Selecting type
Error control:	Horizontal parity
Synchronous method:	Start-stop synchronous type
Communication speed:	9600 bps, 19200 bps (factory set value: 19200 bps) (Selectable) It is necessary that connect the operation panel when the setting is changed.
Data bit configuration:	Start bit: 1 Data bit: 8 Parity bit: Without Stop bit: 1
Block length:	128 bytes or less
Communication code:	ASCII 7-bit code
Control codes:	ENQ (05H), EOT (04H), STX (02H), ETB (17H), ETX (03H), ACK (06H), NAK (15H) Codes in brackets () are in hexadecimal.
Time out time:	3 seconds
Number of connection:	One host computer per COM-E
Signal voltage and Logic:	RS-232C

Signal voltage	Logic
+ 3V or more	0 (Space status)
- 3V or less	1 (Mark status)

■ Operation panel communication

Communication interface: Based on RS-422A, EIA standard

Communication method: Four-wire system, multi-drop connection

Protocol: Based on MITSUBISHI AnA communication protocol

Synchronous method: Start-stop synchronous type

Communication speed: 9600 bps, 19200 bps, 38400 bps (factory set value: 19200 bps)
(Selectable)

It is necessary that connect the operation panel when the setting is changed.

Data bit configuration: Start bit: 1
Data bit: 8
Parity bit: Without
Stop bit: 1

Communication code: ASCII 7-bit code

Number of connection: One operation panel per **COM-E**

■ Power supply

Power supply voltage: 21.6 to 26.4 V DC (Rating: 24 V DC)

Ripple noise: 10 % or less (peak to peak)

Current consumption: 85 mA max. (24 V DC)

■ Diagnostic functions

Check item: ROM/RAM check

Watchdog timer

If error occurs in self-diagnosis, the message is displayed on the operation panel display.

■ Data storage functions

Memory backup: Lithium battery for RAM backup, approximate 10 years life for data retention.

* However, the above life differs depending on the product storage period, and storage and operating environments.

■ Calendar functions

Precision:	Within ± 2.3 seconds per day
Setting method:	Time set with the operation panel screen
Display:	Western (Gregorian) calendar year, month, day, day of the week, hour, minute display



The operation panel is necessary for the use of calendar functions.

■ General specifications

Insulation resistance:	Between power and ground terminals: 20 M Ω or more at 500 V DC Between output and ground terminals: 20 M Ω or more at 500 V DC
Withstand voltage:	Between power and ground terminals: 1 minute at 1500 V AC Between output and ground terminals: 1 minute at 1000 V AC
Withstand noise:	1500 V (peak to peak) Pulse width: 1 μ s Rise time: 1 ns By noise simulator
Ambient temperature range:	0 to 50 °C
Ambient humidity range:	45 to 85 % RH (Non condensing)
Ambient operating atmosphere:	There should be neither corrosive gases nor much dust.
Storage temperature range:	-10 to +60 °C
Storage humidity range:	95 % RH or less (Non condensing)
Dimensions:	48 (W) \times 96 (H) \times 100 (D) mm
Weight:	Approx. 300 g

3. MOUNTING



WARNING

To prevent electric shock or instrument failure, always turn off the power before mounting or removing the instrument.

3.1 Mounting Environment

- (1) This instrument is intended to be used under the following environmental conditions. (IEC61010-1)
[OVERVOLTAGE CATEGORY II, POLLUTION DEGREE 2]
- (2) Use this instrument within the following environment conditions:
 - Allowable ambient temperature: 0 to 50 °C
 - Allowable ambient humidity: 45 to 85 % RH (Non condensing)
 - Installation environment conditions: Indoor use
Altitude up to 2000 m
- (3) Avoid the following conditions when selecting the mounting location:
 - Rapid changes in ambient temperature which may cause condensation.
 - Corrosive or inflammable gases.
 - Direct vibration or shock to the mainframe.
 - Water, oil, chemicals, vapor or steam splashes.
 - Excessive dust, salt or iron particles.
 - Excessive induction noise, static electricity, magnetic fields or noise.
 - Direct air flow from an air conditioner.
 - Exposure to direct sunlight.
 - Excessive heat accumulation.
- (4) Mount this instrument in the panel considering the following conditions:
 - Provide adequate ventilation space so that heat does not build up.
 - Do not mount this instrument directly above equipment that generates large amount of heat (heaters, transformers, semi-conductor functional devices, large-wattage resistors).
 - If the ambient temperature rises above 50 °C, cool this instrument with a forced air fan, cooler, etc. Cooled air should not blow directly on this instrument.
 - In order to improve safety and the immunity to withstand noise, mount this instrument as far away as possible from high voltage equipment, power lines, and rotating machinery.
 - High voltage equipment: Do not mount within the same panel.
 - Power lines: Separate at least 200 mm
 - Rotating machinery: Separate as far as possible
- (5) If this instrument is permanently connected to equipment, it is important to include a switch or circuit-breaker into the installation. This should be in close proximity to the equipment and within easy reach of the operator. It should be marked as the disconnecting device for the equipment.

3.2 Dimensions

■ External dimensions

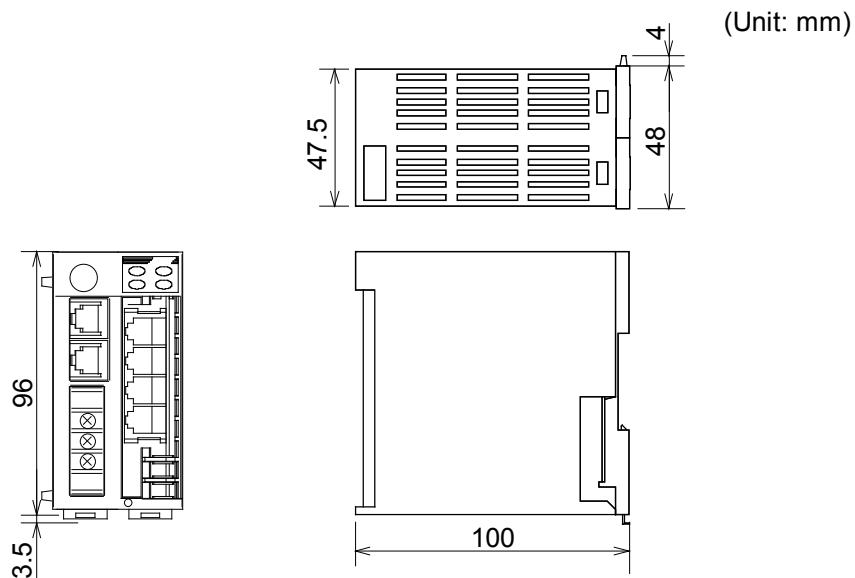

Fig.3-1 External dimensions

■ Module mounting depth (Mounting on the DIN rail)

The mounting depth of each module is 108 mm from the mounting surface inside the panel to the front of the module with the module mounted on the DIN rail. However, when modular connector cables are plugged in, additional depth is required.

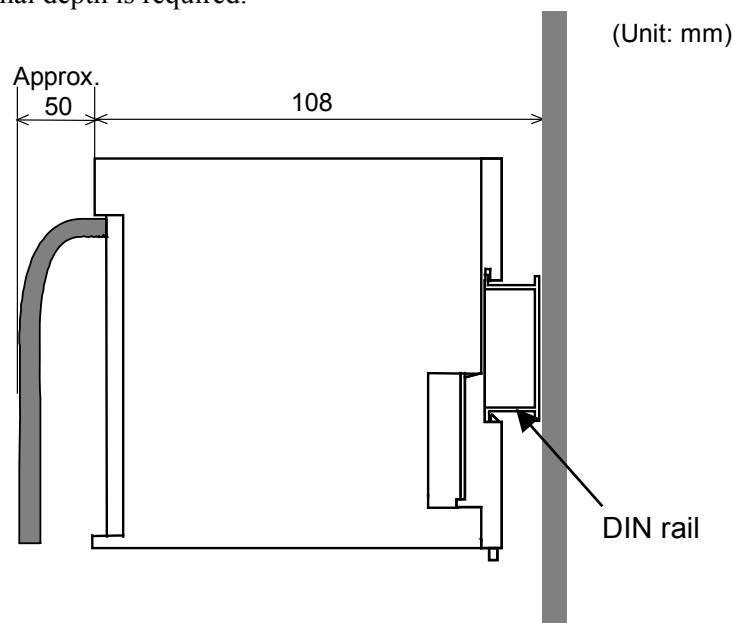

Fig.3-2 Mounting depth

3.3 Mounting the Mother Block

The mother block can be mounted to a panel or DIN rail.

■ Panel mounting

1. Refer to both the panel mounting dimensions below and the external dimensions in previous section when selecting the location.

(Unit: mm)

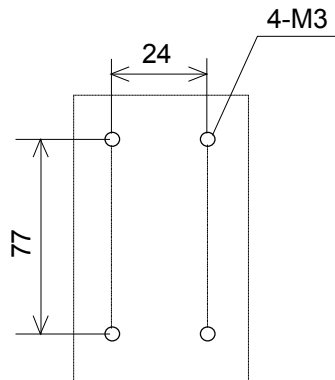
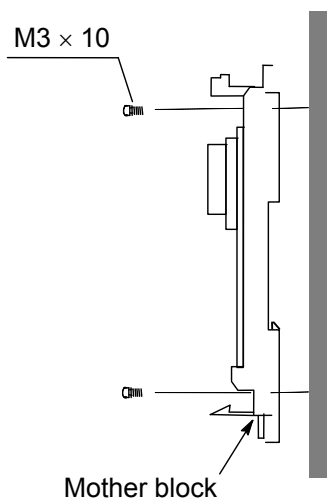

Fig.3-3 Mounting dimensions

2. Remove the module from the mother block. For details of removing the module, refer to **3.5 Removing the Module Mainframe (P. 14)**.
3. Connect the mother blocks together before tightening the screws on the panel.
(Customer must provide the set screws)



**Recommended tightening torque:
0.3 N·m (3 kgf·cm)**



When the mother block is mounted on the panel, 50 mm or more space is required at the top and bottom of the mother block to attach the module mainframe.

Fig.3-4 Mounting on the panel

■ DIN rail mounting

1. Remove the module mainframe from the mother block. For details of removing the module mainframe, refer to **3.5 Removing the Module Mainframe (P. 14)**.
2. Pull down both locking devices at the bottom of the mother block. (A)
3. Attach the top bracket of the mother block to the DIN rail and push the lower section into place on the DIN rail. (B)
4. Slide the locking devices up to secure the mother block to the DIN rail. (C)

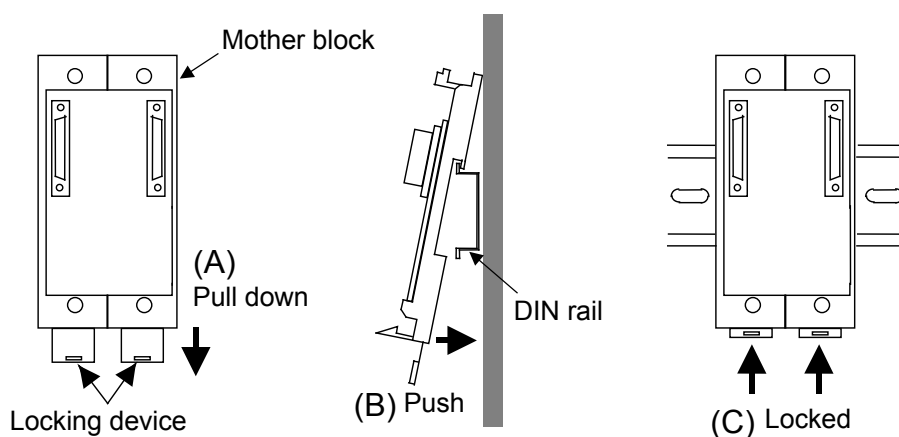

Fig.3-5 Mounting the mother block



When the mother block is mounted on panel, 50 mm or more space is required at the top and bottom of the mother block to attach the module mainframe.

3.4 Mounting the Module Mainframe

It engages the module with the mother block that is mounted on DIN rail or a panel.

1. Place the module mainframe opening on top of the mother block tab. (A)
2. Snap the lower part of module mainframe on to the mother block. (B)

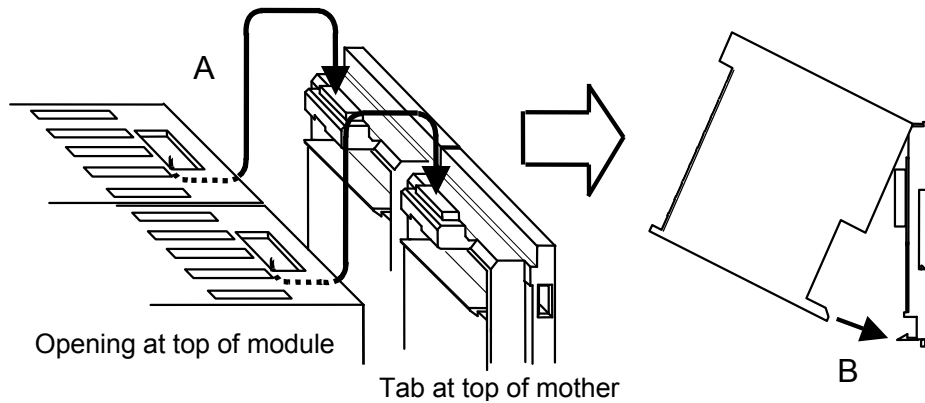

Fig.3-6 Mounting the module mainframe



A snapping sound will be heard when module mainframe is securely connected to mother block.

3.5 Removing the Module Mainframe

To separate the module mainframe from the mother block, press the bottom on the module, lifting upward, to release connection.

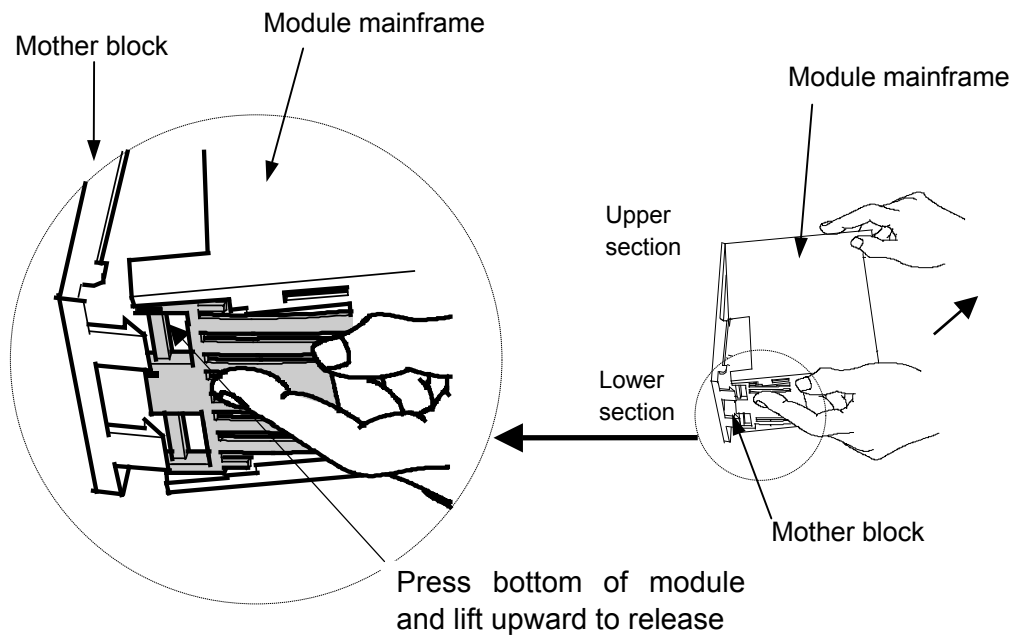

Fig.3-7 Removing the module mainframe

4. WIRING

4.1 Wiring Cautions



WARNING

To prevent electric shock or instrument failure, do not turn on the power until all wiring is completed. Make sure that the wiring is correct before applying power to the instrument.

- To avoid noise induction, keep communication signal wires away from instrument power line, load lines and power lines of other electric equipment.
- If there is electrical noise in the vicinity of the instrument that could affect operation, use a noise filter.
 - Shorten the distance between the twisted power supply wire pitches to achieve the most effective noise reduction.
 - Always install the noise filter on a grounded panel. Minimize the wiring distance between the noise filter output and the instrument power supply terminals to achieve the most effective noise reduction.
 - Do not connect fuses or switches to the noise filter output wiring as this will reduce the effectiveness of the noise filter.
- Power supply wiring must be twisted and have a low voltage drop.
- For an instrument with 24 V power supply, supply power from a SELV circuit.
- A suitable power supply should be considered in end-use equipment. The power supply must be in compliance with a limited-energy circuits (maximum available current of 8 A).
- Ground the instrument separately from other equipment. The grounding resistance should be 100 Ω or less. Use grounding wires with a cross section area of 2.0 mm² or more.
- Use the specified solderless terminals. Only these specified solderless terminals can be used due to the insulation between the terminals.

Screw Size: M3 × 7

Recommended tightening torque:
0.4 N·m (4 kgf·cm)

Applicable wire: Solid/Twisted wire of 0.25 to 1.65 mm²

Specified solderless terminals:

Manufactured by J.S.T MFG CO., LTD.

Circular terminal with isolation V1.25-MS3

(M3 screw, width 5.5 mm, hole diameter 3.2 mm)

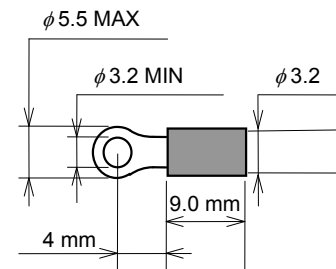

- Make sure that the any wiring such as solderless terminal is not in contact with the adjoining terminals.

4.2 Terminal Configuration

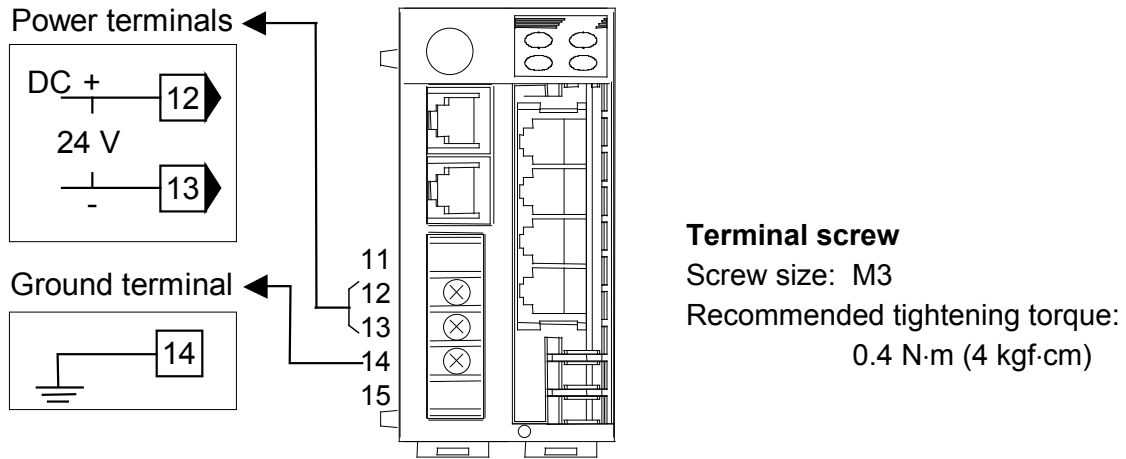

Fig.4-1 Power supply and ground wiring

- **Power supply**

21.6 to 26.4 V DC (Rating: 24V DC)

Ripple noise: less than 10 % (peak to peak)

- **Ground**

Ground the instrument separately from other equipment. The grounding resistance should be 100 Ω or less. Use grounding wires with a cross section area of 2.0 mm² or more.

4.3 Connection



WARNING

To prevent electric shock or instrument failure, turn off the power before connecting or disconnecting the instrument and peripheral equipment.

4.3.1 Connection to PLC

Customer is requested to prepare a communication cable fit for the **COM-E** to be connected by PLC.

■ YOKOGAWA FA-M3 series

● Pin layout of COM3

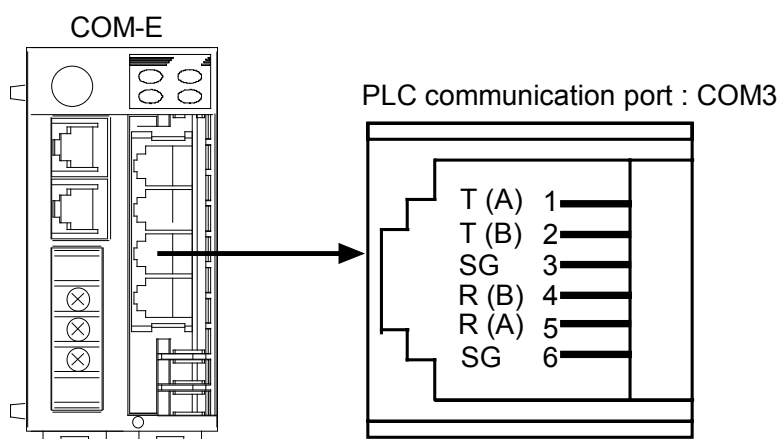

Fig.4-2 Pin layout of COM3



The 6-pin type modular connector should be used for the connection to the **COM-E**.
(Recommended manufacturer and model: Hirose Electric, TM4P-66P)



The details of the connectable connector for the PLC refer to the instruction manual for the used PLC.

● Pin number and signal name (RS-422A)

Pin No.	Signal Name	Symbol
1	Send Data	T (A)
2	Send Data	T (B)
3	Signal Ground	SG
4	Receive Data	R (B)
5	Receive Data	R (A)
6	Signal Ground	SG

● Diagram of RS-422A communication cable wiring

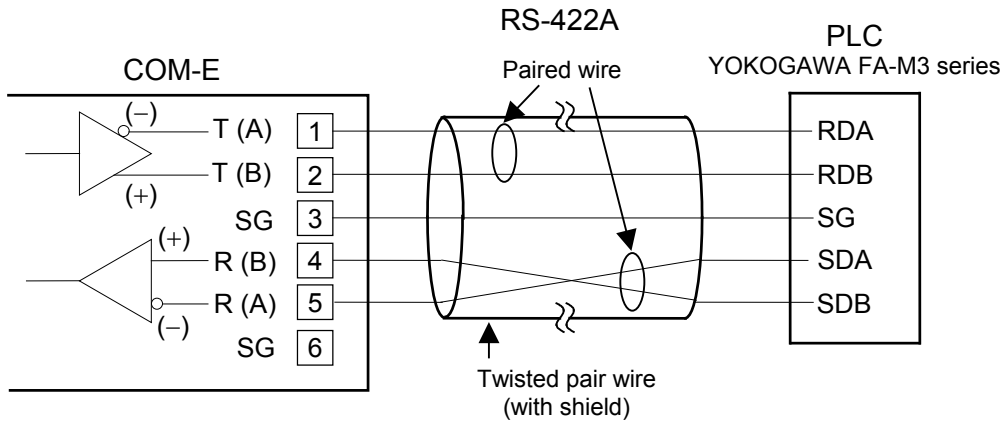

Fig.4-3 Communication cable wiring



Modular connector cable W-BF-01 * can use to connect PLC.

* Shields of the cable are connected to SG (No. 6 pin) of the COM-E connector.

A wiring example when using our W-BF-01 connection cable is shown in the following.

Cable type: W-BF-01-3000 (RKC product, Sold separately)

[Standard cable length: 3 m]

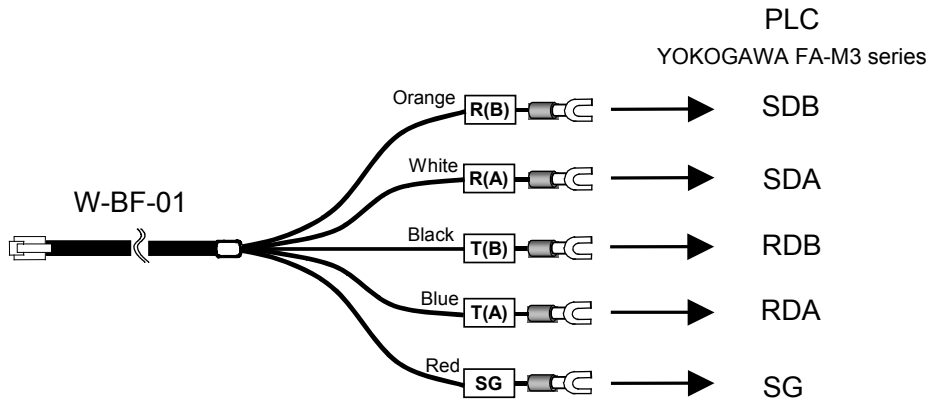

■ MITSUBISHI MELSEC A series (A, AnA, AnU types)/Q series/QnA series

● Pin layout of COM3

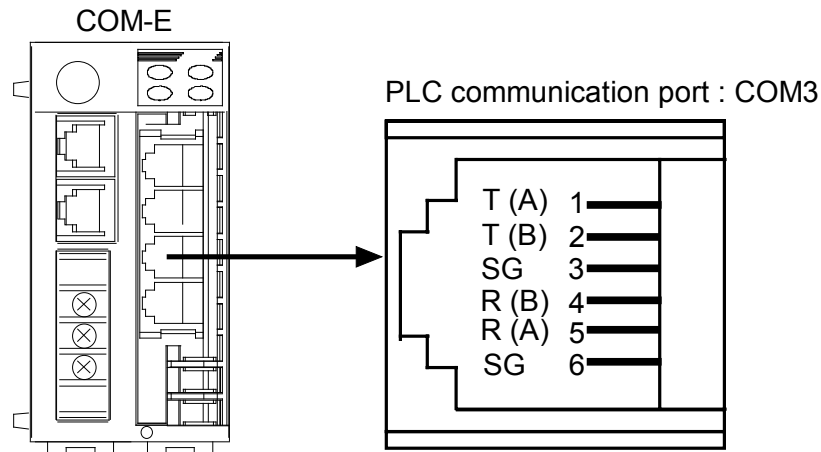

Fig.4-4 Pin layout of COM3



The 6-pin type modular connector should be used for the connection to the **COM-E**.
(Recommended manufacturer and model: Hirose Electric, TM4P-66P)



The details of the connectable connector for the PLC refer to the instruction manual for the used PLC.

● Pin number and signal name (RS-422A)

Pin No.	Signal Name	Symbol
1	Send Data	T (A)
2	Send Data	T (B)
3	Signal Ground	SG
4	Receive Data	R (B)
5	Receive Data	R (A)
6	Signal Ground	SG

● **Diagram of RS-422A communication cable wiring**

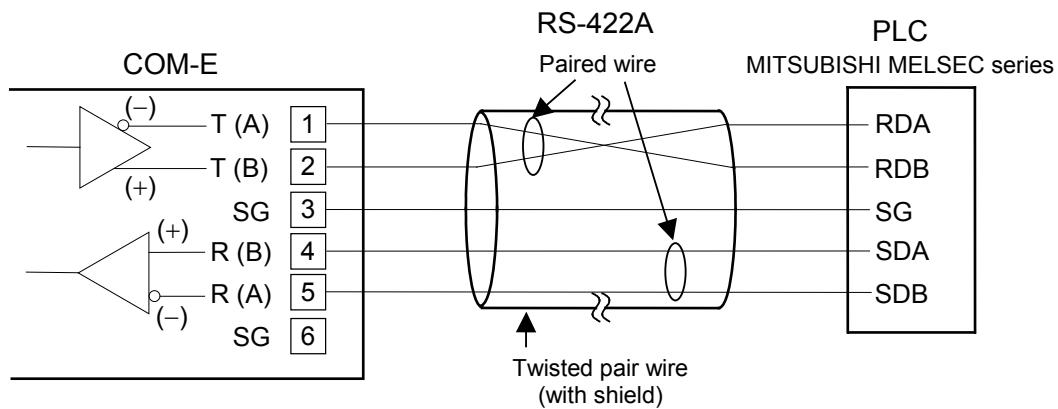

Fig.4-5 Communication cable wiring



For connection with the COM-E, use the Computer link unit.



Cannot connect to the PLCs CPU-port.



As communication protocol, the type 4 protocol control procedure only for MITSUBISHI is used.



When preparing a cable of connecting the Computer link unit belonging to the MITSUBISHI MELSEC A series of PLCs to our COM-E, cross each pair of wires as shown in Fig.4-14 as the A and B terminal positions on their terminal boards are not symmetrical.

Example: Connect the COM-E T (A) send data terminal to the RDB receive data terminal on the Computer link unit belonging to the MITSUBISHI MELSEC A series of PLCs.



Modular connector cable W-BF-01 * can use to connect PLC.

* Shields of the cable are connected to SG (No. 6 pin) of the COM-E connector.

A wiring example when using our W-BF-01 connection cable is shown in the following.

Cable type: W-BF-01-3000 (RKC product, Sold separately)

[Standard cable length: 3 m]

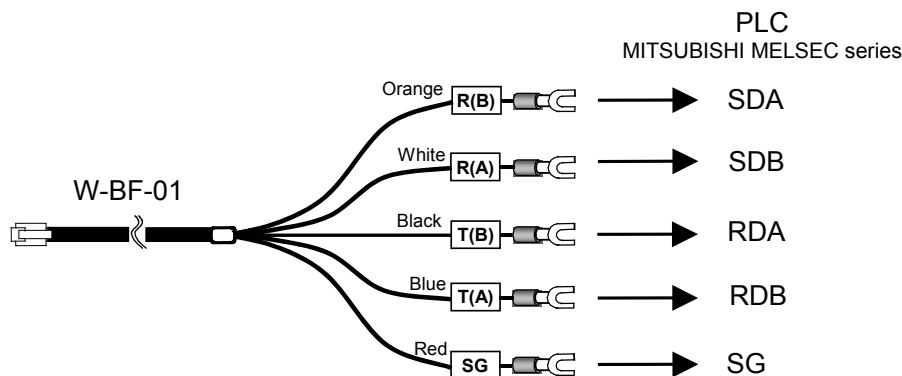

■ OMRON SYSMAC CS1 series

● Pin layout of COM3

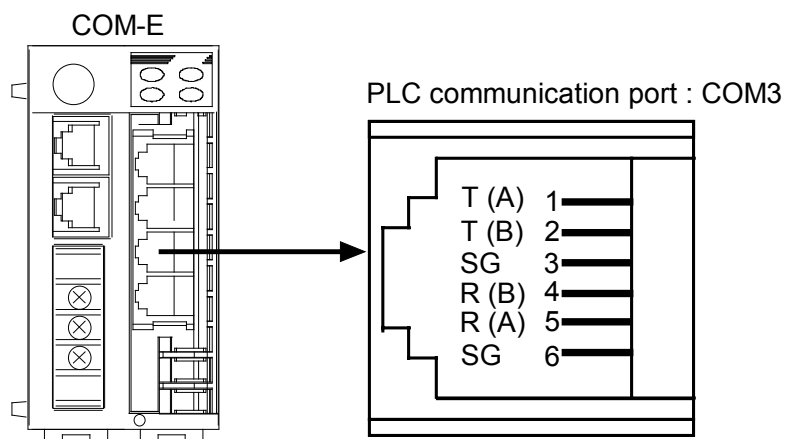

Fig.4-6 Pin layout of COM3



The 6-pin type modular connector should be used for the connection to the **COM-E**.
(Recommended manufacturer and model: Hirose Electric, TM4P-66P)



The details of the connectable connector for the PLC refer to the instruction manual for the used PLC.

● Pin number and signal name (RS-422A)

Pin No.	Signal Name	Symbol
1	Send Data	T (A)
2	Send Data	T (B)
3	Signal Ground	SG
4	Receive Data	R (B)
5	Receive Data	R (A)
6	Signal Ground	SG

● Diagram of RS-422A communication cable wiring

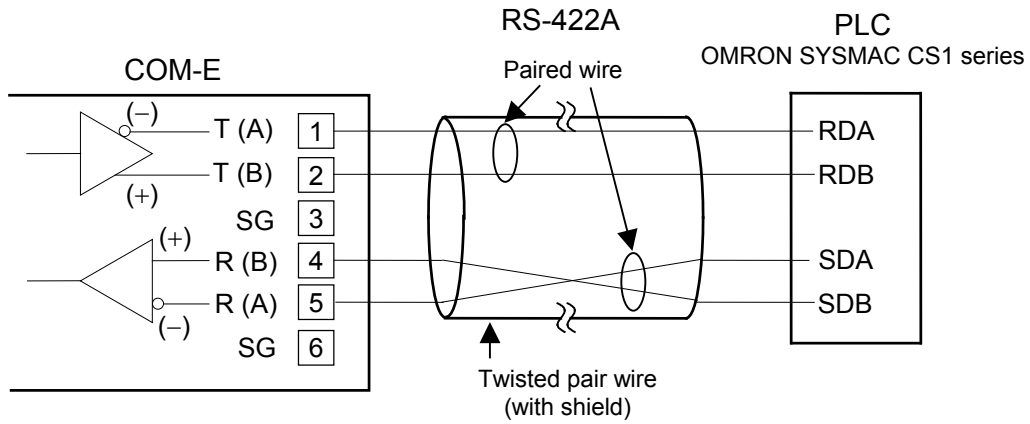

Fig.4-7 Communication cable wiring



Modular connector cable W-BF-01 * can use to connect PLC.

* Shields of the cable are connected to SG (No. 6 pin) of the COM-E connector.

A wiring example when using our W-BF-01 connection cable is shown in the following.

Cable type: W-BF-01-3000 (RKC product, Sold separately)

[Standard cable length: 3 m]

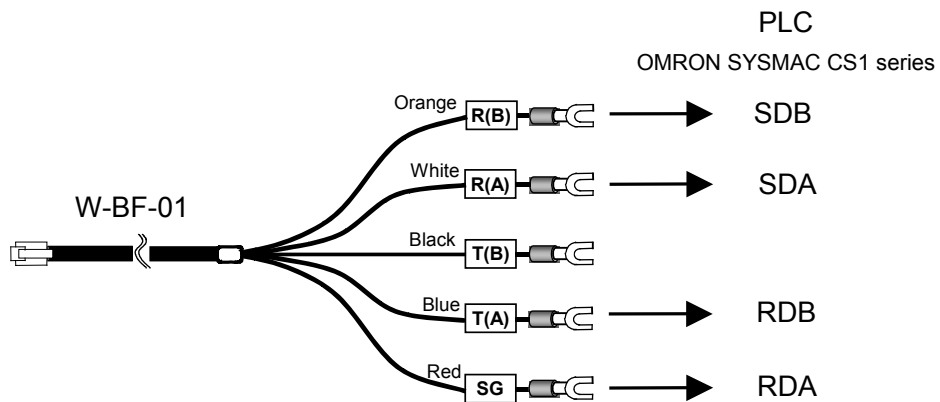

4.3.2 Connection to the LE100 and RKC temperature controller

For the connection cable, use the RKC product (Sold separately).

Cable type: W-BF-01: Connection cable for COM-E

W-BP-02: Connection cable for LE100

■ When using one LE100

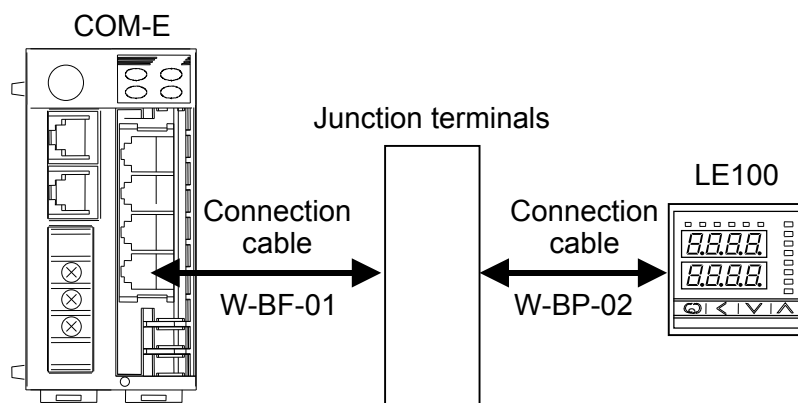

Cable type: W-BF-01-3000 (RKC product, Sold separately) [Standard cable length: 3 m]

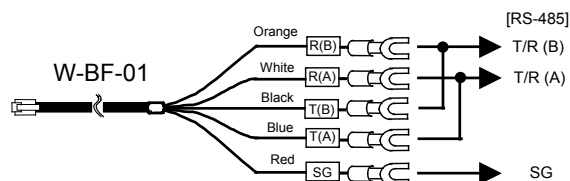

Cable type: W-BP-02-□ (RKC product, Sold separately) [□: Cable length]

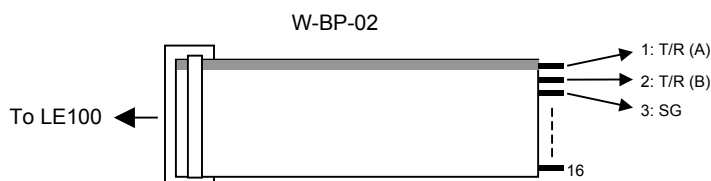

Fig.4-8 The connection cable is used



When using one LE100, always set addresses of them to 0.



When using the LE100, set communication interval time period for them to 25 ms or more.



In RS-485, connect the signal line T (A) and R (A). And, connect the signal line T (B) and R (B) in the same way.



For details on setting communication with the LE100, refer to the **LE100 Communication Instruction Manual (IMR01C02-E□)**.

■ When using two or more LE100s, or LE100s together with RKC temperature controllers

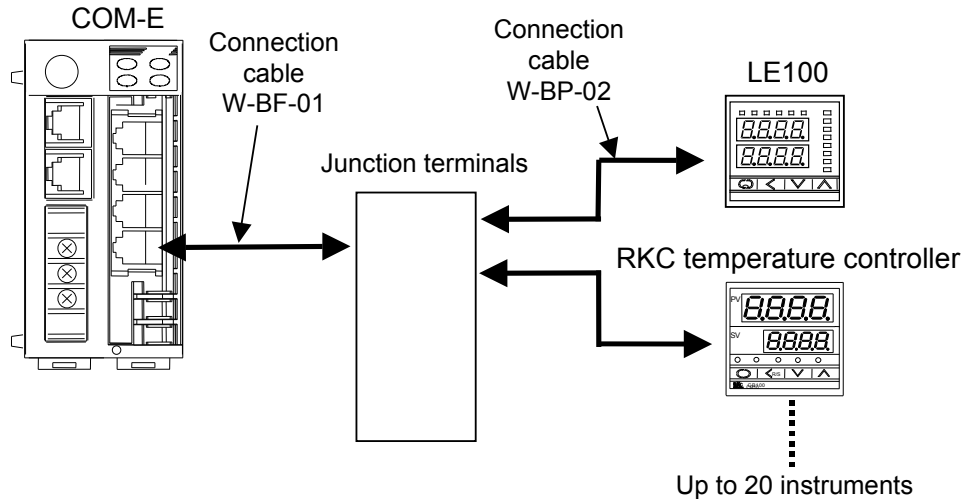

Cable type: W-BF-01-3000 (RKC product, Sold separately) [Standard cable length: 3 m]

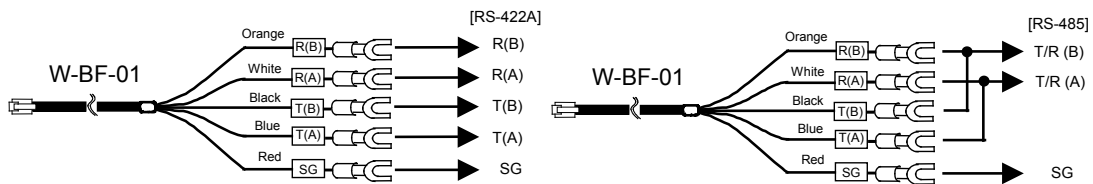

Cable type: W-BP-02-□ (RKC product, Sold separately) [□: Cable length]

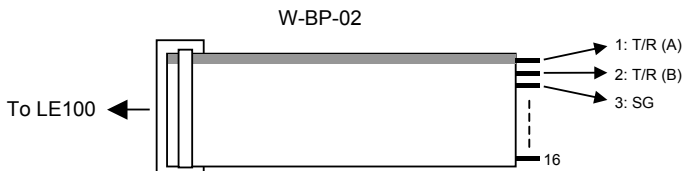







Fig.4-9 The connection cable is used

- 

When using the LE100 and RKC temperature controller, always use their addresses from address number 0 in succession. Any different address number can be assigned to the LE100 and RKC temperature controller.
- 

When using the LE100 or the RKC temperature controller, set communication interval time period for them to 25 ms or more.
- 

In RS-485, connect the signal line T (A) and R (A). And, connect the signal line T (B) and R (B) in the same way.
- 

Prepare cables for connecting the junction branch box to the temperature controllers on your side. (No cables included in the instrument)
- 

For details on setting communication with the **LE100** or the RKC temperature controller, refer to the **LE100 Communication Instruction Manual (IMR01C02-E□)** or the **communication instruction manual** for the RKC temperature controller.

■ Pin layout of COM4

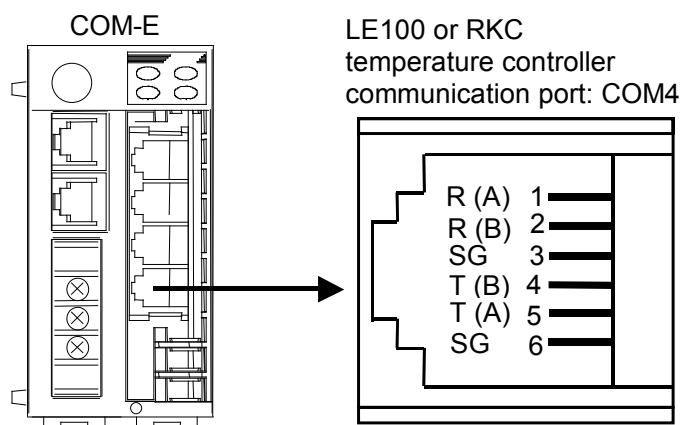

Fig.4-10 Pin layout of COM4



The 6-pin type modular connector should be used for the connection to the **COM-E**.
(Recommended manufacturer and model: Hirose Electric, TM4P-66P)

■ Pin number and signal name (RS-422A)

Pin No.	Signal Name	Symbol
1	Receive Data	R (A)
2	Receive Data	R (B)
3	Signal Ground	SG
4	Send Data	T (B)
5	Send Data	T (A)
6	Signal Ground	SG

■ Diagram of communication cable wiring

● RS-485

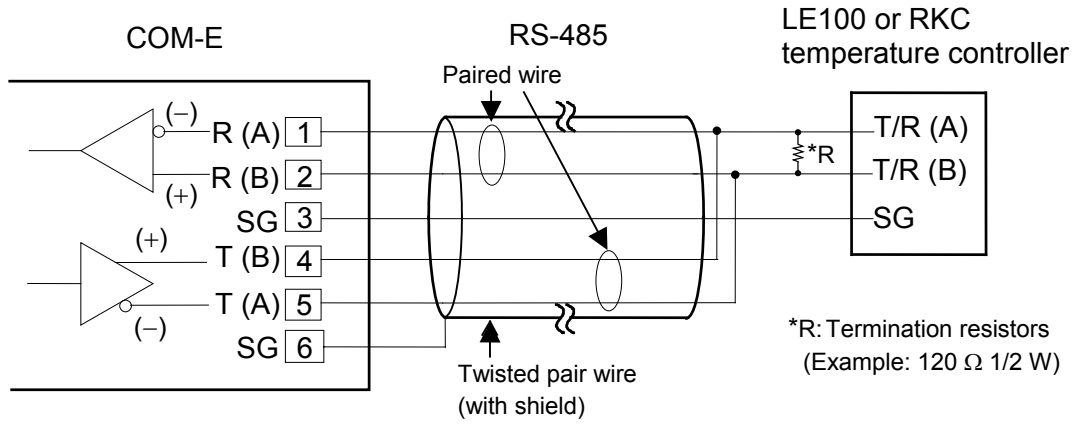

Fig.4-11 Communication cable wiring

📖 In RS-485, connect the signal line T (A) and R (A). And, connect the signal line T (B) and R (B) in the same way.

● RS-422A

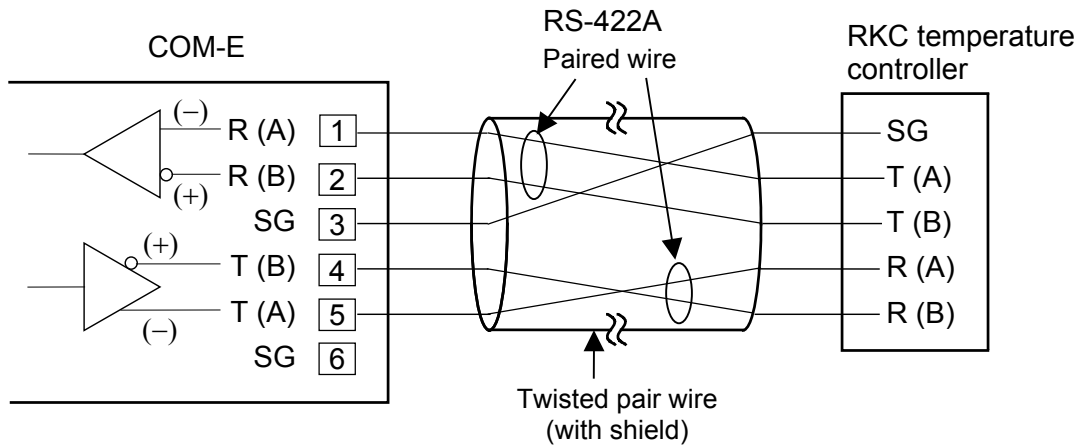

Fig.4-12 Communication cable wiring

📖 Modular connector cable W-BF-01 * can use to connect RKC temperature controller.
* Shields of the cable are connected to SG (No. 6 pin) of the COM-E connector.

4.3.3 Connection to the host computer

Customer is requested to prepare a communication cable fit for the **COM-E** to be connected by the host computer.

■ Pin layout of COM1

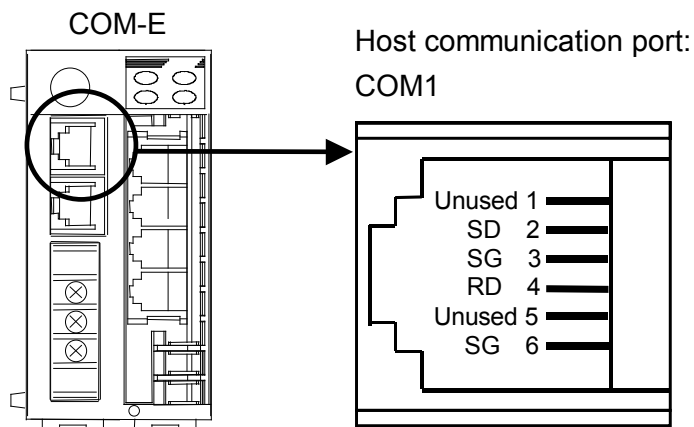

Fig.4-13 Pin layout of COM1

■ Pin number and signal name (RS-232C)

Pin No.	Signal Name	Symbol
1	—	Unused
2	Send Data	SD (TXD)
3	Signal Ground	SG
4	Receive Data	RD (RXD)
5	—	Unused
6	Signal Ground	SG

■ Diagram of RS-232C communication cable wiring

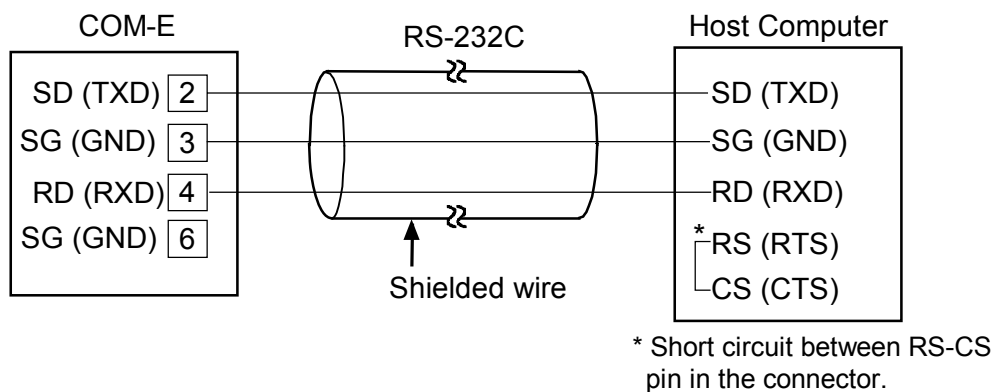
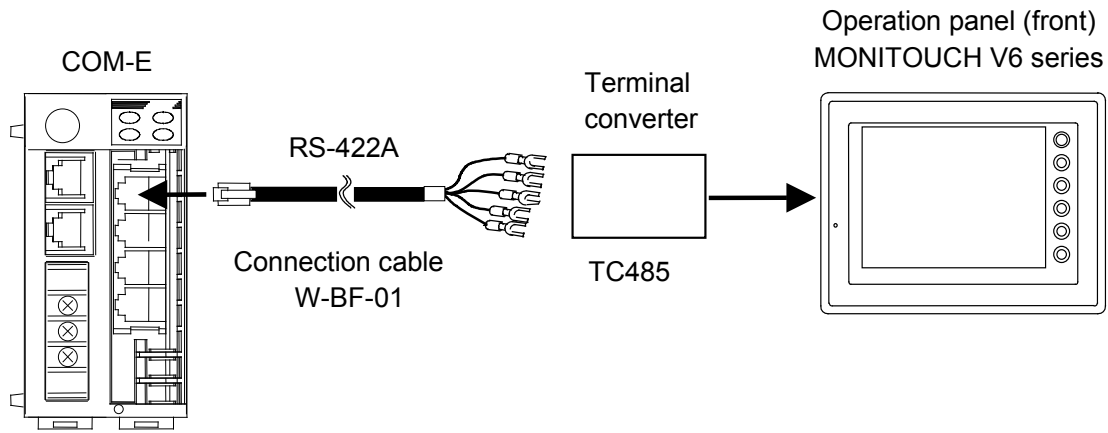

Fig.4-14 Communication cable wiring

4.3.4 Connection to operation panel

For the connection cable, use the RKC product (Sold separately).

Cable type: W-BF-01-3000 [Standard cable length: 3 m]



Cable type: W-BF-01-3000 (RKC product, Sold separately)

[Standard cable length: 3 m]

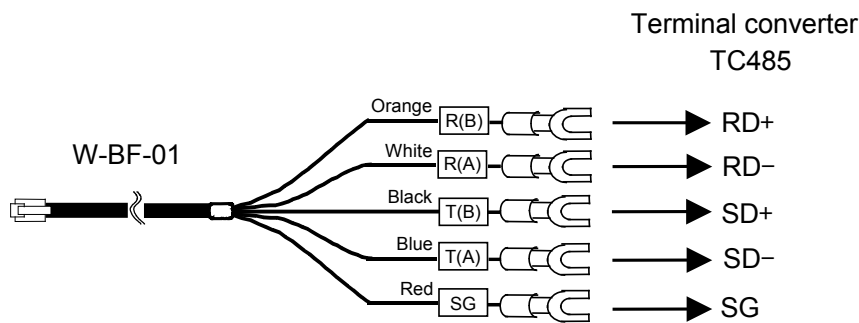

Fig.4-15 The connection cable is used



For connection of the operation panel with the connection cable, the TC485 terminal converter connector (sold separately: Hakko Electronics Co., Ltd) is required.



The details of the connectable connector for the operation panel refer to the instruction manual for the V6 series of Hakko Electronics Co., Ltd.

■ Pin layout of COM2

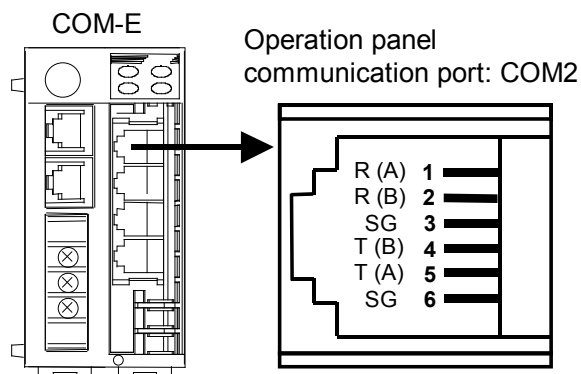



Fig.4-16 Pin layout of COM2

- 
 The 6-pin type modular connector should be used for the connection to the COM-E. (Recommended manufacturer and model: Hirose Electric, TM4P-66P)
- 
 The details of the connectable connector for the operation panel refer to the instruction manual for the V6 series of Hakko Electronics Co., Ltd.

■ Pin number and signal name (RS-422A)

Pin No.	Signal Name	Symbol
1	Receive Data	R (A)
2	Receive Data	R (B)
3	Signal Ground	SG
4	Send Data	T (B)
5	Send Data	T (A)
6	Signal Ground	SG

■ Diagram of RS-422A communication cable wiring

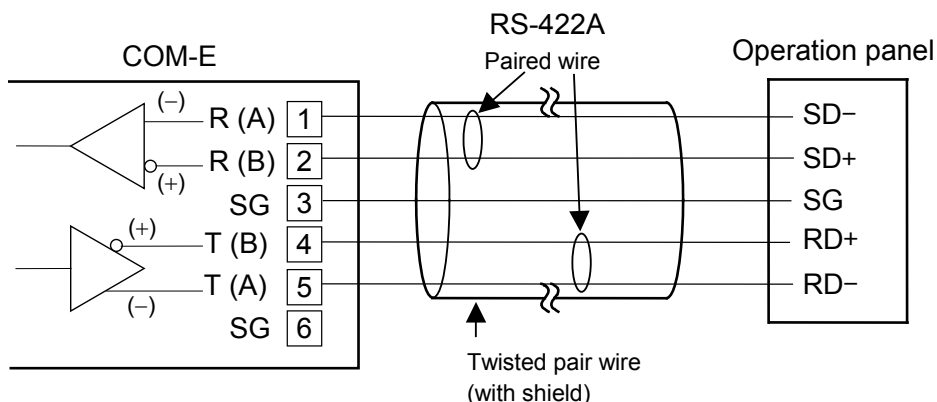



Fig.4-17 Communication cable wiring

- 
 Modular connector cable W-BF-01 * can use to connect the operation panel.
- * Shields of the cable are connected to SG (No. 6 pin) of the COM-E connector.

5. PLC COMMUNICATION

5.1 Rotary Switch Setting

The COM-E rotary switch can set the PLC register area.
For this setting, use a small blade screwdriver.

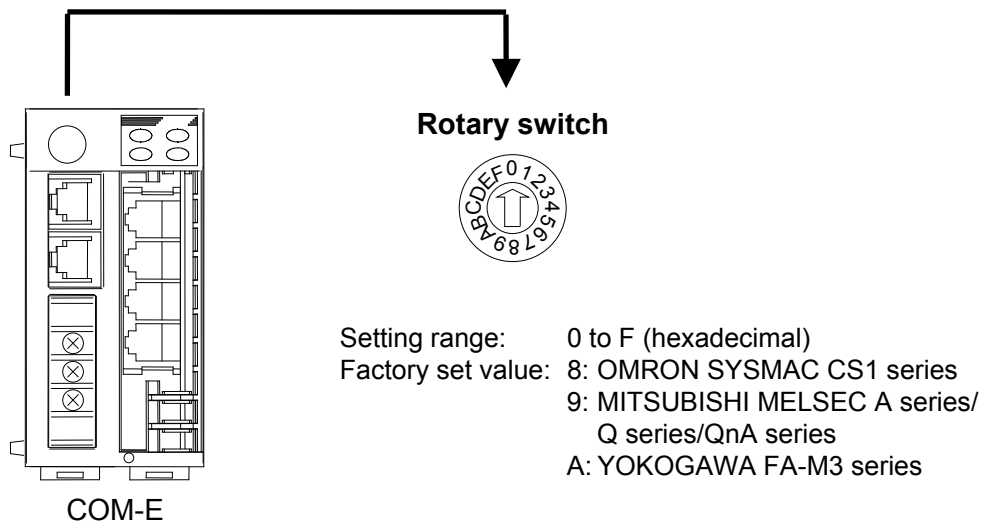

Fig.5-1 Rotary switch



It is prohibited to set the rotary switch to the “B” position.



Select the setting of rotary switch after confirming the PLC register area.

5.2 PLC Setting

5.2.1 YOKOGAWA FA-M3 series



Please turn on number 1 only and turn off numbers 2 to 8 of the data format configuration switch, which there is in personal computer link module F3LC11-2N belonging to the YOKOGAWA FA-M3 series of PLCs. When the data format configuration switch turn on number 1 only and turn off numbers 2 to 8, these come to the following data format.

- Data bit: 8
- Parity bit: Without
- Stop bit: 1
- Checksum: Without
- Final character specification: Without
- Protection function: Without



For details on setting with the PLC, refer to the instruction manual for the used PLC.

■ Rotary switch Number of COM-E and PLC register area

Rotary switch No.	PLC register area		Remarks
0	Area available in D register	D1000 to D1399	—
1	Area available in D register	D1500 to D1899	—
2	Area available in D register	D2000 to D2399	—
3	Area available in D register	D2500 to D2899	—
4	Area available in D register	D3000 to D3399	—
5	Area available in D register	D3500 to D3899	—
6	Area available in D register	D4000 to D4399	—
7	Area available in D register	D4500 to D4899	—
8	Area available in D register	D5000 to D5399	—
9	Area available in D register	D5500 to D5899	—
A	Area available in D register	D6000 to D6399	—
B	Do not set this one (default mode)		—
C	Area available in W register	W0000 to W0399	Not usable
D	Area available in W register	W0500 to D0899	—
E	Area available in D register	D0000 to D0399	Not usable
F	Area available in D register	D0500 to D0899	—

5.2.2 MITSUBISHI MELSEC A series (A, AnA, AnU types)/Q series/QnA series



Please set the Computer link unit belonging to the MITSUBISHI MELSEC series of PLCs as follows.

- Protocol: MITSUBISHI MELSEC series special protocol type 4
- Data bit: 8
- Parity bit: Without
- Stop bit: 1
- Sum check code: Provided
- Writing during RUN: ON
- Station number: 00
- PC number: FF



For details on setting with the PLC, refer to the instruction manual for the used PLC.

■ Rotary switch Number of COM-E and PLC register area

Rotary switch No.	PLC register area		Remarks
0	Area available in D register	D1000 to D1399	Corresponding to AnA/AnU type CPU, Q series and QnA series. Corresponding to the instrument model which uses the QR/QW command as a communication command.
1	Area available in D register	D1500 to D1899	
2	Area available in D register	D2000 to D2399	
3	Area available in D register	D2500 to D2899	
4	Area available in D register	D3000 to D3399	
5	Area available in D register	D3500 to D3899	
6	Area available in D register	D4000 to D4399	
7	Area available in D register	D4500 to D4899	
8	Area available in D register	D5000 to D5399	
9	Area available in D register	D5500 to D5899	
A	Area available in D register	D6000 to D6399	—
B	Do not set this one (default mode)		
C	Area available in W register	W0000 to W018F	Corresponding to A type CPU. *
D	Area available in W register	W0200 to D038F	Corresponding to the instrument model which uses the WR/WW command as a communication command.
E	Area available in D register	D0000 to D0399	
F	Area available in D register	D0500 to D0899	

* A type CPU model code: A1S, A1SJ, A0J2H, A1, A1N, A2 (S1), A2N (S1), A2S, A2A (S1), A2U, A2US, A2C, A52G, A3, A3N, A3A, A3U, A4U, A3H, A3M, A73 or A7LMS-F

5.2.3 OMRON SYSMAC CS1 series



Please set the CPU unit belonging to the OMRON SYSMAC CS1 series of PLCs as follows.

- Serial communication mode: high-order link method
- Data bit: 8
- Parity bit: Provided (even)
- Stop bit: 1
- Unit number (Model number) : 00



For details on setting with the PLC, refer to the instruction manual for the used PLC.

■ Rotary switch Number of COM-E and PLC register area

Rotary switch No.	PLC register area		Remarks
0	Area available in D register	D1000 to D1399	—
1	Area available in D register	D1500 to D1899	—
2	Area available in D register	D2000 to D2399	—
3	Area available in D register	D2500 to D2899	—
4	Area available in D register	D3000 to D3399	—
5	Area available in D register	D3500 to D3899	—
6	Area available in D register	D4000 to D4399	—
7	Area available in D register	D4500 to D4899	—
8	Area available in D register	D5000 to D5399	—
9	Area available in D register	D5500 to D5899	—
A	Area available in D register	D6000 to D6399	—
B	Do not set this one (default mode)		—
C	Area available in D register	D7000 to D7399	—
D	Area available in D register	D7500 to D7899	—
E	Area available in D register	D0000 to D0399	—
F	Area available in D register	D0500 to D0899	—

5.3 The LE100 and RKC Temperature Controller Setting

Please set the LE100 and RKC temperature controller side as follows.

■ LE100

Setting items	Description
Communication speed	19200 bps
Data bit	8
Stop bit	1
Parity bit	Without
Communication interval time	25 ms or more
Device address	0 to 19

■ CB100/CB400/CB500/CB700/CB900

Setting items	Description
Communication speed	19200 bps
Data bit	8
Stop bit	1
Parity bit	Without
Communication interval time	15 or more (25 ms or more)
Device address	0 to 19

■ REX-F400/REX-F700/REX-F900

Setting items	Description
Communication speed	19200 bps
Data bit	8
Stop bit	1
Parity bit	Without
Communication interval time	25 ms or more
Device address	0 to 19

■ SA200

Setting items	Description
Communication speed	19200 bps
Data bit	8
Stop bit	1
Parity bit	Without
Communication interval time	25 ms or more
Device address	0 to 19



Always use their addresses from address number 0 in succession.



For details on setting communication with the **LE100** or the RKC temperature controller, refer to the **LE100 Communication Instruction Manual (IMR01C02-E□)** or the **communication instruction manual** for the RKC temperature controller.

5.4 Communication Data

5.4.1 Request command and data transfer

Data transfer between the PLC and LE100, or the PLC and RKC temperature controller are executed by the request command (Register area No. 20).

■ Request command “0: Monitor”

Command which requests the LE100 to write data items such as measured values, etc. (attribute: RO) to the PLC side. The COM-E always repeats data writing until “1: Setting” or “2: Set value monitor” is set to the request command. The COM-E communication status is set to “1: Writing on monitor data” during data transfer.

Data transfer procedures

[Example]

- Set “0: Monitor” to the request command on the PLC side.
- If the request command is set, the COM-E writes our LE100 data items such as measured values, etc. (attribute: RO) into the PLC.
- The COM-E communication status is set to “1: Writing on monitor data” during data transfer.

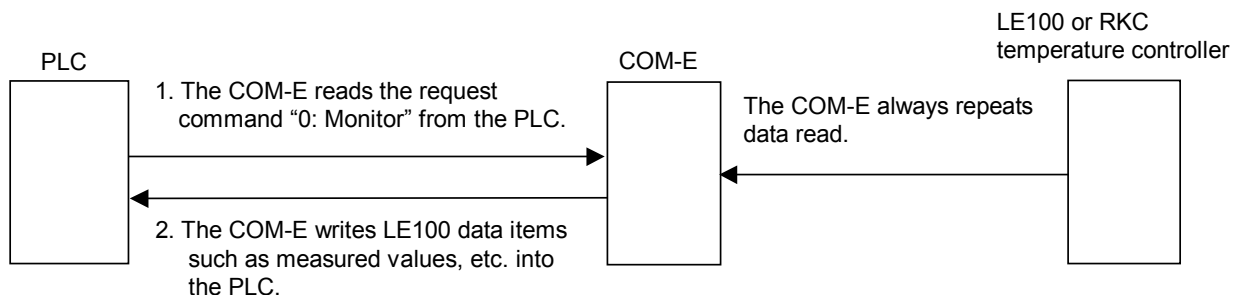

■ Request command “1: Setting”

This is the command of making a request to our LE100 for writing data items such as specific gravity, etc. (attribute: RW) set to the register on the PLC side (memory).

Data transfer procedures

[Example]

- Data items such as specific gravity, etc. (attribute: RW) are set to the register on the PLC side (memory).
- Set “1: Setting” to the request command on the PLC side.
- If the request command is set, the COM-E starts reading data items such as specific gravity, etc. (attribute: RW) on the PLC side. The COM-E communication status is set to “2: Reading out setting data” during data read on the PLC side.
- If the COM-E finishes reading data items from the PLC, it starts writing the data items read to our LE100. The COM-E communication status is set to “2: Reading out setting data” even during data write into our LE100.

Continued on the next page.

Continued from the previous page.

- After the data is transferred, the request command and COM-E communication status returns to “0: Monitor” and “1: Writing on monitor data,” respectively.

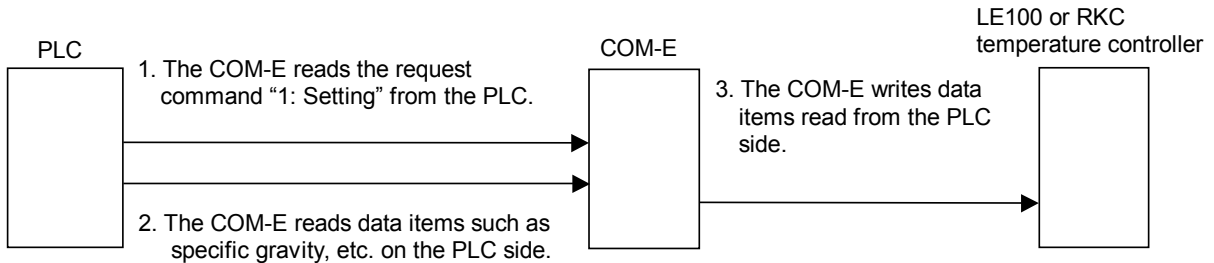

Before writing data to REX-F400/700/900 (RKC product), switch the operation mode to the Computer mode (COMP). Data can be monitored in the Local mode (LOC).

■ Request command “2: Set value monitor”

Command which requests the LE100 to write data items such as specific gravity, etc. (attribute: RW) to the PLC side.

Data transfer procedures

[Example]

- Set “2: Set value monitor” to the request command on the PLC side.
- If the request command is set, the COM-E writes our LE100 data items such as specific gravity, etc. (attribute: RW) into the PLC.
The COM-E communication status is set to “3: Writing on setting data” during data transfer.
- After the data is transferred, the request command and COM-E communication status returns to “0: Monitor” and “1: Writing on monitor data,” respectively.

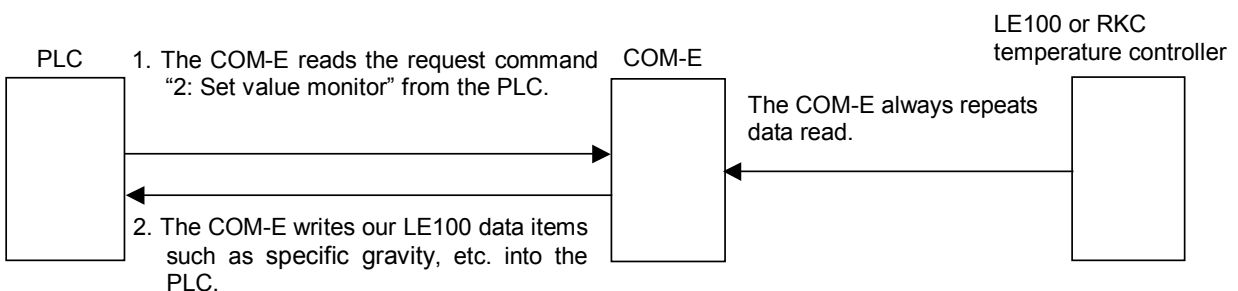

5.4.2 Communication status check

The communication status between the PLC and COM-E is confirmed by the COM-E communication status (Register area No. 21).

The COM-E always writes data on the COM-E communication status into the PLC.

COM-E communication status “0: Communication failure”:

“0: Communication failure” represents that communication between the COM-E and PLC is abnormal. If communication between the COM-E and PLC is normal, the COM-E communication status always becomes 1, 2, or 3.

COM-E communication status “1: Writing on monitor data”:

“1: Writing on monitor data” represents that data items such as measured values, etc. (attribute: RO) are being written into the PLC.

COM-E communication status “2: Reading out setting data”:

“2: Reading out setting data” represents that data items such as specific gravity, etc. (attribute: RW) are being read from the PLC.

COM-E communication status “3: Writing on setting data”:

“3: Writing on setting data” represents that data items such as specific gravity, etc. (attribute: RW) are being written into the PLC.

■ Communication status check procedures

[Example]

When the COM-E communication status is “1: Writing on monitor data”

1. “0: Communication failure” is set to the register on the PLC side (COM-E communication status).



Conduct this setting only when checking the communication status.

2. After setting, take appropriate wait time.



Wait time differs depending on the connectable number of our LE100 and temperature controllers. It is about 1 second/controller.

3. After a lapse of wait time, confirm that the value in the register on the PLC side (COM-E communication status) is “1: Writing on monitor data.”

5.4.3 Caution for handling communication data

(1) The alarm status in each channel is expressed for each bit.

- [Bit 0]: Adjusted data destruction error
- [Bit 1]: EEPROM write error
- [Bit 2]: EEPROM time out error
- [Bit 3]: Input capture hardware error
- [Bit 4]: Emptiness adjustment execution error
- [Bit 5]: Span setting by actual liquid error
- [Bit 6]: Span adjustment execution error
- [Bit 7]: Number of wafer processing times error
- [Bit 8]: Output setting by actual liquid error
- [Bit 9]: Linearization table creation error
- [Bit 10] *: Error flag (0: Normality 1: Abnormality of instrument or communication)
- [Bit 11] to [Bit 15]: Unused

* When using the RKC temperature controller together with the **COM-E** with this specification, only this bit is valid.

[Example] The following expressions are when EEPROM time out error is turned on.

- Binary digit: 00000000 00000100
- Hexadecimal numeral: 0004H
- Decimal numeral: 4

(2) The data type is treated as binary data with a sign and without a decimal point. For this reason, carefully express and set the data.

[Example] Specific gravity

Initial value of internal data: 1.0
Communication data: 10

(3) Any item whose attribute is RO (Read only) is always written the data to the PLC from the **COM-E**. During data write, “1: Writing on measured value” is written to “Communication status.”

(LE100 → **COM-E** → PLC)

(4) Any item whose attribute is R/W (Read and Write) is read the data only when “A request for reading out set value” is set to “1: Reading out set value.”

(PLC → **COM-E** → LE100)

(5) Any item whose attribute is R/W (Read and Write) is written the data only when “A request for reading out set value” is set to “2: Writing on set value.” After finish writing, “Communication status” is set to “1: Writing on measured value”, “A request for reading out set value” is set to “0: Monitoring.”

(LE100 → **COM-E** → PLC)

5.5 Communication Items List

5.5.1 Reference to communication items list

This communication items list summarizes the register area numbers of the PLC, communication items, data, setting ranges and attributes.

(1) ↓	(2) ↓	(3) ↓	(4) ↓	(5) ↓
Register area No.	Communication items	Data	Setting range	Attribute
1	Emptiness adjustment	20	0: Not executed 1: Executed	R/W
2	Digital filter	20	0 to 100 seconds (0: OFF)	R/W
3	Specific gravity ¹	20	0.800 to 2.500	R/W

- (1) Register area No.: It is written in register area numbers of the PLC that can be used with each communication item. Check the register number which will be actually used in **5.6 Table of register area numbers vs. register numbers. (P. 45)**.



Before operation, always set “The total number of LE100s and RKC temperature controllers” in register area number 22 to the desired number.

- (2) Communication items: It is written in each communication item
- (3) Data: It is written in data of each communication item.
 20: The maximum number of LE100s and RKC temperature controllers which can be connected to the **COM-E**.
 1: It is a common data of LE100s and RKC temperature controllers which be connected to the **COM-E**.
- (4) Setting range: It is written in setting ranges of each communication item.
- (5) Attribute: It is written in attributes of each communication item.
 ROs indicate monitor items which are read from the LE100 or the RKC temperature controller by the PLC .
 R/Ws indicate items which are read from and written to the LE100 or the RKC temperature controller by the PLC.



Never set any item whose attribute is RO (Read only).

5.5.2 LE100

(Attribute RO: Read only R/W: Read and Write)

Register area No.	Communication items	Data	Setting range	Attribute
1	Emptiness adjustment	20	0: Not executed 1: Executed	R/W
2	Digital filter	20	0 to 100 seconds (0: OFF)	R/W
3	Specific gravity ¹	20	0.800 to 2.500	R/W
4	Specific gravity setting transfer ²	20	0: Manual setting 1: Actual liquid setting	R/W
5	Error release	20	1: Executed	R/W
6	Scale 1 actual liquid setting ³	20	0 to 1250	R/W
7	Scale 2 actual liquid setting ³	20	1 to 1250	R/W
8	Hold reset	20	1: Executed	R/W
9	Output 1 set value ⁴	20	Scale low to Scale high	R/W
10	Output 2 set value ⁴	20	Scale low to Scale high	R/W
11	Output 3 set value ⁴	20	Scale low to Scale high	R/W
12	Output 4 set value ⁴	20	Scale low to Scale high	R/W
13	User unusable area	—	—	—
14	Measured value	20	Within input range ⁵	RO

Continued on the next page.

¹ This is the identifier effective when the specific gravity setting is changed to the manual setting.

² This is the identifier effective when the engineering unit is set to any unit other than % (% display of pressure), kPa or Pa.

³ This is the identifier effective when the specific gravity setting is changed to the actual liquid setting.

⁴ This is the identifier effective when output type of Process high, Process low, Deviation high, or Deviation low are selected.

⁵ Input Range Table

Unit setting	Unit	Range	Notes
0	mm	0 to 1250	The high limit is determined by the specific gravity setting.
1	%	0.0 to 100.0	% display of liquid level.
2	%	0.0 to 100.0	% display of pressure.
3	l	0 to 360	The decimal point position depends on the decimal point position selection.
4	m/	0 to 360	The decimal point position depends on the decimal point position selection.
5	kPa	0 to 9.807	—
6	Pa	0 to 9807	—

Continued from the previous page.

(Attribute RO: Read only R/W: Read and Write)

Register area No.	Communication items	Data	Setting range	Attribute
15	Alarm state ¹	20	The Error code status in each instrument is expressed for each bit.	RO
16	Specific gravity monitor	20	0.800 to 2.500	RO
17	Peak hold monitor	20	Scale low to Scale high	RO
18	Bottom hold monitor	20	Scale low to Scale high	RO
19	Amount of emptiness correction monitor	20	-5.00 to +5.00 of full span	RO
20	Request command	1	<p>0: Monitor Command which requests the LE100 to write data items such as Measured value (PV), etc. (attribute: RO) to the PLC side.</p> <p>1: Setting This is the command of making a request to LE100 for writing data items such as specific gravity, etc. (attribute: RW) set to the register on the PLC side (memory).</p> <p>2: Set value monitor Command which requests the LE100 to write data items such as specific gravity, etc. (attribute: RW) to the PLC side.</p>	R/W

Continued on the next page.

¹ Alarm state

Bit	Details	Bit	Details
0	Adjusted data destruction error	6	Span adjustment execution error
1	EEPROM write error	7	Number of wafer processing times error
2	EEPROM time out error	8	Output setting by actual liquid error
3	Input capture hardware error	9	Linearizing table creation error
4	Emptiness adjustment execution error	10	Error flag 0: Normality 1: Abnormality of instrument or communication
5	Span setting by actual liquid error	11 to 15	Unused



If two or more errors occur simultaneously, the total summation of these error codes is displayed.

Continued from the previous page.

(Attribute RO: Read only R/W: Read and Write)

Register area No.	Communication items	Data	Setting range	Attribute
21	COM-E communication status	1	0: Communication failure 1: Writing on monitor data During monitor data of attribute RO is written to PLC 2: Reading out setting data During setting data of attribute R/W is read from PLC 3: Writing on setting data During setting data of attribute R/W is written to PLC	RO
22	The total number of LE100s and RKC temperature controllers	1	1 to 20	R/W
23	User unusable area	—	—	—

5.5.3 RKC temperature controller

(REX-F400/700/900, CB100/400/500/700/900, SA200)

(Attribute RO: Read only R/W: Read and Write)

Register area No.	Communication items	Data	Setting range	Attribute
1 to 12	User unusable area	—	—	—
13	Set value (SV) ¹	20	Within input range of using the RKC's temperature controllers	R/W
14	Measured value (PV)	20	Within input range of using the RKC's temperature controllers	RO
15	Alarm state ²	20	The Error code status in each instrument is expressed for each bit. However, only the tenth bit is valid.	RO
16 to 19	User unusable area	—	—	—
20	Request command	1	0: Monitor Command which requests the RKC temperature controller to write data items such as Measured value (PV), etc. (attribute: RO) to the PLC side. 1: Setting This is the command of making a request to our temperature controller for writing data items such as Set value (SV), etc. (attribute: RW) set to the register on the PLC side (memory). 2: Set value monitor Command which requests the RKC temperature controller to write data items such as Set value (SV), etc. (attribute: RW) to the PLC side.	R/W

Continued on the next page.

¹ When using LE100s together with RKC temperature controllers in reference to this specification of COM-E, only RKC temperature controllers are available.

² Alarm state

Bit	Details	Bit	Details
0	Unused	6	Unused
1	Unused	7	Unused
2	Unused	8	Unused
3	Unused	9	Unused
4	Unused	10	Error flag 0: Normality 1: Abnormality of instrument or communication
5	Unused	11 to 15	Unused

Continued from the previous page.

(Attribute RO: Read only R/W: Read and Write)

Register area No.	Communication items	Data	Setting range	Attribute
21	COM-E communication status	1	0: Communication failure 1: Writing on monitor data During monitor data of attribute RO is written to PLC 2: Reading out setting data During setting data of attribute R/W is read from PLC 3: Writing on setting data During setting data of attribute R/W is written to PLC	RO
22	The total number of LE100s and RKC temperature controllers	1	1 to 20	R/W
23	User unusable area	—	—	—



Before writing data to REX-F400/700/900 (RKC product), switch the operation mode to the Computer mode (COMP). Data can be monitored in the Local mode (LOC).

5.6 Table of Register Area Numbers vs. Register Numbers

The register number used for the PLC differs depending on the rotary switch number of the COM-E. In the following table, any register number which will be actually used can be checked by referring to “Rotary switch No.” and “Register area No.” in **5.5 Communication Items List (P. 39)**.

■ For the Rotary switch No. 0 to 7

Register area No.	Rotary switch No.							
	0	1	2	3	4	5	6	7
1	D1000 to D1019	D1500 to D1519	D2000 to D2019	D2500 to D2519	D3000 to D3019	D3500 to D3519	D4000 to D4019	D4500 to D4519
2	D1020 to D1039	D1520 to D1539	D2020 to D2039	D2520 to D2539	D3020 to D3039	D3520 to D3539	D4020 to D4039	D4520 to D4539
3	D1040 to D1059	D1540 to D1559	D2040 to D2059	D2540 to D2559	D3040 to D3059	D3540 to D3559	D4040 to D4059	D4540 to D4559
4	D1060 to D1079	D1560 to D1579	D2060 to D2079	D2560 to D2579	D3060 to D3079	D3560 to D3579	D4060 to D4079	D4560 to D4579
5	D1080 to D1099	D1580 to D1599	D2080 to D2099	D2580 to D2599	D3080 to D3099	D3580 to D3599	D4080 to D4099	D4580 to D4599
6	D1100 to D1119	D1600 to D1619	D2100 to D2119	D2600 to D2619	D3100 to D3119	D3600 to D3619	D4100 to D4119	D4600 to D4619
7	D1120 to D1139	D1620 to D1639	D2120 to D2139	D2620 to D2639	D3120 to D3139	D3620 to D3639	D4120 to D4139	D4620 to D4639
8	D1140 to D1159	D1640 to D1659	D2140 to D2159	D2640 to D2659	D3140 to D3159	D3640 to D3659	D4140 to D4159	D4640 to D4659
9	D1160 to D1179	D1660 to D1679	D2160 to D2179	D2660 to D2679	D3160 to D3179	D3660 to D3679	D4160 to D4179	D4660 to D4679
10	D1180 to D1199	D1680 to D1699	D2180 to D2199	D2680 to D2699	D3180 to D3199	D3680 to D3699	D4180 to D4199	D4680 to D4699
11	D1200 to D1219	D1700 to D1719	D2200 to D2219	D2700 to D2719	D3200 to D3219	D3700 to D3719	D4200 to D4219	D4700 to D4719

Continued on the next page.

Continued from the previous page.

Register area No.	Rotary switch No.							
	0	1	2	3	4	5	6	7
12	D1220 to D1239	D1720 to D1739	D2220 to D2239	D2720 to D2739	D3220 to D3239	D3720 to D3739	D4220 to D4239	D4720 to D4739
13	D1240 to D1259	D1740 to D1759	D2240 to D2259	D2740 to D2759	D3240 to D3259	D3740 to D3759	D4240 to D4259	D4740 to D4759
14	D1260 to D1279	D1760 to D1779	D2260 to D2279	D2760 to D2779	D3260 to D3279	D3760 to D3779	D4260 to D4279	D4760 to D4779
15	D1280 to D1299	D1780 to D1799	D2280 to D2299	D2780 to D2799	D3280 to D3299	D3780 to D3799	D4280 to D4299	D4780 to D4799
16	D1300 to D1319	D1800 to D1819	D2300 to D2319	D2800 to D2819	D3300 to D3319	D3800 to D3819	D4300 to D4319	D4800 to D4819
17	D1320 to D1339	D1820 to D1839	D2320 to D2339	D2820 to D2839	D3320 to D3339	D3820 to D3839	D4320 to D4339	D4820 to D4839
18	D1340 to D1359	D1840 to D1859	D2340 to D2359	D2840 to D2859	D3340 to D3359	D3840 to D3859	D4340 to D4359	D4840 to D4859
19	D1360 to D1379	D1860 to D1879	D2360 to D2379	D2860 to D2879	D3360 to D3379	D3860 to D3879	D4360 to D4379	D4860 to D4879
20	D1380	D1880	D2380	D2880	D3380	D3880	D4380	D4880
21	D1381	D1881	D2381	D2881	D3381	D3881	D4381	D4881
22	D1382	D1882	D2382	D2882	D3382	D3882	D4382	D4882
23	D1383 to D1399	D1883 to D1899	D2383 to D2399	D2883 to D2899	D3383 to D3399	D3883 to D3899	D4383 to D4399	D4883 to D4899

- For the Rotary switch No. 8 to F
(However, the position of the rotary switch: B interdict from setting)

Register area No.	Rotary switch No.							
	8	9	A	B	C *	D *	E	F
1	D5000 to D5019	D5500 to D5519	D6000 to D6019	—	W0000 to W0013	W0200 to W0213	D0000 to D0019	D0500 to D0519
2	D5020 to D5039	D5520 to D5539	D6020 to D6039	—	W0014 to W0027	W0214 to W0227	D0020 to D0039	D0520 to D0539
3	D5040 to D5059	D5540 to D5559	D6040 to D6059	—	W0028 to W003B	W0228 to W023B	D0040 to D0059	D0540 to D0559
4	D5060 to D5079	D5560 to D5579	D6060 to D6079	—	W003C to W004F	W023C to W024F	D0060 to D0079	D0560 to D0579
5	D5080 to D5099	D5580 to D5599	D6080 to D6099	—	W0050 to W0063	W0250 to W0263	D0080 to D0099	D0580 to D0599
6	D5100 to D5119	D5600 to D5619	D6100 to D6119	—	W0064 to W0077	W0264 to W0277	D0100 to D0119	D0600 to D0619
7	D5120 to D5139	D5620 to D5639	D6120 to D6139	—	W0078 to W008B	W0278 to W028B	D0120 to D0139	D0620 to D0639
8	D5140 to D5159	D5640 to D5659	D6140 to D6159	—	W008C to W009F	W028C to W029F	D0140 to D0159	D0640 to D0659
9	D5160 to D5179	D5660 to D5679	D6160 to D6179	—	W00A0 to W00B3	W02A0 to W02B3	D0160 to D0179	D0660 to D0679
10	D5180 to D5199	D5680 to D5699	D6180 to D6199	—	W00B4 to W00C7	W02B4 to W02C7	D0180 to D0199	D0680 to D0699
11	D5200 to D5219	D5700 to D5719	D6200 to D6219	—	W00C8 to W00DB	W02C8 to W02DB	D0200 to D0219	D0700 to D0719

* Register numbers corresponding to rotary switch numbers C and D are expressed in hexadecimal notation. (Example of the MITSUBISHI MELSEC A series of PLCs)

Continued on the next page.

Continued from the previous page.

Register area No.	Rotary switch No.							
	8	9	A	B	C *	D *	E	F
12	D5220 to D5239	D5720 to D5739	D6220 to D6239	—	W00DC to W00EF	W02DC to W02EF	D0220 to D0239	D0720 to D0739
13	D5240 to D5259	D5740 to D5759	D6240 to D6259	—	W00F0 to W0103	W02F0 to W0303	D0240 to D0259	D0740 to D0759
14	D5260 to D5279	D5760 to D5779	D6260 to D6279	—	W0104 to W0117	W0304 to W0317	D0260 to D0279	D0760 to D0779
15	D5280 to D5299	D5780 to D5799	D6280 to D6299	—	W0118 to W012B	W0318 to W032B	D0280 to D0299	D0780 to D0799
16	D5300 to D5319	D5800 to D5819	D6300 to D6319	—	W012C to W013F	W032C to W033F	D0300 to D0319	D0800 to D0819
17	D5320 to D5339	D5820 to D5839	D6320 to D6339	—	W0140 to W0153	W0340 to W0353	D0320 to D0339	D0820 to D0839
18	D5340 to D5359	D5840 to D5859	D6340 to D6359	—	W0154 to W0167	W0354 to W0367	D0340 to D0359	D0840 to D0859
19	D5360 to D5379	D5860 to D5879	D6360 to D6379	—	W0168 to W017B	W0368 to W037B	D0360 to D0379	D0860 to D0879
20	D5380	D5880	D6380	—	W017C	W037C	D0380	D0880
21	D5381	D5881	D6381	—	W017D	W037D	D0381	D0881
22	D5382	D5882	D6382	—	W017E	W037E	D0382	D0882
23	D5383 to D5399	D5883 to D5899	D6383 to D6399	—	W017F to W018F	W037F to W038F	D0383 to D0399	D0883 to D0899

* Register numbers corresponding to rotary switch numbers C and D are expressed in hexadecimal notation. (Example of the MITSUBISHI MELSEC A series of PLCs)

6. HOST COMMUNICATION

6.1 Protocol

RKC communication uses the polling/selecting method to establish a data link. The basic procedure is followed ANSI X3.28 subcategories 2.5 and B1 basic mode data transmission control procedure (Fast selecting is the selecting method used in COM-E).

- The polling/selecting procedures are a centralized control method where the host computer controls the entire process. The host computer initiates all communication so the LE100 responds according to queries and commands from the host.
- The code use in communication is 7-bit ASCII code including transmission control characters.

Transmission control characters used in COM-E:

EOT (04H), ENQ (05H), ACK (06H), NAK (15H), STX (02H), ETB (17H), ETX (03H)

(): Hexadecimal

6.1.1 Communication data structure

■ **Data description (Transmission/receive data structure)**



Part of the data above is shown below.

● **Data length 6 digits**

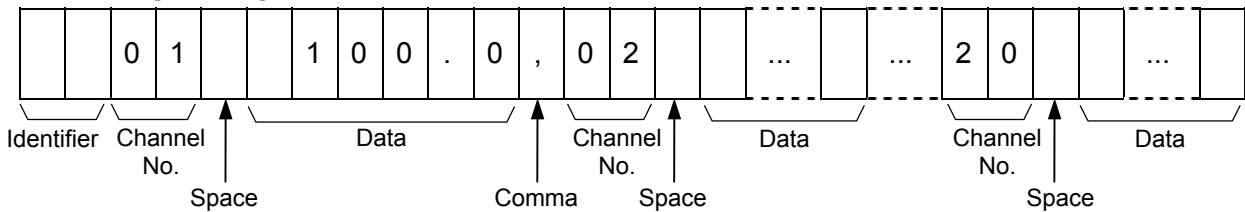

● **Data length 1 digit**

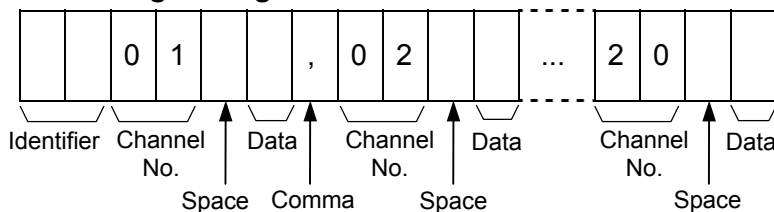

Each channel number becomes the number to identify the relevant LE100 which is multidrop-connected. The value obtained by adding “1” to the device address of the LE100 becomes the channel number.

6.1.2 Polling

Poling is the action where the host computer requests the connected LE100 by way of COM-E to transmit data.

An example of the polling procedure is shown below:

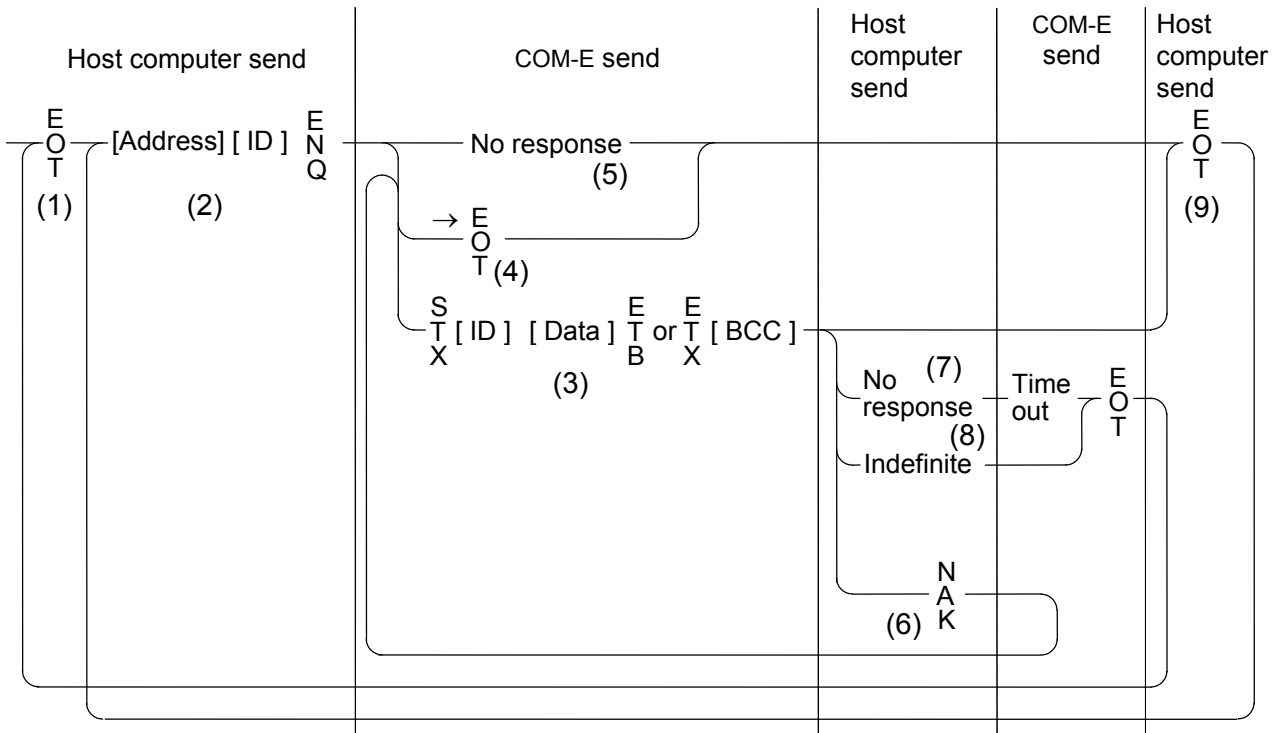

ID: Identifier

■ Polling procedures

(1) Data link initialization

Host computer sends EOT to the controllers to initiate data link before polling sequence.

(2) Data sent from host computer - Polling sequence

Host computer sends polling sequence with the format shown below:

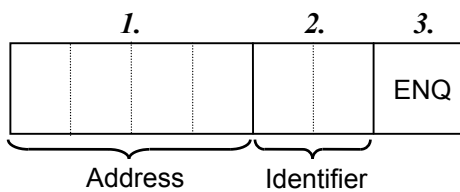

Example:

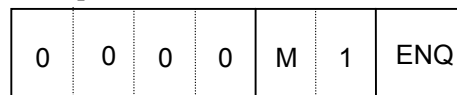

1. Polling address (4 digits)



In the COM-E, the polling address must be set to "0000".

2. Identifier (2 digits)

The identifier specifies the type of data that is requested from the LE100.

Always attach the ENQ code to the end of the identifier.

 Refer to **6.2 Communication Identifier List (P. 58)**.

3. ENQ

The ENQ is the transmission control character that indicates the end of the polling sequence.

The host computer then must wait for a response from the COM-E.

(3) Data sent from the COM-E

If the polling sequence is received correctly, the COM-E sends data in the following format:

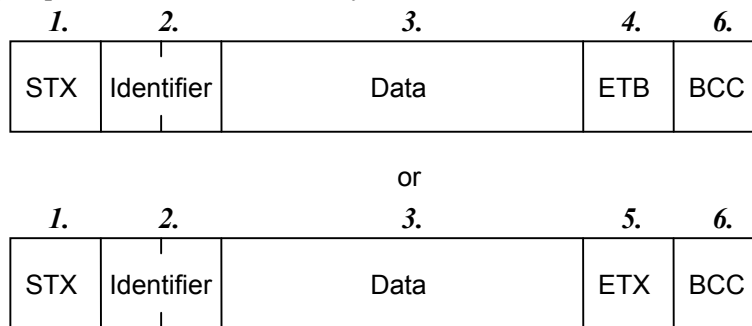

If the length of send data (from STX to BCC) exceeds 128 bytes, it is divided into blocks by ETB. In this case, the succeeding divided data is sent after STX.

1. STX

STX is the transmission control character which indicates the start of the text transmission (identifier and data).

2. Identifier (2 digits)

The identifier indicates the type of data (measured value, status and set value) sent to the host computer.

 Refer to **6.2 Communication Identifier List (P. 58)**.

3. Data

Data which is indicated by an identifier of this instrument, consisting of channel numbers, data, etc. Each channel number and data are delimited by a space (20H). The data and the next channel number are delimited by a comma.

- Channel number: 2-digit ASCII code, not zero-suppressed.

In this specification, the value obtained by adding “1” to the device address of the LE100 becomes the channel number.

- Data: ASCII code, zero-suppressed with spaces (20H). The number of digits varies depending on the type of identifier.

4. ETB

Transmission control character indicating the end of the block.

5. ETX

Transmission control character indicating the end of the text.

6. BCC

BCC (Block Check Character) detects error using horizontal parity and is calculated by horizontal parity (even number).

Calculation method of BCC: *Exclusive OR* all data and characters from STX through ETB or ETX, not including STX.

Example:

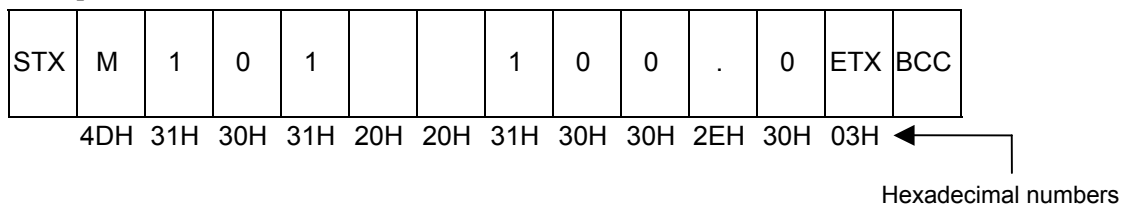

$$\text{BCC} = 4\text{DH} \oplus 31\text{H} \oplus 30\text{H} \oplus 31\text{H} \oplus 20\text{H} \oplus 20\text{H} \oplus 31\text{H} \oplus 30\text{H} \oplus 30\text{H} \oplus 2\text{EH} \oplus 30\text{H} \oplus 03\text{H} = 51\text{H}$$

(\oplus : *Exclusive OR*)

Value of BCC becomes 51H

(4) EOT send (Ending data transmission from the COM-E)

In the following cases, the COM-E sends EOT to terminate the data link:

- When the specified identifier is invalid
- When there is an error in the data format
- When all the data has been sent

(5) No response from the COM-E

The COM-E will not respond if the polling address is not received correctly. It may be necessary for the host computer to take corrective action such as a time-out.

(6) NAK (Negative acknowledge)

If the host computer does not receive correct data from the COM-E, it sends a negative acknowledgment NAK to the COM-E. The COM-E will re-send the same data when NAK is received. This cycle will go on continuously until either recovery is achieved or the data link is corrected at the host computer.

(7) No response from host computer

When the host computer does not respond within approximately three seconds after the COM-E sends data, the COM-E sends EOT to terminate the data link (time-out time: about 3 seconds).

(8) Indefinite response from host computer

The COM-E sends EOT to terminate the data link when the host computer response is indefinite.

(9) EOT (Data link termination)

The host computer sends EOT message when it is necessary to suspend communication with the COM-E or to terminate the data link due lack of response from the COM-E.

■ Polling procedure example (When the host computer requests data)

● Normal transmission

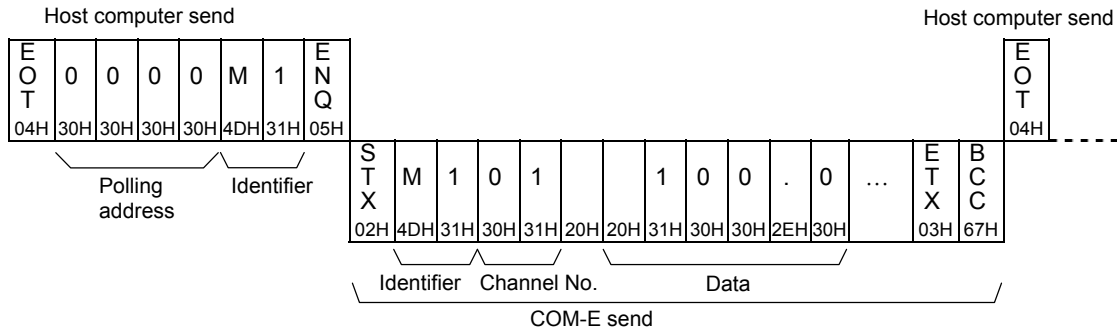

● Error transmission

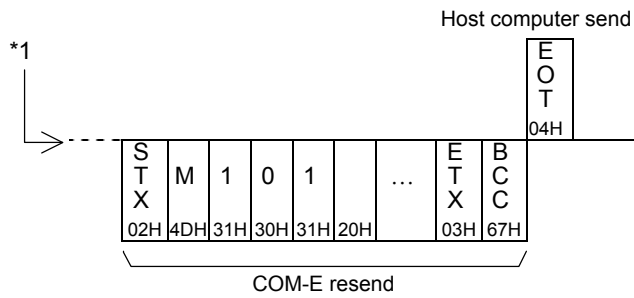
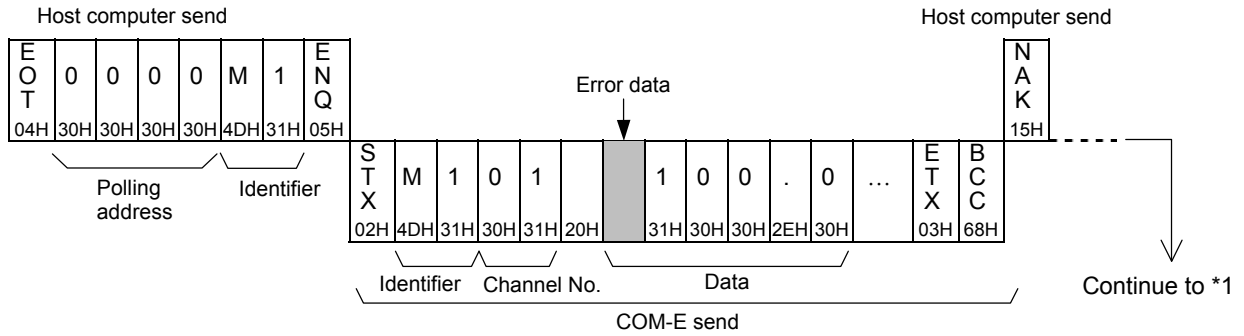

6.1.3 Selecting

Selecting is the action where the host computer requests one of the connected COM-E to receive data. An example of the selecting procedure is shown below:

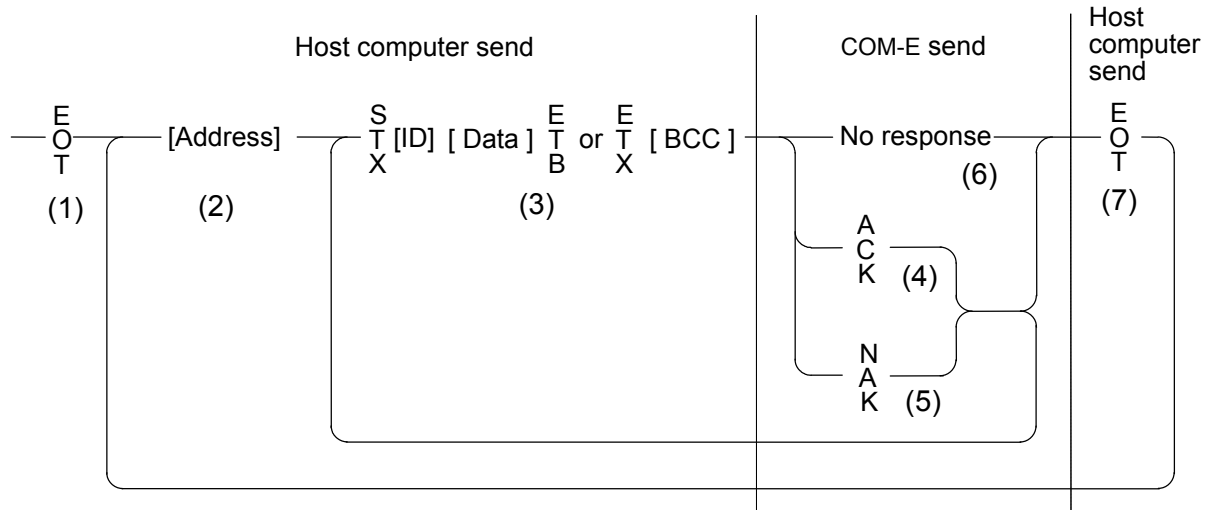

ID: Identifier

■ Selecting procedures

(1) Data link initialization

Host computer sends EOT to the COM-E to initiate data link before selecting sequence.

(2) Sending selecting address from the host computer

Host computer sends selecting address for the selecting sequence.

Selecting address (4 digits)



The selecting address becomes “0000” stationary with COM-E.

(3) Data sent from the host computer

The host computer sends data for the selecting sequence with the following format:

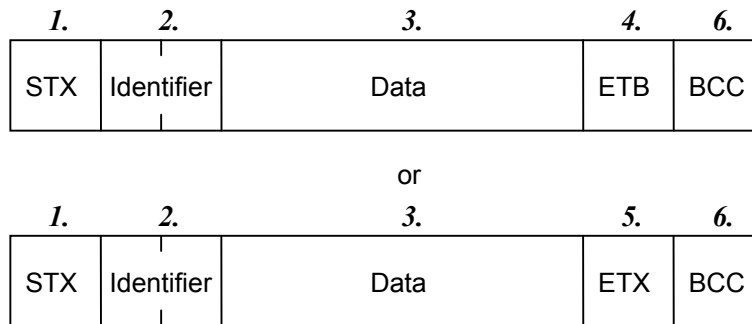

If the length of send data (from STX to BCC) exceeds 128 bytes, it is divided into blocks by ETB. In this case, the succeeding divided data is sent after STX.



Details for 1 to 6, refer to **6.1.2 Polling (P. 50)**.

(4) ACK (Acknowledgment)

An acknowledgment ACK is sent by the COM-E when data received is correct. When the host computer receives ACK from the COM-E, the host computer will send any remaining data. If there is no more data to be sent to COM-E, the host computer sends EOT to terminate the data link.

(5) NAK (Negative acknowledge)

In the following cases, the COM-E sends NAK. Then the appropriate recovery processing steps should be taken, such as resending the data on the host computer side.

- When an error occurs on the line (parity error, framing error, etc.)
- When a BCC check error occurs
- When the specified identifier is invalid
- When there is an error in the data format
- When receive data exceeds the setting range

(6) No response from SR Mini HG SYSTEM

The COM-E does not respond when it can not receive the selecting address, STX, ETB, ETX or BCC.

(7) EOT (Data link termination)

The host computer sends EOT when there is no more data to be sent from the host computer or there is no response from the COM-E.

■ Selecting procedure example (when the host computer sends data)

● Normal transmission

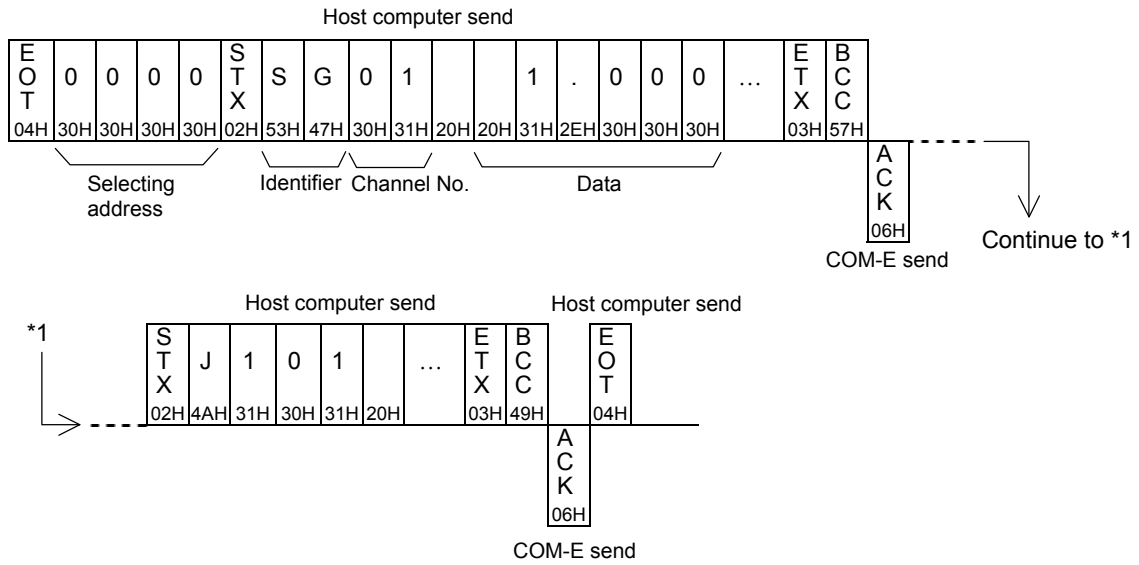

● Error transmission

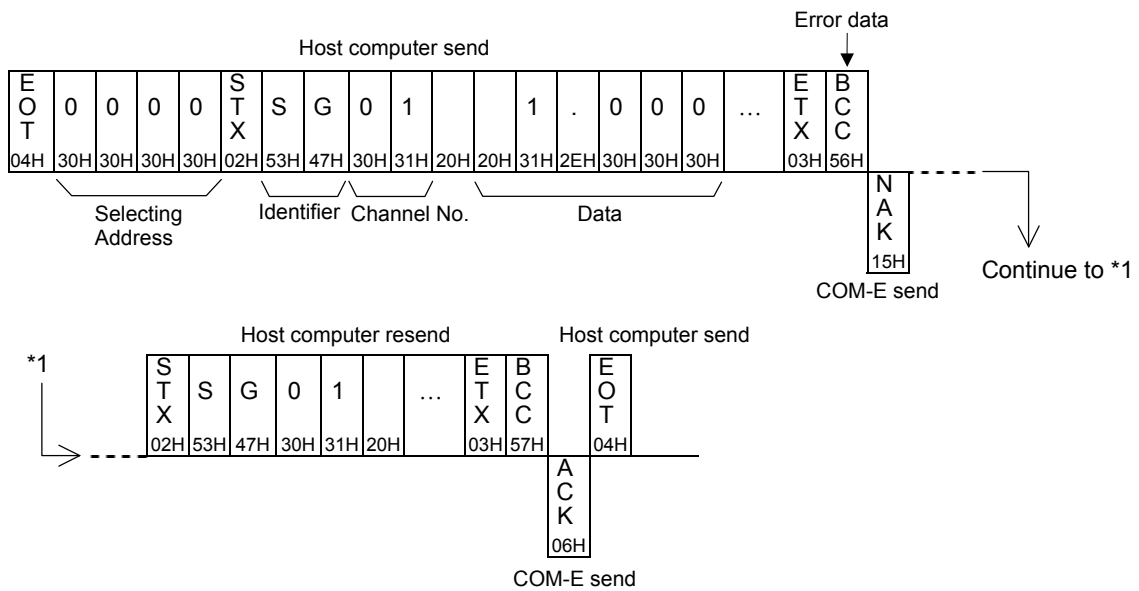

6.2 Communication Identifier List

6.2.1 LE100

(Attributes RO: Read only, R/W: Read/Write)

Name	Identifier	Digits	Attribute	Data range	Factory set value
Measured value (PV)	M1	6	RO	Within input range ¹	—
Error code ²	ER	6	RO	0: No error Except 0: Error occurs	—
Specific gravity monitor	MS	6	RO	0.800 to 2.500	—
Peak hold monitor	HP	6	RO	Scale low to Scale high	—
Bottom hold monitor	HQ	6	RO	Scale low to Scale high	—
Amount of emptiness correction monitor	MZ	6	RO	-5.00 to +5.00 of full span	—

Continued on the next page.

¹ Input Range Table

Unit setting	Unit	Range	Notes
0	mm	0 to 1250	The high limit is determined by the specific gravity setting.
1	%	0.0 to 100.0	% display of liquid level.
2	%	0.0 to 100.0	% display of pressure.
3	l	0 to 360	The decimal point position depends on the decimal point position selection.
4	m/l	0 to 360	The decimal point position depends on the decimal point position selection.
5	kPa	0 to 9.807	—
6	Pa	0 to 9807	—

² Error code

Error number	Details	Error number	Details
1	Adjusted data destruction error	64	Span adjustment execution error
2	EEPROM write error	128	Number of wafer processing times error
4	EEPROM time out error	256	Output setting by actual liquid error
8	Input capture hardware error	512	Linearizing table creation error
16	Emptiness adjustment execution error	1024	Error flag (Abnormality of instrument or communication)
32	Span setting by actual liquid error	—	—



If two or more errors occur simultaneously, the total summation of these error codes is displayed.

Continued from the previous page.

(Attributes RO: Read only, R/W: Read/Write)

Name	Identifier	Digits	Attribute	Data range	Factory set value
Output 1 set value ¹	A1	6	R/W	Scale low to Scale high	1000
Output 2 set value ¹	A2	6	R/W	Scale low to Scale high	1000
Output 3 set value ¹	A3	6	R/W	Scale low to Scale high	1000
Output 4 set value ¹	A4	6	R/W	Scale low to Scale high	1000
Emptiness adjustment	AZ	6	R/W	0: Not executed 1: Executed	0
Hold reset	HR	6	R/W	1: Executed	—
Error release	EC	6	R/W	1: Executed	—
Digital filter	F1	6	R/W	0 to 100 seconds (0: OFF)	3
Specific gravity ²	SG	6	R/W	0.800 to 2.500	1.000
Scale 1 actual liquid setting ³	J1	6	R/W	0 to 1250	0
Scale 2 actual liquid setting ³	J2	6	R/W	1 to 1250	1250
Specific gravity setting transfer ⁴	SP	6	R/W	0: Manual setting 1: Actual liquid setting	0

¹ This is the identifier effective when output type of Process high, Process low, Deviation high, or Deviation low are selected.

² This is the identifier effective when the specific gravity setting is changed to the manual setting.

³ This is the identifier effective when the specific gravity setting is changed to the actual liquid setting.

⁴ This is the identifier effective when the engineering unit is set to any unit other than % (% display of pressure), kPa or Pa.

6.2.2 RKC temperature controller

(REX-F400/700/900, CB100/400/500/700/900, SA200)

(Attributes RO: Read only, R/W: Read/Write)

Name	Identifier	Digits	Attribute	Data range	Factory set value
Measured value (PV)	M1	6	RO	Within input range	—
Set value (SV)	S1	6	R/W	Within input range	—
Error code ¹	ER	6	RO	0: No error 1024: Error flag (Abnormality of instrument or communication)	

¹ This communication identifier is the identifier that COM-E has for host communication.

7. USAGE EXAMPLE

This section describes the procedures for setting the initial values and the set values after the COM-E is purchased by referring to an example when connected to a MITSUBISHI MELSEC Q series of PLCs.

7.1 Configuration Instrument

■ System configuration

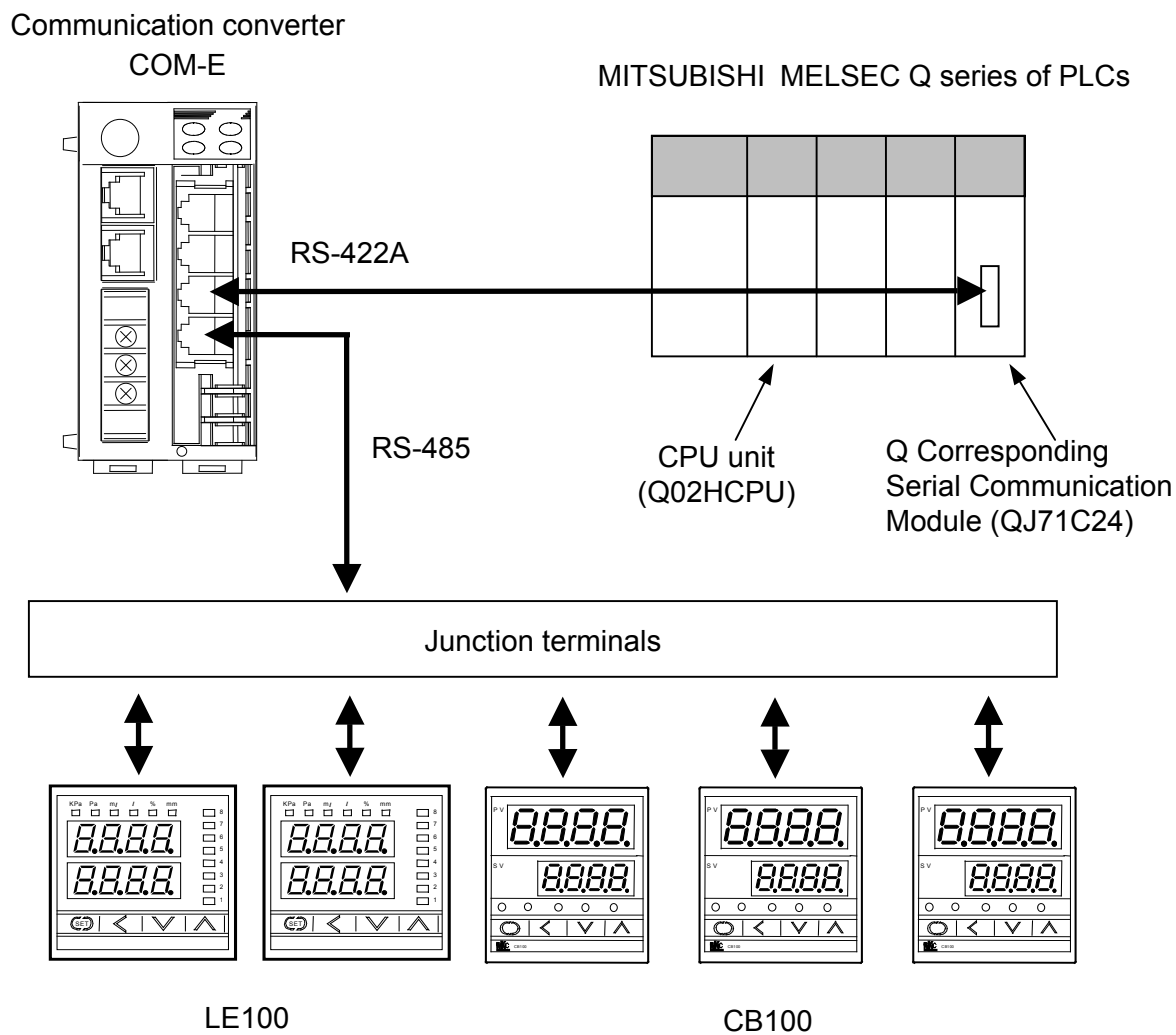

Fig.7-1 System configuration

■ Use instruments

- COM-E-02-01: 1
- RKC temperature controller
 - LE100: 2 [Communication interface RS-485]
 - CB100: 3 [Communication interface RS-485]
- MITSUBISHI MELSEC Q series of PLCs
 - CPU unit Q02HCPU: 1
 - Q Corresponding Serial Communication Module QJ71C24: 1 [Communication interface RS-422A]

■ Use cables

- Between the COM-E and PLC: 1 [W-BF-01 modular connector cable in RKC product]
- Between the COM-E and relay terminal block: 1 [W-BF-01 modular connector cable in RKC product]
- Between the RKC temperature controller and relay terminal block: 6 [No. of cables fabricated]

7.2 Handling Procedures

Conduct the handling according to the procedure described below.

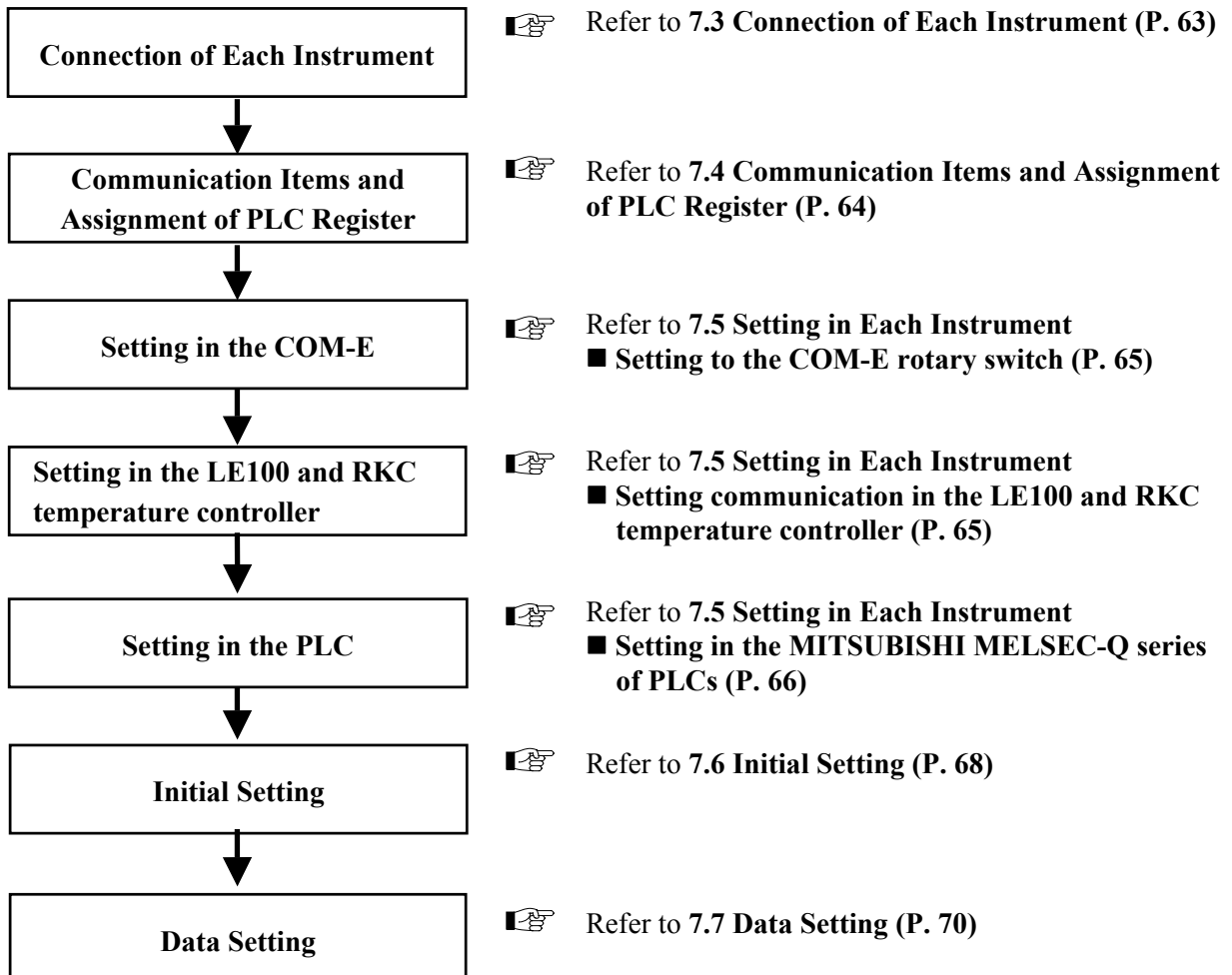

7.3 Connection of Each Instrument

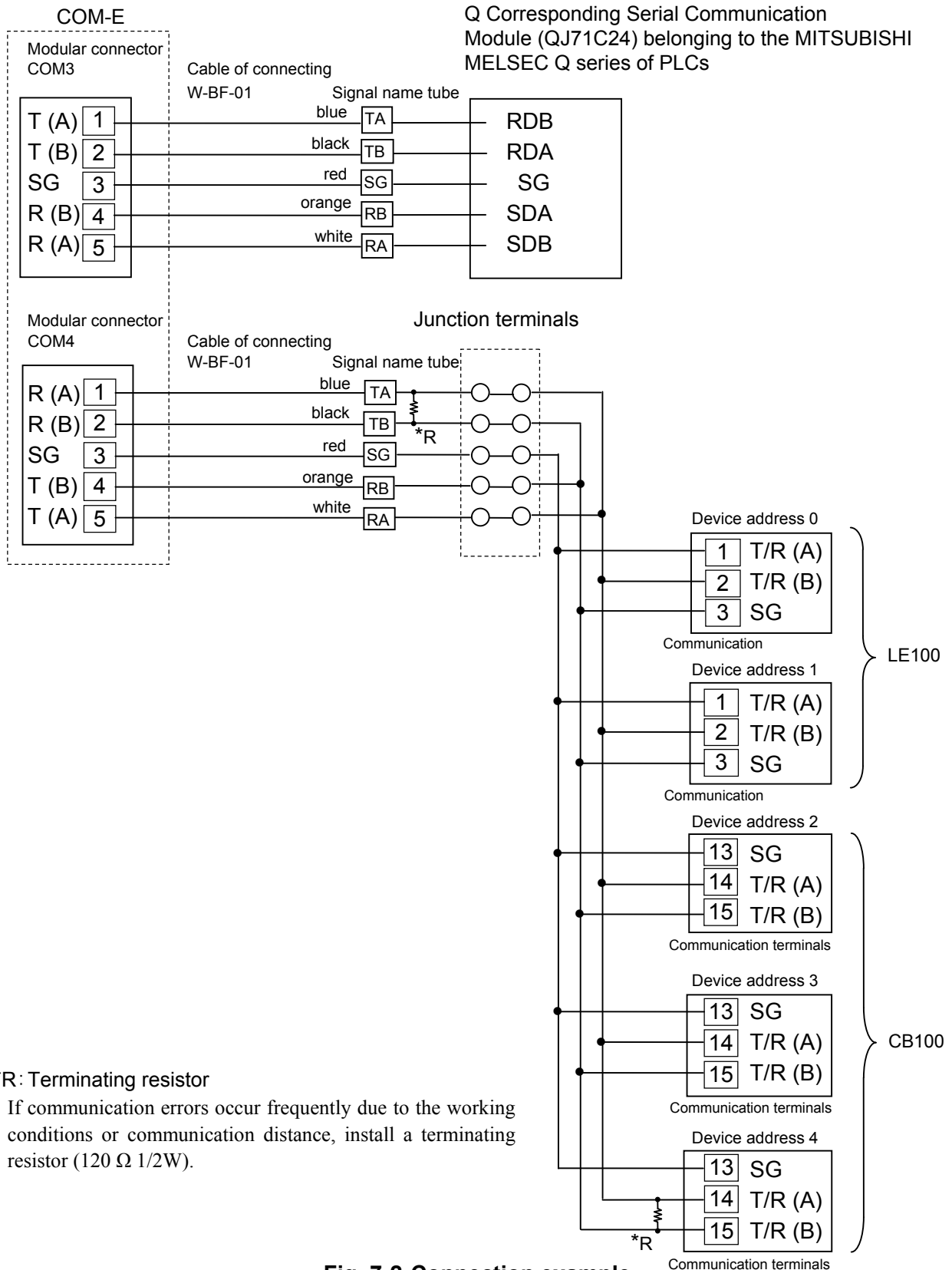

Fig. 7-2 Connection example

7.4 Communication Items and Assignment of PLC Register

The following show items communicating with our temperature controller and those assigned to the PLC register in this application example.

■ Communication items of the LE100 and RKC temperature controller

- Specific gravity
- Scale 1 actual liquid setting
- Scale 2 actual liquid setting
- Set value (SV)
- Measured value (PV)
- Alarm status
- Request command
- COM-E communication status
- The total number of LE100s and RKC temperature controllers

■ Assignment of the PLC register number

Register range to use with the PLC side is from D5500 to D5882.

Register area No.	PLC register No.	Communication items	The RKC temperature controller	
			Device address	Model
3	D5540	Specific gravity	0	LE100
	D5541	Specific gravity	1	LE100
6	D5600	Scale 1 actual liquid setting	0	LE100
	D5601	Scale 1 actual liquid setting	1	LE100
7	D5620	Scale 2 actual liquid setting	0	LE100
	D5621	Scale 2 actual liquid setting	1	LE100
13	D5742	Set value (SV)	2	CB100
	D5743	Set value (SV)	3	CB100
	D5744	Set value (SV)	4	CB100
14	D5760	Measured value (PV)	0	LE100
	D5761	Measured value (PV)	1	LE100
	D5762	Measured value (PV)	2	CB100
	D5763	Measured value (PV)	3	CB100
	D5764	Measured value (PV)	4	CB100
15	D5780	Alarm status	0	LE100
	D5781	Alarm status	1	LE100
	D5782	Alarm status	2	CB100
	D5783	Alarm status	3	CB100
	D5784	Alarm status	4	CB100
20	D5880	Request command	Common	Common
21	D5881	COM-E Communication status	Common	Common
22	D5882	The total number of LE100s and RKC temperature controllers	Common	Common



The details of communication items refer to **5.5 Communication Items List (P.39)**.

7.5 Setting in Each Instrument

Always conduct the following settings before connecting each instrument.

■ Setting to the COM-E rotary switch

As the register range used on the PLC side is from D5500 to D5899, the COM-E rotary switch is set to "9".

Setting item	Description
PLC register area	9: D5500 to D5899

(9: Factory set value)

 About setting of the COM-E rotary switch, refer to **5.1 Rotary Switch Setting (P. 30)**.

■ Setting communication in the LE100 and RKC temperature controller

● LE100

Setting item	Description
Communication speed	19200 bps
Data bit	8
Stop bit	1
Parity bit	Without
Interval time	25 ms or mores
Device address	0, 1

● CB100

Setting item	Description
Communication speed	19200 bps
Data bit	8
Stop bit	1
Parity bit	Without
Interval time	15 or mores (25 ms or more)
Device address	2, 3, 4

 For details on setting communication with the **LE100** or the RKC temperature controller, refer to the **LE100 Communication Instruction Manual (IMR01C02-E□)** or the **communication instruction manual** for the RKC temperature controller.

■ Setting in the MITSUBISHI MELSEC-Q series of PLCs

Setting item	Description
Communication speed	19200 bps
Data bit	8
Stop bit	1
Parity bit	No
Sum check code	Yes
Write during RUN	Allowed
Station number	0
Communication protocol	MC protocol Format 4



Setting in the Q Corresponding Serial Communication Module (QJ71C24) belonging to the MITSUBISHI MELSEC-Q series of PLCs do with the GX Developer of the MITSUBISHI MELSOFT series (SW□D5C-GPPW-E).

Setting set the following set value with [GX Developer] → [PLC parameters] → [I/O assignment setting] → [Switch setting].

- Switch 3: **07E2** (Hexadecimal)
- Switch 4: **0004** (Hexadecimal)
- Switch 5: **0000** (Hexadecimal)

[Setting screen]

Switch setting for I/O and intelligent functional module

Input format **HEX.**

For RS-232C For RS-485/422A

	Slot	Type	Model name	Switch1	Switch2	Switch3	Switch4	Switch5
0	PLC	PLC	Q02HCPU					
1	0 (0-0)	Inteli	QJ61BT11					
2	1 (0-1)	Inteli	QJ71C24	07EE	07EE	07E2	0004	0000
3	2 (0-2)	Input	QX42					
4	3 (0-3)	Output	QY42P					
5	4 (0-4)							
6	5 (0-5)							
7	6 (0-6)							
8	7 (0-7)							
9								
10								
11								
12								
13								
14								
15								

End Cansel **To be set.**

Continued on the next page.

Continued from the previous page.

- Description Switches 1 to 5

Switch number	Description	
Switch 1	b15 to b8	b7 to b0
	CH1 Communication rate setting	CH1 Transmission setting
Switch 2	CH1 Communication protocol setting	
Switch 3	b15 to b8	b7 to b0
	CH2 Communication rate setting	CH2 Transmission setting
Switch 4	CH2 Communication protocol setting	
Switch 5	Station number setting	

* Set the transmission specifications and communication protocol of each interface using the combinations of setting values for each switch with 16 bit binary data.

- Setting on switch 3 (CH2 Transmission setting)

Bit	Description	OFF (0)	ON (1)	Setting	Set value
b0	Operation setting *	Independent	Link	0	2
b1	Data bit	7	8	1	
b2	Parity bit	No	Yes	0	
b3	Even/Odd parity	Odd	Even	0	E
b4	Stop bit	1	2	0	
b5	Sum check code	No	Yes	1	
b6	Write during RUN	Prohibited	Allowed	1	
b7	Setting modifications	Prohibited	Allowed	1	

* Must be set to OFF (0) on CH1

- Setting on switch 3 (CH2 Communication rate setting)

Communication rate	Bit position	Communication rate	Bit position
(Unit: bps)	b15 to b8	(Unit: bps)	b15 to b8
300	00H	14400	06H
600	01H	19200	07H
1200	02H	28800	08H
2400	03H	38400	09H
4800	04H	57600	0AH
9600	05H	115200	0BH

* Set 19200 bps on communication rate. (set value: 07)

- Setting on switch 4 (CH2 Communication protocol setting)

Set number	Description	Set number	Description	
0H	GX Developer connection	6H	Non procedure protocol	
1H	MC protocol	7H	Bidirectional protocol	
2H		Format 1	8H	For linked operation setting
3H		Format 2	9H to DH	Setting prohibited
4H		Format 3	EH	ROM/RAM/switch test
5H		Format 4	FH	Individual station loopback test
	Format 5			

* Set MC protocol Format 4 on communication protocol setting. (Set value: 04)

- Setting on switch 5 (Station number setting)

This setting is common for both CH1 and CH2 sides.

When several the Q series C24s are connected on the same line with multidrop connection, set the station number designated in the data items of the transmission frame in each external device to 0 to 31 (0H to 1FH).

This number designates which external device is to be communicated with the Q series C24.

Set the station number to 0 when the system configuration of the external device and the PLC CPU is 1:1.



When more than one block is using intelligent functional modules of the serial communication module, set the interrupt pointer setting with [GX Developer] → [PLC parameters] → [PLC system setting] → [Interrupt pointer setting].



The details of setting refer to the Users Manual (Basic) for the Q Corresponding Serial Communication Module and the Operating Manual for the GX Developer.

7.6 Initial Setting



Change each set value of our LE100 and temperature controller from the PLC after the following initial settings are made. If each set value of our LE100 and temperature controller is changed from the PLC without setting the initial values, it is re-written to 0 with each set value of the PLC at that time set to 0.

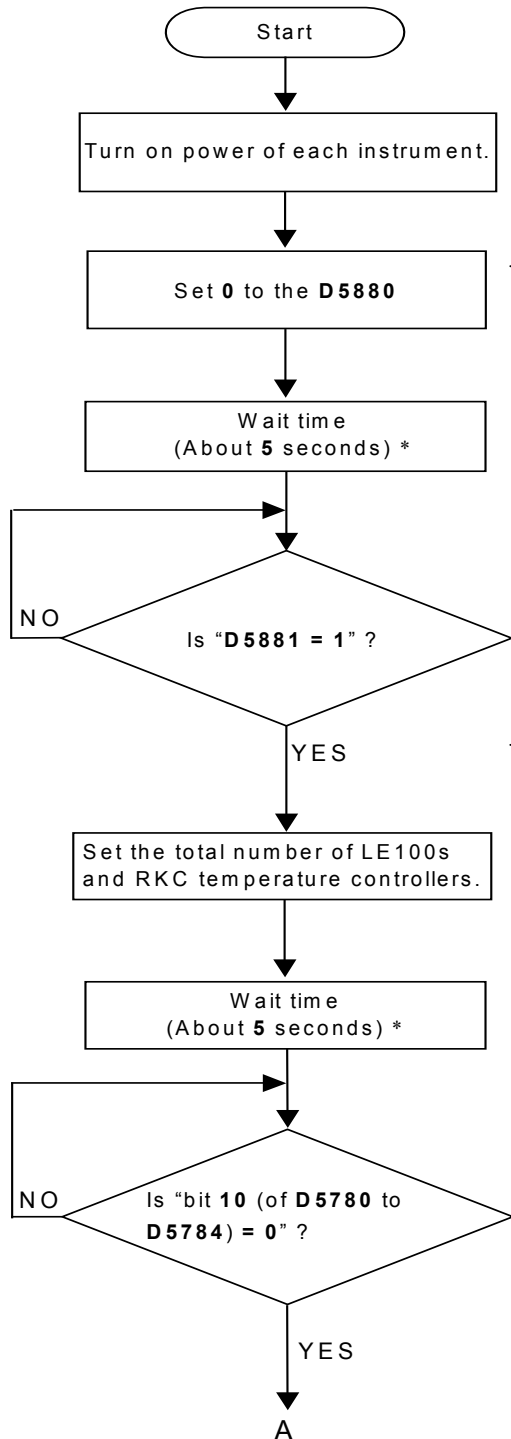

If the power is supplied simultaneously to the PLC and COM-E, the ERR indicator * on the Q Corresponding Serial Communication Module (QJ71C24) side of the PLC lights.

This is because the COM-E sends the BRK (break) signal to the PLC for about 10 seconds, but not abnormal.

* When the ERR indicator turn on once, it is held.

For details of error reset, refer to the Users Manual (Basic) for the Q Corresponding Serial Communication Module and the Operating Manual for the GX Developer.

Checking communication

If 1 (writing on monitor data) is set to **D5881** (COM-E communication status) the wait time after 0 (monitor) is set to **D5880** (request command) in the PLC, our LE100 and temperature controller communicates normally with the PLC to indicate that our LE100 data items such as measured values, etc. (attribute: RO) are being written into the PLC.

Sets the total number of LE100s and RKC temperature controllers used in this system.

[Example]

Set 5 (for 5 instruments) to **D5882** (the total number of LE100s and RKC temperature controllers) in the PLC.

If bit 10 (error flag) of **D5780** to **D5784** (alarm status) in the PLC corresponds to 0 (normality), this indicates that each instrument is normal.

* Spend a wait time of about 5 second (1 second/controller) after being set. In addition, process data in each item as indefinite during this period.

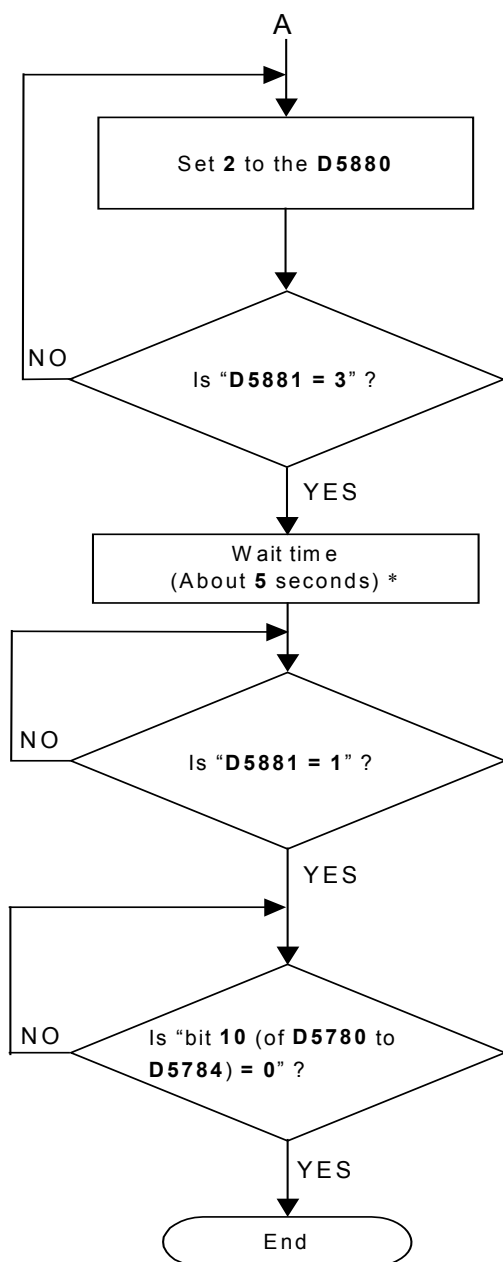

Our LE100 set data items such as present specific gravity, etc. (attribute: RW) are written into the PLC by setting **2** (set value monitor) to **D5880** (Request command) in the PLC.

If **3** (writing on setting data) is set to **D5881** (COM-E communication status) in the PLC, this indicates that our LE100 set data items such as present specific gravity, etc. (attribute: RW) are being written into the PLC.

If **1** (writing on monitor data) is set to **D5881** (COM-E communication status) in the PLC, this indicates that our LE100 set data items such as present specific gravity, etc. (attribute: RW) have been written to start writing our LE100 data items such as measured values, etc. (attribute: RO) into the PLC.

If bit **10** (error flag) of **D5780** to **D5784** (alarm status) in the PLC corresponds to **0** (normality), this indicates that each instrument is normal.

* Spend a wait time of about 5 second (1 second/controller) after being set. In addition, process data in each item as indefinite during this period.



The same setting procedure applies when other PLCs are also use.



It is desirable to do confirmation of communication regularly in usual communication, if any one of **1** (writing on monitor data), **2** (reading out setting data) and **3** (writing on setting data) is set to **D5881** (COM-E communication status) the wait time after **0** (communication failure) is set to **D5881** (COM-E communication status) in the PLC, our LE100 and temperature controller communicates normally with the PLC. In addition, it is necessary to confirm the description of front with initial setting level at having done restart because there is an object of memorizing status before cutting it off by PLC.

7.7 Data Setting

It is assumed that initial setting is finished.



If each set value of our LE100 and temperature controller is changed from the PLC without setting the initial values, it is re-written to 0 with each set value of the PLC at that time set to 0.

■ Setting example

When setting our LE100 specific gravity and temperature controller temperature set value (SV) as follows:

Specific gravity at address 0 (LE100) = 1.000

Specific gravity at address 1 (LE100) = 1.100

Temperature set value (SV) at address 2 (CB100) = 100

Temperature set value (SV) at address 3 (CB100) = 110

Temperature set value (SV) at address 4 (CB100) = 120

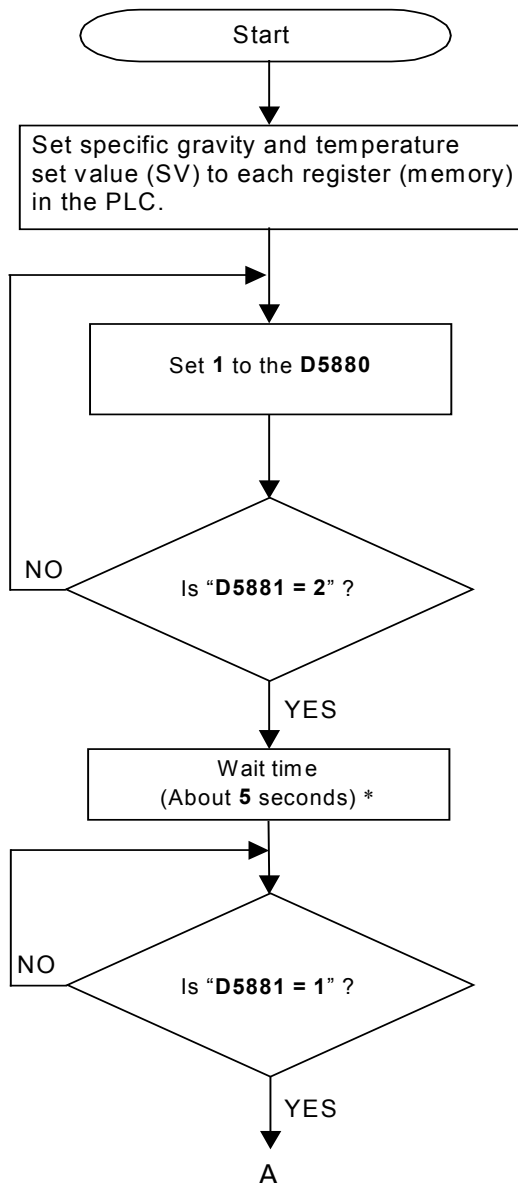

PLC register number	Specific gravity and Set value (SV)	The RKC instrument	
		Device address	Model
D5540	1.000	0	LE100
D5541	1.100	1	LE100
D5742	100	2	CB100
D5743	110	3	CB100
D5744	120	4	CB100

Set data items such as specific gravity, etc. (attribute: RW) set to the register on the PLC side (memory) are read from the PLC by setting 1 (setting) to D5880 (request command) in the PLC.

If 2 (reading out setting data) is set to D5881 (COM-E communication status) in the PLC, this indicates that set data items such as specific gravity, etc. (attribute: RW) are being read from the PLC.

* Spend a wait time of about 5 second (1 second/controller) after being set. In addition, process data in each item as indefinite during this period.

If 1 (writing on monitor data) is set to D5881 (COM-E communication status) in the PLC, this indicates that our LE100 set data items such as present specific gravity, etc. (attribute: RW) have been written to start writing our LE100 data items such as measured values, etc. (attribute: RO) into the PLC.

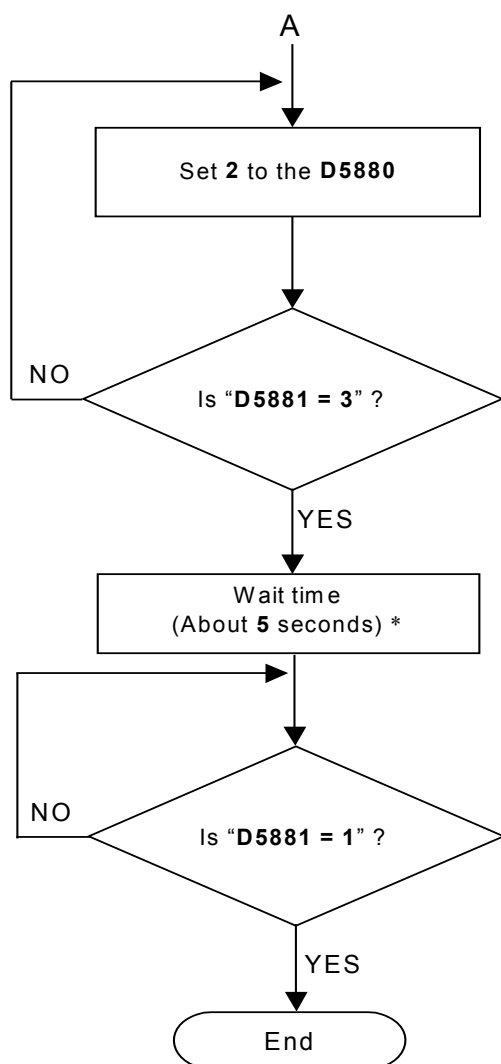

Our LE100 set data items such as present specific gravity, etc. (attribute: RW) are written into the PLC by setting **2** (set value monitor) to **D5880** (Request command) in the PLC.

If **3** (writing on setting data) is set to **D5881** (COM-E communication status) in the PLC, this indicates that our LE100 set data items such as present specific gravity, etc. (attribute: RW) are being written into the PLC.

* Spend a wait time of about 5 second (1 second/controller) after being set. In addition, process data in each item as indefinite during this period.

If **1** (writing on monitor data) is set to **D5881** (COM-E communication status) in the PLC, this indicates that our LE100 set data items such as present specific gravity, etc. (attribute: RW) have been written to start writing our LE100 data items such as measured values, etc. (attribute: RO) into the PLC.



The same setting procedure applies when other PLCs are also use.



For the communication status check, refer to the ■ **Communication status check procedures** of **5.4.2 Communication status check (P. 37)**.

8. TROUBLESHOOTING

This section explains probable causes and treatment procedures if any abnormality occurs in the instrument. For any inquiries, please contact RKC sales office or the agent, to confirm the specifications of the product.

If it is necessary to replace a device, always strictly observe the warnings below.



WARNING

- To prevent electric shock or instrument failure, always turn off the system power before replacing the instrument.
- To prevent electric shock or instrument failure, always turn off the power before mounting or removing the instrument.
- To prevent electric shock or instrument failure, do not turn on the power until all wiring is completed. Make sure that the wiring is correct before applying power to the instrument.
- To prevent electric shock or instrument failure, do not touch the inside of the instrument.
- All wiring must be performed by authorized personnel with electrical experience in this type of work.

CAUTION

All wiring must be completed before power is turned on to prevent electric shock, instrument failure, or incorrect action.

■ COM-E

Problem	Possible cause	Solution
Operation lamp 1 does not flash (Host communication is operating)	Wrong connection, no connection or disconnection of the communication cable	Confirm the connection method or condition and connect correctly
	Breakage, wrong wiring, or imperfect contact of the communication cable	Confirm the wiring or connector and repair or replace the wrong one
	CPU section defect	Replace COM-E
Operation lamp 2 does not flash (Operation panel communication is operating)	Wrong connection, no connection or disconnection of the communication cable	Confirm the connection method or condition and connect correctly
	Breakage, wrong wiring, or imperfect contact of the communication cable	Confirm the wiring or connector and repair or replace the wrong one
	CPU section defect	Replace COM-E
Operation lamp 3 does not flash (PLC communication is operating)	Power not being supplied	Check external breaker etc.
	Appropriate power supply voltage not being supplied	Check the power supply
	Power supply terminal contact defect	Retighten the terminals
	Power supply section defect	Replace COM-E
Operation lamp 3 does not flash (Controllers communication is operating)	Power not being supplied	Check external breaker etc.
	Appropriate power supply voltage not being supplied	Check the power supply
	Power supply terminal contact defect	Retighten the terminals
	Power supply section defect	Replace COM-E
All Operation lamp light up	CPU section defect FAIL status of COM-E	Replace COM-E

■ PLC communication

Problem	Possible cause	Solution
The register (COM-E communication status) of the PLC side is "0: Communication failure"	Wrong connection, no connection or disconnection of the communication cable	Confirm the connection method or condition and connect correctly
	Breakage, wrong wiring, or imperfect contact of the communication cable	Confirm the wiring or connector and repair or replace the wrong one
	Mismatch of the setting data of communication speed, data bit configuration and protocol with those of the PLC	Confirm the PLC settings and set them correctly
	Wrong setting of the PLC communication data	Confirm the PLC settings and set them correctly Setting of termination resistor in accordance with the PLC or the insertion is done
Though request command is set in "1: Setting," set value of the RKC temperature controller does not change	Data rang error	Confirm the setting range of set value and set them correctly
	The operation mode has not been switched to the Computer mode (COMP). [For REX-F400/700/900 (RKC product)]	Switch the operation mode of the REX-F400/700/900 to Computer mode (COMP).
If the power is supplied simultaneously to the PLC and COM-E, the ERR indicator on the Q Corresponding Serial Communication Module (QJ71C24) side of the PLC lights.	This is because the COM-E sends the BRK (break) signal to the PLC for about 10 seconds, but not abnormal.	When the ERR indicator turn on once, it is held. For details of error reset, see the Users Manual (Basic) for the Q Corresponding Serial Communication Module and the Operating Manual for the GX Developer.

■ Host communication

Problem	Possible cause	Solution
No response	Wrong connection, no connection or disconnection of the communication cable	Confirm the connection method or condition and connect correctly
	Breakage, wrong wiring, or imperfect contact of the communication cable	Confirm the wiring or connector and repair or replace the wrong one
	Mismatch of the setting data of communication speed and data bit configuration with those of the host	Confirm the settings and set them correctly
	Wrong address setting	
	Error in the data format	Reexamine the communication program
	Transmission line is not set to the receive state after data send (for RS-485)	
EOT return	The specified identifier is invalid	Confirm the identifier is correct or that with the correct function is specified. Otherwise correct it
	Error in the data format	Reexamine the communication program
NAK return	Error occurs on the line (parity bit error, framing error, etc.)	Confirm the cause of error, and solve the problem appropriately. (Confirm the transmitting data, and resend data)
	BCC error	
	The data exceeds the setting range	Confirm the setting range and transmit correct data
	The block data length of the transmission exceeds 128 bytes	Divide the block using ETB before sending it
	The specified identifier is invalid	Confirm the identifier is correct or that with the correct function is specified. Otherwise correct it
	The transmission mode of the operation panel is set to local mode (When the operation panel is REX-F400/700/900)	Change to computer mode (When the operation panel is REX-F400/700/900)

9. ASCII 7-BIT CODE TABLE

					b7	0	0	0	0	1	1	1	1
					b6	0	0	1	1	0	0	1	1
					b5	0	1	0	1	0	1	0	1
b5~b7	b4	b3	b2	b1		0	1	2	3	4	5	6	7
	0	0	0	0	0	NUL	DLE	SP	0	@	P	'	p
	0	0	0	1	1	SOH	DC1	!	1	A	Q	a	q
	0	0	1	0	2	STX	DC2	”	2	B	R	b	r
	0	0	1	1	3	ETX	DC3	#	3	C	S	c	s
	0	1	0	0	4	EOT	DC4	\$	4	D	T	d	t
	0	1	0	1	5	ENQ	NAK	%	5	E	U	e	u
	0	1	1	0	6	ACK	SYM	&	6	F	V	f	v
	0	1	1	1	7	BEL	ETB	'	7	G	W	g	w
	1	0	0	0	8	BS	CAN	(8	H	X	h	x
	1	0	0	1	9	HT	EM)	9	I	Y	i	y
	1	0	1	0	A	LF	SUB	*	:	J	Z	j	z
	1	0	1	1	B	VT	ESC	+	;	K	[k	{
	1	1	0	0	C	FF	FS	,	<	L	¥	l	
	1	1	0	1	D	CR	GS	-	=	M]	m	}
	1	1	1	0	E	SO	RS	.	>	N	^	n	~
	1	1	1	1	F	SI	US	/	?	O	_	o	DEL



RKC INSTRUMENT INC.

HEADQUARTERS: 16-6, KUGAHARA 5-CHOME, OHTA-KU TOKYO 146-8515 JAPAN

PHONE: 03-3751-9799 (+81 3 3751 9799)

FAX: 03-3751-8585 (+81 3 3751 8585)

E-mail: info@rkcinst.co.jp

Website: <http://www.rkcinst.com/>