

Module Type Controller SRX

Temperature Control Module [Basic Type]

X-TIO-A

Instruction Manual

IMS01N02-E5

Thank you for purchasing this RKC product. In order to achieve maximum performance and ensure proper operation of your new instrument, carefully read all the instructions in this manual. Please place the manual in a convenient location for easy reference.

SYMBOLS

WARNING : This mark indicates precautions that must be taken if there is danger of electric shock, fire, etc., which could result in loss of life or injury.

CAUTION : This mark indicates that if these precautions and operating procedures are not taken, damage to the instrument may result.



: This mark indicates that all precautions should be taken for safe usage.



: This mark indicates important information on installation, handling and operating procedures.



: This mark indicates supplemental information on installation, handling and operating procedures.



: This mark indicates where additional information may be located.



WARNING

- To prevent injury to persons, damage to instrument and equipment, a suitable external protection device shall be required.
- All wiring must be completed before power is turned on to prevent electric shock, fire or damage to instrument and equipment.
- This instrument must be used in accordance with the specifications to prevent fire or damage to instrument and equipment.
- This instrument is not intended for use in locations subject to flammable or explosive gases.
- Do not touch high-voltage connections such as power supply terminals, etc. to avoid electric shock.
- RKC is not responsible if this instrument is repaired, modified or disassembled by other than factory-approved personnel. Malfunction can occur and warranty is void under these conditions.

CAUTION

- This product is intended for use with industrial machines, test and measuring equipment. (It is not designed for use with medical equipment and nuclear energy.)
- This is a Class A instrument. In a domestic environment, this instrument may cause radio interference, in which case the user may be required to take additional measures.
- This instrument is protected from electric shock by reinforced insulation. Provide reinforced insulation between the wire for the input signal and the wires for instrument power supply, source of power and loads.

- Be sure to provide an appropriate surge control circuit respectively for the following:
 - If input/output or signal lines within the building are longer than 30 meters.
 - If input/output or signal lines leave the building, regardless the length.
- This instrument is designed for installation in an enclosed instrumentation panel. All high-voltage connections such as power supply terminals must be enclosed in the instrumentation panel to avoid electric shock by operating personnel.
- All precautions described in this manual should be taken to avoid damage to the instrument or equipment.
- All wiring must be in accordance with local codes and regulations.
- All wiring must be completed before power is turned on to prevent electric shock, instrument failure, or incorrect action. The power must be turned off before repairing work for input break and output failure including replacement of sensor, contactor or SSR, and all wiring must be completed before power is turned on again.
- To prevent instrument damage as a result of failure, protect the power line and the input/output lines from high currents with a suitable overcurrent protection device with adequate breaking capacity such as fuse, circuit breaker, etc.
- Prevent metal fragments or lead wire scraps from falling inside instrument case to avoid electric shock, fire or malfunction.
- Tighten each terminal screw to the specified torque found in the manual to avoid electric shock, fire or malfunction.
- For proper operation of this instrument, provide adequate ventilation for heat dispensation.
- Do not connect wires to unused terminals as this will interfere with proper operation of the instrument.
- Turn off the power supply before cleaning the instrument.
- Do not use a volatile solvent such as paint thinner to clean the instrument. Deformation or discoloration will occur. Use a soft, dry cloth to remove stains from the instrument.
- To avoid damage to instrument display, do not rub with an abrasive material or push front panel with a hard object.
- When high alarm with hold action/re-hold action is used for Event function, alarm does not turn on while hold action is in operation. Take measures to prevent overheating which may occur if the control device fails.

NOTICE

- This manual assumes that the reader has a fundamental knowledge of the principles of electricity, process control, computer technology and communications.
- The figures, diagrams and numeric values used in this manual are only for purpose of illustration.
- RKC is not responsible for any damage or injury that is caused as a result of using this instrument, instrument failure or indirect damage.
- RKC is not responsible for any damage and/or injury resulting from the use of instruments made by imitating this instrument.
- Periodic maintenance is required for safe and proper operation of this instrument. Some components have a limited service life, or characteristics that change over time.
- Every effort has been made to ensure accuracy of all information contained herein. RKC makes no warranty expressed or implied, with respect to the accuracy of the information. The information in this manual is subject to change without prior notice.
- No portion of this document may be reprinted, modified, copied, transmitted, digitized, stored, processed or retrieved through any mechanical, electronic, optical or other means without prior written approval from RKC.

1. OUTLINE

One temperature control (TIO) module [basic type] enables temperature control corresponding to two channels. It has power supply and host communication terminals in addition to temperature control input and output terminals. The temperature control (TIO) module [basic type] can be connected with the temperature control (TIO) module [extension type], the digital input (DI) module and the digital output (DO) module.

 All data are set by communication. For details, refer to the **Module Type Controller SRX Communication Instruction Manual (IMS01N01-E□)**.

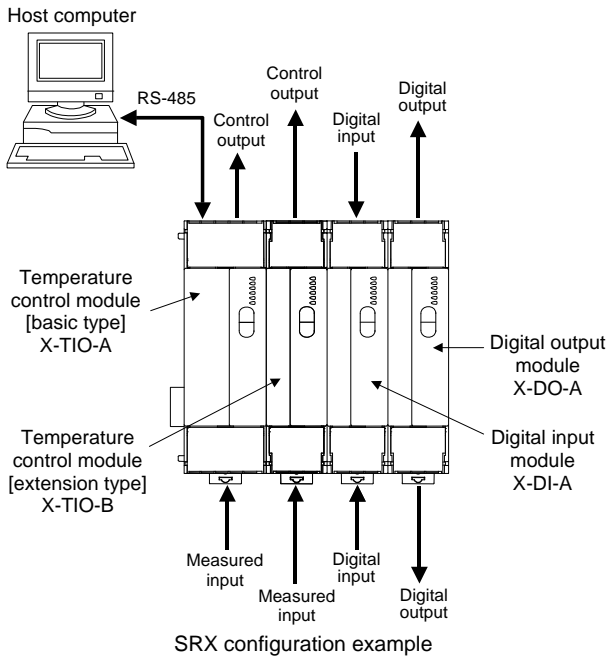

2. PRODUCT CHECK

Before using this product, check each of the following:

- Model code
- Check that all of the accessories delivered are complete.
- Check that there are no scratch or breakage in external appearance (case, front panel, or terminal, etc).

X-TIO-A- □ □ - □ □ * □ □ /Y
 (1) (2) (3) (4) (5) (6) (7) (8)

(1) Type

A: Basic type (20 terminals)

(2) Input channel 1, (3) Input channel 2

- | | | | |
|------------------|---------------|---------|---------|
| K: TC K | J: TC J | T: TC T | S: TC S |
| R: TC R | A: TC PLII | N: TC N | E: TC E |
| W: TC W5Re/W26Re | B: TC B | | |
| D: RTD Pt100 | P: RTD JPt100 | | |
- | | | |
|------------------|-------------------|----------------|
| 1: 0 to 10 mV DC | 2: 0 to 100 mV DC | 3: 0 to 1 V DC |
| 4: 0 to 5 V DC | 5: 0 to 10 V DC | 6: 1 to 5 V DC |
| 7: 0 to 20 mA DC | 8: 4 to 20 mA DC | |

(4) Control output 1, (5) Control output 2

- | | | |
|-------------------------|-----------------------------------|----------------|
| M: Relay contact output | V: Voltage pulse output 0/12 V DC | |
| 4: 0 to 5 V DC | 5: 0 to 10 V DC | 6: 1 to 5 V DC |
| 7: 0 to 20 mA DC | 8: 4 to 20 mA DC | |

(6) CT1 input, (7) CT2 input

- N: None P: CTL-6-P-N S: CTL-12-S56-10L-N

(8) Version symbol

- No code: For Japanese domestic market
 /Y: For International market

 **Heater break alarm (HBA) function cannot be used when control output is Voltage/Current output.**

■ Accessories

End Plate.....	2
Joint connector cover.....	2
X-TIO-A Instruction Manual (IMS01N02-E5).....	1

3. PARTS DESCRIPTION

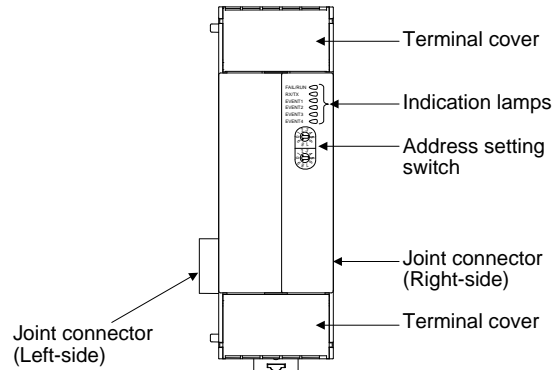

[Indication lamps]

- FAIL/RUN
 When normally: A green lamp turns on (RUN)
 When abnormally: A red lamp turns on (FAIL)
 - RX/TX
 During data send and receive: A green lamp turns on
 - EVENT 1 to 4
 Display various states by setting.
 During ON state: A green lamp turns on
- Display contents
 Event 1 state, Event 2 state, Comprehensive event state, Output state, Control state, Executing segment state, Time signal state

4. COMMUNICATION SETTING

Set communication setting before mounting and wiring of SRX.

CAUTION

Do not separate the module mainframe from the terminal base with the power turned on. If so, instrument failure may result.

4.1 Module Address Setting

Set an address of module. For this setting, use a small slotted screwdriver.

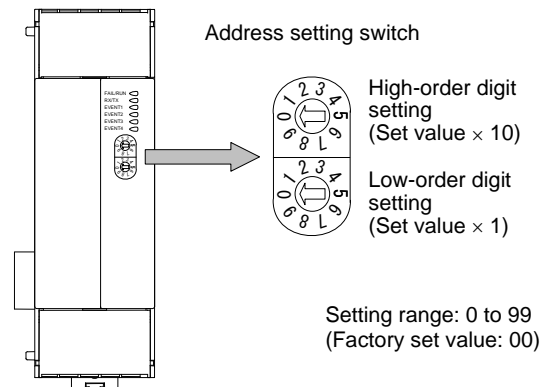

- For Modbus, the value obtained by adding "1" to the set address corresponds to the address used for the actual program.
- To avoid problems or malfunction, do not duplicate an address on the same communication line.

4.2 Protocol Selections and Communication Speed Setting

Use the DIP switch on the right side of module to select communication speed, data bit configuration, protocol and termination resistor of internal data bus. The data changes become valid when the power is turned on again or when changed to RUN/STOP.

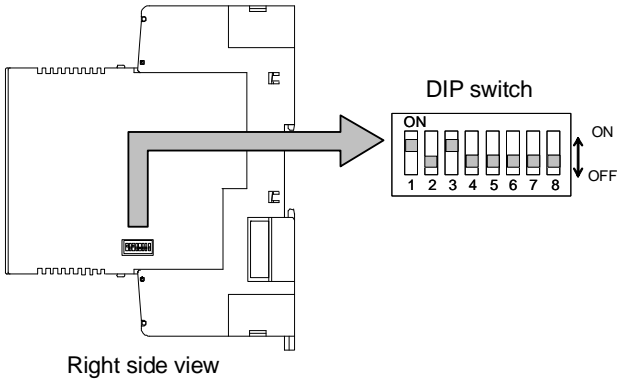

1	2	Communication speed
OFF	OFF	2400 bps
ON	OFF	9600 bps
OFF	ON	19200 bps
ON	ON	38400 bps

Factory set value: 9600 bps

3	4	5	Data bit configuration
OFF	OFF	OFF	Data 7-bit, without parity, Stop 1-bit *
OFF	OFF	ON	Data 7-bit, Even parity, Stop 1-bit *
OFF	ON	ON	Data 7-bit, Odd parity, Stop 1-bit *
ON	OFF	OFF	Data 8-bit, without parity, Stop 1-bit
ON	OFF	ON	Data 8-bit, Even parity, Stop 1-bit
ON	ON	ON	Data 8-bit, Odd parity, Stop 1-bit

* When the Modbus communication protocol is selected, this setting becomes invalid.

Factory set value: Data 8-bit, without parity

6	Protocol selection
OFF	RKC communication
ON	Modbus

Factory set value: RKC communication

8	Internal data bus termination resistor setting
OFF	Termination resistor OFF
ON	Termination resistor ON

Factory set value: Termination resistor ON



- **Switch No. 7 must be always OFF. Do not set to ON.**
- **When two or more modules are connected on the same communication line, the DIP switch settings (switch 1 to 6) of all modules must be the same. In addition, always turn on the switch, 8 (with the internal bus termination resistance connected) in module of both ends.**
- **Be changed into communication time setting mode by using switch No. 4, 5 and 6.**



For communication time setting mode, refer to the **Module Type Controller SRX Communication Instruction Manual (IMS01N01-E0)**.

5. MOUNTING



WARNING

To prevent electric shock or instrument failure, always turn off the power before mounting or removing the instrument.

5.1 Mounting Cautions

- (1) This instrument is intended to be used under the following environmental conditions. **(IEC61010-1)**
[OVERVOLTAGE CATEGORY II, POLLUTION DEGREE 2]
- (2) Use this instrument within the following environment conditions:
 - Allowable ambient temperature: -10 to +50 °C
 - Allowable ambient humidity: 5 to 95 % RH (Absolute humidity: MAX. W. C 29 g/m³ dry air at 101.3 kPa)
 - Installation environment conditions: Indoor use
Altitude up to 2000 m
- (3) Avoid the following when selecting the mounting location:
 - Rapid changes in ambient temperature, which may cause condensation.
 - Corrosive or inflammable gases.
 - Direct vibration or shock to the mainframe.
 - Water, oil, chemicals, vapor or steam splashes.
 - Excessive dust, salt or iron particles.
 - Excessive induction noise, static electricity, magnetic fields or noise.
 - Direct air flow from an air conditioner.
 - Exposure to direct sunlight.
 - Excessive heat accumulation.
- (4) Mount this instrument in the panel considering the following conditions:
 - Provide adequate ventilation space so that heat does not build up.
 - Do not mount this instrument directly above equipment that generates large amount of heat (heaters, transformers, semi-conductor functional devices, large-wattage resistors.)
 - If the ambient temperature rises above 50 °C, cool this instrument with a forced air fan, cooler, etc. Cooled air should not blow directly on this instrument.
 - In order to improve safety and the immunity to withstand noise, mount this instrument as far away as possible from high voltage equipment, power lines, and rotating machinery.
 - High voltage equipment: Do not mount within the same panel.
 - Power lines: Separate at least 200 mm.
 - Rotating machinery: Separate as far as possible.
 - Ensure at least 50 mm space on top and bottom of the control unit for maintenance and environmental reasons.
- (5) In case this instrument is connected to a supply by means of a permanent connection, a switch or circuit-breaker shall be included in the installation. This shall be in close proximity to the equipment and within easy reach of the operator. It shall be marked as the disconnecting device for the equipment.

5.2 Dimensions

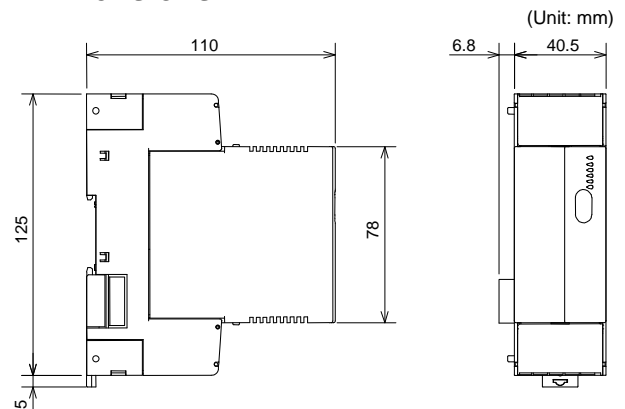

5.3 DIN rail Mounting

■ Mounting procedures

1. Pull down the mounting bracket at the bottom of the module (A). Attach the hooks on the top of the module to the DIN rail and push the lower section into place on the DIN rail (B).

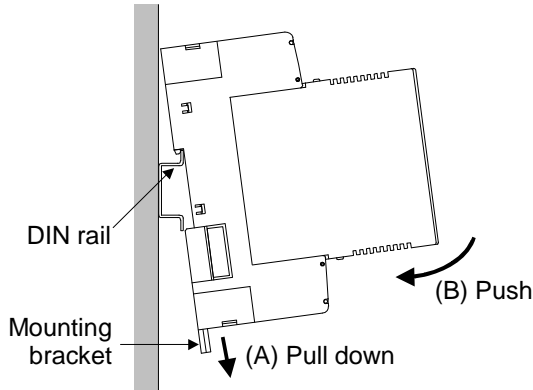

2. Slide the mounting bracket up to secure the module to the DIN rail.

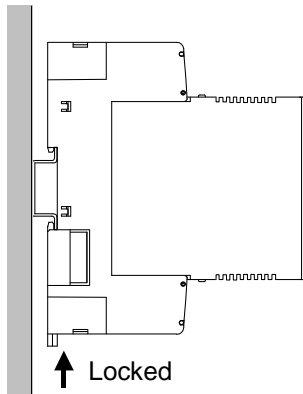

■ End Plate mounting

Hold tight both ends of the modules joined together with the end plates and then fix the end plates with screws. Even if only one temperature control module [basic type] is used, also hold tight both ends of the module with the end plates.

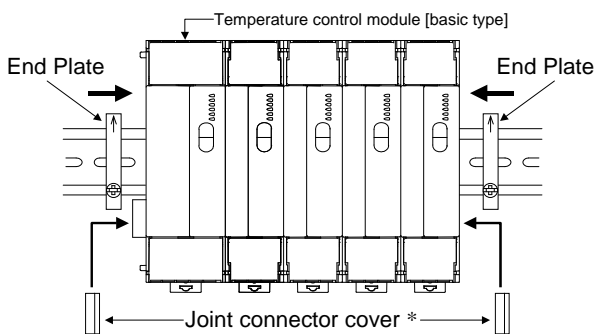

* For the conservation of the contact of connector, install a joint connector cover in module of both ends.

■ Removing procedures

Pull down a mounting bracket with a slotted screwdriver (A). Lift the module from bottom, and take it off (B).

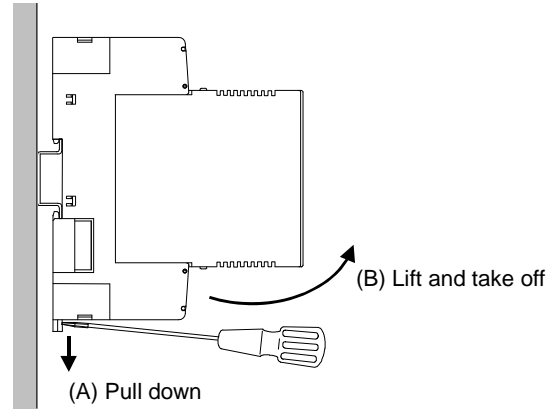

5.4 Panel Mounting

■ Mounting procedures

1. Pull down the mounting bracket (A) until locked and that a mounting hole appears.
2. Prepare one mounting bracket per module (B) sold separately (KSRX-55) and then insert it in the rear of the terminal board at top of the module until locked but a mounting hole does not disappear.
3. Mount each module directly on the panel with screws which are inserted in the mounting holes of the top and bottom mounting brackets.

Recommended tightening torque: 0.3 N·m (3 kgf·cm)



The customer needs to provide the M3 size screws. Select the screw length that matches the mounting panel.

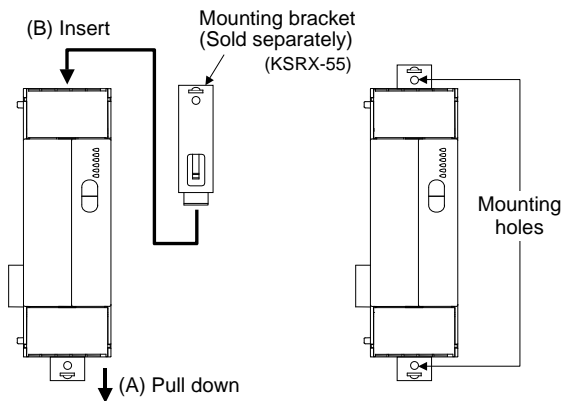

Mounting dimensions

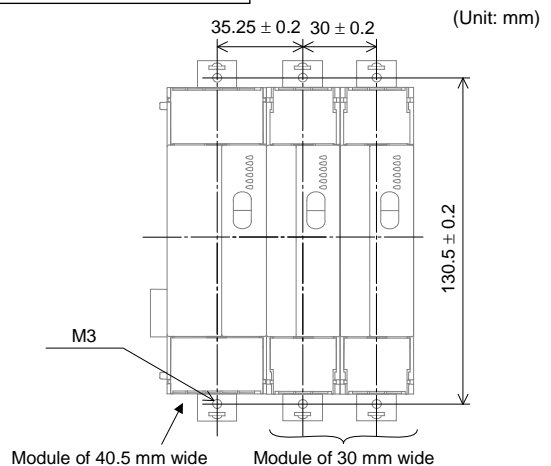

5.5 Jointing Each Module

Up to 31 SRXs consisting of the each module can be jointed together. Joint these modules according to the following procedure.

■ Jointing procedure

1. Mount the modules on the DIN rail and then joint these modules together with the joint connector while sliding the relevant module.
2. Lift each of the joint tabs located at the top and bottom of the module and then insert it in the slot of the adjacent module to fix these two modules.

 For panel mounting, first joint each module and then mount it on the panel.

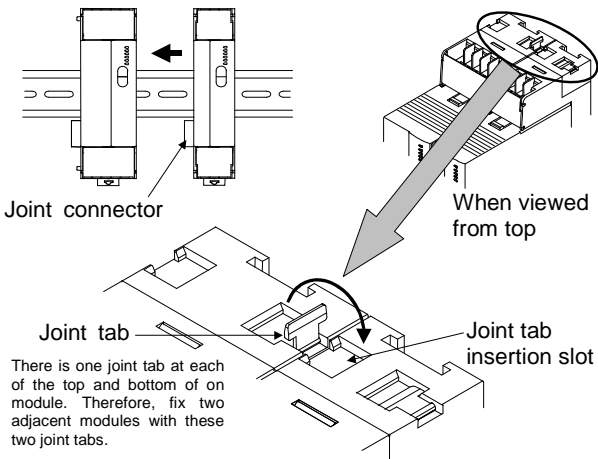

6. WIRING



WARNING

To prevent electric shock or instrument failure, do not turn on the power until all wiring is completed. Make sure that the wiring is correct before applying power to the instrument.

6.1 Wiring Cautions

- For thermocouple input, use the appropriate compensation wire.
- For RTD input, use low resistance lead wire with no difference in resistance between the three lead wires.
- To avoid noise induction, keep input signal wire away from instrument power line, load lines and power lines of other electric equipment.
- Signal connected to Voltage input and Current input shall be low voltage defined as "SELV" circuit per IEC 60950-1.
- If there is electrical noise in the vicinity of the instrument that could affect operation, use a noise filter.
 - Shorten the distance between the twisted power supply wire pitches to achieve the most effective noise reduction.
 - Always install the noise filter on a grounded panel. Minimize the wiring distance between the noise filter output and the instrument power supply terminals to achieve the most effective noise reduction.
 - Do not connect fuses or switches to the noise filter output wiring as this will reduce the effectiveness of the noise filter.

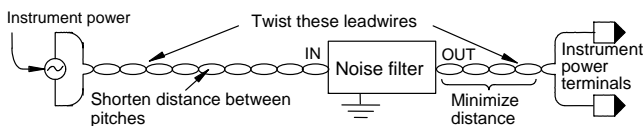

- Power supply wiring must be twisted and have a low voltage drop.

- For an instrument with 24 V power supply input, supply power from "SELV" circuit defined as IEC 60950-1.
- A suitable power supply should be considered in the end-use equipment. The power supply must be in compliance with a limited-energy circuits (maximum available current of 8 A).
- In the maximum configuration (extension up to 31 modules) the 24 V DC supplied equipment may draw up to 4 A. The power supply shall be capable of delivering at least 4 A.
- Use the solderless terminal appropriate to the screw size.
 - Screw size: M3 x 6
 - Recommended tightening torque: 0.4 N·m [4 kgf·cm]
 - Specified solderless terminals: With isolation

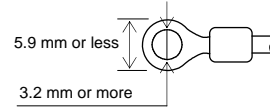

- Make sure that during field wiring parts of conductors cannot come into contact with adjacent conductive parts.

6.2 Terminal Configuration

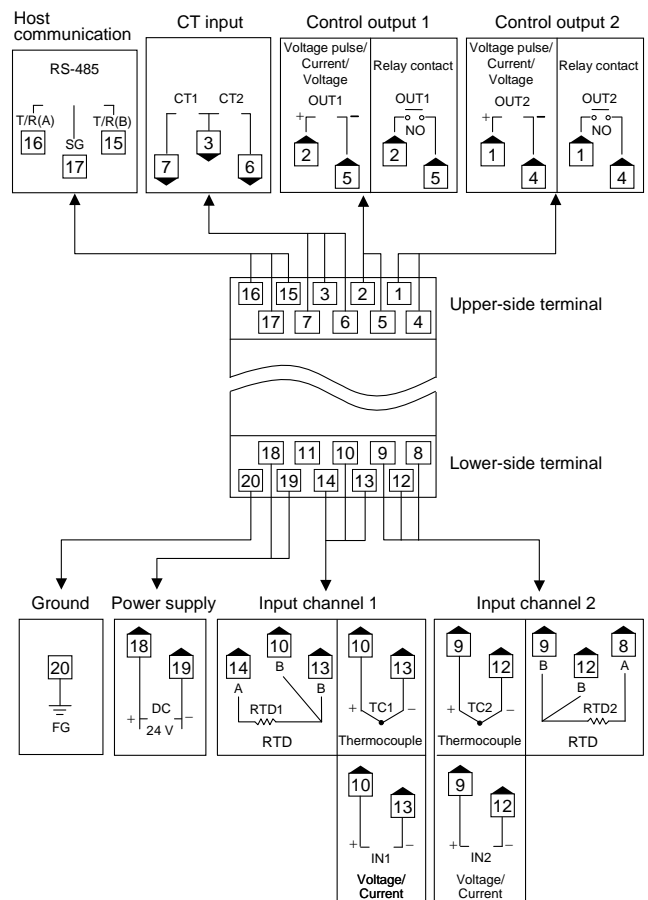

Heater break alarm (HBA) function cannot be used when control output is Voltage/Current output.



- Terminal No. 11 is not used.
- Input channel 2 can be used as remote setting input (only for Voltage/Current input). In this case, control output 2 and CT input 2 become unused.

7. SPECIFICATIONS

■ Inputs

Number of inputs:	2 points (Isolated between each channel)
Input type:	
• Thermocouple:	K, J, T, S, R, E, B, N (JIS-C1602-1995) PLII (NBS) W5Re/W26Re (ASTM-E988-96)
• RTD:	Pt100 (JIS-C1604-1997) JPt100 (JIS-C1604-1989, Pt100 of JIS-C1604-1981)
• Voltage (low):	0 to 10 mV DC, 0 to 100 mV DC, 0 to 1 V DC
• Voltage (high):	0 to 5 V DC, 0 to 10 V DC, 1 to 5 V DC
• Current:	0 to 20 mA DC, 4 to 20 mA DC (Input impedance: 250 Ω)
Sampling cycle:	25 ms
PV bias:	-Input span to +Input span
CT input:	2 points 0.0 to 30.0 A (CTL-6P-N) or 0.0 to 100.0 A (CTL-12-S56-10L-N)

■ Outputs

Number of outputs:	2 points (Isolated between input and output, and between output and power supply)
Output type:	
• Relay contact:	250 V AC, 3 A (Resistive load) 1a contact Electrical life 300,000 times or more (Rated load)
• Voltage pulse:	0/12 V DC (Load resistance 600 Ω or more)
• Current:	0 to 20 mA DC, 4 to 20 mA DC (Load resistance 600 Ω or less)
• Voltage:	0 to 5 V DC, 0 to 10 V DC, 1 to 5 V DC (Load resistance 1 k Ω or more)

■ Control action

Number of controls:	2 points
Control method:	Brilliant PID control Reverse action or direct action is selectable
Additional function:	Autotuning function Output limiter function Output change rate limiter function

■ Events

Number of events:	2 points/channel
Event type:	Temperature event: Deviation high, Deviation low, Deviation high/low, Band, Process high, Process low

■ Heater break alarm (HBA) function

Number of HBA:	2 points
Setting range:	0.0 to 100.0 A (0.0 A: OFF)
Additional function:	Number of event delay times: 1 to 255 times

■ Control loop break alarm (LBA) function

Number of LBA:	2 points
LBA time:	1 to 7200 seconds
LBA deadband (LBD) setting:	0 to Input span

■ Program control

Number of patterns:	16 pattern max. (With pattern link function)
Number of segments:	16 segment/pattern max.
Time signal output:	16 point/pattern

■ Communications

Communication interface:	Based on RS-485, EIA standard
Communication protocol:	RKC communication (ANSI X3.28-1976 subcategories 2.5 and A4) or Modbus

■ Others

Power supply voltage:	21.6 to 26.4 V DC (Including power supply voltage variation) Rating: 24 V DC
Current consumption:	120 mA or less/module
Allowable ambient temperature range:	-10 to +50 $^{\circ}$ C
Allowable ambient humidity range:	5 to 95 %RH (Non condensing) Absolute humidity: MAX.W.C 29 g/m ³ dry air at 101.3 kPa
Installation environment conditions:	Indoor use Altitude up to 2000 m
Weight:	Approx. 220 g

- Modbus is a registered trademark of Schneider Electric.
- Company names and product names used in this manual are the trademarks or registered trademarks of the respective companies.

The first edition: MAY 2002 [IMQ00]
The fifth edition: AUG. 2013 [IMQ00]