

Module Type Controller SRV

Temperature Control Module for PROFIBUS

V-TIO-G/V-TIO-H

Instruction Manual

IMS01P06-E4

Thank you for purchasing this RKC product. In order to achieve maximum performance and ensure proper operation of your new instrument, carefully read all the instructions in this manual. Please place the manual in a convenient location for easy reference.

SYMBOLS

WARNING : This mark indicates precautions that must be taken if there is danger of electric shock, fire, etc., which could result in loss of life or injury.

CAUTION : This mark indicates that if these precautions and operating procedures are not taken, damage to the instrument may result.



: This mark indicates that all precautions should be taken for safe usage.



: This mark indicates important information on installation, handling and operating procedures.



: This mark indicates supplemental information on installation, handling and operating procedures.



: This mark indicates where additional information may be located.



WARNING

- To prevent injury to persons, damage to instrument and equipment, a suitable external protection device shall be required.
- All wiring must be completed before power is turned on to prevent electric shock, fire or damage to instrument and equipment.
- This instrument must be used in accordance with the specifications to prevent fire or damage to instrument and equipment.
- This instrument is not intended for use in locations subject to flammable or explosive gases.
- Do not touch high-voltage connections such as power supply terminals, etc. to avoid electric shock.
- RKC is not responsible if this instrument is repaired, modified or disassembled by other than factory-approved personnel. Malfunction can occur and warranty is void under these conditions.

CAUTION

- This product is intended for use with industrial machines, test and measuring equipment. (It is not designed for use with medical equipment and nuclear energy.)
- This is a Class A instrument. In a domestic environment, this instrument may cause radio interference, in which case the user may be required to take additional measures.
- This instrument is protected from electric shock by reinforced insulation. Provide reinforced insulation between the wire for the input signal and the wires for instrument power supply, source of power and loads.

- Be sure to provide an appropriate surge control circuit respectively for the following:
 - If input/output or signal lines within the building are longer than 30 meters.
 - If input/output or signal lines leave the building, regardless the length.
- This instrument is designed for installation in an enclosed instrumentation panel. All high-voltage connections such as power supply terminals must be enclosed in the instrumentation panel to avoid electric shock by operating personnel.
- All precautions described in this manual should be taken to avoid damage to the instrument or equipment.
- All wiring must be in accordance with local codes and regulations.
- All wiring must be completed before power is turned on to prevent electric shock, instrument failure, or incorrect action. The power must be turned off before repairing work for input break and output failure including replacement of sensor, contactor or SSR, and all wiring must be completed before power is turned on again.
- To prevent instrument damage as a result of failure, protect the power line and the input/output lines from high currents with a suitable overcurrent protection device with adequate breaking capacity such as fuse, circuit breaker, etc.
- Prevent metal fragments or lead wire scraps from falling inside instrument case to avoid electric shock, fire or malfunction.
- Tighten each terminal screw to the specified torque found in the manual to avoid electric shock, fire or malfunction.
- For proper operation of this instrument, provide adequate ventilation for heat dispensation.
- Do not connect wires to unused terminals as this will interfere with proper operation of the instrument.
- Turn off the power supply before cleaning the instrument.
- Do not use a volatile solvent such as paint thinner to clean the instrument. Deformation or discoloration will occur. Use a soft, dry cloth to remove stains from the instrument.
- To avoid damage to instrument display, do not rub with an abrasive material or push front panel with a hard object.
- When high alarm with hold action/re-hold action is used for Event function, alarm does not turn on while hold action is in operation. Take measures to prevent overheating which may occur if the control device fails.

NOTICE

- This manual assumes that the reader has a fundamental knowledge of the principles of electricity, process control, computer technology and communications.
- The figures, diagrams and numeric values used in this manual are only for purpose of illustration.
- RKC is not responsible for any damage or injury that is caused as a result of using this instrument, instrument failure or indirect damage.
- RKC is not responsible for any damage and/or injury resulting from the use of instruments made by imitating this instrument.
- Periodic maintenance is required for safe and proper operation of this instrument. Some components have a limited service life, or characteristics that change over time.
- Every effort has been made to ensure accuracy of all information contained herein. RKC makes no warranty expressed or implied, with respect to the accuracy of the information. The information in this manual is subject to change without prior notice.
- No portion of this document may be reprinted, modified, copied, transmitted, digitized, stored, processed or retrieved through any mechanical, electronic, optical or other means without prior written approval from RKC.

1. OUTLINE

The V-TIO-G/V-TIO-H (temperature control module for PROFIBUS) can send/receive data to/from PROFIBUS compatible programmable controllers (PLC) via PROFIBUS.

[The features of V-TIO-G/V-TIO-H module]

- One module (V-TIO-G or V-TIO-H) enables temperature control corresponding to two channels.
- It has power supply and communication terminals in addition to temperature control input and output terminals.
- One digital input (DI) point and two digital output (DO) points can be optionally added.
- All data are set by communication.

☞ For PROFIBUS, refer to the **Module Type Controller SRV PROFIBUS Communication Instruction Manual (IMS01P07-E0)**.

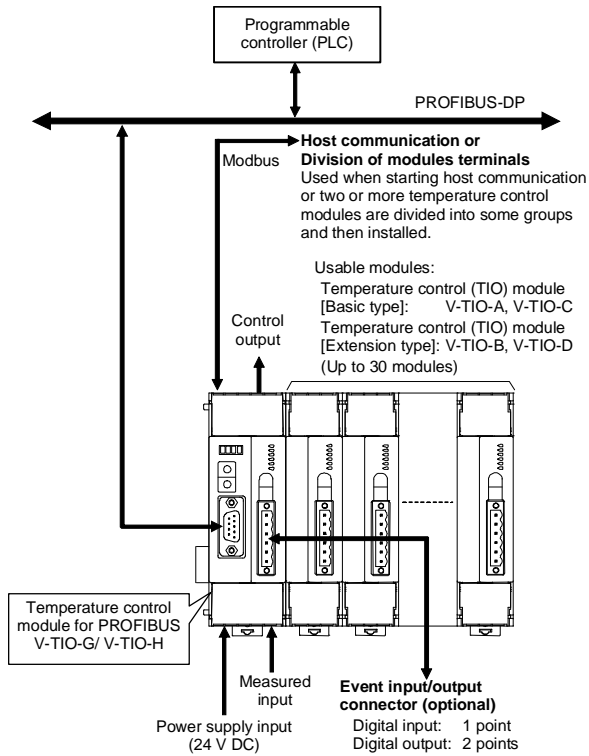

☞ For details when dividing two or more temperature control modules into some groups and then installed, refer to the **Module Type Controller SRV PROFIBUS Communication Instruction Manual (IMS01P07-E0)**.

☞ For communication using host communication terminals, refer to the **Module Type Controller SRV Communication Instruction Manual (IMS01P01-E0)**.

2. PRODUCT CHECK

Before using this product, check each of the following:

- Model code
- Check that all of the accessories delivered are complete.
- Check that there are no scratch or breakage in external appearance (case, front panel, terminal, etc).

V-TIO- □ □ □ □ □ - □ □ * □ □ □ - □ □ - □ / Y
 (1) (2) (3) (4) (5) (6) (7) (8) (9) (10) (11) (12)

(1) Type

- G: Module for PROFIBUS, Heat control
- H: Module for PROFIBUS, Heat/Cool control

(2) Control action

[For Heat control]

- F: PID action with autotuning (AT) (reverse action)
- D: PID action with autotuning (AT) (direct action)

[For Heat/Cool control]

B: Heat/Cool PID action with autotuning (AT) (air cooling)

W: Heat/Cool PID action with autotuning (AT) (water cooling)

(3) Input range (Each channel common code)

[Thermocouple input]

Type	Code	Range	Code	Range
K	K02	0 to 400 °C	KB9	32 to 752 °F
	K04	0 to 800 °C	KB8	32 to 1472 °F
	K16	-200 to +1372 °C	KB7	-328 to +2501 °F
	K09	0.0 to 400.0 °C	KC2	32.0 to 752.0 °F
	K35	-200.0 to +400.0 °C	KC1	-328.0 to +752.0 °F
J	J02	0 to 400 °C	JC2	32 to 752 °F
	J04	0 to 800 °C	JC1	32 to 1472 °F
	J15	-200 to +1200 °C	JB9	-328 to +2192 °F
	J09	0.0 to 400.0 °C	JC4	32.0 to 752.0 °F
	J27	-200.0 to +400.0 °C	JC3	-328.0 to +752.0 °F
T	T08	0 to 400 °C	TB9	32 to 752 °F
	T09	0 to 200 °C	TC1	32 to 392 °F
	T16	-200 to +400 °C	TB8	-328 to +752 °F
	T06	0.0 to 400.0 °C	TC3	32.0 to 752.0 °F
	T19	-200.0 to +400.0 °C	TC2	-328.0 to +752.0 °F
E	E01	0 to 800 °C	EA8	32 to 1472 °F
	E02	0 to 1000 °C	EA7	32 to 1832 °F
S	S05	0 to 1768 °C	SA6	32 to 3214 °F
R	R06	0 to 1768 °C	RA6	32 to 3214 °F
N	N02	0 to 1300 °C	NA6	32 to 2372 °F
B	B03	0 to 1800 °C	BB1	32 to 3272 °F
PL II	A02	0 to 1390 °C	AA6	32 to 2534 °F
W5Re/ W26Re	W03	0 to 2300 °C	WA9	32 to 4172 °F

[RTD input]

Type	Code	Range	Code	Range
Pt100	D17	0 to 400 °C	DC5	32 to 752 °F
	D33	0 to 850 °C	DC4	32 to 1562 °F
	D16	0.0 to 400.0 °C	DC7	32.0 to 752.0 °F
	D28	-200.0 to +400.0 °C	DC6	-328.0 to +752.0 °F
JPt100	P17	0 to 400 °C	PC5	32 to 752 °F
	P23	0 to 600 °C	PC4	32 to 1112 °F
	P16	0.0 to 400.0 °C	PC7	32.0 to 752.0 °F
	P28	-200.0 to +400.0 °C	PC6	-328.0 to +752.0 °F

[Voltage/Current input]

	Code	Type	Code	Type
Voltage	201	0 to 100 mV DC	401	0 to 5 V DC
	501	0 to 10 V DC	601	1 to 5 V DC
Current	701	0 to 20 mA DC	801	4 to 20 mA DC

(4) Control output (CH1), (5) Control output (CH2)

- M: Relay contact output
- V: Voltage pulse output 0/12 V DC
- 4: 0 to 5 V DC
- 5: 0 to 10 V DC
- 6: 1 to 5 V DC
- 7: 0 to 20 mA DC
- 8: 4 to 20 mA DC

(6) Event input (DI) [Optional]

- N: None
- 1: Control RUN/STOP
- 2: Event interlock release

(7) (8) Event output 1 (DO1) [Optional] *

(9) (10) Event output 2 (DO2) [Optional] *

[Code of (7)]

- N: None
- 1: Channel 1

[Code of (9)]

- N: None
- 2: Channel 2

[Code of (8) and (10)]

- N: None
- A: Deviation high
- B: Deviation low
- C: Deviation high/low
- D: Band
- E: Deviation high with hold action
- F: Deviation low with hold action
- G: Deviation high/low with hold action
- H: Process high
- J: Process low
- K: Process high with hold action
- L: Process low with hold action
- Q: Deviation high with re-hold action
- R: Deviation low with re-hold action
- T: Deviation high/low with re-hold action
- P: Heater break alarm (HBA)
- 1: Control loop break alarm (LBA)
- 2: Burnout
- 3: Temperature rise completion

* When "N" is selected in (7) or (9), (8) or (10) becomes "N."

(11) CT type (Each channel common code)

P: CTL-6-P-N S: CTL-12-S56-10L-N

(12) Version symbol

No code: For Japanese domestic market
/Y: For International market



- For Heat/Cool PID control (V-TIO-H), Input channel 2 becomes unused.
- For Heat/Cool PID control (V-TIO-H), Control output 1 corresponds to the heating output and Control output 2 corresponds to the cooling output.
- Heater break alarm (HBA) function cannot be used when control output is Voltage/Current output.
- Control loop break alarm (LBA) function cannot be used when control type is Heat/Cool PID control (V-TIO-H).

■ Accessories

End Plate	2
Joint connector cover.....	2
V-TIO-G/V-TIO-H Instruction Manual (IMS01P06-E4).....	1
GSD file (download free) *	1

* The GSD file can be downloaded from the official RKC website:
http://www.rkcinst.com/english/download/field_network.htm.



If any of the products are missing, damaged, or if your manual is incomplete, please contact RKC sales office or the agent.



The manuals can be downloaded from the official RKC website:
http://www.rkcinst.com/english/manual_load.htm.

3. PARTS DESCRIPTION

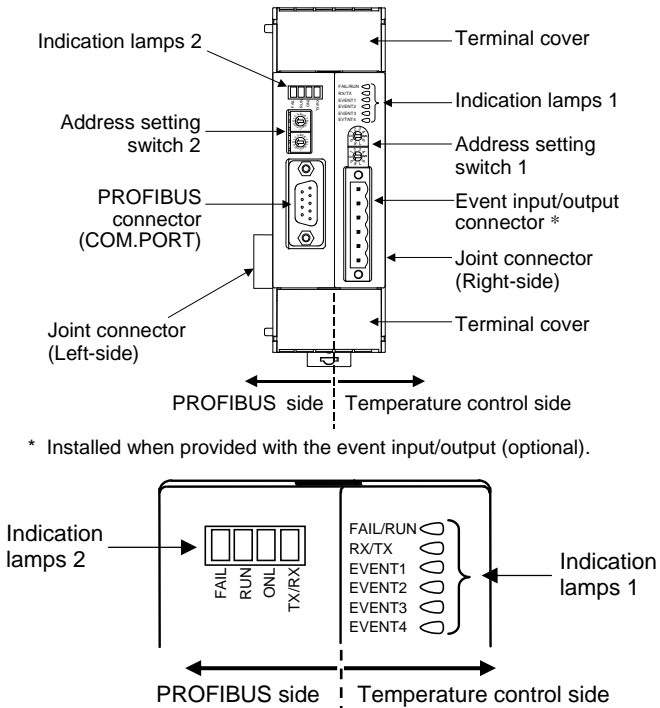

[Indication lamps 1]

- FAIL/RUN (for temperature control side)
When normally: A green lamp turns on (RUN)
When abnormally: A red lamp turns on (FAIL)
- RX/TX (for Modbus)
During data send and receive: A green lamp turns on
- EVENT 1 to 4
Display various states by setting.
During ON state: A green lamp turns on

Display contents

Event 1 state, Event 2 state, Comprehensive event state, Output state, and Control state

[Indication lamps 2]

- FAIL (for PROFIBUS side)
When hardware is normal: A red lamp turns off
When hardware is abnormal: A red lamp turns on
- RUN (for internal communication)
When normally: A green lamp turns on
When abnormally: A green lamp is flashing
- ONL
During PROFIBUS connection establishment:
A green lamp turns on
- RX/TX (for PROFIBUS communication)
During data send and receive: A green lamp turns on

4. COMMUNICATION SETTING

Set communication setting before mounting and wiring of SRV.

CAUTION

Do not separate the module mainframe from the terminal base with the power turned on. If separated, adjusted data may be destroyed; control be stopped, and no return can be made.

4.1 Address Setting

■ PROFIBUS address setting

Set an address of PROFIBUS. For this setting, use a small slotted screwdriver.

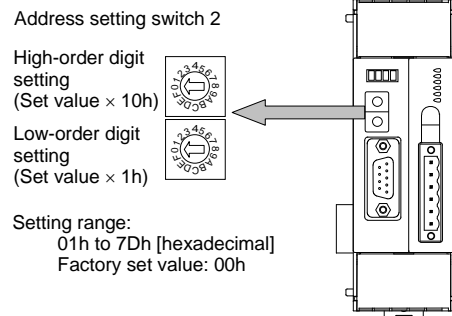

No communication with PROFIBUS can be conducted with each factory set value (00h) left as it is. Always set the PROFIBUS address.

■ Module address setting

Set an address of module. For this setting, use a small slotted screwdriver.

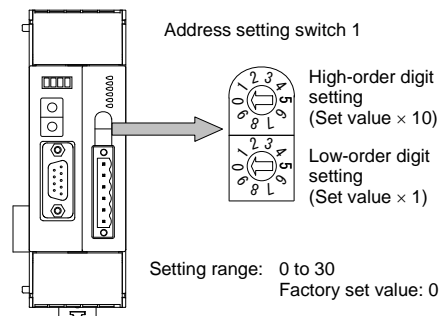

- When setting module address, always set their address from address number "0" in succession. Otherwise, problems or malfunction may result.
- For Modbus, the value obtained by adding "1" to the set address corresponds to the address used for the actual program.
- Set the module address such that it is different to the other addresses on the same line. Otherwise, problems or malfunction may result.

4.2 PROFIBUS/Host Communication Transfer Setting

With the dip switch 1 which there is on the left side of module, select PROFIBUS/Host communication transfer, and communication speed for internal communication in PROFIBUS.

 Internal communication is communication that V-TIO-G/V-TIO-H module conduct to other temperature control modules in PROFIBUS.

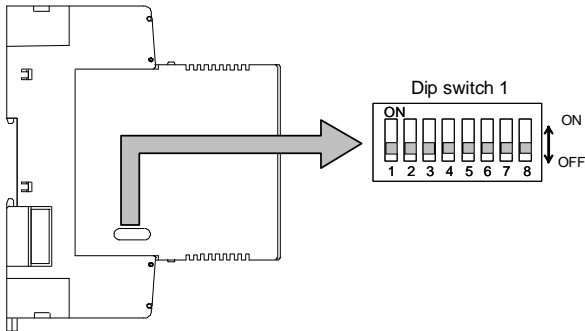

Left side view (PROFIBUS side)

1	2	Internal communication speed
OFF	OFF	38400 bps
ON	OFF	9600 bps
OFF	ON	19200 bps
ON	ON	38400 bps

Factory set value: 38400 bps

7	PROFIBUS/Host communication transfer
OFF	PROFIBUS (Internal communication validity)
ON	Host communication (Internal communication invalidity)

Factory set value: PROFIBUS (Internal communication validity)

 **Switch No. 3 to 6, 8: OFF fixed (Do not change the factory set values)**

[Factory set value]

- Internal communication speed: 38400 bps
- Internal communication protocol: Modbus

[Factory set value of the dip switch 1]

- | | |
|------------|------------|
| No. 1: OFF | No. 5: OFF |
| No. 2: OFF | No. 6: OFF |
| No. 3: OFF | No. 7: OFF |
| No. 4: OFF | No. 8: OFF |

 For host communication (Modbus), refer to the **Module Type Controller SRV Communication Instruction Manual (IMS01P01-EC)**.

4.3 Host Communication Setting

With the dip switch 2 which there is on the right side of module, select communication speed for host communication.

 **When host communication is not used, dip switch 2 need not be set.**

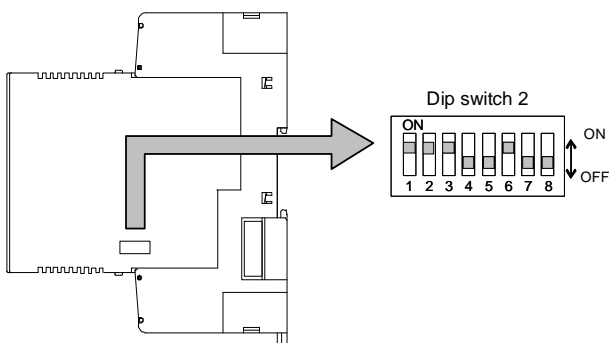

Right side view (temperature control side)

1	2	Host communication speed
OFF	OFF	2400 bps
ON	OFF	9600 bps
OFF	ON	19200 bps
ON	ON	38400 bps

Factory set value: 38400 bps

 **Switch No. 3 to 8: OFF fixed (Do not change the factory set values)**

[Factory set value]

- Host communication speed: 38400 bps
- Host communication protocol: Modbus

[Factory set value of the dip switch 2]

- | | |
|------------|------------|
| No. 1: ON | No. 5: OFF |
| No. 2: ON | No. 6: ON |
| No. 3: ON | No. 7: OFF |
| No. 4: OFF | No. 8: OFF |

 **When connecting two or more modules (V-TIO-A, V-TIO-B, V-TIO-C or V-TIO-D) to the module (V-TIO-G or V-TIO-H), match all of the switch No. 1, 2 settings with the internal settings of the module (V-TIO-G or V-TIO-H).**

5. MOUNTING



WARNING

To prevent electric shock or instrument failure, always turn off the power before mounting or removing the instrument.

5.1 Mounting Cautions

- (1) This instrument is intended to be used under the following environmental conditions. **(IEC61010-1)**
[OVERVOLTAGE CATEGORY II, POLLUTION DEGREE 2]
- (2) Use this instrument within the following environment conditions:
 - Allowable ambient temperature: -10 to +50 °C
 - Allowable ambient humidity: 5 to 95 %RH (Absolute humidity: MAX. W. C 29 g/m³ dry air at 101.3 kPa)
 - Installation environment conditions: Indoor use
Altitude up to 2000 m
- (3) Avoid the following when selecting the mounting location:
 - Rapid changes in ambient temperature, which may cause condensation.
 - Corrosive or inflammable gases.
 - Direct vibration or shock to the mainframe.
 - Water, oil, chemicals, vapor or steam splashes.
 - Excessive dust, salt or iron particles.
 - Excessive induction noise, static electricity, magnetic fields or noise.
 - Direct air flow from an air conditioner.
 - Exposure to direct sunlight.
 - Excessive heat accumulation.
- (4) Mount this instrument in the panel considering the following conditions:
 - Provide adequate ventilation space so that heat does not build up.
 - Do not mount this instrument directly above equipment that generates large amount of heat (heaters, transformers, semi-conductor functional devices, large-wattage resistors.)
 - If the ambient temperature rises above 50 °C, cool this instrument with a forced air fan, cooler, etc. Cooled air should not blow directly on this instrument.
 - In order to improve safety and the immunity to withstand noise, mount this instrument as far away as possible from high voltage equipment, power lines, and rotating machinery.
 - High voltage equipment: Do not mount within the same panel.
 - Power lines: Separate at least 200 mm.
 - Rotating machinery: Separate as far as possible.
 - Ensure at least 50 mm space on top and bottom of the control unit for maintenance and environmental reasons.
- (5) In case this instrument is connected to a supply by means of a permanent connection, a switch or circuit-breaker shall be included in the installation. This shall be in close proximity to the equipment and within easy reach of the operator. It shall be marked as the disconnecting device for the equipment.

5.2 Dimensions

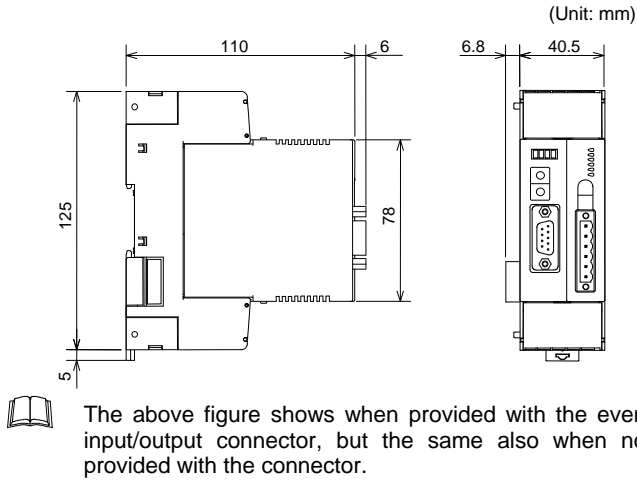

● Depth in connector mounting

Conduct installation in consideration of the sizes of the connector and cable when connector-connected.

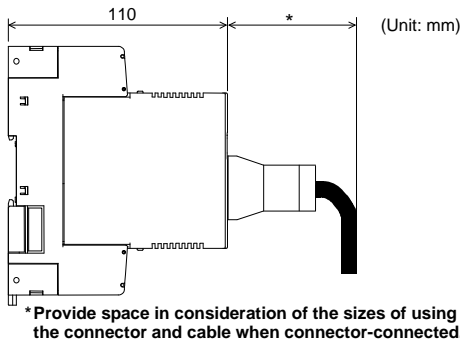

5.3 DIN rail Mounting

■ Mounting procedures

1. Pull down the mounting bracket at the bottom of the module (A). Attach the hooks on the top of the module to the DIN rail and push the lower section into place on the DIN rail (B).

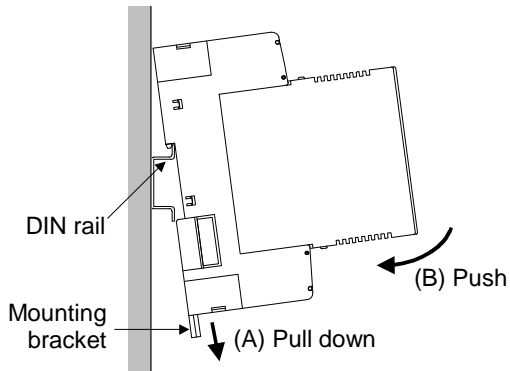

2. Slide the mounting bracket up to secure the module to the DIN rail.

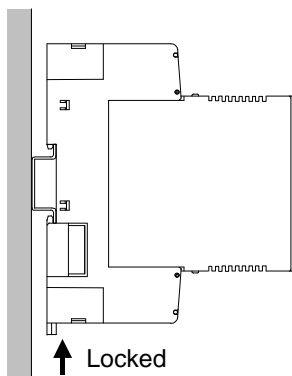

■ End Plate mounting

Hold tight both ends of the modules joined together with the end plates and then fix the end plates with screws. Even if only one module (V-TIO-G or V-TIO-H) is used, also hold tight both ends of the module with the end plates.

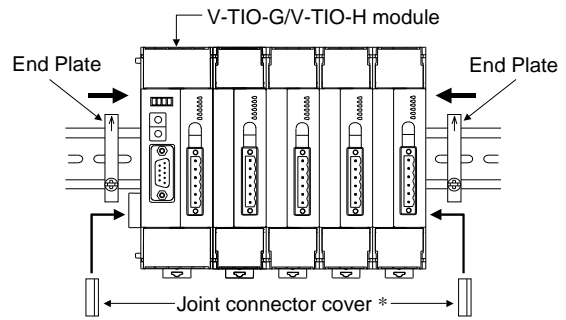

* For the conservation of the contact of connector, install a joint connector cover in module of both ends.

■ Removing procedures

Pull down a mounting bracket with a slotted screwdriver (A). Lift the module from bottom, and take it off (B).

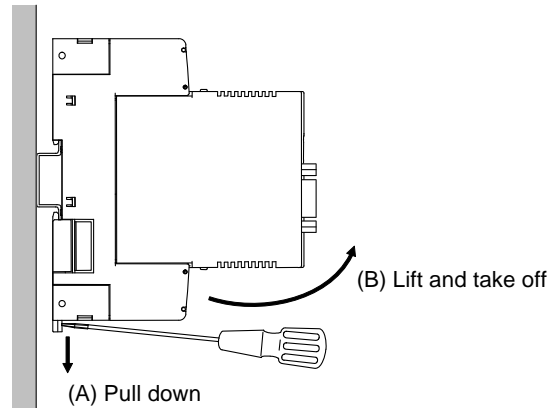

5.4 Panel Mounting

■ Mounting procedures

1. Pull down the mounting bracket (A) until locked and that a mounting hole appears.
2. Prepare one mounting bracket per module (B) sold separately (KSRX-55) and then insert it in the rear of the terminal board at top of the module until locked but a mounting hole does not disappear.
3. Mount each module directly on the panel with screws which are inserted in the mounting holes of the top and bottom mounting brackets.

Recommended tightening torque: 0.3 N·m (3 kgf·cm)

The customer needs to provide the M3 size screws. Select the screw length that matches the mounting panel.

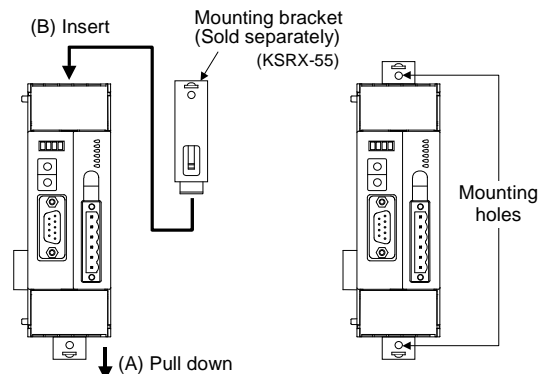

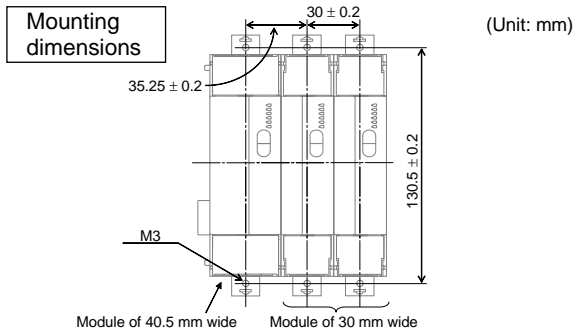

5.5 Jointing Each Module

Up to 30 modules (V-TIO-A, V-TIO-B, V-TIO-C or V-TIO-D) can be connected to one module (V-TIO-G or V-TIO-H). Joint these modules according to the following procedure.

■ Jointing procedure

1. Mount the modules on the DIN rail and then joint these modules together with the joint connector while sliding the relevant module.
2. Lift each of the joint tabs located at the top and bottom of the module and then insert it in the slot of the adjacent module to fix these two modules.

For panel mounting, first joint each module and then mount it on the panel.

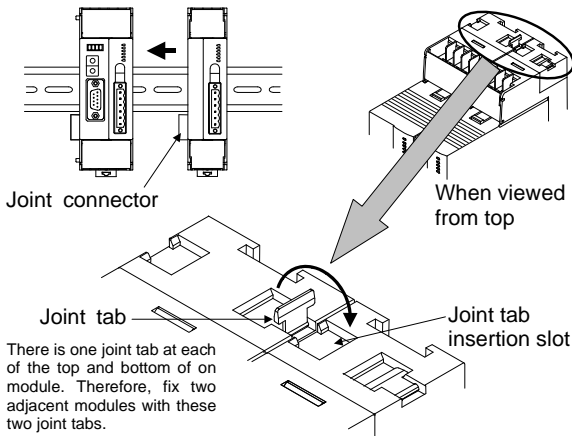

6. WIRING



To prevent electric shock or instrument failure, do not turn on the power until all wiring is completed. Make sure that the wiring is correct before applying power to the instrument.

6.1 Wiring Cautions

- For thermocouple input, use the appropriate compensation wire.
- For RTD input, use low resistance lead wire with no difference in resistance between the three lead wires.
- To avoid noise induction, keep input signal wire away from instrument power line, load lines and power lines of other electric equipment.
- Signal connected to Voltage input and Current input shall be low voltage defined as "SELV" circuit per IEC 60950-1.
- If there is electrical noise in the vicinity of the instrument that could affect operation, use a noise filter.
 - Shorten the distance between the twisted power supply wire pitches to achieve the most effective noise reduction.
 - Always install the noise filter on a grounded panel. Minimize the wiring distance between the noise filter output and the instrument power supply terminals to achieve the most effective noise reduction.

- Do not connect fuses or switches to the noise filter output wiring as this will reduce the effectiveness of the noise filter.

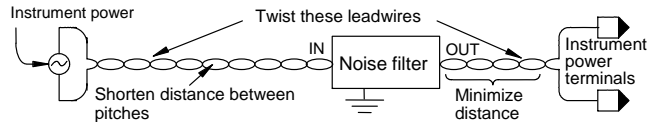

- Power supply wiring must be twisted and have a low voltage drop.
- For an instrument with 24 V power supply input, supply power from "SELV" circuit defined as IEC 60950-1.
- A suitable power supply should be considered in end-use equipment. The power supply must be in compliance with a limited-energy circuits (maximum available current of 8 A).
- In the maximum configuration (extension up to 31 modules) the 24 V DC supplied equipment may draw up to 4 A. The power supply shall be capable of delivering at least 4 A.
- Use the solderless terminal appropriate to the screw size.
 - Screw size: M3 x 6
 - Recommended tightening torque: 0.4 N·m [4 kgf·cm]
 - Specified solderless terminals: With isolation

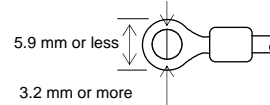

- Make sure that during field wiring parts of conductors can not come into contact with adjacent conductive parts.

6.2 Terminal Configuration

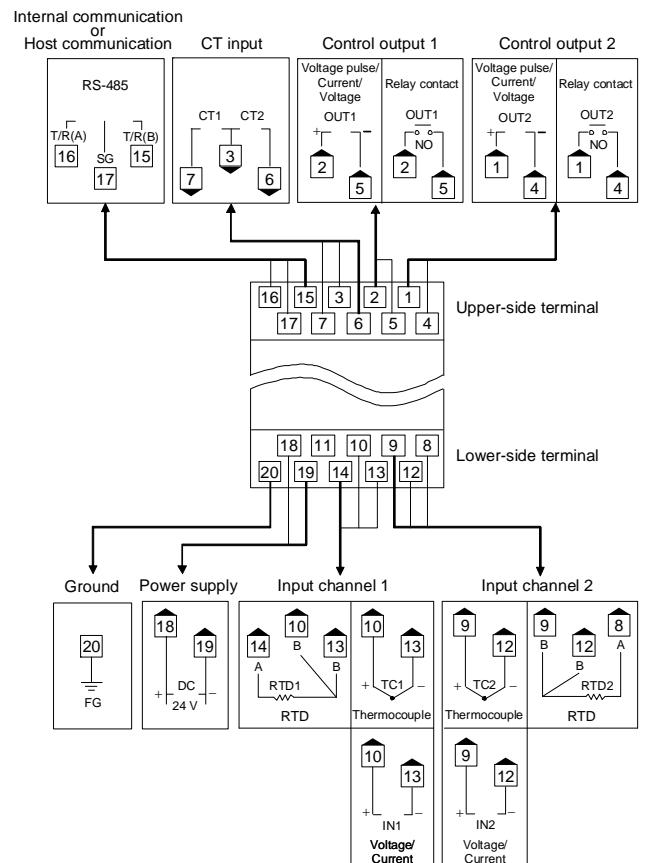

- For Heat/Cool PID control (V-TIO-H), Input channel 2 becomes unused.
- For Heat/Cool PID control (V-TIO-H), Control output 1 corresponds to the heating output and Control output 2 corresponds to the cooling output.
- Heater break alarm (HBA) function cannot be used when control output is Voltage/Current output.
- Control loop break alarm (LBA) function cannot be used when control type is Heat/Cool PID control (V-TIO-H).



Terminal No. 11 is not used.

6.3 Pin Layout of Connector

■ PROFIBUS connector

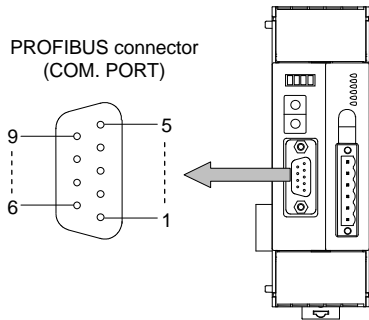

Pin No.	Signal name	Symbol
1	—	Unused
2	—	Unused
3	Receive data/Transmission data (plus)	RxD/TxD-P
4	—	Unused
5	Signal ground	DGND
6	Termination resistor supply voltage (5 V)	VP
7	—	Unused
8	Receive data/Transmission data (negative)	RxD/TxD-N
9	—	Unused

The PROFIBUS cable (a connection cable of PLC and SRV) is provided by customer. As for the PROFIBUS cable, there is a case prepared by a PLC manufacturer.

The details except the above are connected to a home page of PROFIBUS International, and obtain necessary information.
<http://www.profibus.com/>

■ Event connector

This is a connector installed in the V-TIO-G/V-TIO-H module only when provided with the event input (optional) or the event output (optional).

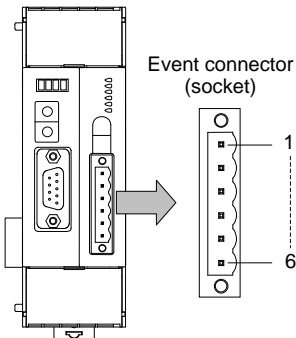

Pin No.	Description
1	Digital input (DI) (-)
2	Digital input (DI) (+)
3	Digital output (DO) 1 (Relay contact output)
4	Digital output (DO) 2 (Relay contact output)
5	Digital output (DO) 1 (Relay contact output)
6	Digital output (DO) 2 (Relay contact output)

● Circuit configuration

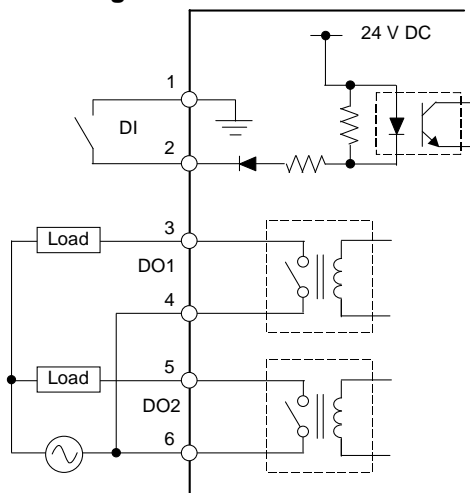

● Attention in connector (plug) wiring

- Use the following connector (plug) as that connected to the event input/output connector. Connector (plug) is sold separately.
 - SRVP-01 (Front-screw type)
 - SRVP-02 (Side-screw type)
- The lead wires use the stranded wire.
- Use the stranded wire from size 0.2 to 2.5 mm² (AWG 24-12).
- Stripping length is as follows.
 - SRVP-01: 10 mm
 - SRVP-02: 7 mm
- Recommended tightening torque of the lead wire in the connector (plug): 0.5 to 0.6 N·m (5 to 6 kgf·cm)

(Screw size: SRVP-01: M2.5
 SRVP-02: M3)

[SRVP-01] Front-screw type

[SRVP-02] Side-screw type

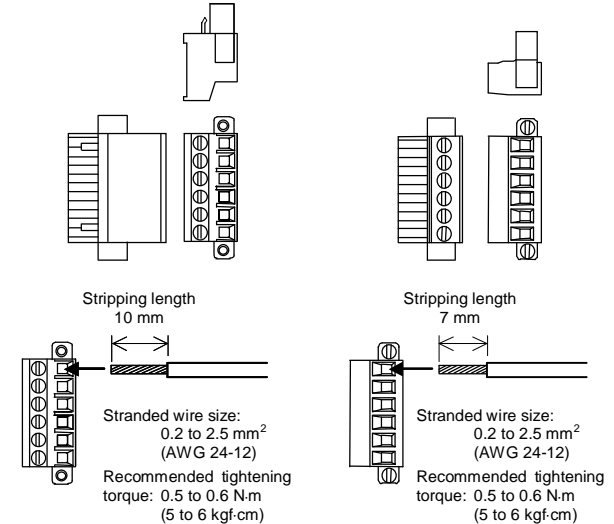

7. SPECIFICATIONS

■ Inputs

Number of inputs: 2 points
 Isolated between each channel:
 Thermocouple input, Voltage (low) input
 Not isolated between each channel:
 RTD input, Voltage (high) input, Current input

Input type:

- Thermocouple: K, J, T, S, R, E, B, N (JIS-C1602-1995) PLII (NBS) W5Re/W26Re (ASTM-E988-96)
- RTD: Pt100 (JIS-C1604-1997) JPt100 (JIS-C1604-1989, Pt100 of JIS-C1604-1981)
- Voltage (low): 0 to 100 mV DC
- Voltage (high): 0 to 5 V DC, 0 to 10 V DC, 1 to 5 V DC
- Current: 0 to 20 mA DC, 4 to 20 mA DC (Input impedance: 250 Ω)

Sampling cycle: 500 ms

PV bias: -Input span to +Input span

CT input: 2 points
 0.0 to 30.0 A (CTL-6P-N) or
 0.0 to 100.0 A (CTL-12-S56-10L-N)

■ Outputs

Number of outputs: 2 points
(Isolated between input and output, and between output and power supply)

Output type:

- Relay contact: 250 V AC, 3 A (Resistive load)
1a contact
Electrical life: 300,000 times or more
(Rated load)
- Voltage pulse: 0/12 V DC
(Load resistance 600 Ω or more)
- Current: 0 to 20 mA DC, 4 to 20 mA DC
(Load resistance 600 Ω or less)
- Voltage: 0 to 5 V DC, 0 to 10 V DC, 1 to 5 V DC
(Load resistance 1 kΩ or more)

■ Control action

Number of controls: 2 points
Control method: Brilliant PID control
Reverse action or direct action is selectable (Specify when ordering)
Heat/Cool control is selectable (Specify when ordering)

Additional function: Autotuning function

■ Events

Number of events: 2 points/channel
Event type: Temperature event:
Deviation high, Deviation low,
Deviation high/low, Band,
Process high, Process low
Heater break alarm (HBA),
Control loop break alarm (LBA),
Burnout, Temperature rise completion

■ Heater break alarm (HBA) function

Number of HBA: 2 points
Setting range: 0.0 to 100.0 A (0.0 A: OFF)
Additional function: Number of alarm delay times:
1 to 255 times

■ Control loop break alarm (LBA) function

Number of LBA: 2 points
LBA time: 1 to 7200 seconds
LBA deadband (LBD) setting:
0 to Input span

■ Optional

• Event input

Number of inputs: 1 point
Input type: Dry contact input
Input voltage: 24 V DC (Rated)
Input current: Approx. 6 mA
Input details: Control RUN/STOP,
Event interlock release
(Specify when ordering)

• Event output

Number of outputs: 2 points
Output type: Relay contact output
250 V AC, 1 A (Resistive load)
1a contact
Electrical life: 300,000 times or more
(Rated load)
Output details: Temperature event, Heater break alarm
(HBA), Control loop break alarm (LBA),
Burnout, Temperature rise completion
(Specify when ordering)

■ Communications

Communication interface:
Based on RS-485, EIA standard
Communication protocol:
PROFIBUS: PROFIBUS-DP
Internal communication: Modbus-RTU
Host communication: Modbus-RTU

■ Others

Power supply voltage: 21.6 to 26.4 V DC
(Including power supply voltage variation)
Rating: 24 V DC
Current consumption: With event input/output:
220 mA max./module
Without event input/output:
190 mA max./module
Allowable ambient temperature range:
-10 to +50 °C
Allowable ambient humidity range:
5 to 95 %RH (Non condensing)
Absolute humidity:
MAX.W.C 29 g/m³ dry air at 101.3 kPa
Weight: With event input/output:
Approx. 265 g
Without event input/output:
Approx. 255 g

■ Standard

Safety standard: UL: UL61010-1
cUL: CAN/CSA-C22.2 No.61010-1
CE marking: LVD: EN61010-1
OVERVOLTAGE CATEGORYII,
POLLUTION DEGREE 2,
Class II (Reinforced insulation)
EMC: EN61326-1
C-Tick: EN55011

• Modbus is a registered trademark of Schneider Electric.
• Company names and product names used in this manual are the trademarks or registered trademarks of the respective companies.

The first edition: FEB. 2004 [IMQ00]
The fourth edition: SEP. 2013 [IMQ00]