



SR Mini HG SYSTEM

*Power Supply/CPU Module
Link Module
[Control & Communication Link]*

***H-PCP-G
H-LNK-A***

Instruction Manual

- The MELSEC and **Control & Communication Link** system are products manufactured by Mitsubishi Electric Co., Ltd.
- Company names and product names used in this manual are the trademarks or registered trademarks of the respective companies.

Thank you for purchasing this RKC product. In order to achieve maximum performance and ensure proper operation of your new instrument, carefully read all the instructions in this manual. Please place the manual in a convenient location for easy reference.

SYMBOLS

WARNING : This mark indicates precautions that must be taken if there is danger of electric shock, fire, etc., which could result in loss of life or injury.

CAUTION : This mark indicates that if these precautions and operating procedures are not taken, damage to the instrument may result.



: This mark indicates that all precautions should be taken for safe usage.



: This mark indicates important information on installation, handling and operating procedures.



: This mark indicates supplemental information on installation, handling and operating procedures.



: This mark indicates where additional information may be located.



WARNING

- To prevent injury to persons, damage to instrument and equipment, a suitable external protection device shall be required.
- All wiring must be completed before power is turned on to prevent electric shock, fire or damage to instrument and equipment.
- This instrument must be used in accordance with the specifications to prevent fire or damage to instrument and equipment.
- This instrument is not intended for use in locations subject to flammable or explosive gases.
- Do not touch high-voltage connections such as power supply terminals, etc. to avoid electric shock.
- RKC is not responsible if this instrument is repaired, modified or disassembled by other than factory-approved personnel. Malfunction can occur and warranty is void under these conditions.

CAUTION

- This product is intended for use with industrial machines, test and measuring equipment. (It is not designed for use with medical equipment and nuclear energy.)
- This is a Class A instrument. In a domestic environment, this instrument may cause radio interference, in which case the user may be required to take additional measures.
- This instrument is protected from electric shock by reinforced insulation. Provide reinforced insulation between the wire for the input signal and the wires for instrument power supply, source of power and loads.
- Be sure to provide an appropriate surge control circuit respectively for the following:
 - If input/output or signal lines within the building are longer than 30 meters.
 - If input/output or signal lines leave the building, regardless the length.
- This instrument is designed for installation in an enclosed instrumentation panel. All high-voltage connections such as power supply terminals must be enclosed in the instrumentation panel to avoid electric shock by operating personnel.
- All precautions described in this manual should be taken to avoid damage to the instrument or equipment.
- All wiring must be in accordance with local codes and regulations.
- All wiring must be completed before power is turned on to prevent electric shock, instrument failure, or incorrect action.

The power must be turned off before repairing work for input break and output failure including replacement of sensor, contactor or SSR, and all wiring must be completed before power is turned on again.
- To prevent instrument damage as a result of failure, protect the power line and the input/output lines from high currents with a suitable overcurrent protection device with adequate breaking capacity such as fuse, circuit breaker, etc.
- Prevent metal fragments or lead wire scraps from falling inside instrument case to avoid electric shock, fire or malfunction.
- Tighten each terminal screw to the specified torque found in the manual to avoid electric shock, fire or malfunction.
- For proper operation of this instrument, provide adequate ventilation for heat dispensation.
- Do not connect wires to unused terminals as this will interfere with proper operation of the instrument.
- Turn off the power supply before cleaning the instrument.
- Do not use a volatile solvent such as paint thinner to clean the instrument. Deformation or discoloration will occur. Use a soft, dry cloth to remove stains from the instrument.
- To avoid damage to instrument display, do not rub with an abrasive material or push front panel with a hard object.
- Do not connect modular connectors to telephone line.
- When high alarm with hold action/re-hold action is used for Alarm function, alarm does not turn on while hold action is in operation. Take measures to prevent overheating which may occur if the control device fails.

NOTICE

- This manual assumes that the reader has a fundamental knowledge of the principles of electricity, process control, computer technology and communications.
- The figures, diagrams and numeric values used in this manual are only for purpose of illustration.
- RKC is not responsible for any damage or injury that is caused as a result of using this instrument, instrument failure or indirect damage.
- RKC is not responsible for any damage and/or injury resulting from the use of instruments made by imitating this instrument.
- Periodic maintenance is required for safe and proper operation of this instrument. Some components have a limited service life, or characteristics that change over time.
- Every effort has been made to ensure accuracy of all information contained herein. RKC makes no warranty expressed or implied, with respect to the accuracy of the information. The information in this manual is subject to change without prior notice.
- No portion of this document may be reprinted, modified, copied, transmitted, digitized, stored, processed or retrieved through any mechanical, electronic, optical or other means without prior written approval from RKC.

CONTENTS

	Page
1. OUTLINE.....	1
1.1 Product Outline.....	1
1.2 Handling Procedure.....	2
1.3 Checking the Products	3
1.4 Confirmation of the Model Code.....	4
1.5 System Configuration	5
1.6 Parts Description	7
1.6.1 H-PCP-G module	7
1.6.2 H-LNK-A module.....	8
2. SPECIFICATIONS	10
2.1 H-PCP-G Module.....	10
2.2 H-LNK-A Module	13
3. MOUNTING	15
3.1 Mounting Cautions.....	15
3.2 Dimensions.....	16
3.3 Mounting the Mother Block.....	18
3.4 Mounting the Module Mainframe	20
3.5 Removing the Module Mainframe.....	21
3.6 Terminal Covers	22
4. WIRING	23
4.1 Wiring of H-PCP-G Module.....	23
4.2 Connection of H-LNK-A Module With Master Station	26
5. PREPARATION BEFORE OPERATION	28
5.1 Station No. Setting.....	28
5.2 Transmission Speed Setting.....	29
5.3 Host Communication and Unit Address Settings.....	30

	Page
5.4 When the Power is Turned on for the First Time	31
5.5 Control Unit Operation When the PLC is Abnormal.....	31
6. REMOTE INPUT/OUTPUT AND REMOTE REGISTERS ..	32
6.1 Communication Between Master Station and Remote Device Station	32
6.2 Remote Input/Output	33
6.3 Remote Registers.....	43
6.4 Extension No.	45
6.5 Flag Operation.....	51
7. EXAMPLES OF SEQUENCE PROGRAMS	54
7.1 List of Internal Relays (M) and Data Registers (D)	55
7.2 Example of Initialize Sequence Program	60
7.3 Example of Data Fetch Sequence Program	61
7.4 Example of Set Data Change Sequence Program	62
8. HOST COMMUNICATION	63

1. OUTLINE

This manual should be used in conjunction with **Hardware Quick Manual (IMS01V01-E□)**.

1.1 Product Outline

The control unit for the SR Mini HG SYSTEM can easily configure a temperature control/monitoring system on **Control & Communication Link** by connecting it with **Control & Communication Link**. In addition, the control unit for the SR Mini HG SYSTEM correspond to **Control & Communication Link Ver. 1.10**.

 Control & Communication Link: Mitsubishi Electric field network

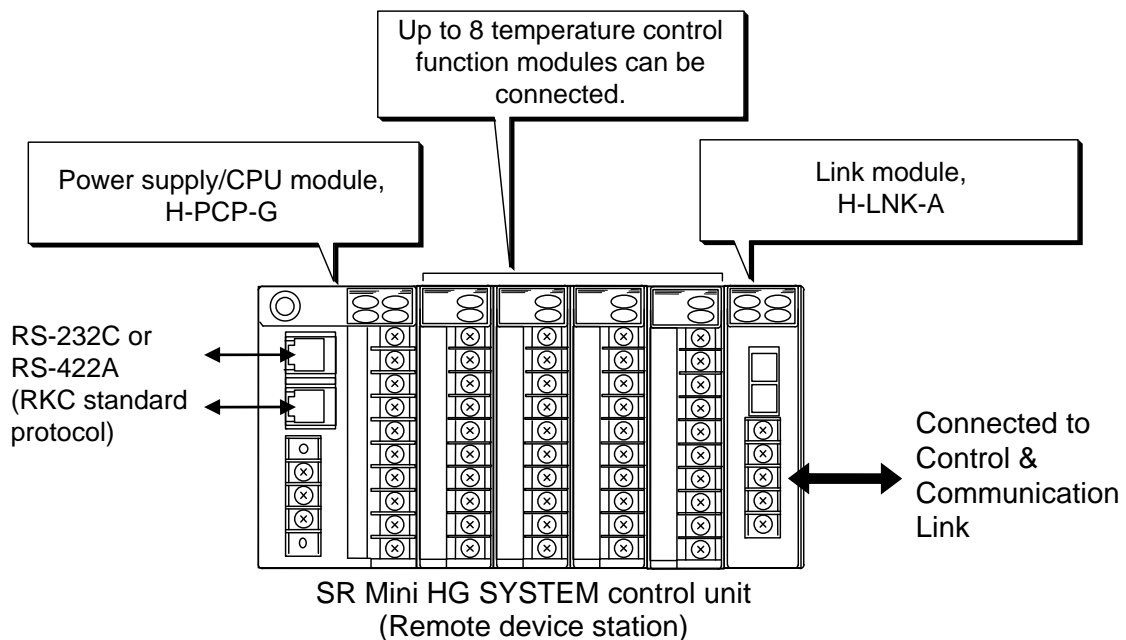

The control unit for the SR Mini HG SYSTEM consists of the dedicated power supply/CPU module (H-PCP-G), the Link module (H-LNK-A) and temperature control function modules.

This manual describes the specifications, mounting and wiring of the power supply/CPU module (H-PCP-G) and the Link module (H-LNK-A) and also data on the SR Mini HG SYSTEM processed by the **Control & Communication Link** system.

1.2 Handling Procedure

Proceed with the work according to the following procedure.

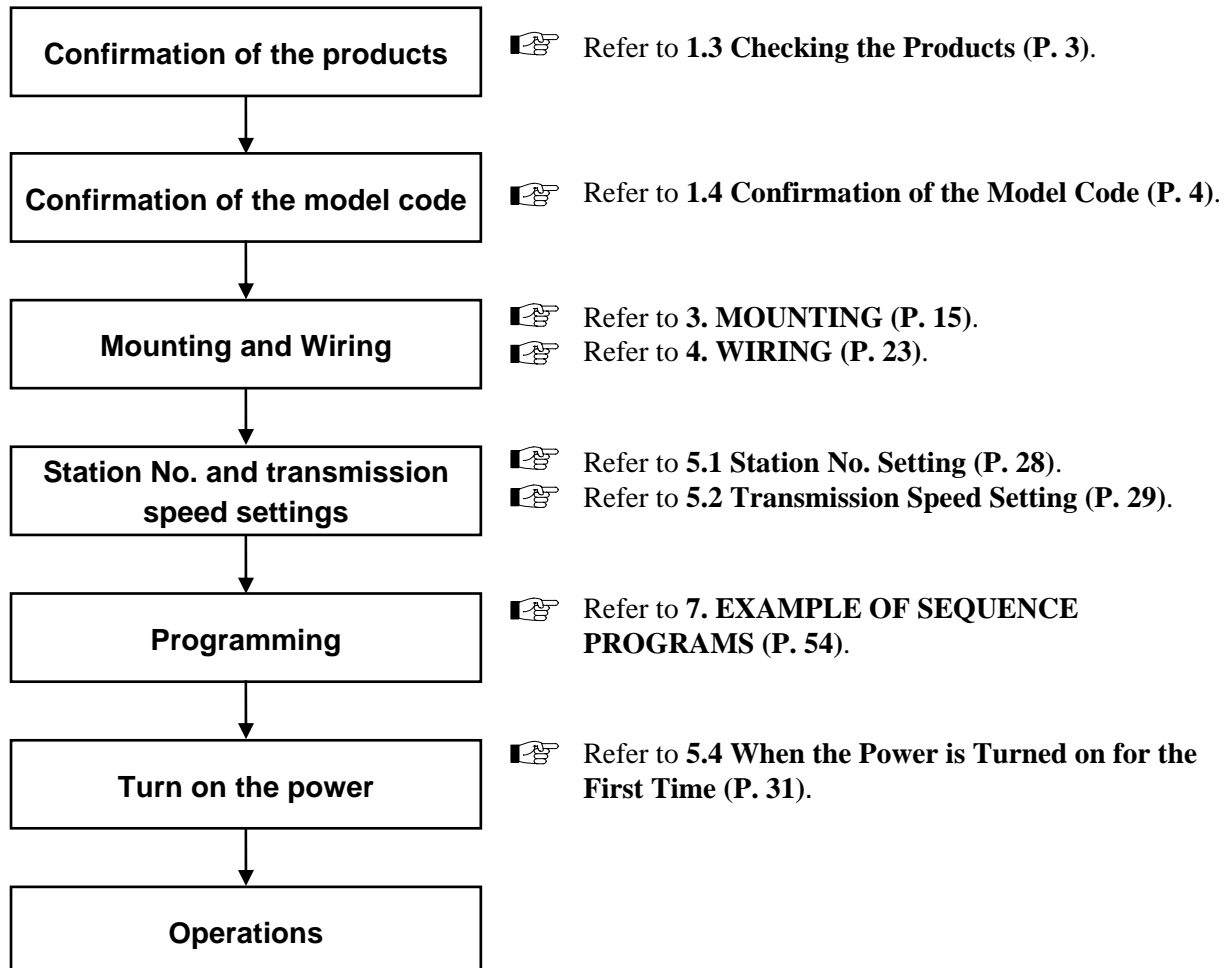

When conducting the mounting and wiring, station No. and transmission speed settings and programming, always read and follow the manual for Mitsubishi's PLC described in the following:

User's manual for Control & Communication Link system master/local unit,
Mitsubishi Electric Co., Ltd.

1.3 Checking the Products

When unpacking your new instrument, please confirm that the following products are included. If any of the products are missing, damaged, or if your manual is incomplete, please contact RKC sales office or agent for replacement.

H-PCP-G module (Power supply/CPU module)..... 1 module

One H-PCP-G module (power supply/CPU module) is required for each control unit.

H-LNK-A module (Link module) 1 module

One H-LNK-A module (Link module) is required for one control unit.

Function modules Required number of modules

Reference purchase order for description of function modules.

DIN rail holding clips..... Two clips per unit

Control & Communication Link

H-PCP-G/H-LNK-A Instruction Manual (IMSRM52-E6)..... 1 copy

Hardware Quick Manual (IMS01V01-E□)..... 1 copy

Communications Quick Manual (IMS01V02-E□) 1 copy

1.4 Confirmation of the Model Code

The model code for the instrument you received is listed below. Please confirm that you have received the correct instrument by checking the model code label, located on the left side of the module, with this list. If the product you received is not the one ordered, please contact RKC sales office or agent for replacement.



The Model code label is attached to the left side of the module.

■ H-PCP-G module (Power supply/CPU module)

H-PCP- G - 3 N - *
 (1) (2) (3) (4) (5) (6) (7)

(1) Type

G: Type dedicated to **Control & Communication Link** (DO: 4 points)

(2) Power supply voltage

3: 24 V DC

(3) Communication interface

1: RS-232C
 4: RS-422A

(4) External connector

N: No function

(5) DO signal

M: Relay contact output
 D: Open collector output

(6) First alarm function

N: No alarm function
: Refer to Alarm Code Table

(7) Second alarm function

N: No alarm function
: Refer to Alarm Code Table

Alarm Code Table

A: Deviation High	B: Deviation Low
C: Deviation High and Low	D: Deviation Band
E: Deviation High (with alarm hold)	F: Deviation Low (with alarm hold)
G: Deviation High and Low (with alarm hold)	H: Process High
J: Process Low	K: Process High (with alarm hold)
L: Process Low (with alarm hold)	
— A special alarm function —	
Q: Deviation High (with alarm re-hold)	R: Deviation Low (with alarm re-hold)
T: Deviation High and Low (with alarm re-hold)	



The selected function will be common for all the modules with alarm functions in the control unit.

■ H-LNK-A module (Link module)

H-LNK- A
 (1)

(1) Type

A: **Control & Communication Link** connection function type

1.5 System Configuration

If the SR Mini HG SYSTEM control unit is connected to **Control & Communication Link** via the H-LNK-A module (Link module), data on the SR Mini HG SYSTEM can be processed by the programmable controller (Mitsubishi MELSEC: hereinafter, PLC). In addition, the SR Mini HG SYSTEM control unit is connected to **Control & Communication Link** as a remote device station.

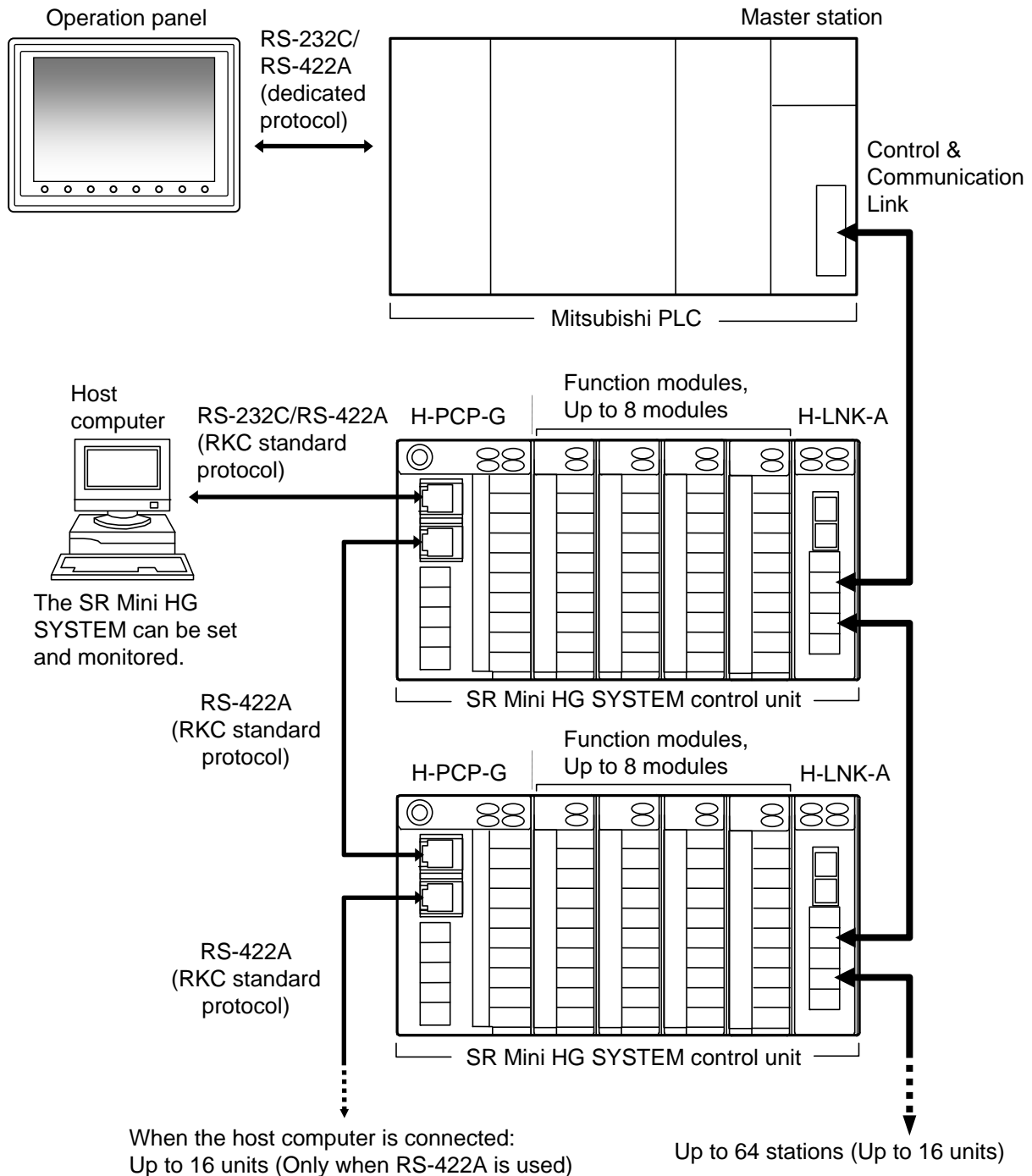

When only the SR Mini HG SYSTEM control units are connected to **Control & Communication Link**: Up to 16 units.

■ **Usable modules**

The following function modules can be used with **Control & Communication Link** in combination with the H-PCP-G and H-LNK-A modules.

Temperature control module

- H-TIO-A..... 1 channel type, Temperature input
- H-TIO-B..... 2 channels type, Temperature input
- H-TIO-C 1 channel heat/cool type, Temperature input
- H-TIO-D 2 channels heat/cool type, Temperature input
- H-TIO-E..... 1 channel type, High accuracy temperature input
- H-TIO-F..... 2 channels type, High accuracy temperature input
- H-TIO-G 1 channel heat/cool type, High accuracy temperature input
- H-TIO-H 1 channel type, Continuous voltage/current input
- H-TIO-J 2 channels type, Continuous voltage/current input
- H-TIO-R 1 channel type with fuzzy function, Temperature input
- H-TIO-P..... 2 channels type with fuzzy function, Temperature input



The current transformer (CT) input function built in the temperature control modules (H-TIO-A/C/D) cannot be used.

Current transformer input module

- H-CT-A..... CT input 6 points type (Each 2 points together are common)



For details of the temperature control modules and current transformer modules, refer to the separate **Hardware Quick Manual (IMS01V01-E□)**.

■ **Maximum No. of channels, modules or units when connected to Control & Communication Link**

Maximum number of control channels that can be connected to one control unit:

- 16 channels/control unit
- 256 channels/system (Only when the SR Mini HG SYSTEM is connected)

No. of function modules which can be connected to one control unit:

- 8 modules (excluding the H-PCP-G and H-LNK-A modules)/control unit



The maximum number of channels cannot be selected for the temperature control, temperature input or current transformer input modules as the number of function modules per control unit is limited to 10.

No. of control units which can be connected to Control & Communication Link:

- 16 units/system (Only when the SR Mini HG SYSTEM is connected)

1.6 Parts Description

1.6.1 H-PCP-G module

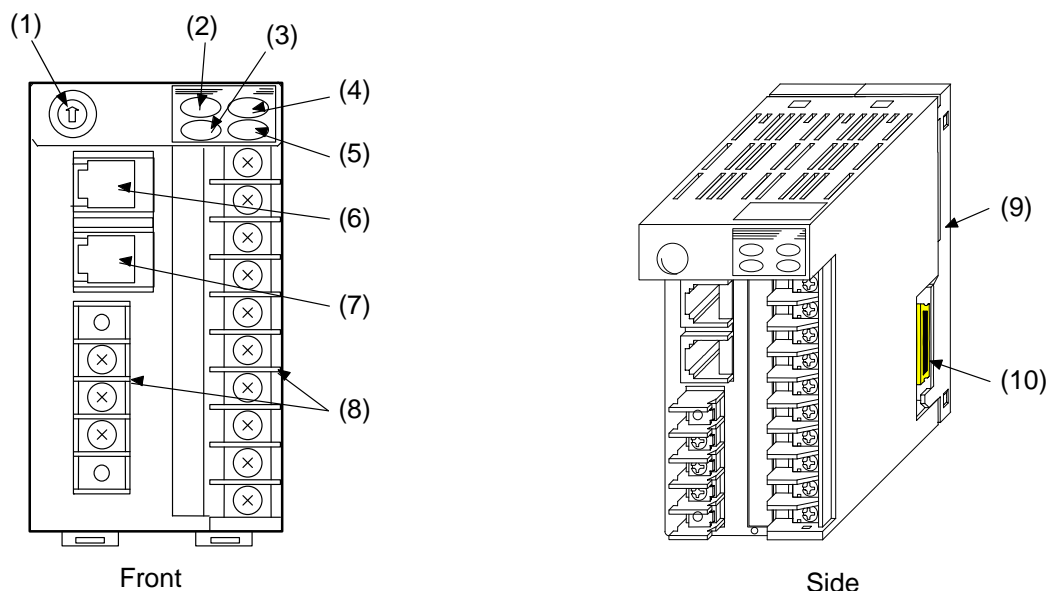

No.	Name	Description
(1)	Unit address No. setting switch	Switch to set control unite address No. Setting range: 0 to 15 (0 to F, hexadecimal)
(2)	Data correctly received indicator lamp (RX), Yellow LED	Turned on: During data receive
(3)	Data correctly sent indicator lamp (TX), Yellow LED	Turned on: During data send
(4)	Failure indicator lamp (FAIL), Red LED	Turned off: When the module is normal Turned on: When the module is abnormal
(5)	Operation indicator lamp (RUN), Green LED	Flashing: The module operates normally.
(6)	Modular connector 1	Connector for connection with the host computer Conforming to RS-232C or RS-422A
(7)	Modular connector 2	Extended link connector Conforming to RS-422A
(8)	Terminals	Power supply/ground/FAIL output/digital output terminals
(9)	Mother block	Module connection base block
(10)	Module connection connector	Power supply and internal bus connection connector

1.6.2 H-LNK-A module

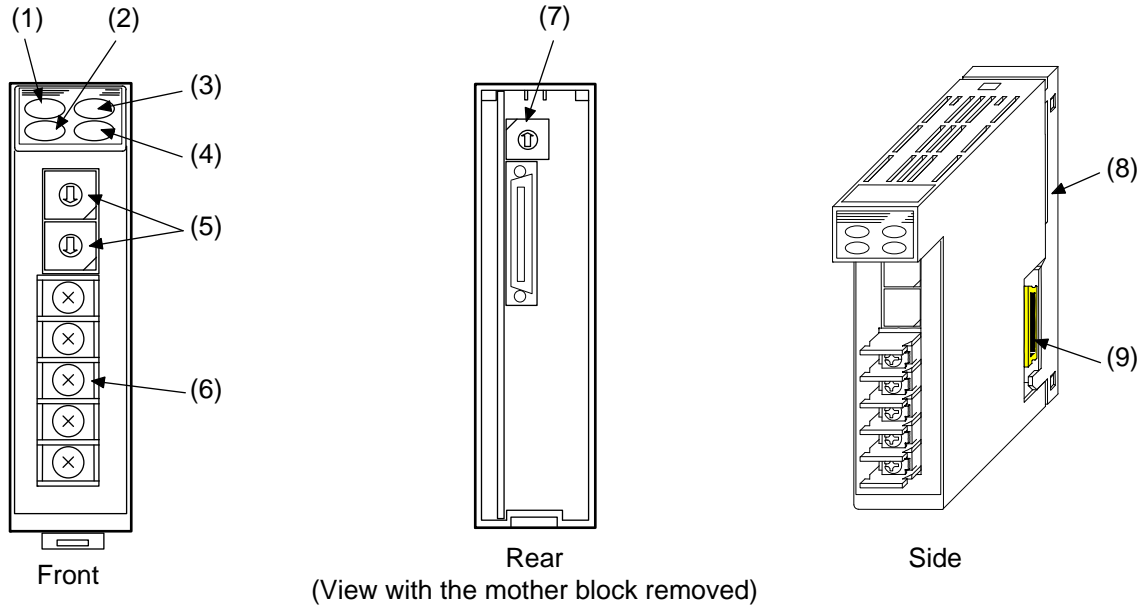

No.	Name	Description
(1)	Data correctly received indicator lamp (RX), Yellow LED	Turned on: During data receive
(2)	Data correctly sent indicator lamp (TX), Yellow LED	Turned on: During data send
(3)	Failure indicator lamp (FAIL), Red LED	Turned off: When the module is normal Turned on: When the module is abnormal Flashing 2: Transmission speed setting or station setting error now occurs. At intervals of 0.5 sec (OFF for 0.25 sec/ON for 0.25 sec)
(4)	Operation indicator lamp (RUN), Green LED	Turned on: H-LNK-A module is not identified by H-PCP-G module or H-LNK-A module is being initialized. Flashing 1: The module operates normally. At intervals of 1 sec (OFF for 0.5 sec/ON for 0.5 sec) Flashing 2: – The transmission speed setting or station No. setting switch was changed during operation. – CRC error now occurs. At intervals of 0.5 sec (OFF for 0.25 sec/ON for 0.25 sec)

Continued on the next page.

Continued from the previous page.

No.	Name	Description
(5)	Station No. setting switch (STATION No.) × 10: For tens digit setting × 1: For unit digit setting	Switch to set control unit station No. Setting range: 1 to 61
(6)	Communication terminals	Control & Communication Link connection terminals
(7)	Transmission speed setting switch	Switch to set the transmission speed of the control unit and Control & Communication Link master station Setting range: 0 to 4 0: 156 Kbps 1: 625 Kbps 2: 2.5 Mbps 3: 5 Mbps 4: 10 Mbps 5 to 9: Setting inhibited
(8)	Mother block	Module connection base block
(9)	Module connection connector	Power supply and internal bus connection connector

(4) Output

Item	Specifications
FAIL output	<p>Relay contact output Number of output points: 1 point Rating: 250 V AC, 0.1 A (Resistive load) CE/UL/cUL (or CSA) approved instrument: 30 V DC, 0.1 A Electrical life: 300,000 time or more (Rated load) Contact type: 1a contact Failure action: Open at error occurrence</p>
Digital output	<p>Relay contact output Number of output points: 4 points Rating: 250 V AC, 0.1 A (Resistive load) CE/UL/cUL (or CSA) approved instrument: 30 V DC, 0.1 A Electrical life: 300,000 time or more (Rated load) Contact type: 1a contact</p> <p>Open collector output Number of output points: 4 points Rating: 12 to 24 V DC Maximum load current: 0.1 A/point, 0.8 A/common Specify either relay contact output or open-collector output when ordering. Digital output can be selected from among the following outputs.</p> <ul style="list-style-type: none"> - Temperature alarm (First alarm, Second alarm) - Heater break alarm (HBA) - Burnout alarm - Loop break alarm (LBA) - Temp. rise completion

(5) Interface (RKC standard communication)

Item	Specifications
Communication interface	Based on RS-422A, EIA standard Based on RS-232C, EIA standard Specify when ordering
Communication method	4-wire system, multi-drop connection (RS-422A) Point-to-point connection (RS-232C)
Protocol	Based on ANSI X 3.28 subcategory 2.5, B1
Synchronous method	Start-stop synchronous type
Communication speed	2400 bps, 4800 bps, 9600 bps, 19200 bps Any can be selected.
Data bit configuration	Start bit: 1 Data bit: 7 or 8 Parity bit: Without, Odd or Even (For 8 data bits: Without) Stop bit: 1
Error control	Vertical parity (When parity bit is selected) Horizontal parity
Data types	ASCII code

(6) System setting items

Item	Specifications
Temperature alarm	First alarm and Second alarm <ul style="list-style-type: none"> - Deviation high alarm - Deviation low alarm - Deviation high/low alarm - Band alarm - Deviation high alarm with hold action - Deviation low alarm with hold action - Deviation high/low alarm with hold action - Process high alarm - Process low alarm - Process high alarm with hold action - Process low alarm with hold action - Deviation high alarm with re-hold action - Deviation low alarm with re-hold action - Deviation high/low alarm with re-hold action Specify either the 1st alarm or 2nd alarm function when ordering. The specified function is common to all of the modules with the alarm function within the control unit.
Temperature rise completion function	Completion trigger range: ± 1 to ± 10 °C (20 °F) (Value from main set value) Temperature rise completion soak time: 0 to 360 minutes Temperature rise completion trigger function can be selected for each channel.

(7) LED display

Item	Specifications
RUN lamp	Green LED Flashing: The module operates normally.
FAIL lamp	Red LED Turned off: When the module is normal Turned on: When the module is abnormal
TX lamp	Yellow LED Turned on: During data send
RX lamp	Yellow LED Turned on: During data receive

(8) General specifications

Item	Specifications
Dimensions	48 (W) × 96 (H) × 100 (D) mm
Weight	320 g

2.2 H-LNK-A Module

Item	Specifications	
Module type	Remote device station	
No. of occupied stations	4 stations occupied	
Transmission speed	0: 156 Kbps 1: 625 Kbps 2: 2.5 Mbps 3: 5 Mbps 4: 10 Mbps Set by the rotary switch at the rear of the module. The maximum transmission distance differs depending on the transmission speed.	
Maximum transmission distance	156 Kbps: 1200 m 625 Kbps: 900 m 2.5 Mbps: 400 m 5 Mbps: 160 m 10 Mbps: 100 m	
Distance between stations	0.2 m or more	
Station No. setting	1 to 61 (Setting other than this setting causes error.) Set by the rotary switch at the front of the module.	
LED display	RUN lamp	Green LED Turned on: H-LNK-A module is not identified by H-PCP-G module or H-LNK-A module is being initialized. Flashing 1: The module operates normally. At intervals of 1 sec (OFF for 0.5 sec/ON for 0.5 sec) Flashing 2: – The transmission speed setting or station No. setting switch was changed during operation. – CRC error now occurs. At intervals of 0.5 sec (OFF for 0.25 sec/ON for 0.25 sec)
LED display	FAIL lamp	Red LED Turned off: When the module is normal Turned on: When the module is abnormal Flashing 2: Transmission speed setting or station setting error now occurs. At intervals of 0.5 sec (OFF for 0.25 sec/ON for 0.25 sec)
	TX lamp	Yellow LED Turned on: During data send
	RX lamp	Yellow LED Turned on: During data receive

Continued on the next page.

Continued from the previous page.

Item	Specifications
Communication items	<p>Remote relay</p> <ul style="list-style-type: none"> - First alarm status - Second alarm status - Burnout alarm status - Heater break alarm (HBA) status - PID/AT transfer status - Control RUN/STOP transfer <hr/> <p>Remote registers (Read only)</p> <ul style="list-style-type: none"> - Temperature measured value (PV) - Manipulated output (Heat-side) - Manipulated output (Cool-side) - CT input measured value - Control RUN/STOP status - Decimal-point position - Set value monitoring - Control loop break alarm (LBA) status - Error code <hr/> <p>Remote registers (Common to read and write)</p> <ul style="list-style-type: none"> - Temperature set value (SV) - PID/AT transfer - Proportional band (Heat-side) - Proportional band (Cool-side) - Integral Time - Derivative Time - Control response designation parameters - PV bias - First alarm set value - Second alarm set value - Proportioning cycle time (Heat-side) - Proportioning cycle time (Cool-side) - Overlap/Deadband - Heater break alarm (HBA) set value - Operation mode setting - Memory area number - Auto/Manual transfer - Manual output value - Loop break alarm (LBA) use selection - LBA time setting - LBA Deadband
No. of remote register channels	0: 16 channels 1: 8 channels Factory set value: 0 Can be changed by the host computer communication setting.
Current consumption	290 mA DC
Dimensions	24 (W) × 96 (H) × 100 (D) mm
Weight	200 g

3. MOUNTING

This Chapter describes the mounting procedures for the H-PCP-G and H-LNK-A modules. For details of the mounting procedures for other modules and the mounting position of the control unit, refer to the **Hardware Quick manual (IMS01V01-E□)**.



WARNING

To prevent electric shock or instrument failure, always turn off the power before mounting or removing the instrument.



Mount the H-PCP-G module on the left side of the control unit.



In order to facilitate the wiring and connection of the H-LNK-A module, the module should be mounted on the right side of the control unit.

3.1 Mounting Cautions

- (1) This instrument is intended to be used under the following environmental conditions. (IEC 61010-1) [OVERVOLTAGE CATEGORY II, POLLUTION DEGREE 2]
- (2) Use this instrument within the following environment conditions:
 - Allowable Ambient temperature: 0 to 50 °C
 - Allowable Ambient humidity: 45 to 85 %RH
(Absolute humidity: MAX.W.C 29g/m³ dry air at 101.3 kPa)
 - Installation environment conditions: Indoor use
Altitude up to 2000 m
- (3) Avoid the following conditions when selecting the mounting location:
 - Rapid changes in ambient temperature which may cause condensation.
 - Corrosive or inflammable gases.
 - Direct vibration or shock to the mainframe.
 - Water, oil, chemicals, vapor or steam splashes.
 - Excessive dust, salt or iron particles.
 - Excessive induction noise, static electricity, magnetic fields or noise.
 - Direct air flow from an air conditioner.
 - Exposure to direct sunlight.
 - Excessive heat accumulation.
- (4) Mount this instrument in the panel considering the following conditions:
 - Provide adequate ventilation space so that heat does not build up.
 - Do not mount this instrument directly above equipment that generates large amount of heat (heaters, transformers, semi-conductor functional devices, large-wattage resistors.)
 - If the ambient temperature rises above 50 °C, cool this instrument with a forced air fan, cooler, etc. Cooled air should not blow directly on this instrument.
 - In order to improve safety and the immunity to withstand noise, mount this instrument as far away as possible from high voltage equipment, power lines, and rotating machinery.
 - High voltage equipment: Do not mount within the same panel.
 - Power lines: Separate at least 200 mm.
 - Rotating machinery: Separate as far as possible.
- (5) In case this instrument is connected to a supply by means of a permanent connection, a switch or circuit-breaker shall be included in the installation. This shall be in close proximity to the equipment and within easy reach of the operator. It shall be marked as the disconnecting device for the equipment.

3.2 Dimensions

External Dimensions

(Unit: mm)

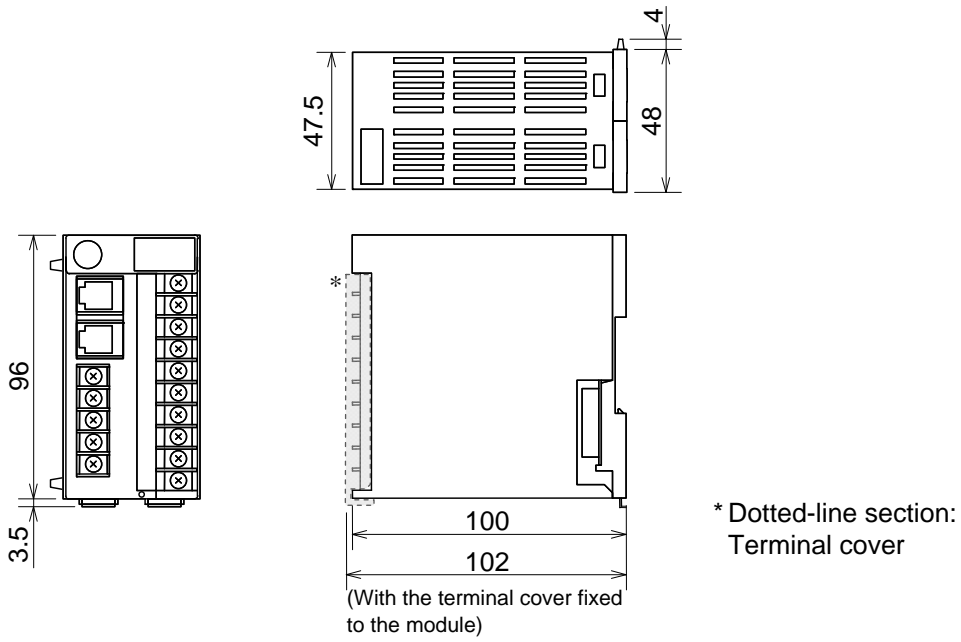

H-PCP-G module

(Unit: mm)

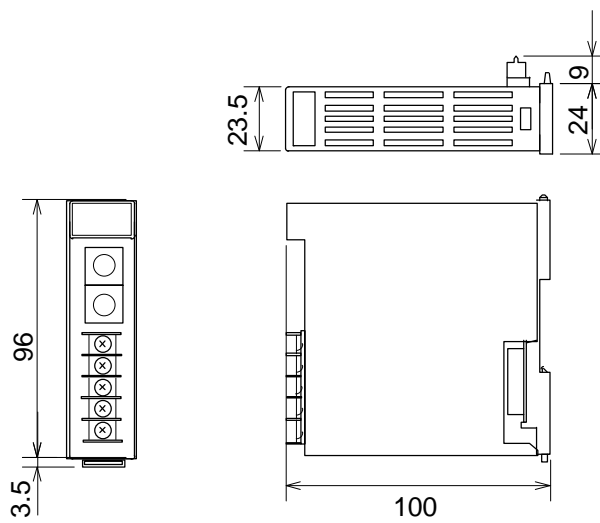

H-LNK-A module

■ Module mounting depth (For DIN rail mounting)

The mounting depth of each module is 108 mm from the mounting surface inside the panel to the front of the module with the module mounted on the DIN rail. However, when modular connector cables are plugged in, additional depth is required.

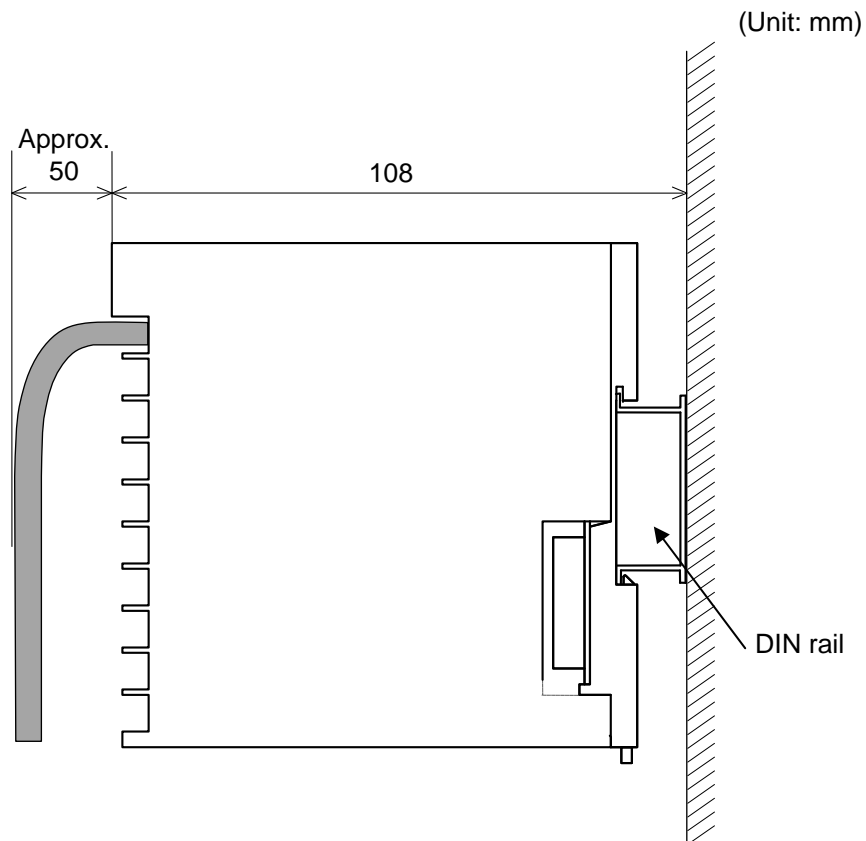

3.3 Mounting the Mother Block

The mother block can be mounted to a panel or on the DIN rail.

 **Mount the H-PCP module on the left side of the control unit.**

■ Panel mounting directions

1. Refer to both the panel mounting dimensions below and the **3.2 Dimensions (P. 16)** when selecting the location.

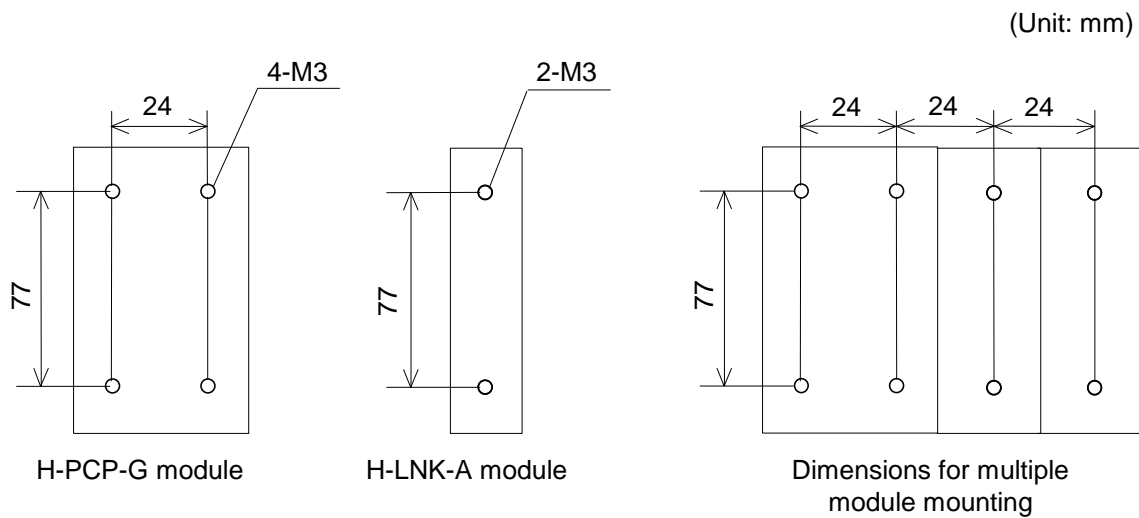

2. Remove the module from the mother block. For details of removing the module, Refer to **3.5 Removing the Module Mainframe (P. 21)**.
3. Connect the mother blocks together before tightening the screws on the panel.
(Customer must provide the set screws)

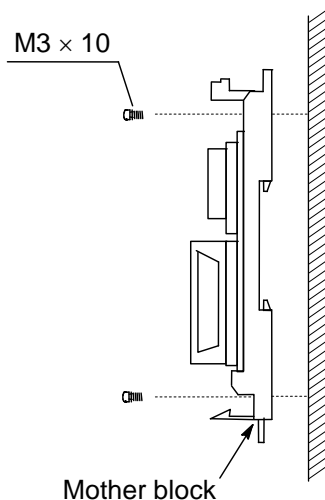

Tightening torque
Recommended value: 0.3 N·m (3 kgf·cm)

 **When the mother block is mounted on the panel, 50 mm or more space is required at the top and bottom of the mother block to attach the module mainframe.**

■ Mounting on the DIN rail

1. Remove the module mainframe from the mother block. For details of removing the module mainframe, Refer to **3.5 Removing the Module Mainframe (P. 21)**.
2. Pull down the locking device at the bottom of the mother block. (Figure 1)
For the H-PCP-G module, as there are two locking devices, pull down both of them.
3. Attach the top bracket of the mother block to the DIN rail and push the lower section into place on the DIN rail. (Figure 2)
4. Slide the locking devices up to secure the mother block to the DIN rail. (Figure 3)
5. Slide connectors together to complete mother block installation. (Figure 4)

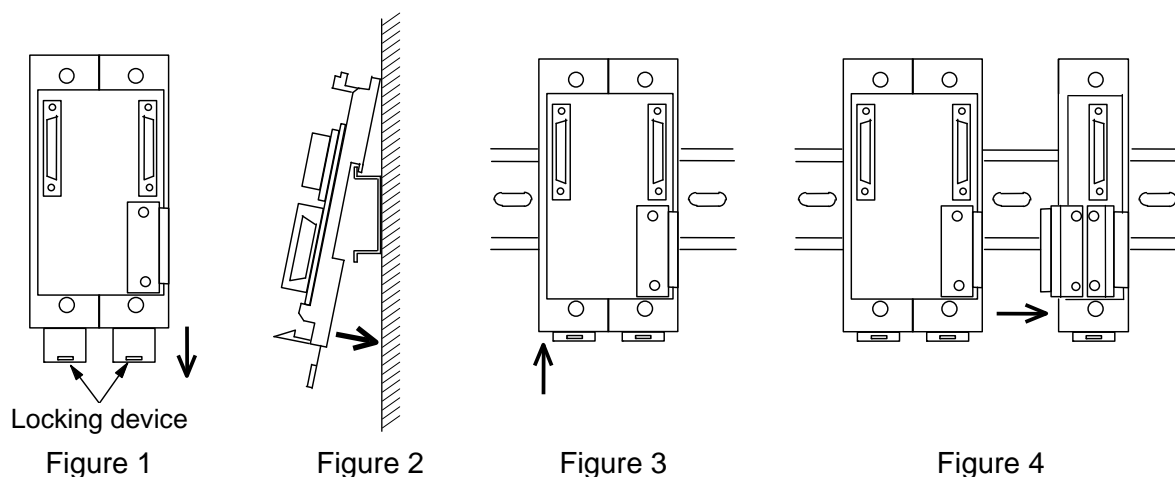

When the mother block is mounted on the panel, 50 mm or more space is required at the top and bottom of the mother block to attach the module mainframe.

3.4 Mounting the Module Mainframe

It engages the module with the mother block that is mounted on DIN rail or a panel.

1. Place the module mainframe opening on top of the mother block tab.
(Figure 1, 3)

2. Snap the lower part of module mainframe on to the mother block. (Figure 2, 4)
A snapping sound will be heard when module mainframe is securely connected to mother block.

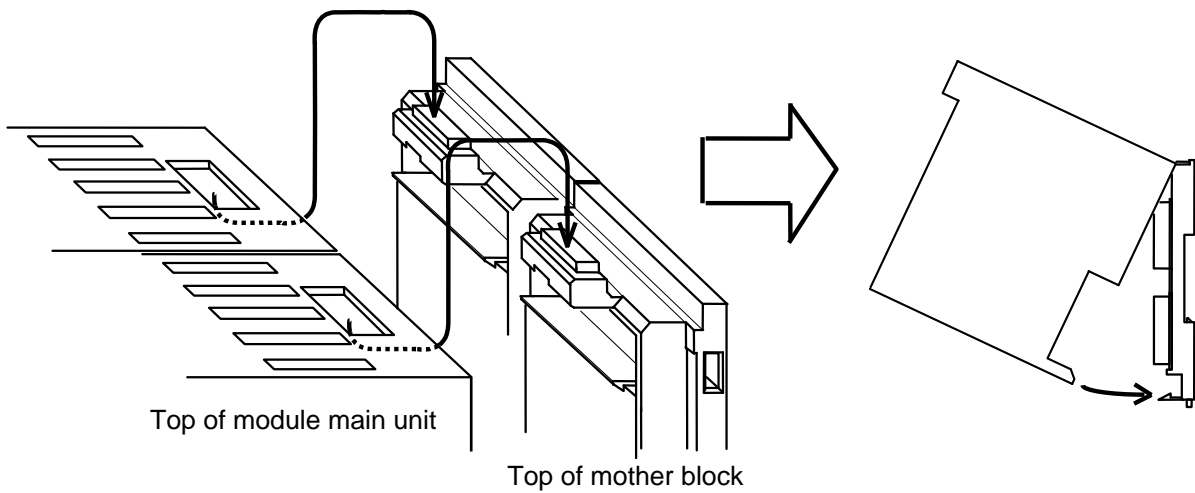

Figure 1

Figure 2

H-PCP-G module

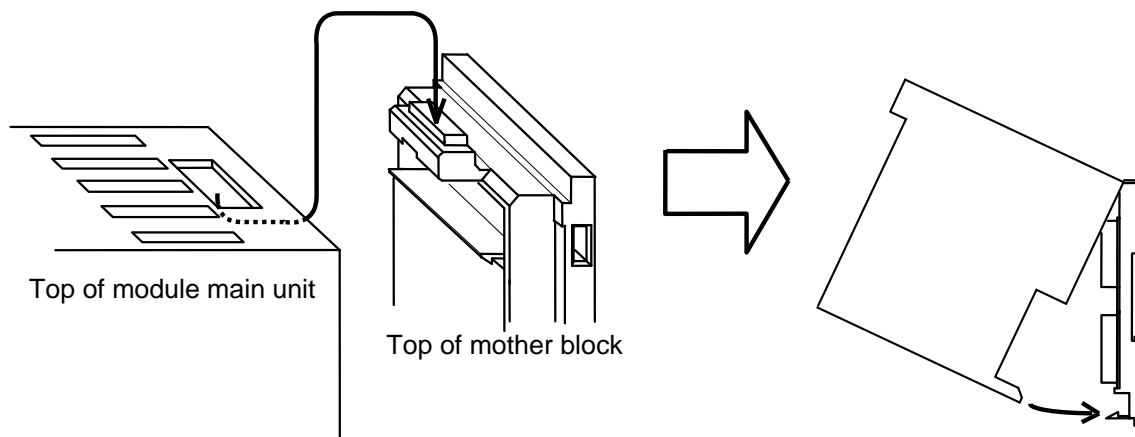

Figure 3

Figure 4

H-LNK-A module

3.5 Removing the Module Mainframe

It detaches the module from the mother block that is mounted on DIN rail or a panel.

To separate the module mainframe from the mother block, press the bottom on the module, lifting upward, to release connection.

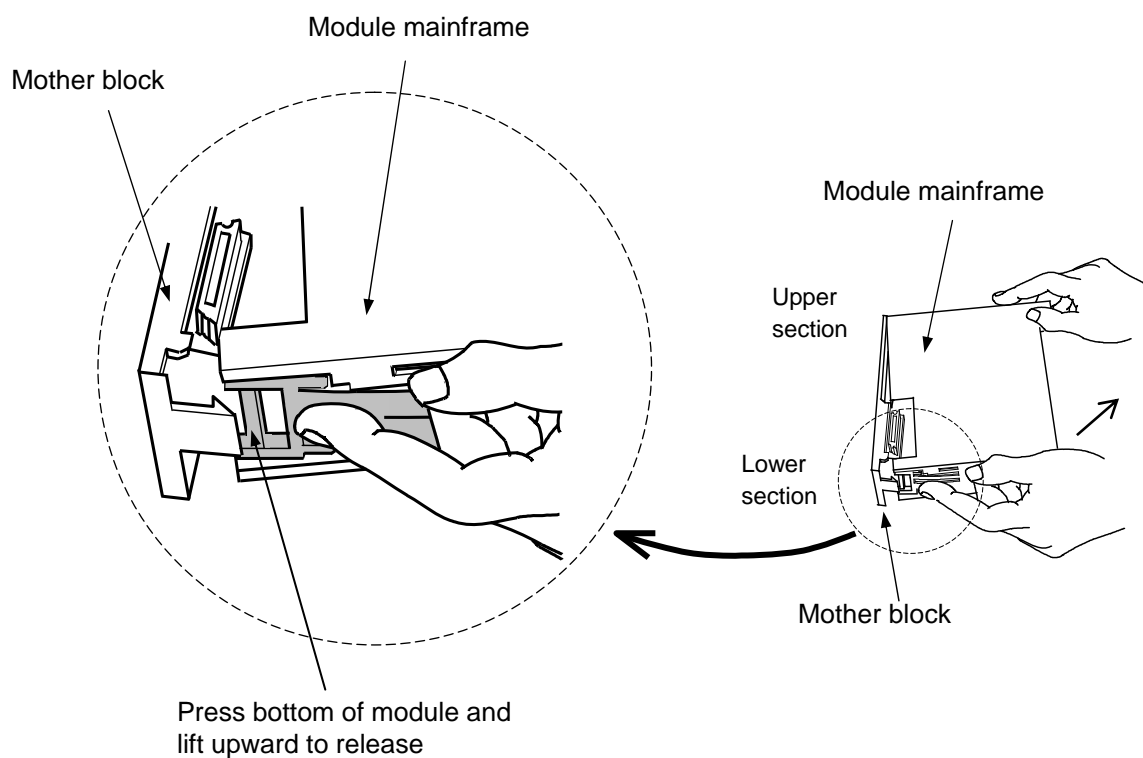

The figures above are for the H-LNK-A module. The H-PCP-G module can also be removed in the same way.

3.6 Terminal Covers

Terminal covers snap on to protect the module terminals. These covers can be permanently secured to the module using a 3 × 8 mm self-tapping round head, taper thread screw. (Customer must provide screws)

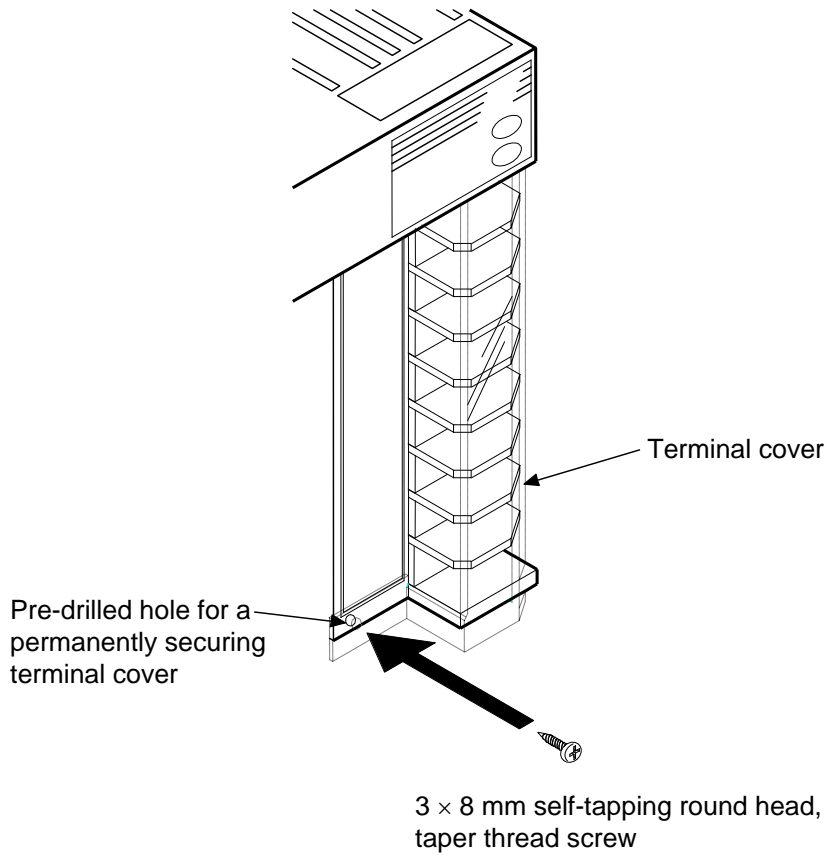

4. WIRING

4.1 Wiring of H-PCP-G Module



WARNING

To prevent electric shock or instrument failure, do not turn on the power until all wiring is completed. Make sure that the wiring is correct before applying power to the instrument.

CAUTION

Power supply wiring:

- Use power supply as specified in power supply rated voltage range.
- Power supply wiring must be twisted and have a low voltage drop.
- Provide separate power supply for this instrument independent of other input/output circuits, motors, equipment and operating circuits.
- If there is electrical noise in the vicinity of the instrument that could affect operation, use a noise filter.
 - Shorten the distance between the twisted power supply wire pitches to achieve the most effective noise reduction.
 - Always install the noise filter on a grounded panel.
 - Minimize the wiring distance between the noise filter output and the instrument power supply terminals to achieve the most effective noise reduction.
 - Do not connect fuses or switches to the noise filter output wiring as this will reduce the effectiveness of the noise filter.
 - Take into consideration the instrument power supply voltage and filter frequency characteristics when selecting the most effective noise filter.
- For an instrument with 24 V power supply input, supply power from “SELV” circuit defined as IEC 60950-1.
- A suitable power supply should be considered in the end-use equipment. The power supply must be in compliance with a limited-energy circuits (maximum available current of 8 A).

Input/output wiring:

- Use independent ducts for the input/output wires and power circuits inside and outside the panel.
- If input/output wires have to be placed in the same duct as the power circuits, use shielded wires. Ground the shield to reject any noise generated by the floating capacitance between the cores and shield or by a grounding potential.

Grounding wiring:

- Use grounding wires with a cross section of 2.0 mm² or more.

FAIL output wiring:

Configure the external relay circuit of the FAIL output so that instrument failure does not affect the entire system. Configuration of an emergency stop circuit is also required to protect the system.

■ Terminal configuration

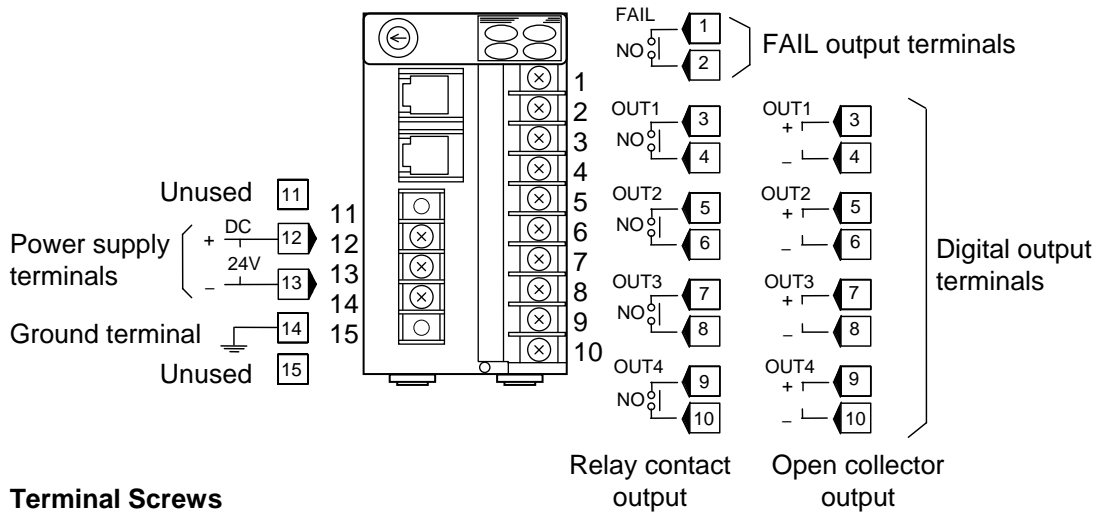

Terminal Screws

Screw size: M3
 Recommended tightening torque: 0.4 N·m (4 kgf·cm)



Use the solderless terminal appropriate to the screw size. If solderless terminal lugs are used, a terminal cover is not kept.

Screw size: M3 × 7

Recommended tightening torque: 0.4 N·m [4 kgf·cm]

Applicable wire: Solid/twisted wire of 0.25 to 1.65 mm²

Specified solderless terminals:

Manufactured by J.S.T MFG CO., LTD.

Circular terminal with isolation V1.25-MS3

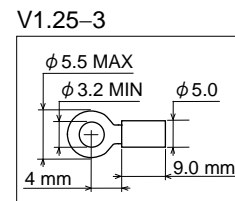

Make sure that during field wiring parts of conductors can not come into contact with adjacent conductive parts.

● **Power supply voltage**

Use a power supply is within the power supply voltage variation range.

21.6 to 26.4 V DC [Power supply voltage range] (Rating: 24 V DC)

● **Ground**

Ground the module using grounding wire with a cross section area of 2.0 mm² or more.

● FAIL output

The FAIL output is output when a problem occurs in the CPU operation of H-PCP-G module and the FAIL lamp will light at the same time. Use this output for FAIL monitoring or for signal output to an external sequencer, etc.

Number of output points: 1 point

Output type: Relay contact output, 1a contact (Open when abnormal)

[Rating: 250 V AC, 0.1 A (Resistive load)]

(CE/UL/cUL (or CSA) approved instrument: 30 V DC, 0.1 A)



When the FAIL condition occurs in any of the function modules in the control unit, the FAIL output will also be output. However in this situation, the FAIL lamp will not light.



If the composition of the control unit is changed (due to the addition, deletion, or changing of the position of the function modules) without carrying out module initialize, the FAIL output will be output. However in this situation, the FAIL lamp will not light.

● Digital output

A digital signal is output when an alarm occurs or a temperature rise completion signal is issued. The types of function signals that are output are 1st alarm, 2nd alarm, heater break alarm, burnout alarm, temperature rise completion signal and control loop break alarm. (Specify when ordering.)

Number of output points: 4

Output types: Relay contact output or open collector output (Specify when ordering.)

The digital output status is stated on the Model No. label attached to the left side of the module as the Model No. and code.

Check the description, and then conduct the wiring accordingly.

- Relay contact output, 1a contact (Closed at alarm occurrence)
[Rating: 250 V AC, 0.1 A (Resistive load)]
(CE/UL/cUL (or CSA) approved instrument: 30 V DC, 0.1 A)
- Open collector output
[Rating: 12 to 24 V DC, Maximum load current: 0.1 A/point, 0.8 A/common]

Wiring example: Open collector output

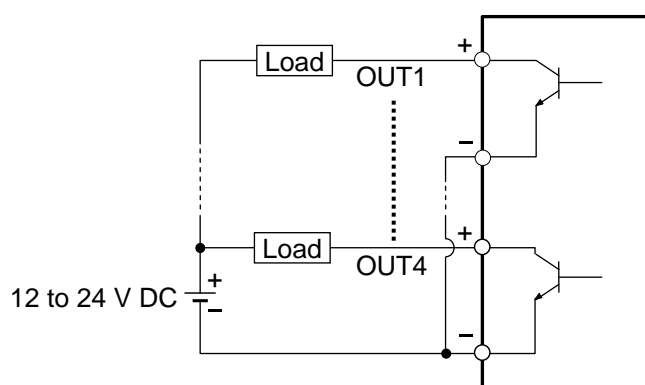

If there is no H-CT module in the control unit, a heater break alarm cannot be selected.



For the control unit consisting of only the H-TIO-H/J modules, a loop break alarm cannot be selected.



For details of the Model No. and code, refer to **1.4 Confirmation of the Model Code (P. 4)**.

4.2 Connection of H-LNK-A Module With Master Station



WARNING

To prevent electric shock or instrument failure, turn off the power before connecting or disconnecting the instrument and peripheral equipment.

CAUTION

- Always connect a terminating resistor between the DA and DB terminals of the module to be located at the far end. Use the terminating resistor attached to the Control & Communication Link master station.
- Never use a T-type branch or star connection.
- Use a twisted pair cable dedicated to Control & Communication Link Ver. 1.10.
- Ground both ends of the shield wire on the twisted pair cable (so that the grounding resistance is 100 Ω or less) via the SLD or FG terminal of each module. In addition, the SLD terminal is internally connected with the FG terminal.
- Do not ground the instrument together with other equipment.
- Use grounding wires with a cross section of 2.0 mm² or more.

The H-LNK-A module is connected to the **Control & Communication Link** master station using a twisted pair cable dedicated to **Control & Communication Link Ver. 1.10**.

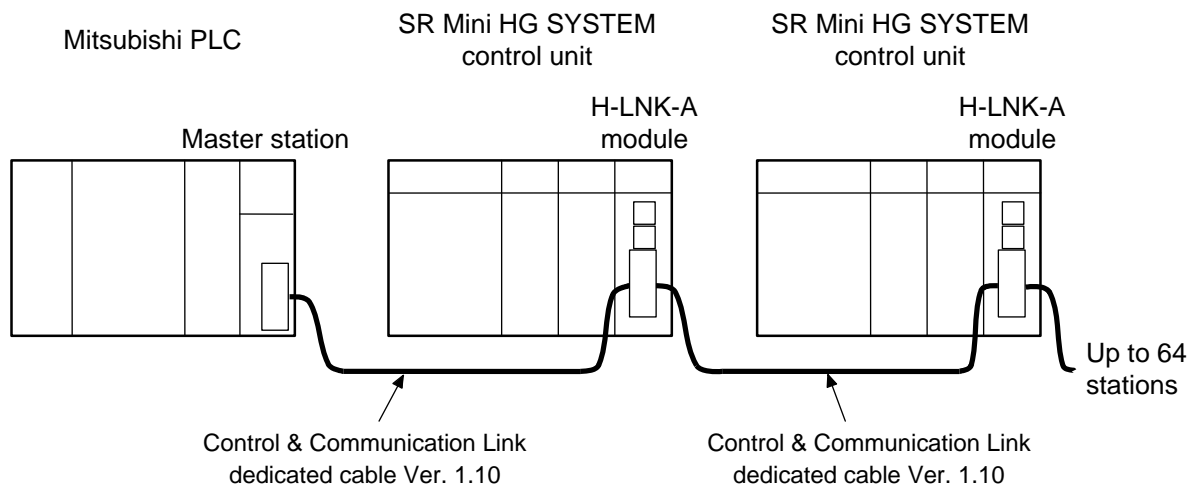

■ Terminal configuration

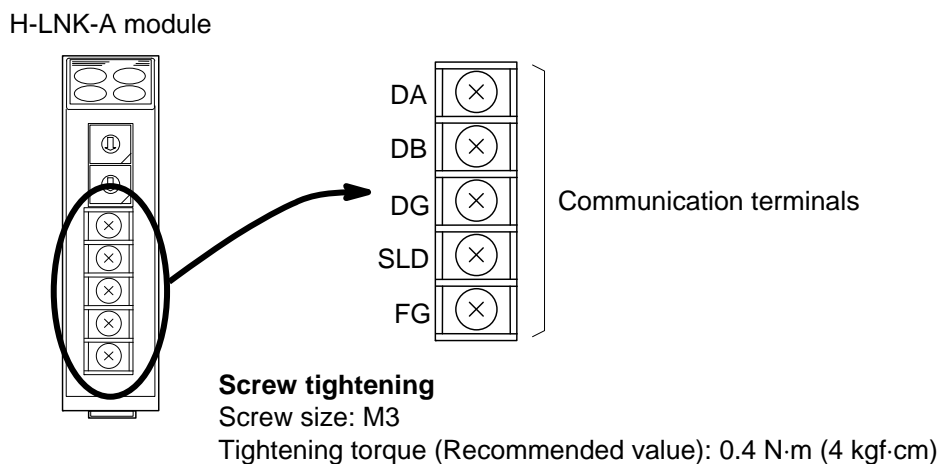

■ Connection diagram

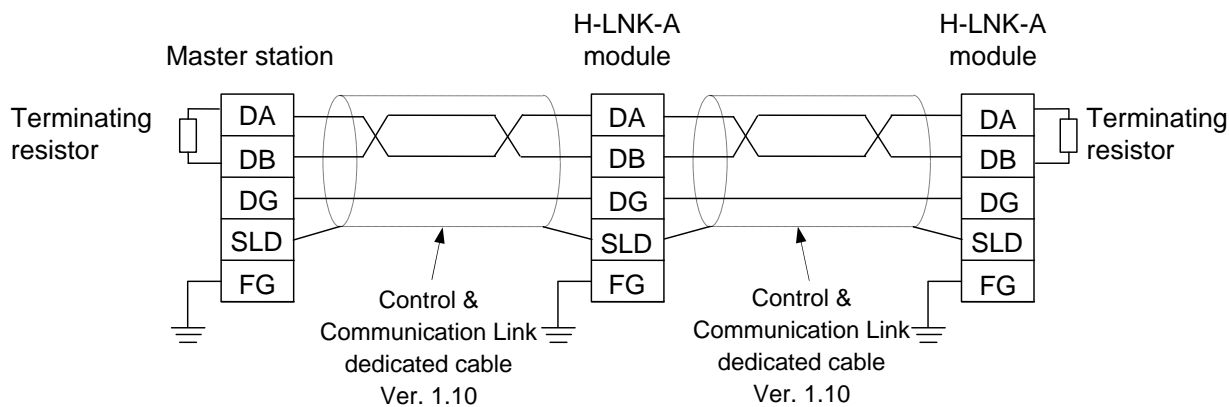

Use the terminating resistor attached to the **Control & Communication Link** master station.

5. PREPARATION BEFORE OPERATION

5.1 Station No. Setting

Set the control unit station No. using the station No. setting switch at the front of the H-LNK-A module. To do this, use a small blade screwdriver.

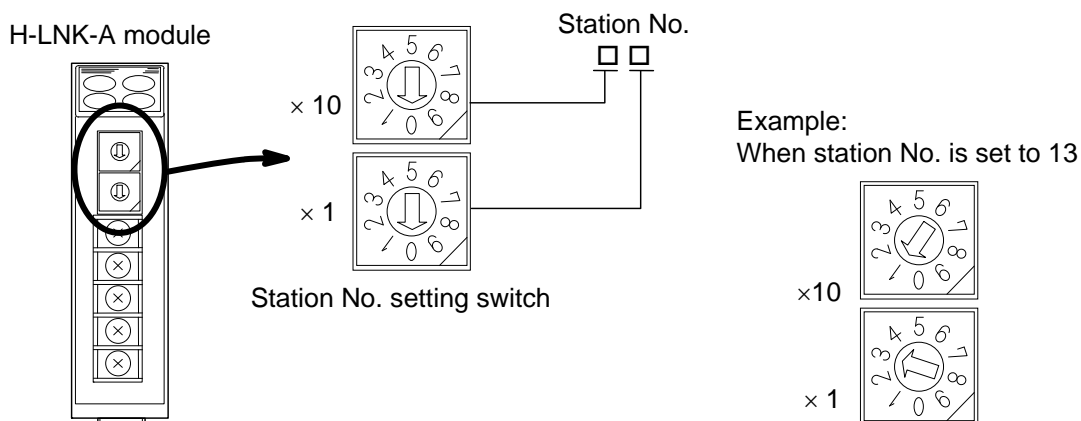

Setting range: 1 to 61 (Factory set value: 0)



- Set each station No. uniquely on the same line.
- Each station No. can be set regardless of the control unit connection order.
- As the H-LNK-A module occupies 4 stations, set the station No. at the head (jumping of 4 stations).

■ Setting example

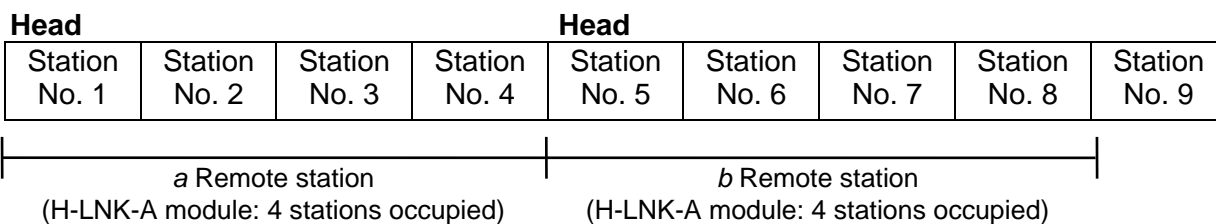
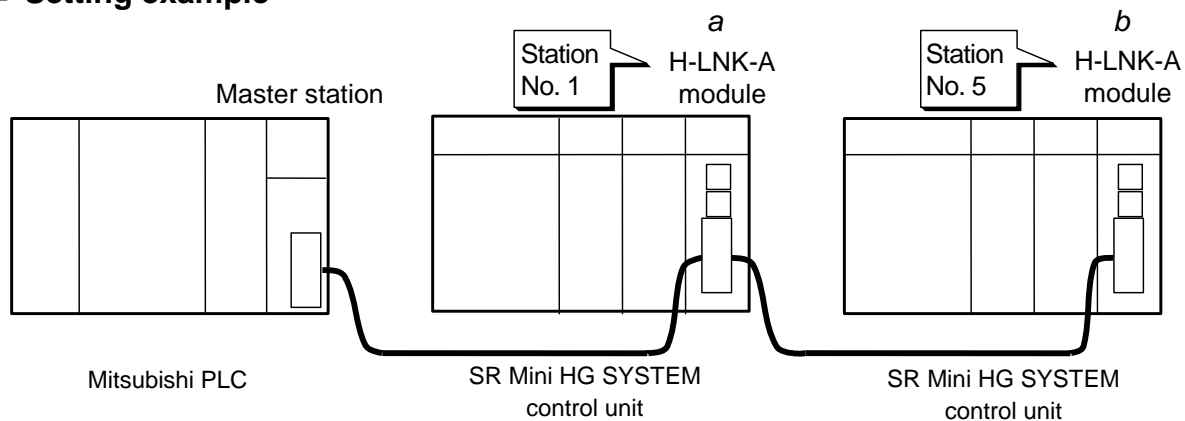

16 temperature control channels every 4 stations.

5.2 Transmission Speed Setting



WARNING

- To prevent electric shock or instrument failure, always turn off the power before setting the switch.
- To prevent electric shock or instrument failure, never touch any section other than those instructed in this manual.

Set the transmission speed between the control unit (H-LNK-A module) and **Control & Communication Link** master station using the transmission speed setting switch at the rear of the H-LNK-A module. To do this, use a small blade screwdriver.



Set the same transmission speed to the **Control & Communication Link** master station and all the H-LNK-A modules on the same line. Otherwise, a normal data link cannot be made.

■ Setting procedure

1. To separate the module mainframe from the mother block, press the bottom on the module, lifting upward, to release connection.

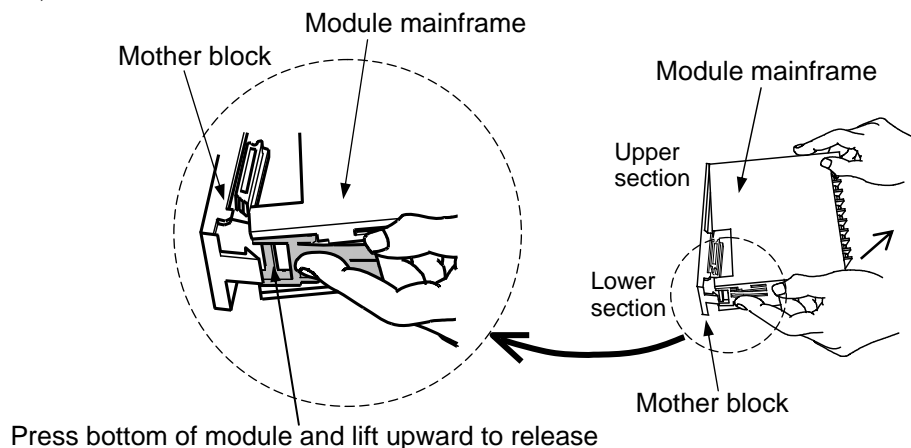

2. Set the transmission speed using the transmission speed setting switch at the rear of the H-LNK-A module.

H-LNK-A module
(Rear)

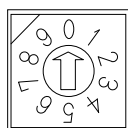
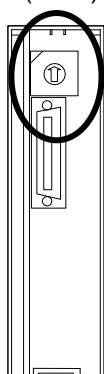

Transmission speed
setting switch

Setting range: 0 to 4
(Factory set value: 0)

- 0: 156 Kbps
- 1: 625 Kbps
- 2: 2.5 Mbps
- 3: 5 Mbps
- 4: 10 Mbps
- 5 to 9: Setting inhibited

3. After completing the setting, engage the upper connection of the mainframe with that of the mother block, then perform the reverse order of separation to engage the lower part of the mainframe with the mother block with the upper connection set to the fulcrum. Firmly engage the mainframe with the mother block until a click sound is produced.



The transmission speed that can be set differs depending on the total extension distance.

Maximum transmission distance	Transmission speed	Transmission speed setting switch setting
1200 m	156 Kbps	0
900 m	625 Kbps	1
400 m	2.5 Mbps	2
160 m	5 Mbps	3
100 m	10 Mbps	4

5.3 Host Communication and Unit Address Settings

When host communication is made between the host computer and control unit, set the host computer communication speed, data configuration and unit address. Set the communication speed and data configuration using the dip switch in the H-PCP-G module. In addition, set the unit address using the unit address setting switch at the front of the H-PCP-G module.



For details of the settings, refer to the separate **Communication Quick Manual (IMS01V02-E□)**.

5.4 When the Power is Turned on for the First Time

■ Checking before power on

Check the following items, and then turn on the power of the control unit.

- Operation environments conform to **3.1 Mounting Cautions (P. 15)**.
- The wiring and connections conform to **4. WIRING (P. 23)**.
- The power supply voltage conform to **2. SPECIFICATIONS (P. 10)**.

■ Checking after power on

Check that the RUN lamps on the H-PCP-G and H-LNK-A modules are flashing.

- 📖 For details of the PLC, refer to the **User's manual for Control & Communication Link system master/local units of Mitsubishi Electric Co., Ltd.**

5.5 Control Unit Operation When the PLC is Abnormal

■ When the Control & Communication Link is not normally connected after the power to the control unit is turned on

As control start (RUN) cannot be set on the PLC side, control continues to stop (STOP).



The control unit starts with control RUN/STOP transfer set to the control STOP state after power on. Set to control RUN on the PLC side after power on. However, if the initialize setting (Extended communication) Control RUN/STOP holding (0: Not holding prior to factory shipment) is changed to 1: Holding, control starts while the state before STOP is being held.

For details of the Control RUN/STOP holding settings, refer to the separate Supplementary Information for initialize settings [Extended Communication] (IMSRM07-E□).

■ When the PLC becomes abnormal while the control unit operates normally

The control unit continues its control at the temperature set value before the PLC becomes abnormal.

6. REMOTE INPUT/OUTPUT AND REMOTE REGISTERS

6.1 Communication Between Master Station and Remote Device Station

The SR Mini HG SYSTEM control unit (hereinafter, temperature control unit) which is a remote device can process remote input (RX), remote output (RY) and remote registers (RWw and RWr).

Outline of communication between master station and remote device station

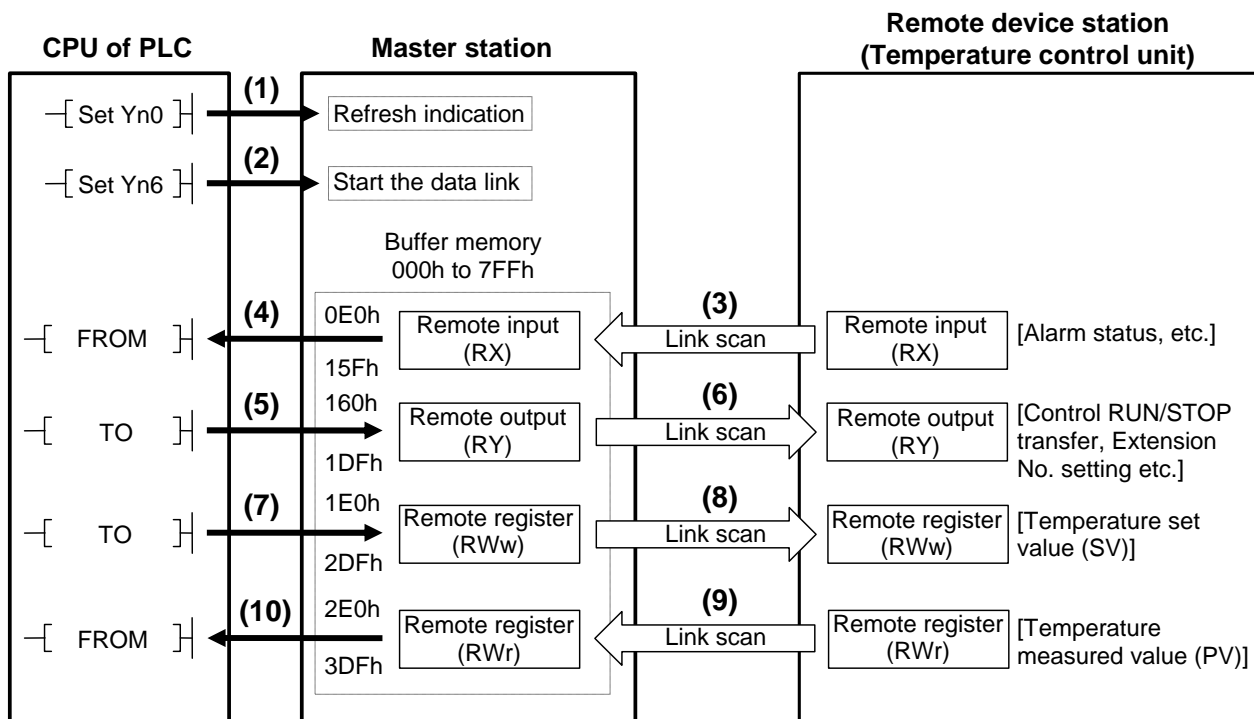

- (1) Turn on the refresh indication.
- (2) Start the data link.
- (3) The remote input (RX) of the remote device station (Temperature control unit) is stored in the remote input (RX) of the master station by link scanning.
- (4) Read the data from the remote input (RX) using the FROM instruction.
- (5) Write the data in the remote output (RY) using the TO instruction.
- (6) The remote output (RY) of the remote device station (Temperature control unit) is turned on/off by link scanning.
- (7) Write the data in the remote register (RWw) using the TO instruction.
- (8) The data is stored in the remote register (RWw) of the remote device station (Temperature control unit) by link scanning.
- (9) The remote register (RWr) of the remote device station (Temperature control unit) is stored in the remote register (RWr) of the master station by link scanning.
- (10) Read the data from the remote register (RWr) using the FROM instruction.

For details of the communication, refer to the **Instruction manual for PLC**.

6.2 Remote Input/Output

Remote input (RX) and output (RY) are ON/OFF data. Remote data corresponds to bit data, and 16-bit data is collectively (word) processed during FROM/TO instruction execution.



“n” in the table is the address assigned to the master station by the station No. setting. It can be calculated by the following equation:

$$n = (\text{Station No.} - 1) \times 2$$

As the calculation result is expressed in decimal digits it is converted to hexadecimal digits before substituted for “n” in the table.

Example: If the station No. of the H-LNK-A module is “1” or “5”

For station No. 1: Remote input RXn0 to RX(n+7)F → RX00 to RX7F

Remote output RYn0 to RY(n+7)F → RY00 to RY7F

For station No. 5: Remote input RXn0 to RX(n+7)F → RX80 to RXFF

Remote output RYn0 to RY(n+7)F → RY80 to RYFF

■ List of remote input (4 stations occupied, Temperature control 16 channels)

Direction: Remote device station (Temperature control unit) → Master station (PLC)

Address	Details	
RXn0	CH1	First alarm status (OFF: Alarm OFF, ON: Alarm ON)
RXn1	CH1	Second alarm status (OFF: Alarm OFF, ON: Alarm ON)
RXn2	CH1	Burnout alarm status (OFF: Alarm OFF, ON: Alarm ON)
RXn3	CH1	Heater break alarm (HBA) status (OFF: Alarm OFF, ON: Alarm ON)
RXn4	CH1	PID/AT transfer status (OFF: PID control, ON: AT <Autotuning>)
RXn5	CH2	First alarm status (OFF: Alarm OFF, ON: Alarm ON)
RXn6	CH2	Second alarm status (OFF: Alarm OFF, ON: Alarm ON)
RXn7	CH2	Burnout alarm status (OFF: Alarm OFF, ON: Alarm ON)
RXn8	CH2	Heater break alarm (HBA) status (OFF: Alarm OFF, ON: Alarm ON)
RXn9	CH2	PID/AT transfer status (OFF: PID control, ON: AT <Autotuning>)
RXnA	Unused	
RXnB	Unused	
RXnC	Extended display completion *	
RXnD	Extended setting completion *	
RXnE	Unused	
RXnF	Hardware error flag ¹	

* For details, refer to **6.5 Flag Operation (P. 51)**.

¹ If hardware error (SR Mini HG error code) occurs: Turned on.

Continued on the next page.

Continued from the previous page.

Direction: Remote device station (Temperature control unit) → Master station (PLC)
[Remote input]

Address	Details	
RX(n+1)0	Unused	
RX(n+1)1	Unused	
RX(n+1)2	Unused	
RX(n+1)3	Unused	
RX(n+1)4	Unused	
RX(n+1)5	Unused	
RX(n+1)6	Unused	
RX(n+1)7	Unused	
RX(n+1)8	Unused	
RX(n+1)9	Unused	
RX(n+1)A	Unused	
RX(n+1)B	Unused	
RX(n+1)C	Unused	
RX(n+1)D	Unused	
RX(n+1)E	Unused	
RX(n+1)F	Unused	
RX(n+2)0	CH3	First alarm status (OFF: Alarm OFF, ON: Alarm ON)
RX(n+2)1	CH3	Second alarm status (OFF: Alarm OFF, ON: Alarm ON)
RX(n+2)2	CH3	Burnout alarm status (OFF: Alarm OFF, ON: Alarm ON)
RX(n+2)3	CH3	Heater break alarm (HBA) status (OFF: Alarm OFF, ON: Alarm ON)
RX(n+2)4	CH3	PID/AT transfer status (OFF: PID control, ON: AT <Autotuning>)
RX(n+2)5	CH4	First alarm status (OFF: Alarm OFF, ON: Alarm ON)
RX(n+2)6	CH4	Second alarm status (OFF: Alarm OFF, ON: Alarm ON)
RX(n+2)7	CH4	Burnout alarm status (OFF: Alarm OFF, ON: Alarm ON)
RX(n+2)8	CH4	Heater break alarm (HBA) status (OFF: Alarm OFF, ON: Alarm ON)
RX(n+2)9	CH4	PID/AT transfer status (OFF: PID control, ON: AT <Autotuning>)
RX(n+2)A	CH5	First alarm status (OFF: Alarm OFF, ON: Alarm ON)
RX(n+2)B	CH5	Second alarm status (OFF: Alarm OFF, ON: Alarm ON)
RX(n+2)C	CH5	Burnout alarm status (OFF: Alarm OFF, ON: Alarm ON)
RX(n+2)D	CH5	Heater break alarm (HBA) status (OFF: Alarm OFF, ON: Alarm ON)
RX(n+2)E	CH5	PID/AT transfer status (OFF: PID control, ON: AT <Autotuning>)
RX(n+2)F	CH6	First alarm status (OFF: Alarm OFF, ON: Alarm ON)

Continued on the next page.

Continued from the previous page.

Direction: Remote device station (Temperature control unit) → Master station (PLC)

[Remote input]

Address	Details	
RX(n+3)0	CH6	Second alarm status (OFF: Alarm OFF, ON: Alarm ON)
RX(n+3)1	CH6	Burnout alarm status (OFF: Alarm OFF, ON: Alarm ON)
RX(n+3)2	CH6	Heater break alarm (HBA) status (OFF: Alarm OFF, ON: Alarm ON)
RX(n+3)3	CH6	PID/AT transfer status (OFF: PID control, ON: AT <Autotuning>)
RX(n+3)4	CH7	First alarm status (OFF: Alarm OFF, ON: Alarm ON)
RX(n+3)5	CH7	Second alarm status (OFF: Alarm OFF, ON: Alarm ON)
RX(n+3)6	CH7	Burnout alarm status (OFF: Alarm OFF, ON: Alarm ON)
RX(n+3)7	CH7	Heater break alarm (HBA) status (OFF: Alarm OFF, ON: Alarm ON)
RX(n+3)8	CH7	PID/AT transfer status (OFF: PID control, ON: AT <Autotuning>)
RX(n+3)9	CH8	First alarm status (OFF: Alarm OFF, ON: Alarm ON)
RX(n+3)A	CH8	Second alarm status (OFF: Alarm OFF, ON: Alarm ON)
RX(n+3)B	CH8	Burnout alarm status (OFF: Alarm OFF, ON: Alarm ON)
RX(n+3)C	CH8	Heater break alarm (HBA) status (OFF: Alarm OFF, ON: Alarm ON)
RX(n+3)D	CH8	PID/AT transfer status (OFF: PID control, ON: AT <Autotuning>)
RX(n+3)E	Unused	
RX(n+3)F	Unused	
RX(n+4)0	CH9	First alarm status (OFF: Alarm OFF, ON: Alarm ON)
RX(n+4)1	CH9	Second alarm status (OFF: Alarm OFF, ON: Alarm ON)
RX(n+4)2	CH9	Burnout alarm status (OFF: Alarm OFF, ON: Alarm ON)
RX(n+4)3	CH9	Heater break alarm (HBA) status (OFF: Alarm OFF, ON: Alarm ON)
RX(n+4)4	CH9	PID/AT transfer status (OFF: PID control, ON: AT <Autotuning>)
RX(n+4)5	CH10	First alarm status (OFF: Alarm OFF, ON: Alarm ON)
RX(n+4)6	CH10	Second alarm status (OFF: Alarm OFF, ON: Alarm ON)
RX(n+4)7	CH10	Burnout alarm status (OFF: Alarm OFF, ON: Alarm ON)
RX(n+4)8	CH10	Heater break alarm (HBA) status (OFF: Alarm OFF, ON: Alarm ON)
RX(n+4)9	CH10	PID/AT transfer status (OFF: PID control, ON: AT <Autotuning>)
RX(n+4)A	CH11	First alarm status (OFF: Alarm OFF, ON: Alarm ON)
RX(n+4)B	CH11	Second alarm status (OFF: Alarm OFF, ON: Alarm ON)
RX(n+4)C	CH11	Burnout alarm status (OFF: Alarm OFF, ON: Alarm ON)
RX(n+4)D	CH11	Heater break alarm (HBA) status (OFF: Alarm OFF, ON: Alarm ON)
RX(n+4)E	CH11	PID/AT transfer status (OFF: PID control, ON: AT <Autotuning>)
RX(n+4)F	CH12	First alarm status (OFF: Alarm OFF, ON: Alarm ON)

Continued on the next page.

Continued from the previous page.

Direction: Remote device station (Temperature control unit) → Master station (PLC)
[Remote input]

Address	Details	
RX(n+5)0	CH12	Second alarm status (OFF: Alarm OFF, ON: Alarm ON)
RX(n+5)1	CH12	Burnout alarm status (OFF: Alarm OFF, ON: Alarm ON)
RX(n+5)2	CH12	Heater break alarm (HBA) status (OFF: Alarm OFF, ON: Alarm ON)
RX(n+5)3	CH12	PID/AT transfer status (OFF: PID control, ON: AT <Autotuning>)
RX(n+5)4	CH13	First alarm status (OFF: Alarm OFF, ON: Alarm ON)
RX(n+5)5	CH13	Second alarm status (OFF: Alarm OFF, ON: Alarm ON)
RX(n+5)6	CH13	Burnout alarm status (OFF: Alarm OFF, ON: Alarm ON)
RX(n+5)7	CH13	Heater break alarm (HBA) status (OFF: Alarm OFF, ON: Alarm ON)
RX(n+5)8	CH13	PID/AT transfer status (OFF: PID control, ON: AT <Autotuning>)
RX(n+5)9	CH14	First alarm status (OFF: Alarm OFF, ON: Alarm ON)
RX(n+5)A	CH14	Second alarm status (OFF: Alarm OFF, ON: Alarm ON)
RX(n+5)B	CH14	Burnout alarm status (OFF: Alarm OFF, ON: Alarm ON)
RX(n+5)C	CH14	Heater break alarm (HBA) status (OFF: Alarm OFF, ON: Alarm ON)
RX(n+5)D	CH14	PID/AT transfer status (OFF: PID control, ON: AT <Autotuning>)
RX(n+5)E	Unused	
RX(n+5)F	Unused	
RX(n+6)0	CH15	First alarm status (OFF: Alarm OFF, ON: Alarm ON)
RX(n+6)1	CH15	Second alarm status (OFF: Alarm OFF, ON: Alarm ON)
RX(n+6)2	CH15	Burnout alarm status (OFF: Alarm OFF, ON: Alarm ON)
RX(n+6)3	CH15	Heater break alarm (HBA) status (OFF: Alarm OFF, ON: Alarm ON)
RX(n+6)4	CH15	PID/AT transfer status (OFF: PID control, ON: AT <Autotuning>)
RX(n+6)5	CH16	First alarm status (OFF: Alarm OFF, ON: Alarm ON)
RX(n+6)6	CH16	Second alarm status (OFF: Alarm OFF, ON: Alarm ON)
RX(n+6)7	CH16	Burnout alarm status (OFF: Alarm OFF, ON: Alarm ON)
RX(n+6)8	CH16	Heater break alarm (HBA) status (OFF: Alarm OFF, ON: Alarm ON)
RX(n+6)9	CH16	PID/AT transfer status (OFF: PID control, ON: AT <Autotuning>)
RX(n+6)A	Unused	
RX(n+6)B	Unused	
RX(n+6)C	Unused	
RX(n+6)D	Unused	
RX(n+6)E	Unused	
RX(n+6)F	Unused	

Continued on the next page.

Continued from the previous page.

Direction: Remote device station (Temperature control unit) → Master station (PLC)

[Remote input]

Address	Details
RX(n+7)0	Reserved
RX(n+7)1	Reserved
RX(n+7)2	Reserved
RX(n+7)3	Reserved
RX(n+7)4	Reserved
RX(n+7)5	Reserved
RX(n+7)6	Reserved
RX(n+7)7	Reserved
RX(n+7)8	Initialize data processing request flag *
RX(n+7)9	Initialize data setting completion flag *
RX(n+7)A	Error status flag *
RX(n+7)B	Remote ready *
RX(n+7)C	Reserved
RX(n+7)D	Reserved
RX(n+7)E	Reserved
RX(n+7)F	Reserved

* For details, refer to **6.5 Flag Operation (P. 51)**.

■ **List of remote output (4 stations occupied, Temperature control 16 channels)**

Direction: Master station (PLC) → Remote device station (Temperature control unit)

Address	Details	
RYn0	b0	Extension No. setting for display *
RYn1	b1	
RYn2	b2	
RYn3	b3	
RYn4	b4	
RYn5	b5	
RYn6	b0	Extension No. setting for setting *
RYn7	b1	
RYn8	b2	
RYn9	b3	
RYnA	b4	
RYnB	b5	
RYnC	Extended display flag ¹	
RYnD	Extended setting flag ¹	
RYnE	Unused	
RYnF	Control RUN/STOP transfer (OFF: Control stop, ON: Control run)	

* RYn0 to RYn5 (b0 to b5) and RYn6 to RYnB (b0 to b5) bit patterns become as follows.

Extension No. for display

RYn5	RYn4	RYn3	RYn2	RYn1	RYn0
b5	b4	b3	b2	b1	b0

Extension No. for setting

RYnB	RYnA	RYn9	RYn8	RYn7	RYn6
b5	b4	b3	b2	b1	b0

Example: Extension No. for setting is set to “49.”

b5	b4	b3	b2	b1	b0
1	1	0	0	0	1



RYnB	RYnA	RYn9	RYn8	RYn7	RYn6
ON	ON	OFF	OFF	OFF	ON

¹ For details, refer to **6.5 Flag Operation (P. 51)**.

Continued on the next page.

Continued from the previous page.

Direction: Master station (PLC) → Remote device station (Temperature control unit)
[Remote output]

Address	Details
RY(n+1)0	Unused
RY(n+1)1	Unused
RY(n+1)2	Unused
RY(n+1)3	Unused
RY(n+1)4	Unused
RY(n+1)5	Unused
RY(n+1)6	Unused
RY(n+1)7	Unused
RY(n+1)8	Unused
RY(n+1)9	Unused
RY(n+1)A	Unused
RY(n+1)B	Unused
RY(n+1)C	Unused
RY(n+1)D	Unused
RY(n+1)E	Unused
RY(n+1)F	Unused
RY(n+2)0	Unused
RY(n+2)1	Unused
RY(n+2)2	Unused
RY(n+2)3	Unused
RY(n+2)4	Unused
RY(n+2)5	Unused
RY(n+2)6	Unused
RY(n+2)7	Unused
RY(n+2)8	Unused
RY(n+2)9	Unused
RY(n+2)A	Unused
RY(n+2)B	Unused
RY(n+2)C	Unused
RY(n+2)D	Unused
RY(n+2)E	Unused
RY(n+2)F	Unused

Continued on the next page.

Continued from the previous page.

Direction: Master station (PLC) → Remote device station (Temperature control unit)
[Remote output]

Address	Details
RY(n+3)0	Unused
RY(n+3)1	Unused
RY(n+3)2	Unused
RY(n+3)3	Unused
RY(n+3)4	Unused
RY(n+3)5	Unused
RY(n+3)6	Unused
RY(n+3)7	Unused
RY(n+3)8	Unused
RY(n+3)9	Unused
RY(n+3)A	Unused
RY(n+3)B	Unused
RY(n+3)C	Unused
RY(n+3)D	Unused
RY(n+3)E	Unused
RY(n+3)F	Unused
RY(n+4)0	Unused
RY(n+4)1	Unused
RY(n+4)2	Unused
RY(n+4)3	Unused
RY(n+4)4	Unused
RY(n+4)5	Unused
RY(n+4)6	Unused
RY(n+4)7	Unused
RY(n+4)8	Unused
RY(n+4)9	Unused
RY(n+4)A	Unused
RY(n+4)B	Unused
RY(n+4)C	Unused
RY(n+4)D	Unused
RY(n+4)E	Unused
RY(n+4)F	Unused

Continued on the next page.

Continued from the previous page.

Direction: Master station (PLC) → Remote device station (Temperature control unit)
[Remote output]

Address	Details
RY(n+5)0	Unused
RY(n+5)1	Unused
RY(n+5)2	Unused
RY(n+5)3	Unused
RY(n+5)4	Unused
RY(n+5)5	Unused
RY(n+5)6	Unused
RY(n+5)7	Unused
RY(n+5)8	Unused
RY(n+5)9	Unused
RY(n+5)A	Unused
RY(n+5)B	Unused
RY(n+5)C	Unused
RY(n+5)D	Unused
RY(n+5)E	Unused
RY(n+5)F	Unused
RY(n+6)0	Unused
RY(n+6)1	Unused
RY(n+6)2	Unused
RY(n+6)3	Unused
RY(n+6)4	Unused
RY(n+6)5	Unused
RY(n+6)6	Unused
RY(n+6)7	Unused
RY(n+6)8	Unused
RY(n+6)9	Unused
RY(n+6)A	Unused
RY(n+6)B	Unused
RY(n+6)C	Unused
RY(n+6)D	Unused
RY(n+6)E	Unused
RY(n+6)F	Unused

Continued on the next page.

Continued from the previous page.

Direction: Master station (PLC) → Remote device station (Temperature control unit)

[Remote output]

Address	Details
RY(n+7)0	Reserved
RY(n+7)1	Reserved
RY(n+7)2	Reserved
RY(n+7)3	Reserved
RY(n+7)4	Reserved
RY(n+7)5	Reserved
RY(n+7)6	Reserved
RY(n+7)7	Reserved
RY(n+7)8	Initialize data processing completion flag *
RY(n+7)9	Initialize data setting request flag *
RY(n+7)A	Error reset request flag *
RY(n+7)B	Reserved
RY(n+7)C	Reserved
RY(n+7)D	Reserved
RY(n+7)E	Reserved
RY(n+7)F	Reserved

* For details, refer to **6.5 Flag Operation (P. 51)**.

6.3 Remote Registers

Remote registers (RW_r and RW_w) are numerical data.



“n” and “m” in the table are the addresses assigned to the master station by the station No. setting. They can be calculated by the following equations:

$$n = (\text{Station No.} - 1) \times 4 \quad m = (\text{Station No.} - 1) \times 4$$

As the calculation results are expressed in decimal digits, they are converted to hexadecimal digits before substituted for “n” and “m” in the table.

Example: If the station No. of the H-LNK-A module is “1” or “5”

For station No. 1: Remote register RW_r_n to RW_r_n+F → RW_r0 to RW_rF

RW_w_m to RW_w_m+F → RW_w0 to RW_wF

For station No. 5: Remote register RW_r_n to RW_r_n+F → RW_r10 to RW_r1F

RW_w_m to RW_w_m+F → RW_w10 to RW_w1F

■ List of remote register

(4 stations occupied, Temperature control 16 channels)

Direction: Remote device station (Temperature control unit) → Master station (PLC)

[RW_r]

Address	Details	
RW _r _n	CH1	Data specified by the Extension No. setting for display [RY _n 0 to RY _n 5] * For details of the Extension No. and data, refer to 6.4 Extension No. (P. 45) .
RW _r _n +1	CH2	
RW _r _n +2	CH3	
RW _r _n +3	CH4	
RW _r _n +4	CH5	
RW _r _n +5	CH6	
RW _r _n +6	CH7	
RW _r _n +7	CH8	
RW _r _n +8	CH9	
RW _r _n +9	CH10	
RW _r _n +A	CH11	
RW _r _n +B	CH12	
RW _r _n +C	CH13	
RW _r _n +D	CH14	
RW _r _n +E	CH15	
RW _r _n +F	CH16	

* For details, refer to page 44.

Direction: Master station (PLC) → Remote device station (Temperature control unit)

[RWw]

Address	Details	
RWwm	CH1	Data specified by the Extension No. setting for setting [RYn6 to RYnB] * For details of the Extension No. and data, refer to 6.4 Extension No. (P. 45) .
RWwm+1	CH2	
RWwm+2	CH3	
RWwm+3	CH4	
RWwm+4	CH5	
RWwm+5	CH6	
RWwm+6	CH7	
RWwm+7	CH8	
RWwm+8	CH9	
RWwm+9	CH10	
RWwm+A	CH11	
RWwm+B	CH12	
RWwm+C	CH13	
RWwm+D	CH14	
RWwm+E	CH15	
RWwm+F	CH16	

* Data on the Extension No. specified by the remote output [RYn0 to RYn5 or RYn6 to RYnB] is processed.

Example: When Extension No. for display is set to “1” or Extension No. for setting is set to “9.”

Extension No. for display: Set to “1”

RYn5	RYn4	RYn3	RYn2	RYn1	RYn0
OFF	OFF	OFF	OFF	OFF	ON

→ **Extension No. 1:
Manipulated output
(Heat-side)**

Remote registers [RWrn to RWrn+F] become the Manipulated output (Heat-side) of CH1 to CH16.

Extension No. for setting: Set to “9”

RYnB	RYnA	RYn9	RYn8	RYn7	RYn6
OFF	OFF	ON	OFF	OFF	ON

→ **Extension No. 9:
1st alarm set value**

Remote registers [RWwm to RWwm+F] become the 1st alarm set values of CH1 to CH16.

 For details of the remote output [RYn0 to RYn5 or RYn6 to RYnB], refer to **6.2 Remote Input/Output (P. 33)**.



Unused channels become as follows.

Remote registers, RWrn to RWrn+F → “0” is displayed.

Remote registers, RWwm to RWwm+F → Set data is ignored.

6.4 Extension No.

The Extension No. is that specified by the remote output [RYn0 to RYn5 or RYn6 to RYnB] to select data processed by the remote register.

If the necessary data is selected from the following table and its Extension No. is specified by the remote output [RYn0 to RYn5 or RYn6 to RYnB], it can be processed by the remote register.

■ List of Extension Nos.

Attribute

RO: Read only

Direction: Remote device station (Temperature control unit) → Master station (PLC)

WO: Write only

Direction: Remote device station (Temperature control unit) ← Master station (PLC)

R/W: Common to read and write

Direction: Remote device station (Temperature control unit) ↔ Master station (PLC)

Extension No.	Name	Attribute	Data range	Description	Factory set value
0	Temperature measured value (PV)	RO	Within input range	Displays the temperature measured value.	–
1	Manipulated output (Heat-side)	RO	–5.0 to +105.0 %	Displays the manipulated output on the heat-side.	–
2	CT input measured value *	RO	0.0 to 30.0 A: CTL-6 type 0.0 to 100.0 A: CTL-12 type	Displays the current measured value detected by the CT sensor of the H-CT-A module.	–
3	Temperature set value (SV)	R/W	Within input range (Within setting limiter range)	Sets the target value in temperature control.	0
4	PID/AT transfer	R/W	0: PID control 1: Autotuning (AT)	Selects PID control or autotuning (AT). If “1” is selected, AT immediately starts. In addition, suspends AT immediately when “0” is set during autotuning (AT) execution.	0
5	Proportional band (Heat-side)	R/W	0.1 to 1000.0 % of span	Sets the proportional band (heat-side) in P, PI or PID control (including heat/cool PID control).	3.0
6	Integral time (I)	R/W	1 to 3600 seconds	Sets the integral time to eliminate offset occurring in proportional control.	240

* For details of the heater break alarm function, refer to page 49.

Continued on the next page.

6. REMOTE INPUT/OUTPUT AND REMOTE REGISTERS

Continued from the previous page.

Extension No.	Name	Attribute	Data range	Description	Factory set value
7	Derivative time (D)	R/W	0 to 3600 seconds (0: PI control)	Sets the derivative time which predicts output changes in proportional control to prevent ripples and thus improve control stability.	60
8	PV bias	R/W	-5.00 to +5.00 % of span	Sets the bias added to the measured value to perform sensor correction.	0.00
9	First alarm set value	R/W	Within input range or within span range	Sets the first alarm set value.	Differs depending on the specification.
10	Second alarm set value	R/W	Within input range or within span range	Sets the second alarm set value.	
11	Cannot be used.	-	-	-	-
12	Cannot be used.	-	-	-	-
13	Cannot be used.	-	-	-	-
14	Cannot be used.	-	-	-	-
15	Cannot be used.	-	-	-	-
16	Cannot be used.	-	-	-	-
17	Control RUN/STOP status	RO	0: Control stop 1: Control run	Displays the control run or stop status. Only [RWrn] data is effective. Control is started or stopped by remote output [RYnF].	-
18	Proportioning cycle time (Heat-side)	R/W	1 to 100 seconds	Sets the proportioning cycle time (heat-side) in P, PI or PID control (including heat/cool PID control). Setting will be invalid with output of current/voltage.	20 ^a
19	Auto/Manual transfer	R/W	0: Auto 1: Manual	Performs Auto (normal automatic control operation)/Manual (manual control operation) transfer.	0

^a Relay contact output: 20 seconds
Voltage pulse output, open collector output, triac output: 2 seconds
For current/voltage output: Setting is ineffective.

Continued on the next page.

Continued from the previous page.

Extension No.	Name	Attribute	Data range	Description	Factory set value
20	Manual output value	R/W	-5.0 to +105.0 %	Sets the manual output value.	0.0
21	Cannot be used.	-	-	-	-
22	Cannot be used.	-	-	-	-
23	Cannot be used.	-	-	-	-
24	Heater break alarm (HBA) set value *	R/W	0 to 30.0 A: CTL-6 type 0.0 to 100.0 A: CTL-12 type	Sets the heater break alarm set value for the CT input of the H-CT-A module.	0.0
25	Decimal-point position	RO	0: No decimal point 1: 1 digit below decimal point 2: 2 digits below decimal point 3: 3 digits below decimal point	Displays the position of the decimal point of the temperature measured value, temperature set value and alarm set value.	-
26	Manipulated output (Cool-side)	RO	-5.0 to +105.0 %	Displays the manipulated output on the cool-side.	-
27	Proportional band (Cool-side)	R/W	0.1 to 1000.0 % of span	Sets the proportional band (cool-side) in heat/cool PID control.	3.0
28	Proportioning cycle time (Cool-side)	R/W	1 to 100 seconds	Sets the proportioning cycle time (cool-side) in heat/cool PID control. Setting will be invalid with output of current/voltage and heat action.	20 ^a
29	Overlap/Deadband	R/W	-10.0 to +10.0 % of span	Sets the control deadband between proportional bands (heat-side and cool-side) in heat/cool PID control. Overlapped if minus (-) is set.	0.0

* For details of the heater beak alarm function, refer to page 49.

^a Relay contact output: 20 seconds

Voltage pulse output, open collector output, triac output: 2 seconds

For current/voltage output: Setting is ineffective.

Continued on the next page.

6. REMOTE INPUT/OUTPUT AND REMOTE REGISTERS

Continued from the previous page.

Extension No.	Name	Attribute	Data range	Description	Factory set value
30	Operation mode setting	R/W	0: Unused 1: Only monitoring 2: Only monitoring and alarm 3: Normal	Selects the temperature control channel operation mode.	3
31	Set value monitoring	RO	Within input range	Displays the set value now used for control. If the function of limiting the rate of setting change is used, indicates the set value now changing.	—
32	Error code	RO	For details of the data, Refer to page 50.	Displays the error code during system error occurrence at operation or power on. Only [RWrn] data is effective.	—
33	Memory area number	R/W	1 to 8	Changes the control area. Monitor: Only [RWrn] data is effective. Setting: Only [RWwm] data is effective.	1
34	Control response designation parameters	R/W	0: Slow 1: Medium 2: Fast	Sets the control response designation parameter in PID control.	0 *
35	Cannot be used.	—	—	—	—
36	Cannot be used.	—	—	—	—
37	Cannot be used.	—	—	—	—
38	Cannot be used.	—	—	—	—
39	Cannot be used.	—	—	—	—
40	Cannot be used.	—	—	—	—
41	Cannot be used.	—	—	—	—
42	Cannot be used.	—	—	—	—
43	Cannot be used.	—	—	—	—
44	Cannot be used.	—	—	—	—

* Heat control: 0 (Slow)
Heat/cool control: 2 (Fast)

Continued on the next page.

Continued from the previous page.

Extension No.	Name	Attribute	Data range	Description	Factory set value
45	Cannot be used.	–	–	–	–
46	Cannot be used.	–	–	–	–
47	Cannot be used.	–	–	–	–
48	Control loop break alarm (LBA) status	RO	0: Alarm off 1: Alarm on	Displays the output status of the control loop break alarm (LBA).	–
49	Loop break alarm (LBA) use selection	R/W	0: Unused 1: Used	Sets use/unuse of the control loop break alarm (LBA).	0
50	LBA time setting	R/W	1 to 7200 seconds	Sets the loop break alarm (LBA) time.	480
51	LBA Deadband	R/W	Input span	Sets the region in which no loop break alarm (LBA) is issued	0
52	Cannot be used.	–	–	–	–
53	Cannot be used.	–	–	–	–
54	Cannot be used.	–	–	–	–
55	Cannot be used.	–	–	–	–
56	Cannot be used.	–	–	–	–
57	Cannot be used.	–	–	–	–
58	Cannot be used.	–	–	–	–
59	Cannot be used.	–	–	–	–
60	Cannot be used.	–	–	–	–
61	Cannot be used.	–	–	–	–
62	Cannot be used.	–	–	–	–
63	Cannot be used.	–	–	–	–

● Heater break alarm function

The current transformer (CT) input measured value [Extension No.2] and heater break alarm set value [Extension No.24] are used by the heater break alarm function. The heater break alarm set value is set to about 85 % of the current transformer (CT) input measured value. However, for a heater having a slightly delayed current rise characteristic, change the set value by lowering the set value if necessary.

Heater break alarm function:

The presence or absence of heater break is determined by comparing the current flowing through the heater (current transformer input measured value: Extension No. 2) to the current preset and assumed to be abnormal (heater break alarm set value: Extension No. 24). The presence or absence of heater break can be recognized by the ON/OFF condition of the heater break alarm (remote input).

Continued on the next page.

Continued from the previous page.

CAUTION

The heater break alarm function in this instrument cannot be used with continuous analog output.

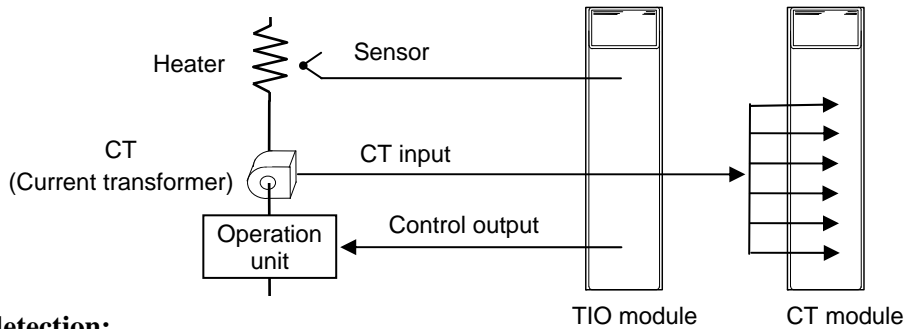

Break detection:

If the current transformer input measured value read from the CT is smaller than the preset heater break alarm set value even with the control output produced, the heater break alarm is turned on.

Welding detection:

If the current transformer input measured value read from the CT is larger than the preset heater break alarm set value even with the control output produced, the heater break alarm is turned on.

● **Data of error code**

The error code [Extension No. 32] bit pattern becomes as follows.

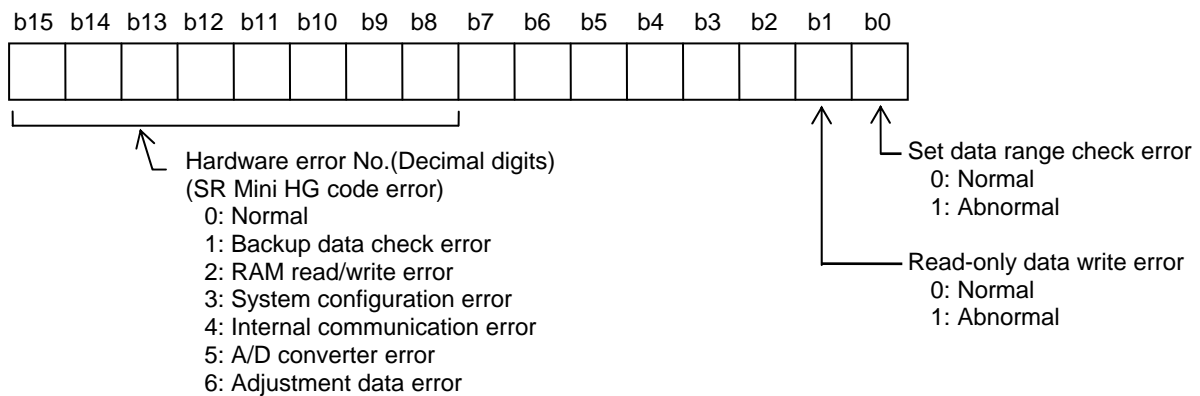

When temperature control channel related setting data are written into the remote device station (temperature control modules) by the master station (PLC), make sure all the temperature control channel related setting data are set within the setting range.

Any single data set outside the setting range may cause b0 (Set data range check error) to become 1 (abnormal).

Even if the setting data belongs to the channel not used by the user, as long as the data exists outside the setting range, b0 (Set data range check error) becomes 1 (abnormal).



“1: Backup data check error,” “2: RAM read/write error” or “4: Internal communication error” may not be recognized by the H-LNK-A module if the H-PCP module cannot recognize the H-LNK-A module.



If a hardware error (SR Mini HG error code) occurs, the remote input hardware error flag [RXnF] is turned on.

6.5 Flag Operation

Remote input/output and remote register flag operations are as follows.

■ Initialize request processing at power on

Initialize processing request from remote device station (Temperature control unit).

If the SR Mini HG is initialized at power on, the initialize data processing request flag [RX(n+7)8] is turned on. Thus, turn on the initialize data processing completion flag [RY(n+7)8].

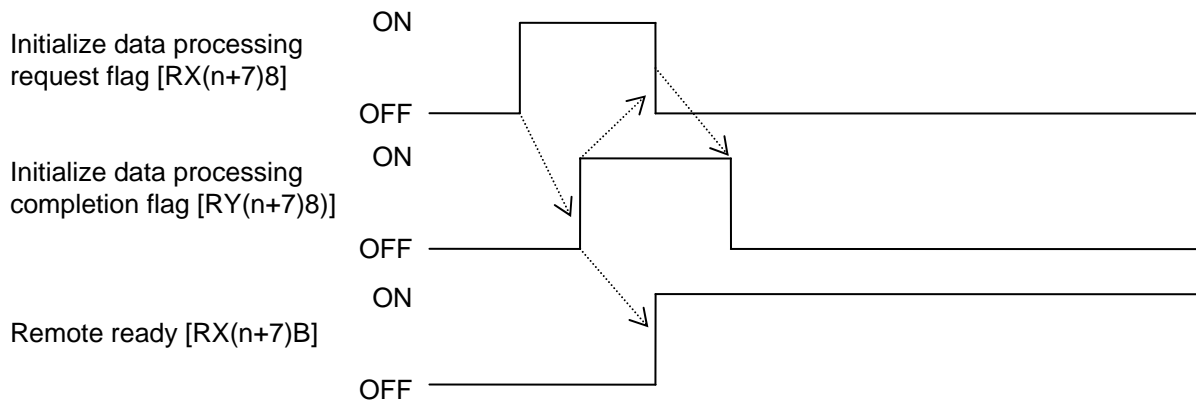

Initialize processing request from master station (PLC)

This is an SR Mini HG initialize setting request. As there is no initialize data specifically, no processing is required.

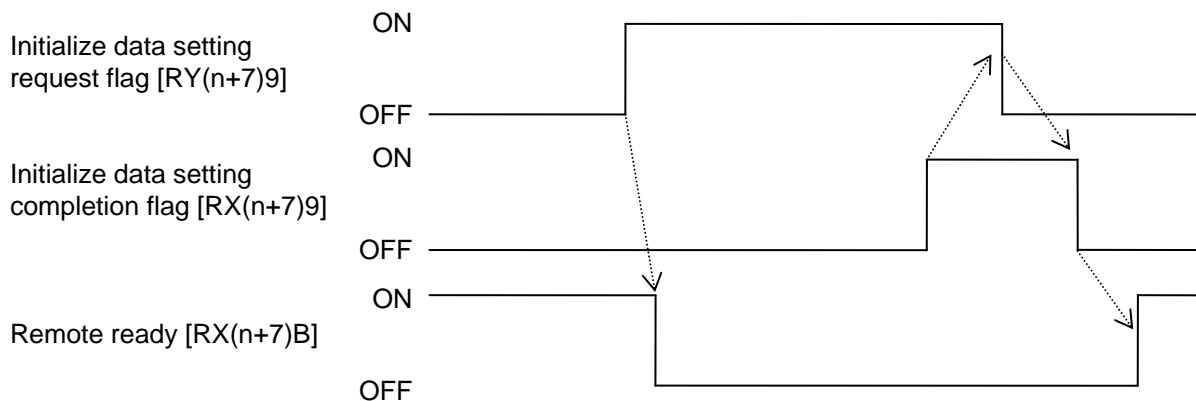

■ **Error flag/error reset processing**

When the error status flag [RX(n+7)A] is turned on, the error code is stored in the remote register. If the error reset request flag [RY(n+7)A] is turned on when an error occurs, [RX(n+7)A] is turned off to clear the error code.

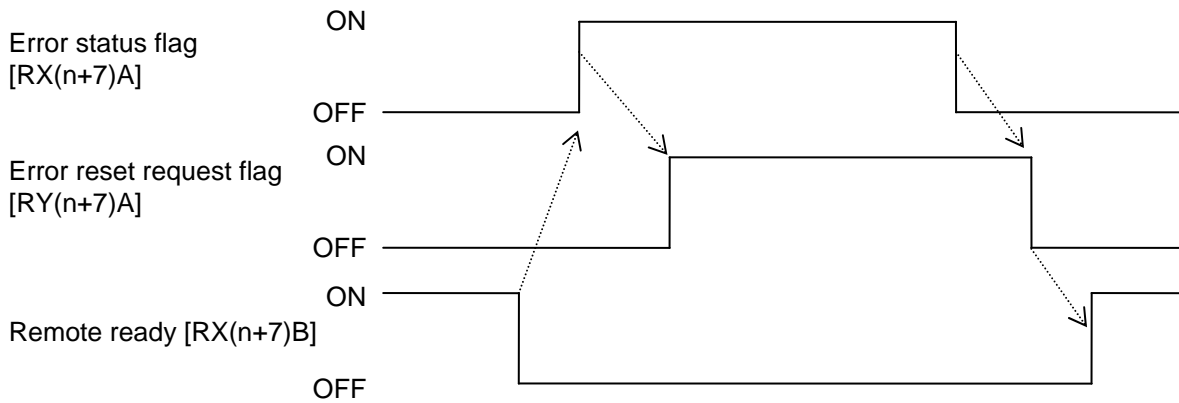

■ **Extension No. for display selection processing**

The content of the extended display remote register is selected.

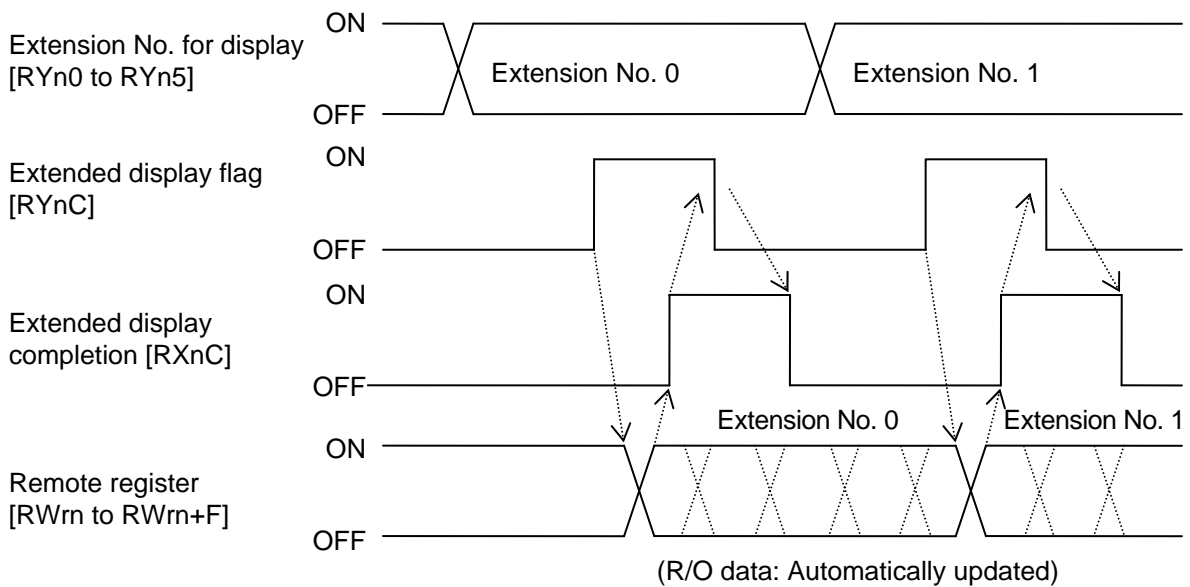

■ Extension No. for setting selection processing

The content of the extended setting remote register is selected and the set value is changed.

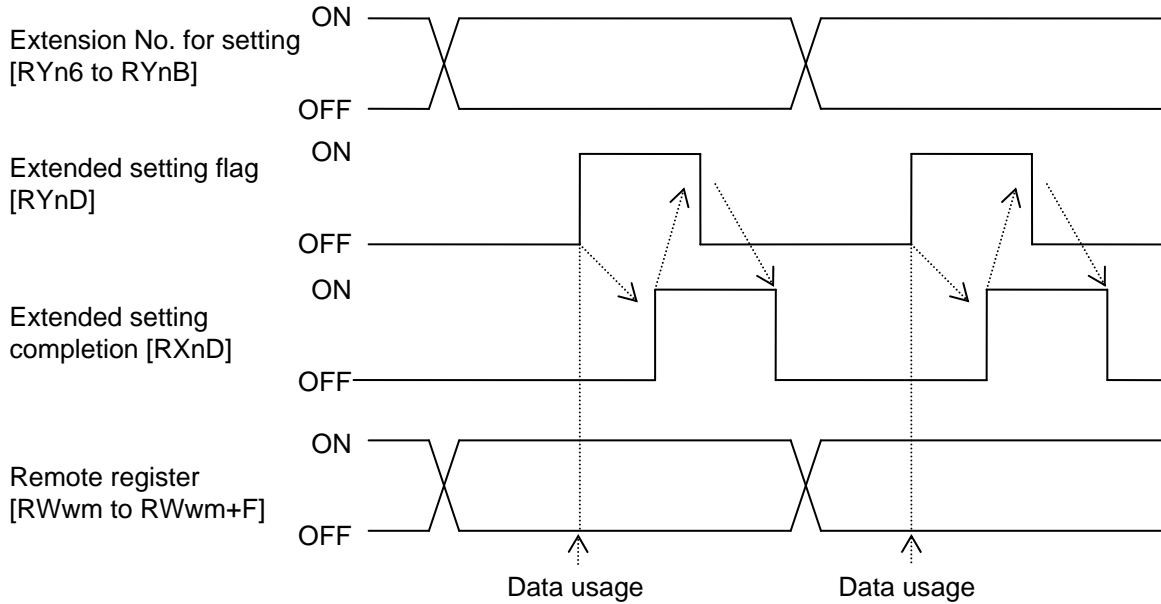

■ AT start procedure (Example of CH1)

Instructs AT execution.

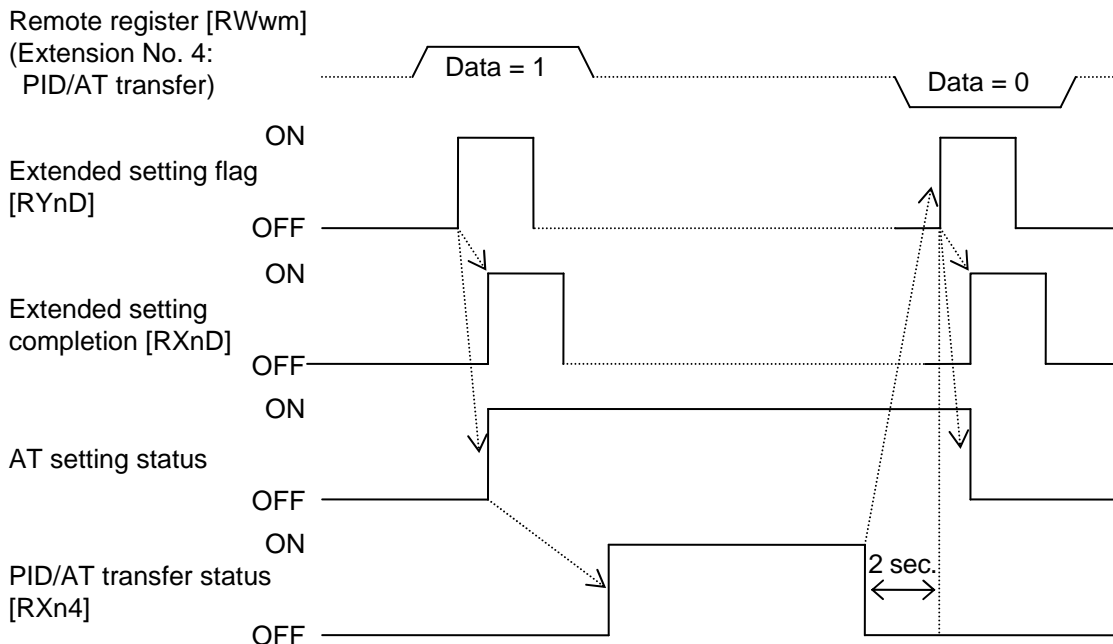

■ Cautions when selecting the memory area

When selecting the memory area, two seconds are required to update data items such as set values (SV) and PID constants. Read the above data items after a lapse of more than two seconds.

7. EXAMPLES OF SEQUENCE PROGRAMS

This Chapter describes examples of sequence programs in the following system configuration.

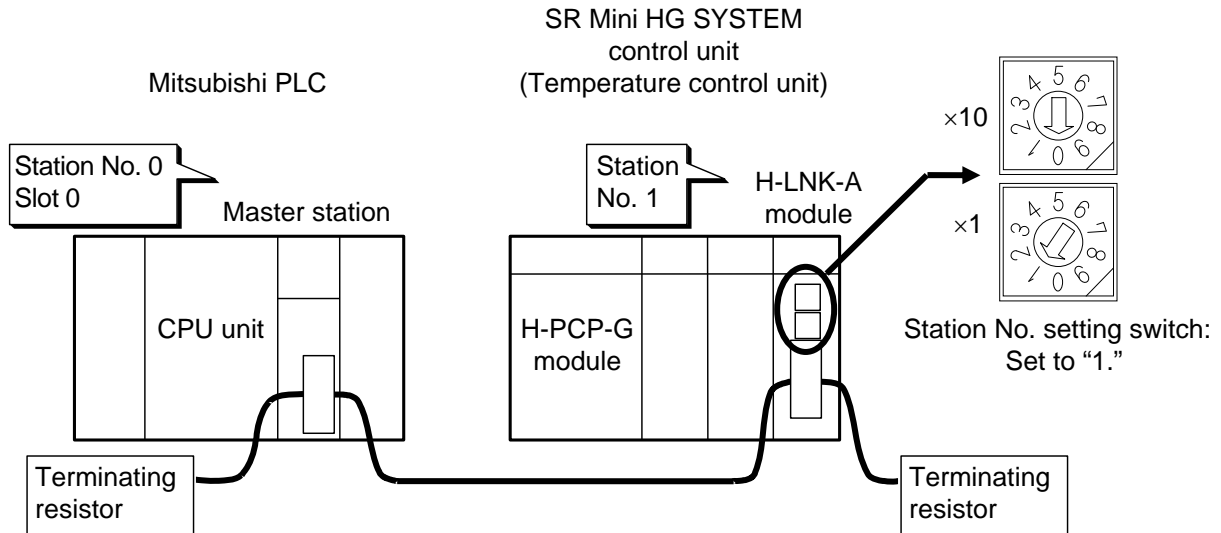

Control & Communication Link system master/local unit (Master station)

Station No.: 0 Slot: 0

SR Mini HG SYSTEM H-LNK-A module

Station No.: 1 (4 stations occupied)

System configuration used for examples of sequence programs



The control unit (Temperature control unit) starts with control RUN/STOP transfer set to the control STOP state after power on. Set to control RUN on the PLC side after power on.

However, if the initialize setting (Extended communication) Control RUN/STOP holding (0: Not holding prior to factory shipment) is changed to “1: Holding,” control starts while the state before STOP is being held.

For details of the Control RUN/STOP holding settings, refer to the separate Supplementary Information for initialize settings (Extended Communication) (IMSRM07-E□).



When the control STOP state is changed to the control RUN state, set the setting flag after a delay time of about 5 seconds by using a timer for initialize processing in the temperature control unit.

7.1 List of Internal Relays (M) and Data Registers (D)

■ List of internal relays (M)

Number	Details	
M0	Unused	
M1	Initialize	
M2		
M3		
M4	Unused	
M5		
M6		
M7		
M8		
M9		
M10		
M11	b0	RYn0
M12	b1	RYn1
M13	b2	RYn2
M14	b3	RYn3
M15	b4	RYn4
M16	b5	RYn5
M17	b0	RYn6
M18	b1	RYn7
M19	b2	RYn8
M20	b3	RYn9
M21	b4	RYnA
M22	b5	RYnB
M23	Extended display flag	
M24	Extended setting flag	
M25	Work area	
M26	Control RUN/STOP transfer	
M27	Set data transfer	
M28	Work 1	
M29	Work 2	
M30	Unused	
M31	Work area	
M32	Work area	
M33	Work area	

Continued on the next page.

Continued from the previous page.

[Internal relays (M)]

Number	Details		
M34	Work area		RY(n+7)3
M35	Work area		RY(n+7)4
M36	Work area		RY(n+7)5
M37	Work area		RY(n+7)6
M38	Work area		RY(n+7)7
M39	Initialize data processing completion flag		RY(n+7)8
M40	Initialize data setting request flag		RY(n+7)9
M41	Error reset request flag		RY(n+7)A
M42	Work area		RY(n+7)B
M43	Work area		RY(n+7)C
M44	Work area		RY(n+7)D
M45	Work area		RY(n+7)E
M46	Work area		RY(n+7)F
M47	Unused		
M48			
M49			
M50			
M51	CH1	First alarm status	RXn0
M52	CH1	Second alarm status	RXn1
M53	CH1	Burnout alarm status	RXn2
M54	CH1	Heater break alarm (HBA) status	RXn3
M55	CH1	PID/AT transfer status	RXn4
M56	CH2	First alarm status	RXn5
M57	CH2	Second alarm status	RXn6
M58	CH2	Burnout alarm status	RXn7
M59	CH2	Heater break alarm (HBA) status	RXn8
M60	CH2	PID/AT transfer status	RXn9
M61	Work area		RXnA
M62	Work area		RXnB
M63	Extended display completion		RXnC
M64	Extended setting completion		RXnD
M65	Work area		RXnE
M66	Hardware error flag		RXnF
M67	Unused		
M68			
M69			
M70			

Continued on the next page.

Continued from the previous page.

[Internal relays (M)]

Number	Details	
M71	Work area	RX(n+7)0
M72	Work area	RX(n+7)1
M73	Work area	RX(n+7)2
M74	Work area	RX(n+7)3
M75	Work area	RX(n+7)4
M76	Work area	RX(n+7)5
M77	Work area	RX(n+7)6
M78	Work area	RX(n+7)7
M79	Initialize data processing request flag	RX(n+7)8
M80	Initialize data setting completion flag	RX(n+7)9
M81	Error status flag	RX(n+7)A
M82	Remote ready	RX(n+7)B
M83	Work area	RX(n+7)C
M84	Work area	RX(n+7)D
M85	Work area	RX(n+7)E
M86	Work area	RX(n+7)F
M87	Unused	
M88		
M89		
M90		

■ List of data registers (D)

Number	Details	
D1	Initialize	
D2		
D3		
D4		
D5		
D6		
D7		
D8		
D9		
D10		
D11		
D12		
D13	Unused	
D14		
D15		
D16		
D17		
D18		
D19	Extension No.	
D20	Extension No.	
D21	CH1	Temperature measured value (PV)
D22	CH2	Temperature measured value (PV)
D23	CH3	Temperature measured value (PV)
D24	CH4	Temperature measured value (PV)
D25	CH5	Temperature measured value (PV)
D26	CH6	Temperature measured value (PV)
D27	CH7	Temperature measured value (PV)
D28	CH8	Temperature measured value (PV)
D29	CH9	Temperature measured value (PV)
D30	CH10	Temperature measured value (PV)
D31	CH11	Temperature measured value (PV)
D32	CH12	Temperature measured value (PV)
D33	CH13	Temperature measured value (PV)
D34	CH14	Temperature measured value (PV)
D35	CH15	Temperature measured value (PV)
D36	CH16	Temperature measured value (PV)
D37	Unused	

Continued on the next page.

Continued from the previous page.

[Data registers (D)]

Number	Details	
D38	Unused	
D39		
D40		
D41	CH1	Temperature set value (SV)
D42	CH2	Temperature set value (SV)
D43	CH3	Temperature set value (SV)
D44	CH4	Temperature set value (SV)
D45	CH5	Temperature set value (SV)
D46	CH6	Temperature set value (SV)
D47	CH7	Temperature set value (SV)
D48	CH8	Temperature set value (SV)
D49	CH9	Temperature set value (SV)
D50	CH10	Temperature set value (SV)
D51	CH11	Temperature set value (SV)
D52	CH12	Temperature set value (SV)
D53	CH13	Temperature set value (SV)
D54	CH14	Temperature set value (SV)
D55	CH15	Temperature set value (SV)
D56	CH16	Temperature set value (SV)
D57	CH1	Set value change area
D58	CH2	Set value change area
D59	CH3	Set value change area
D60	CH4	Set value change area
D61	CH5	Set value change area
D62	CH6	Set value change area
D63	CH7	Set value change area
D64	CH8	Set value change area
D65	CH9	Set value change area
D66	CH10	Set value change area
D67	CH11	Set value change area
D68	CH12	Set value change area
D69	CH13	Set value change area
D70	CH14	Set value change area
D71	CH15	Set value change area
D72	CH16	Set value change area
D73 to D99	Unused	

7.2 Example of Initialize Sequence Program

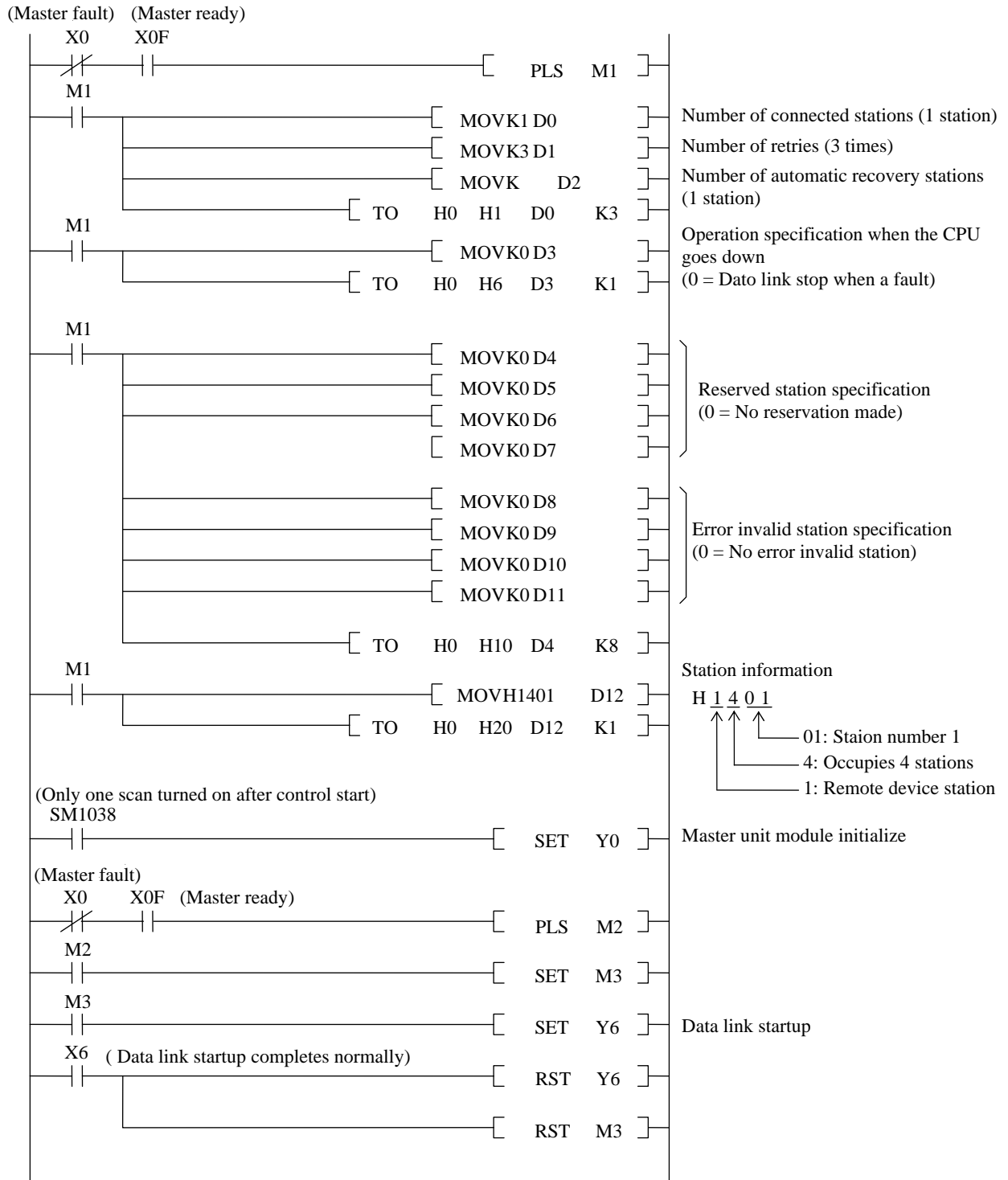

7.3 Example of Data Fetch Sequence Program

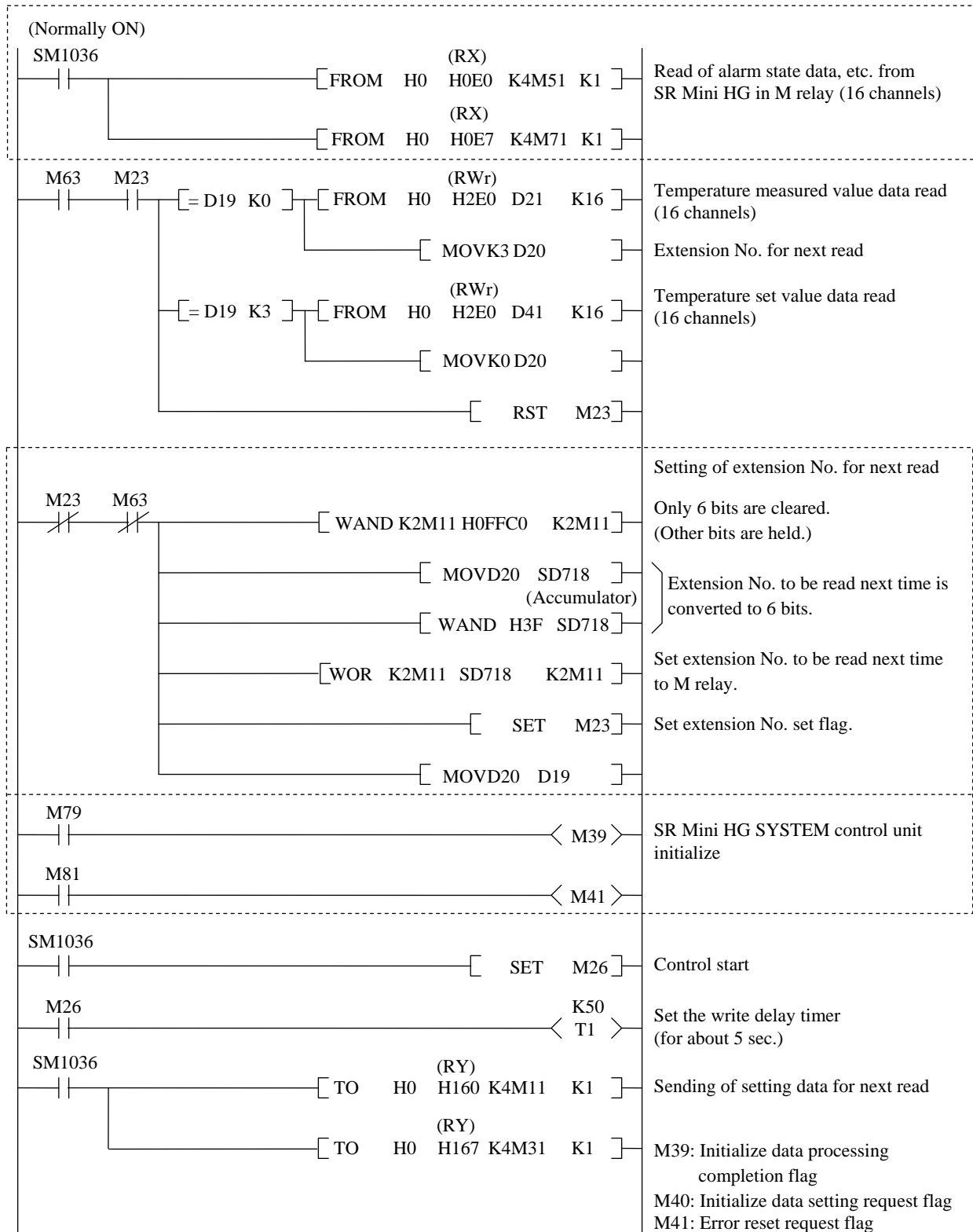

7.4 Example of Set Data Change Sequence Program

M64: Extended setting completion
 M24: Extended setting flag
 M27: Set data transfer

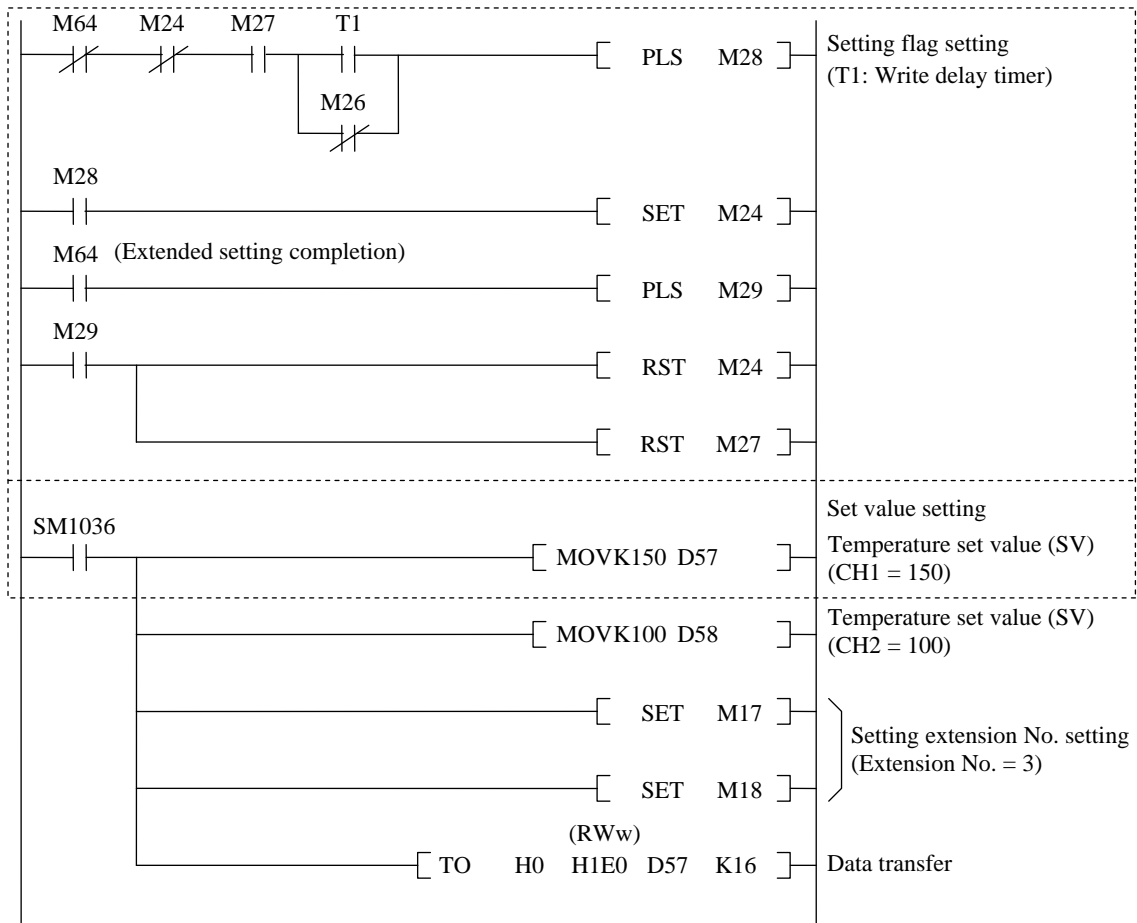

If M27 (Set data transfer) is turned on, the set data is written in the H-LNK-A module.



When the control STOP state is changed to the control RUN state, set the setting flag after a delay time of about 5 seconds by using a timer for initialize processing in the temperature control unit.

8. HOST COMMUNICATION

This Chapter describes communication identifiers to be added when communication is conducted by connecting the SR Mini HG SYSTEM control unit with the host computer.

■ Communications Quick Manual (IMS01V02-E□)

Location of addition:

Between identifiers **L1** and **Q3** in **6. COMMUNICATION IDENTIFIERS LIST**.

Details of addition:

Name	Identifiers	Digits	Attribute	Data range	Factory set value
Control & Communication Link, Selecting flag	C2	1	RO	0: Selecting not provided 1: Selecting provided	—

(Attributes RO: Read only)

Description of function:

Read-only identifier which indicates the presence or absence of selecting from the H-LNK-A module.

If there is selecting from the H-LNK-A module, set to “1.”

If polling is performed at this time and it ends normally, automatically returns to “0.”

Polling example

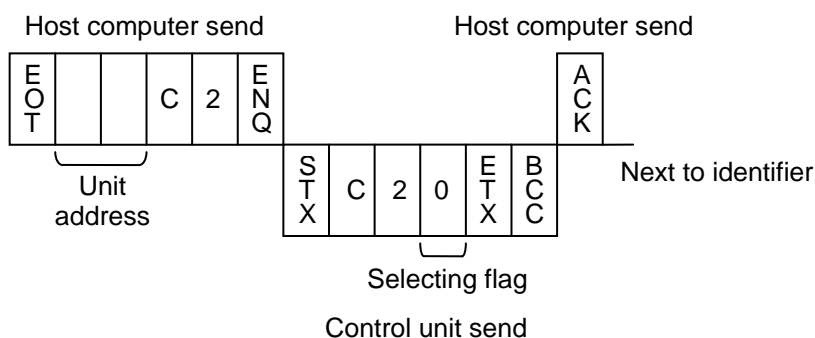

■ Supplementary Information, Initialize setting (Extended communications) (IMSRM07-E□)

Location of addition:

After identifier VS in ■ List of communication identifiers of INITIALIZE IDENTIFIERS FUNCTION EXPLANATION.

Details of addition:

Name	Identifiers	Digits	Attribute	Data range	Factory set value
Control & Communication Link , Selecting of No. of occupied channels	ZC	1	R/W	0: 16 channels 1: 8 channels	0

(Attributes R/W: Read and Write)

Description of function:

Identifier which defines the remote register channel specification (No. of channels occupied in **Control & Communication Link**).

Polling example

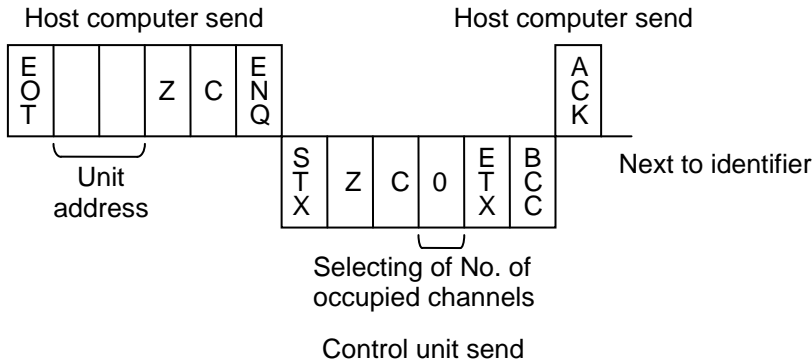

Selecting example

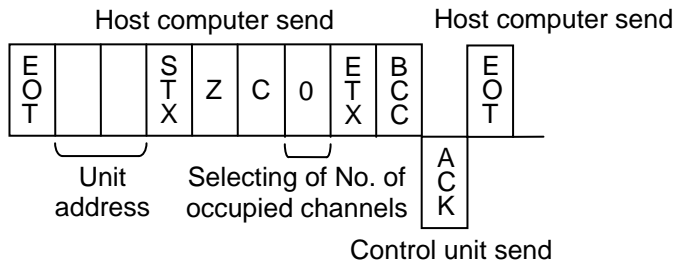

If you need the **Supplementary Information, Initialize setting [Extended communications] (IMSRM07-E□)**, please contact your RKC agent or our sales office.

■ List of remote register (4 stations occupied, Temperature control 8 channels)

If “1: 8 Channels” is selected by the number of **Control & Communication Link** occupying channels (ZC), the content of the remote register becomes as follows.

For details on the remote register when “0: 16 channels” is not changed prior to factor shipment, see **6.3 Remote Registers (P. 43)**.



“n” and “m” in the table are the addresses assigned to the master station by the station No. setting. They can be calculated by the following equations:

$$n = (\text{Station No.} - 1) \times 4 \quad m = (\text{Station No.} - 1) \times 4$$

As the calculation results are expressed in decimal digits, they are converted to hexadecimal digits before substituted for “n” and “m” in the table.

Example: If the station No. of the H-LNK-A module is “1” or “5”

For station No. 1: Remote register RWrn to RWrn+F → RWr0 to RWrF
RWwm to RWwm+F → RWw0 to RWwF

For station No. 5: Remote register RWrn to RWrn+F → RWr10 to RWr1F
RWwm to RWwm+F → RWw10 to RWw1F

Direction: Remote device station (Temperature control unit) → Master station (PLC) [RWr]

Address	Details	
RWrn	CH1	Temperature measured value (PV)
RWrn+1	CH2	Temperature measured value (PV)
RWrn+2	CH3	Temperature measured value (PV)
RWrn+3	CH4	Temperature measured value (PV)
RWrn+4	CH5	Temperature measured value (PV)
RWrn+5	CH6	Temperature measured value (PV)
RWrn+6	CH7	Temperature measured value (PV)
RWrn+7	CH8	Temperature measured value (PV)
RWrn+8	CH1	Data specified by the Extension No. setting for display [RYn0 to RYn5] * For details of the Extension No. and data, see 6.4 Extension No. (P. 45) .
RWrn+9	CH2	
RWrn+A	CH3	
RWrn+B	CH4	
RWrn+C	CH5	
RWrn+D	CH6	
RWrn+E	CH7	
RWrn+F	CH8	

For details, see page 66.

Direction: Master station (PLC) → Remote device station (Temperature control unit) [RWw]

Address	Details	
RWwm	CH1	Temperature set value (SV)
RWwm+1	CH2	Temperature set value (SV)
RWwm+2	CH3	Temperature set value (SV)
RWwm+3	CH4	Temperature set value (SV)
RWwm+4	CH5	Temperature set value (SV)
RWwm+5	CH6	Temperature set value (SV)
RWwm+6	CH7	Temperature set value (SV)
RWwm+7	CH8	Temperature set value (SV)
RWwm+8	CH1	Data specified by the Extension No. setting for setting [RYn6 to RYnB] * For details of the Extension No. and data, see 6.4 Extension No. (P. 45) . If Extension No. 3 [Temperature set value (SV)] is specified, data on RWwm+8 to RWwm+F is ignored.
RWwm+9	CH2	
RWwm+A	CH3	
RWwm+B	CH4	
RWwm+C	CH5	
RWwm+D	CH6	
RWwm+E	CH7	
RWwm+F	CH8	

* Data on the Extension No. specified by the remote output [RYn0 to RYn5 or RYn6 to RYnB] is processed.

Example: When Extension No. for display is set to “1” or Extension No. for setting is set to “9.”

Extension No. for display: Set to “1”

RYn5	RYn4	RYn3	RYn2	RYn1	RYn0
OFF	OFF	OFF	OFF	OFF	ON

→ **Extension No. 1:
Manipulated output
(Heat-side)**

Remote registers [RWrn+8 to RWrn+F] become the Manipulated output (Heat-side) of CH1 to CH8.

Extension No. for setting: Set to “9”

RYnB	RYnA	RYn9	RYn8	RYn7	RYn6
OFF	OFF	ON	OFF	OFF	ON

→ **Extension No. 9:
1st alarm set value**

Remote registers [RWwm+8 to RWwm+F] become the 1st alarm set values of CH1 to CH8.

 For details of the remote output [RYn0 to RYn5 or RYn6 to RYnB], see **6.2 Remote Input/Output (P. 33)**.



Unused channels become as follows.

Remote registers, RWrn to RWrn+F → “0” is displayed.

Remote registers, RWwm to RWwm+F → Set data is ignored.



RKC INSTRUMENT INC.

HEADQUARTERS: 16-6, KUGAHARA 5-CHOME, OHTA-KU TOKYO 146-8515 JAPAN

PHONE: 03-3751-9799 (+81 3 3751 9799)

FAX: 03-3751-8585 (+81 3 3751 8585)

E-mail: info@rkcinst.co.jp

Website: <http://www.rkcinst.com/>

