Pressure Indicator

PG500

***Communication
Instruction Manual***

- Modbus is a registered trademark of Schneider Electric.
- Company names and product names used in this manual are the trademarks or registered trademarks of the respective companies.

Thank you for purchasing this RKC product. In order to achieve maximum performance and ensure proper operation of your new instrument, carefully read all the instructions in this manual. Please place the manual in a convenient location for easy reference.

SYMBOLS

WARNING : This mark indicates precautions that must be taken if there is danger of electric shock, fire, etc., which could result in loss of life or injury.

CAUTION : This mark indicates that if these precautions and operating procedures are not taken, damage to the instrument may result.



: This mark indicates that all precautions should be taken for safe usage.



: This mark indicates important information on installation, handling and operating procedures.



: This mark indicates supplemental information on installation, handling and operating procedures.



: This mark indicates where additional information may be located.



WARNING

- An external protection device must be installed if failure of this instrument could result in damage to the instrument, equipment or injury to personnel.
- All wiring must be completed before power is turned on to prevent electric shock, fire or damage to instrument and equipment.
- This instrument must be used in accordance with the specifications to prevent fire or damage to instrument and equipment.
- This instrument is not intended for use in locations subject to flammable or explosive gases.
- Do not touch high-voltage connections such as power supply terminals, etc. to avoid electric shock.
- RKC is not responsible if this instrument is repaired, modified or disassembled by other than factory-approved personnel. Malfunction can occur and warranty is void under these conditions.

CAUTION

- This product is intended for use with industrial machines, test and measuring equipment. (It is not designed for use with medical equipment and nuclear energy.)
- This is a Class A instrument. In a domestic environment, this instrument may cause radio interference, in which case the user may be required to take additional measures.
- This instrument is protected from electric shock by reinforced insulation. Provide reinforced insulation between the wire for the input signal and the wires for instrument power supply, source of power and loads.
- Be sure to provide an appropriate surge control circuit respectively for the following:
 - If input/output or signal lines within the building are longer than 30 meters.
 - If input/output or signal lines leave the building, regardless the length.
- This instrument is designed for installation in an enclosed instrumentation panel. All high-voltage connections such as power supply terminals must be enclosed in the instrumentation panel to avoid electric shock by operating personnel.
- All precautions described in this manual should be taken to avoid damage to the instrument or equipment.
- All wiring must be in accordance with local codes and regulations.
- All wiring must be completed before power is turned on to prevent electric shock, instrument failure, or incorrect action.

The power must be turned off before repairing work for input break and output failure including replacement of sensor, contactor or SSR, and all wiring must be completed before power is turned on again.
- To prevent instrument damage or failure, protect the power line and the input/output lines from high currents with a protection device such as fuse, circuit breaker, etc.
- Prevent metal fragments or lead wire scraps from falling inside instrument case to avoid electric shock, fire or malfunction.
- Tighten each terminal screw to the specified torque found in the manual to avoid electric shock, fire or malfunction.
- For proper operation of this instrument, provide adequate ventilation for heat dispensation.
- Do not connect wires to unused terminals as this will interfere with proper operation of the instrument.
- Turn off the power supply before cleaning the instrument.
- Do not use a volatile solvent such as paint thinner to clean the instrument. Deformation or discoloration will occur. Use a soft, dry cloth to remove stains from the instrument.
- To avoid damage to instrument display, do not rub with an abrasive material or push front panel with a hard object.

NOTICE

- This manual assumes that the reader has a fundamental knowledge of the principles of electricity, process control, computer technology and communications.
- The figures, diagrams and numeric values used in this manual are only for purpose of illustration.
- RKC is not responsible for any damage or injury that is caused as a result of using this instrument, instrument failure or indirect damage.
- RKC is not responsible for any damage and/or injury resulting from the use of instruments made by imitating this instrument.
- Periodic maintenance is required for safe and proper operation of this instrument. Some components have a limited service life, or characteristics that change over time.
- Every effort has been made to ensure accuracy of all information contained herein. RKC makes no warranty expressed or implied, with respect to the accuracy of the information. The information in this manual is subject to change without prior notice.
- No portion of this document may be reprinted, modified, copied, transmitted, digitized, stored, processed or retrieved through any mechanical, electronic, optical or other means without prior written approval from RKC.

CONTENTS

	Page
1. OUTLINE.....	1
2. HOST COMMUNICATION	2
2.1 Host Communication Specifications	2
■ RKC communication.....	2
■ Modbus	3
2.2 Wiring for Host Communication	4
2.2.1 Connection to the RS-485 port of PG500.....	4
■ Communication terminal number and signal details (RS-485).....	4
■ Connection to the RS-485 port of the host computer (master).....	4
■ Connection to the RS-232C port of the host computer (master).....	5
■ Connection to the USB of the host computer (master).....	6
2.2.2 Connection to the RS-422A port of PG500	7
■ Communication terminal number and signal details (RS-422A).....	7
■ Connection to the RS-422A port of the host computer (master).....	7
■ Connection to the RS-232C port of the host computer (master).....	8
■ Connection to the USB of the host computer (master).....	9
2.3 Setting	10
2.3.1 Display sequence.....	10
2.3.2 Description of each parameter	11
■ Function block 60 (F60.) [Engineering mode].....	11
■ Setup setting mode	11
2.3.3 Setting Procedure Example	12
2.4 Communication Requirements	16
■ Processing times during data send/receive.....	16
■ RS-485 (2-wire system) send/receive timing (RKC communication).....	17
■ Fail-safe.....	17
3. RKC COMMUNICATION PROTOCOL.....	18
3.1 Polling.....	18
3.1.1 Polling procedures	19
3.1.2 Polling procedure example (When the host computer requests data).....	22
■ Normal transmission.....	22
■ Error transmission	23
3.2 Selecting.....	24
3.2.1 Selecting procedures	24
3.2.2 Selecting procedure example (When the host computer sends the set values).....	27
■ Normal transmission.....	27
■ Error transmission	27
4. MODBUS COMMUNICATION PROTOCOL.....	28
4.1 Message Format.....	28
■ Slave address.....	28
■ Function code.....	28
■ Data.....	28
■ Error check.....	28

	Page
4.2 Function Code	29
4.3 Communication Mode.....	29
4.4 Slave Responses.....	30
4.5 Calculating CRC-16.....	31
■ The flow chart of CRC-16.....	32
■ Example of a CRC calculation in the 'C' language	33
4.6 Register Read and Write	34
4.6.1 Read holding registers [03H].....	34
4.6.2 Preset single register [06H].....	35
4.6.3 Diagnostics (Loopback test) [08H]	36
4.6.4 Preset multiple registers [10H].....	37
4.7 Caution for Handling Communication Data	38
4.8 How to Use Modbus Data Mapping.....	39
4.9 Modbus Data Mapping Address	40
■ Register address for data mapping	40
■ Register address for data read/writes.....	41
5. COMMUNICATION DATA LIST	42
5.1 Reference to Communication Data List.....	42
5.2 Communication Data List (RKC communication/Modbus).....	44
■ Gain setting and linearizing type (Only our pressure sensor CZ-100P/CZ-200P)	53
5.3 The communication data which will be initialized or changed, if the communication data are changed.....	54
■ The communication data which will be initialized if the Input type is changed	54
■ The communication data which will be initialized if the Display unit is changed.....	55
■ The communication data which will be initialized if the Alarm type is changed	56
■ The communication data which will be automatically converted if the Input decimal point position is changed.....	57
■ The communication data which will be automatically converted if the Gain setting decimal point position is changed.....	57
■ The communication data which will be automatically converted if the Pressure display high/low are changed	58
6. TROUBLESHOOTING	59
■ RKC communication.....	59
■ Modbus	60
7. ASCII 7-BIT CODE TABLE	61

1. OUTLINE

■ RKC communication and Modbus

The communication function makes it possible to monitor and set the data of the Pressure Indicator PG500 from a computer. The PG500 interfaces with the host computer via Modbus or RKC communication (ANSI X3.28-1976 subcategories 2.5 and A4) protocols. The communication interface used for both protocols is RS-485 or RS-422A. The host communication function (RS-485 or RS-422A) is available only if the communication function is specified at the time of ordering.

In case of Modbus protocol, frequently used communication data can be grouped into a specified memory address area for faster communication. This is called “Data mapping function.”

For reference purposes, the Modbus protocol identifies the host computer as master, the PG500 as slave. One host computer (master) can communicate with up to 31 indicators.

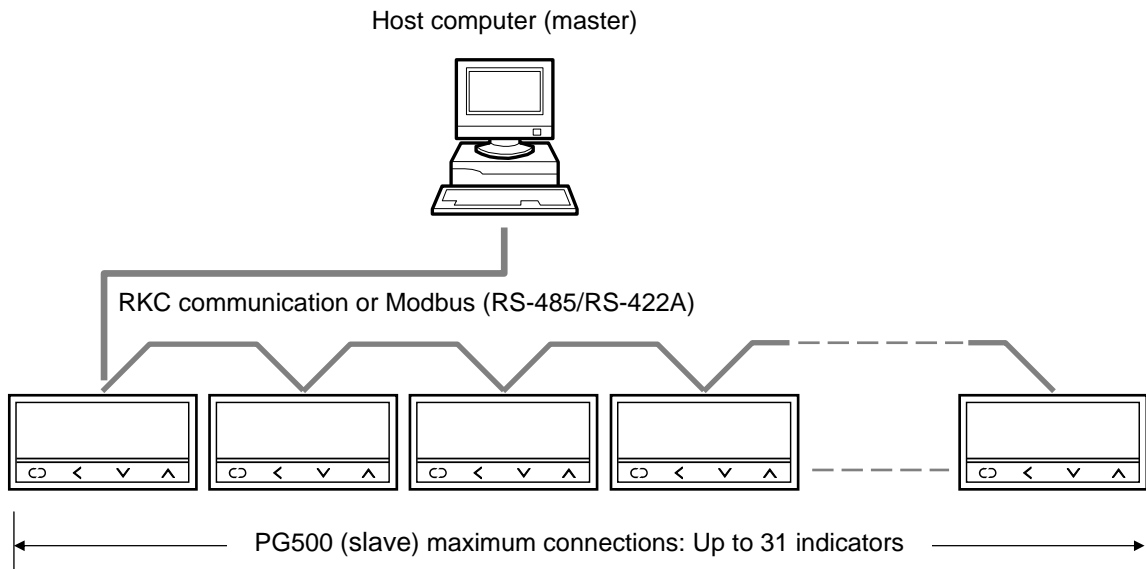

2. HOST COMMUNICATION

2.1 Host Communication Specifications

■ RKC communication

- Interface:** Based on RS-485, EIA standard
Based on RS-422A, EIA standard
- Connection method:** RS-485: 2-wire system, half-duplex multi-drop connection
RS-422A: 4-wire system, half-duplex multi-drop connection
- Synchronous method:** Start-stop synchronous type
- Communication speed:** 1200 bps, 2400 bps, 4800 bps, 9600 bps, 19200 bps, 38400 bps
- Data bit configuration:** Start bit: 1
Data bit: 7 or 8
Parity bit: Without, Odd or Even
Stop bit: 1 or 2
- Protocol:** ANSI X3.28-1976 subcategories 2.5 and A4
RKC communication protocol
Polling/Selecting type
- Error control:** Vertical parity (With parity bit selected)
Horizontal parity (BCC check)
- Communication code:** ASCII 7-bit code
- Termination resistor:** Externally terminal connected (Example: 120 Ω 1/2 W)
- Xon/Xoff control:** None
- Maximum connections:** Up to 31 indicators
- Interval time:** 0 to 250 ms
- Signal logic:** RS-485, RS-422A

Signal voltage	Logic
$V(A) - V(B) \geq 2\text{ V}$	0 (SPACE)
$V(A) - V(B) \leq -2\text{ V}$	1 (MARK)

Voltage between V (A) and V (B) is the voltage of (A) terminal for the (B) terminal.

■ Modbus

Interface:	Based on RS-485, EIA standard Based on RS-422A, EIA standard
Connection method:	RS-485: 2-wire system, half-duplex multi-drop connection RS-422A: 4-wire system, half-duplex multi-drop connection
Synchronous method:	Start-stop synchronous type
Communication speed:	1200 bps, 2400 bps, 4800 bps, 9600 bps, 19200 bps, 38400 bps
Data bit configuration:	Start bit: 1 Data bit: 8 Parity bit: Without, Odd or Even Stop bit: 1 or 2
Protocol:	Modbus
Signal transmission mode:	Remote Terminal Unit (RTU) mode
Function code:	03H (Read holding registers) 06H (Preset single register) 08H (Diagnostics: loopback test) 10H (Preset multiple registers)
Error check method:	CRC-16
Error code:	1: Function code error 2: When the mismatched address is specified 3: When the specified number of data items in the query message exceeds the maximum number of data items available 4: Self-diagnostic error response
Termination resistor:	Externally terminal connected (Example: 120 Ω 1/2 W)
Maximum connections:	Up to 31 indicators
Interval time:	0 to 250 ms
Data interval extension time:	0 to 250 ms
Signal logic:	RS-485, RS-422A

Signal voltage	Logic
$V(A) - V(B) \geq 2\text{ V}$	0 (SPACE)
$V(A) - V(B) \leq -2\text{ V}$	1 (MARK)

Voltage between V (A) and V (B) is the voltage of (A) terminal for the (B) terminal.

Data mapping: When this communication method is used, 16 types of data (mapping data) can be specified as desired for the specified indicator, and read/write can be performed continuously.

2.2 Wiring for Host Communication



WARNING

To prevent electric shock or instrument failure, turn off the power before connecting or disconnecting the instrument and peripheral equipment.

2.2.1 Connection to the RS-485 port of PG500

■ Communication terminal number and signal details (RS-485)

Communication terminals

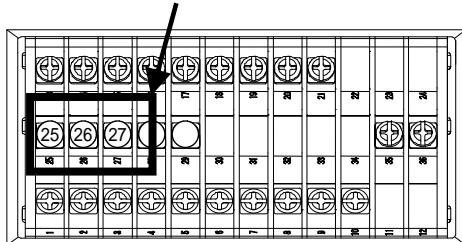

PG500 rear view

RS-485

Terminal No.	Signal name	Symbol
25	Signal ground	SG
26	Send/Receive data	T/R (A)
27	Send/Receive data	T/R (B)

■ Connection to the RS-485 port of the host computer (master)

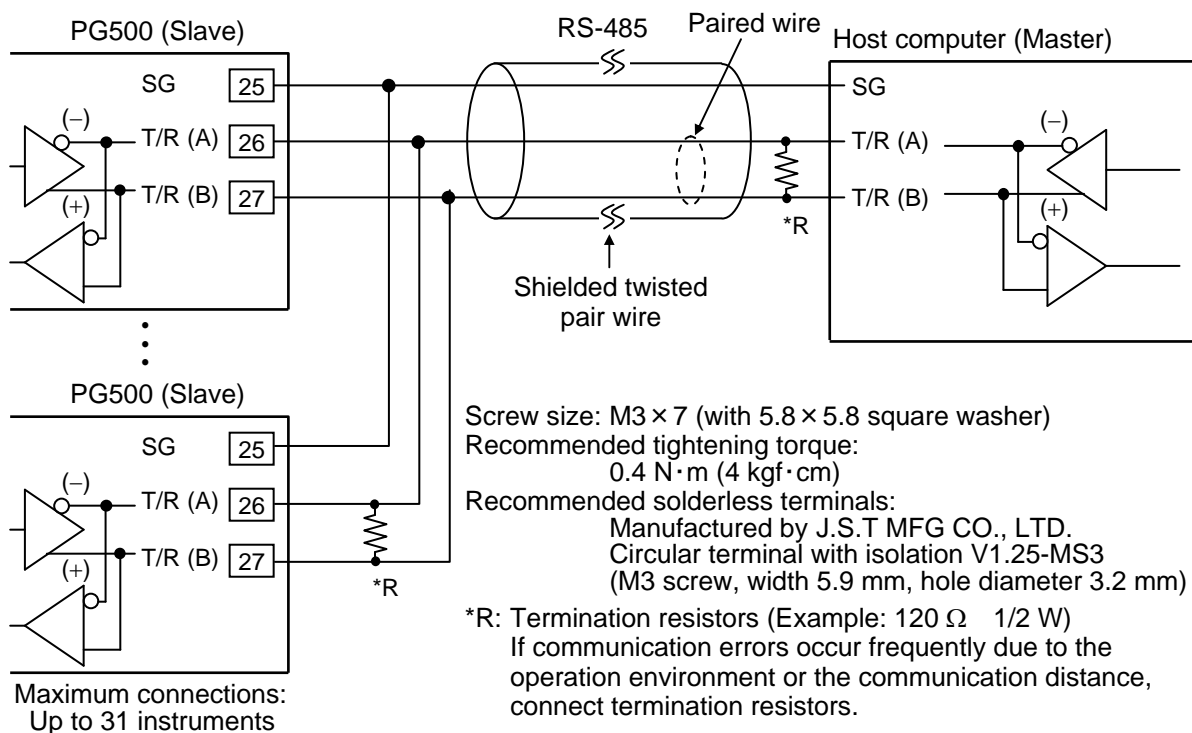

The cable and termination resistor (s) must be provided by the customer.

■ Connection to the RS-232C port of the host computer (master)

Use a RS-232C/RS-485 converter with an automatic send/receive transfer function.

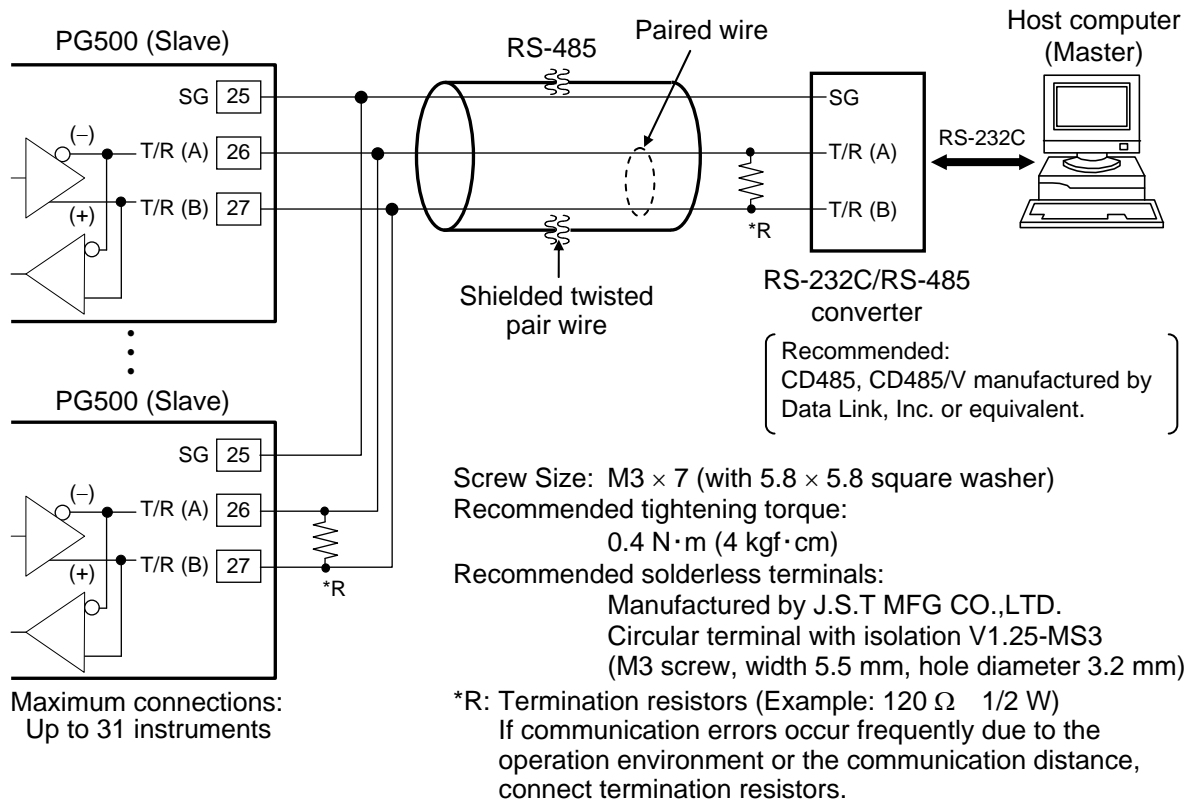

The cable and termination resistor (s) must be provided by the customer.

■ **Connection to the USB of the host computer (master)**

Connect the USB communication converter between the host computer and the PG500.

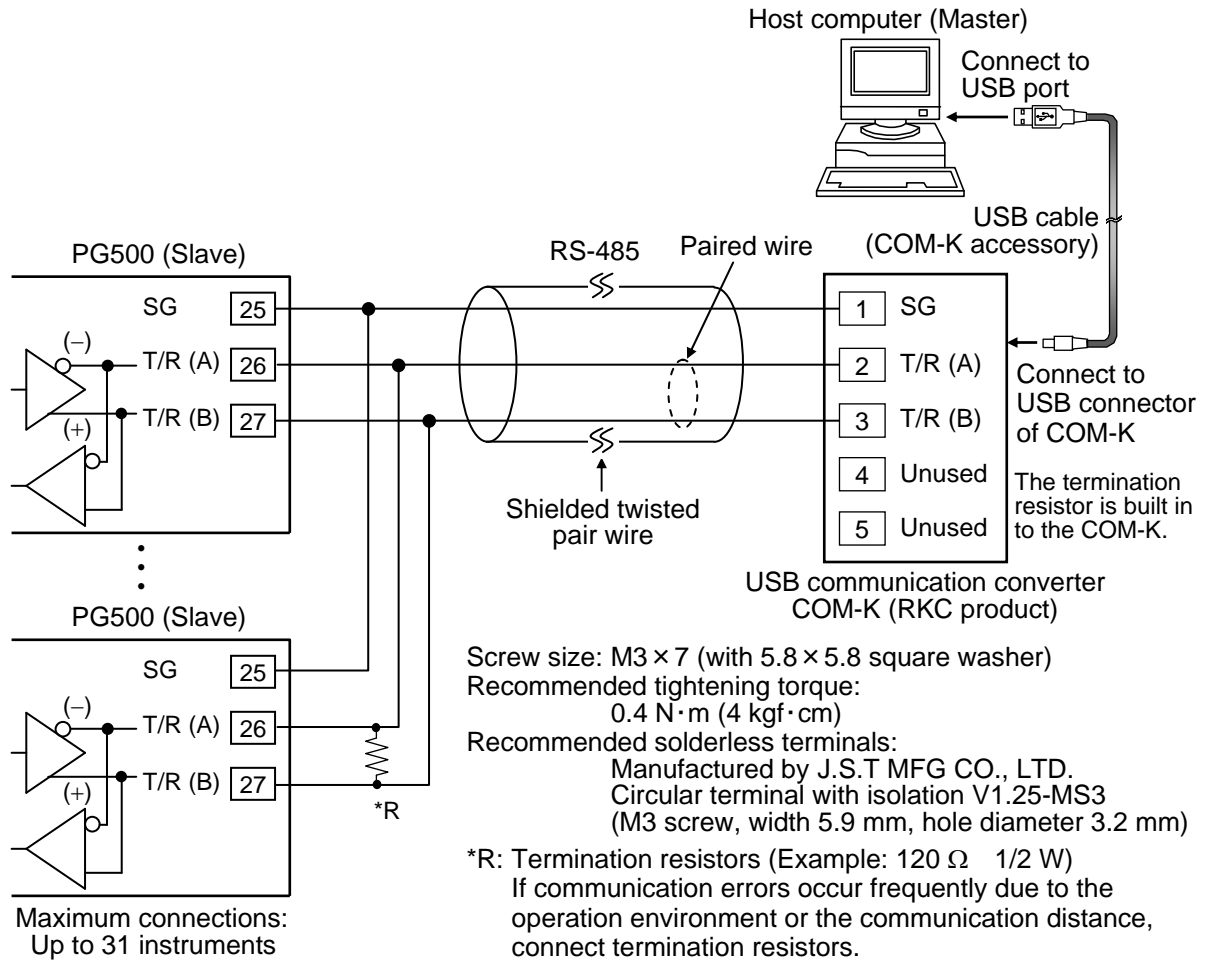

The cable and termination resistor (s) must be provided by the customer.

For the COM-K, refer to the **COM-K Instruction Manual (IMR01Z01-E□)**.

2.2.2 Connection to the RS-422A port of PG500

■ Communication terminal number and signal details (RS-422A)

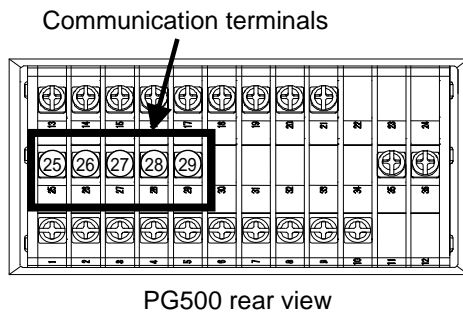

RS-485

Terminal No.	Signal name	Symbol
25	Signal ground	SG
26	Send data	T (A)
27	Send data	T (B)
28	Receive data	R (A)
29	Receive data	R (B)

■ Connection to the RS-422A port of the host computer (master)

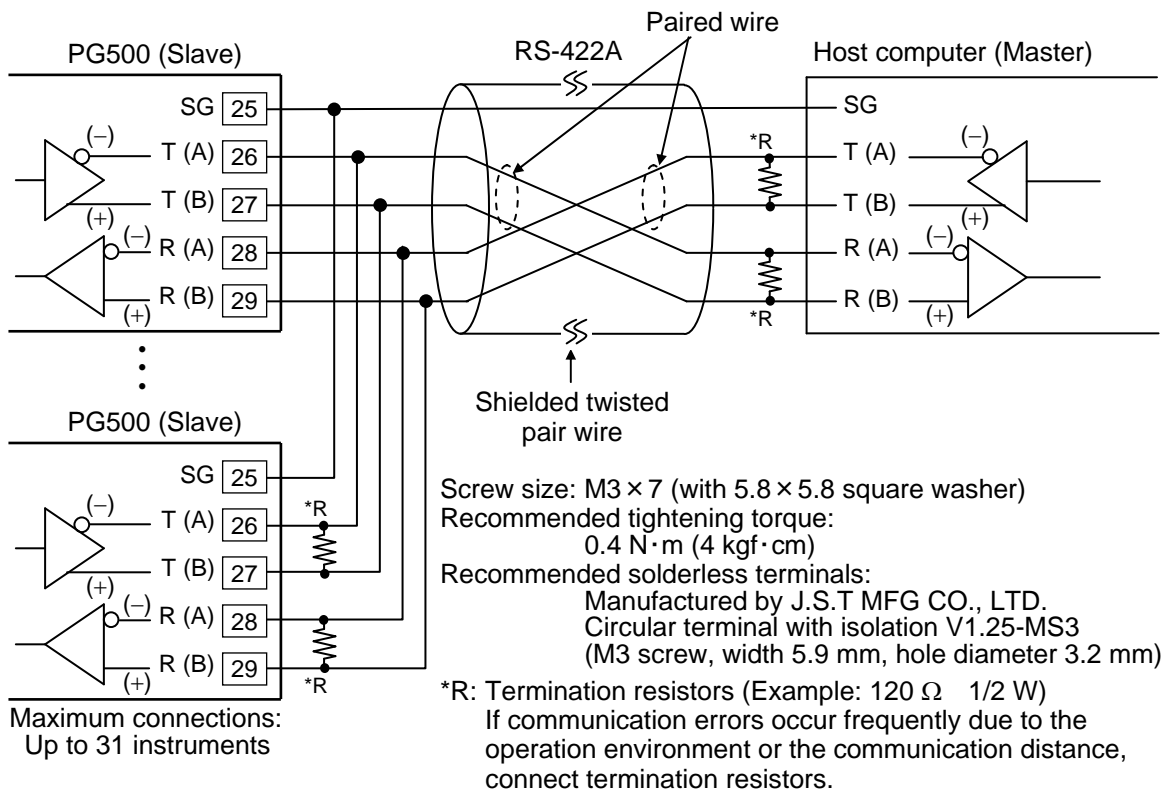

The cable and termination resistor (s) must be provided by the customer.

■ **Connection to the RS-232C port of the host computer (master)**

A RS-232C/RS-485 converter is required.

* Use D-SUB 25-pin modular conversion connector (Recommended type: TM12RV-64-H manufactured by HIROSE ELECTRIC CO., LTD.) when connector of host computer is D-SUB 25-pin.

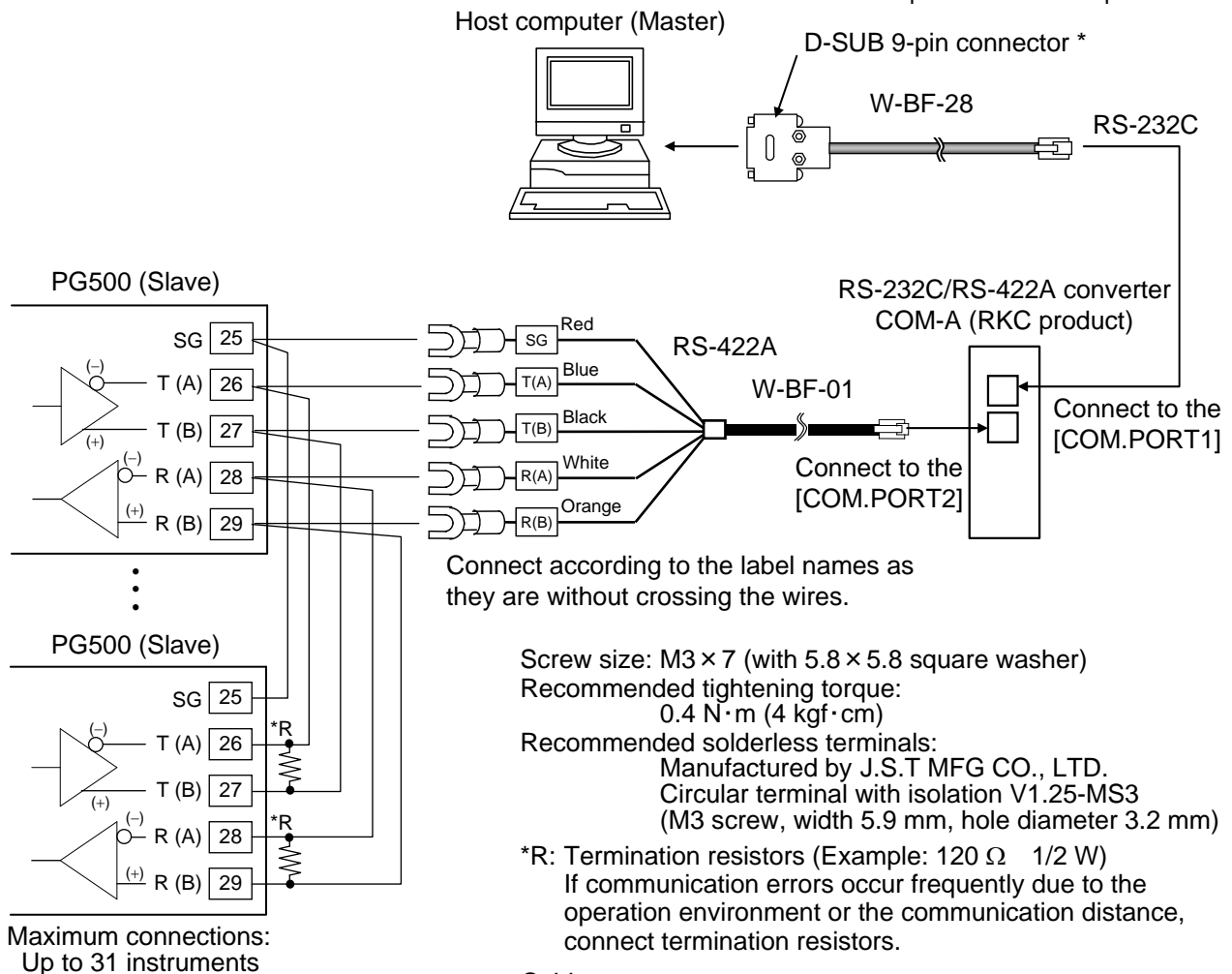

The cable and termination resistor (s) must be provided by the customer.



W-BF-01 or W-BF-28 communication cable (RKC product) can be used as communication cable (sold separately). If noise is a factor, customer should use a twisted pair cable (not included) or something to that effect.



Recommended RS-232C/RS-422A converter: **COM-A** (RKC product)
 For the COM-A, refer to the **COM-A/COM-B Instruction Manual (IMSRM33-E□)**.

■ Connection to the USB of the host computer (master)

Connect the USB communication converter between the host computer and the PG500.

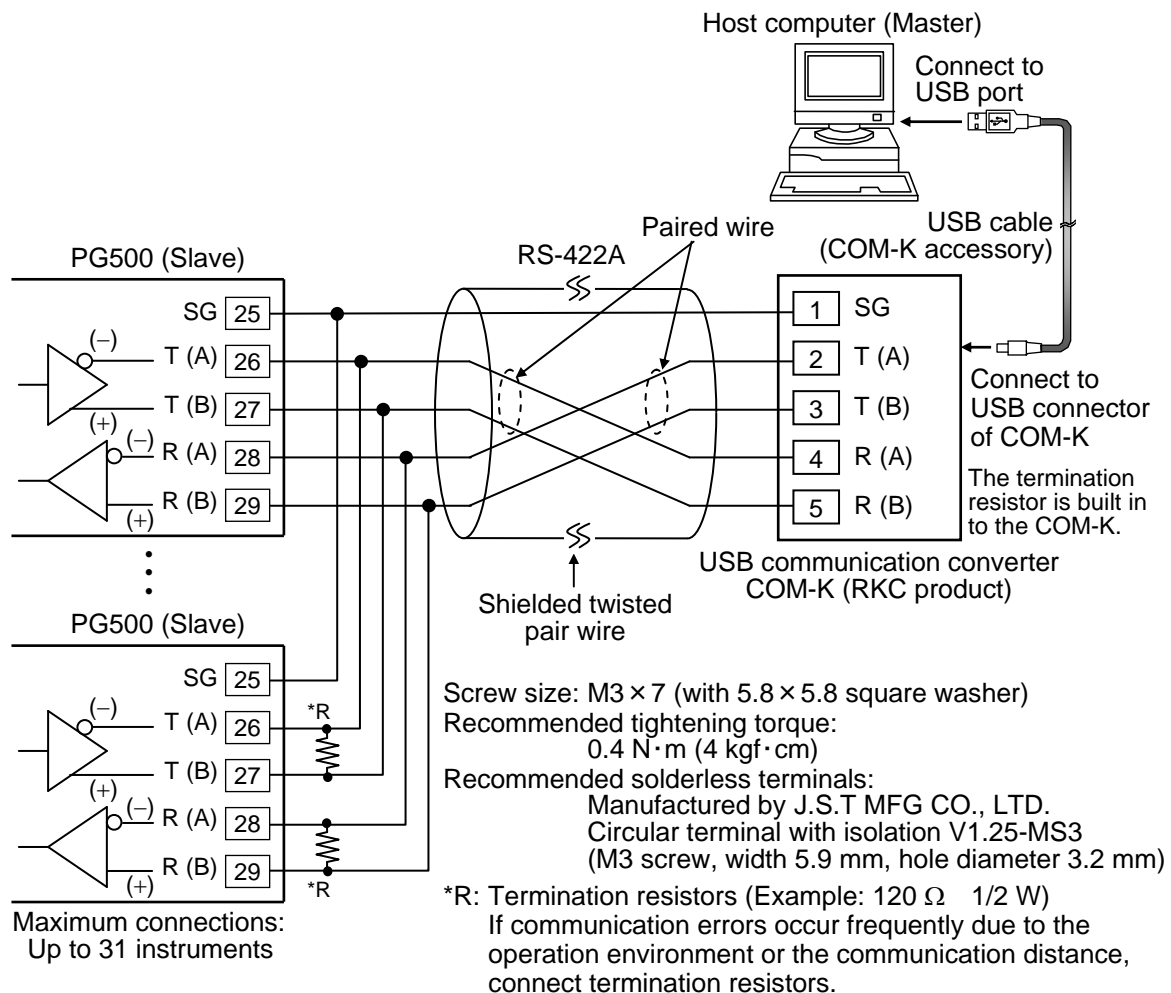

The cable and termination resistor (s) must be provided by the customer.

For the COM-K, refer to the **COM-K Instruction Manual (IMR01Z01-E□)**.

2.3 Setting

To establish communication parameters between host computer (master) and PG500 (slave), it is necessary to set the following parameters on each PG500 (slave) in the function block 60 (F60.) of engineering mode and setup setting mode.

2.3.1 Display sequence

: Parameter for communication

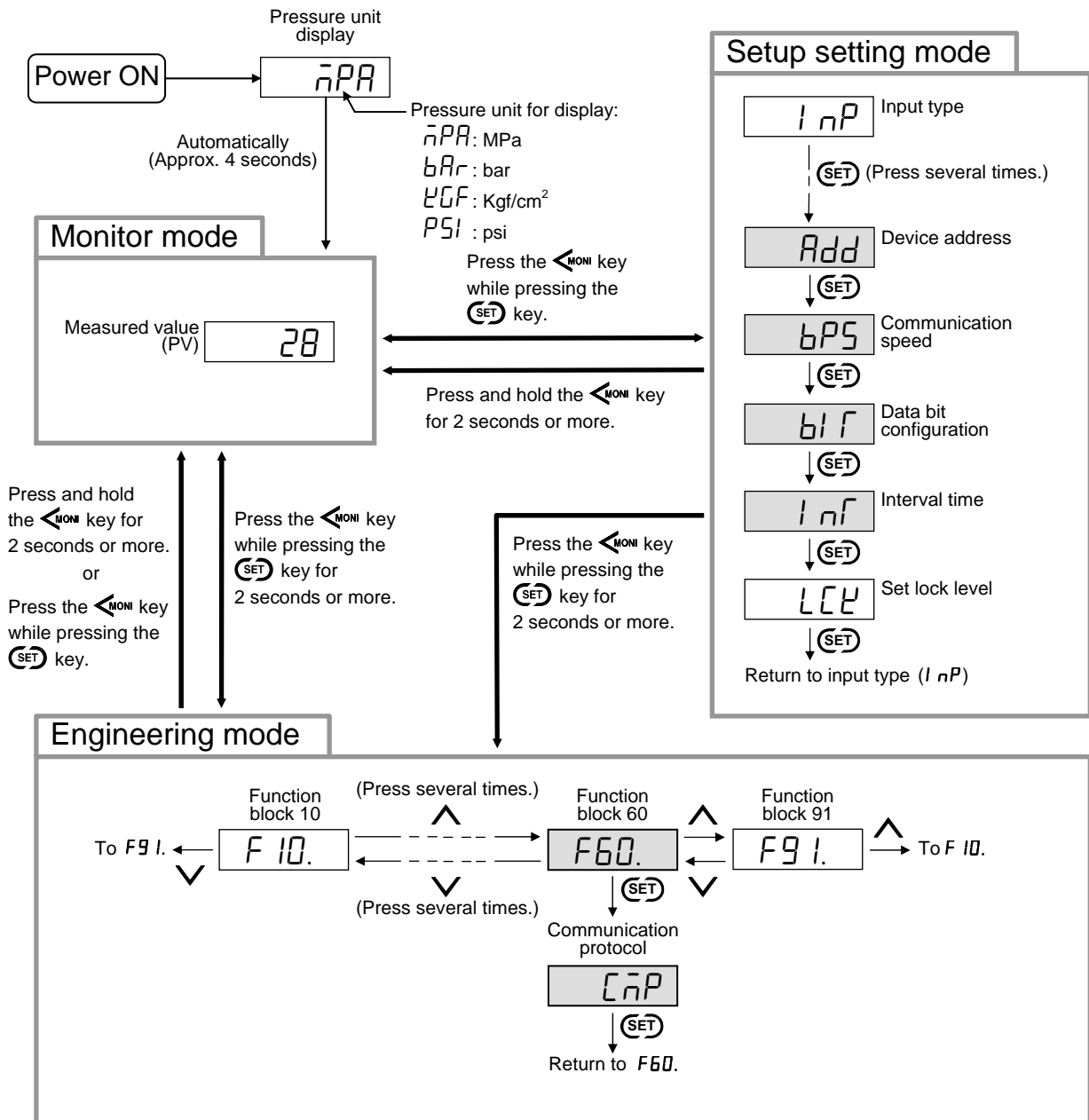

For the procedure for switching to mode and setting communication parameters, refer to **2.3.3 Setting Procedure Example (P. 12)**.

2.3.2 Description of each parameter

■ Function block 60 (F60.) [Engineering mode]

Symbol	Name	Data range	Description	Factory set value
F60. (F60)	Function block 60	This is the first parameter symbol of function block 60. This function block does not appear when there is no communication function.		
CMP (CMP)	Communication protocol	0: RKC communication 1: Modbus	Use to select a protocol of communication function.	0

■ Setup setting mode

Symbol	Name	Data range	Description	Factory set value
Add (Add)	Device address (Slave address)	0 to 99 Maximum connections: Up to 31 instruments	Do not use the same device address for more than one instrument in multi-drop connection. Each instrument must have a unique address in multi-drop connection. In Modbus communication, communication is not possible when the address is 0.	0
bPS (bPS)	Communication speed	1.2: 1200 bps 2.4: 2400 bps 4.8: 4800 bps 9.6: 9600 bps 19.2: 19200 bps 38.4: 38400 bps	Set the same communication speed for both the PG500 (slave) and the host computer (master).	9.6
l f (bIT)	Data bit configuration	Refer to Data bit configuration table .	Set the same data bit configuration for both the PG500 (slave) and the host computer (master).	8n1
l n f (InT)	Interval time	0 to 250 ms	The interval time for the PG500 should be set to provide a time for host computer to finish sending all data including stop bit and to switch the line to receive status for the host.	10

Data bit configuration table

Set value	Data bit	Parity bit	Stop bit	Settable communication
8n1	8	Without	1	RKC communication and Modbus
8n2	8	Without	2	
8E1	8	Even	1	
8E2	8	Even	2	
8o1	8	Odd	1	
8o2	8	Odd	2	

Set value	Data bit	Parity bit	Stop bit	Settable communication
7n1	7	Without	1	RKC communication
7n2	7	Without	2	
7E1	7	Even	1	
7E2	7	Even	2	
7o1	7	Odd	1	
7o2	7	Odd	2	



Interval time:

The interval time for the PG500 should be set to provide a time for host computer to finish sending all data including stop bit and to switch the line to receive status for the host. If the interval time between the two is too short, the PG500 may send data before the host computer is ready to receive it. In this case, communication transmission cannot be conducted correctly.

2.3.3 Setting Procedure Example

This example shows how to set the following values.

Communication protocol: RKC communication
 Device address: 0
 Communication speed: 38400 bps
 Data bit configuration: Data 8-bit, Parity bit without, Stop 1-bit
 Interval time: 50 ms



WARNING

Parameters in the Engineering mode (F10 to F91) should be set according to the application before setting any parameter related to operation.

Once the parameters in the Engineering mode are set correctly, no further changes need to be made to parameters for the same application under normal conditions.

If they are changed unnecessarily, it may result in malfunction or failure of the instrument.

RKC will not bear any responsibility for malfunction or failure as a result of improper changes in the Engineering mode.



When all communication parameter settings have been completed, turn the power off and then on to make the new set values take effect.



If you have locked the PG500 setting data so that it cannot be changed, the lock must be released before configuring the communication settings.



To release the lock, refer to **Set lock level (LLE)** of **PG500 Operation Manual (IMR02F02-E□)**.



Press the **(SET)** key to store the new value. If the **(SET)** key is not pressed within one minute, the display returns to the measured value (PV) monitor screen and the set value returns the previous setting.



For details on changing the numeric value, refer to **PG500 Operation Manual (IMR02F02-E□)**.

1. Turn on the power of the PG500.

2. Go to the Engineering mode.

Press the **MONI** key for 2 seconds or more while pressing the **SET** key at measured value (PV) monitor until Engineering mode is displayed.

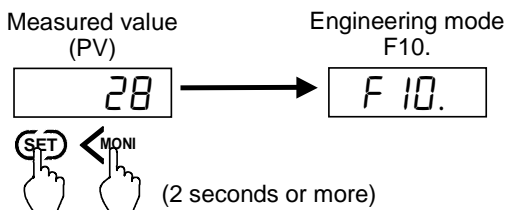

3. Go to the Function blocks 60 (F60.)

Press the **Y** key twice at function block 10 (F10.) until function block 60 (F60.) is displayed.

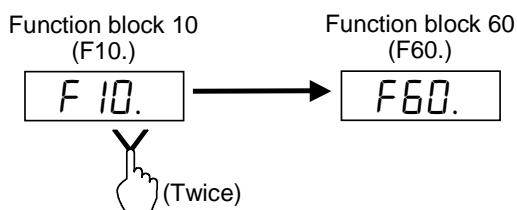

4. Set the Communication protocol.

Press the **SET** key at function block 60 (F60.) until communication protocol is displayed.

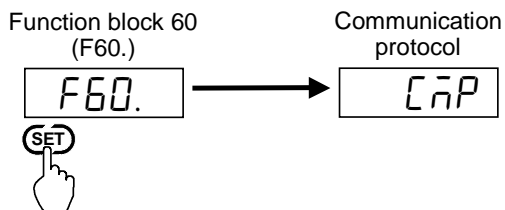

Press the **MONI** key to set the communication protocol.

Setting range: 0: RKC communication
1: Modbus

As an example, factory set value “0 (RKC communication)” is set.

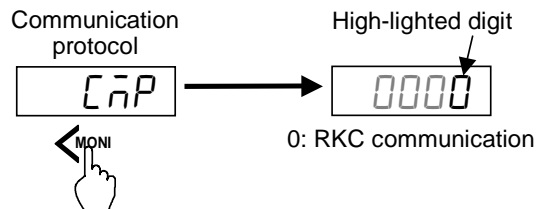

5. Go to the Measured value (PV).

Press and hold the **MONI** key for 2 seconds or more until measured value (PV) is displayed.

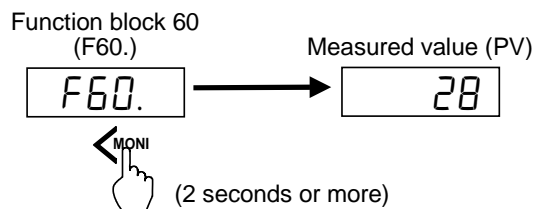

6. Go to the Setup setting mode.

Press the **MONI** key while pressing the **SET** key at measured value (PV) monitor until Setup setting mode is displayed.

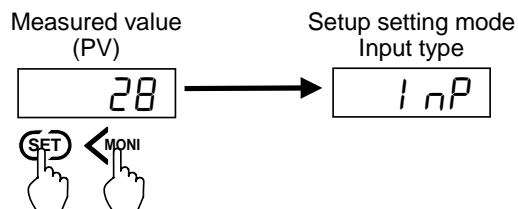

7. Set the Device address.

Press the **(SET)** key several times at input type until device address is displayed.

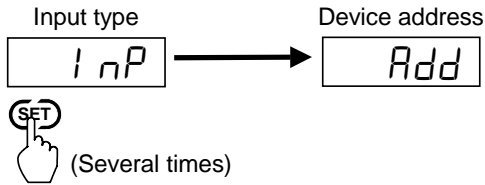

Press the **<MONI** key to set the device address.
 Setting range: 0 to 99 (RKC communication)
 1 to 99 (Modbus)

As an example, factory set value "0" is set.

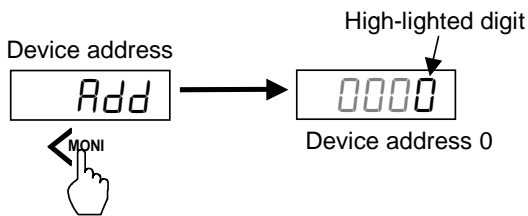

8. Set the Communication speed.

Press the **(SET)** key. The display goes to the communication speed.

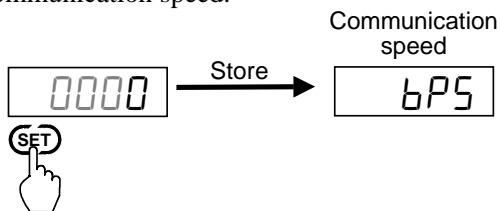

Press the **<MONI** key to set the communication speed.

- Setting range: 1.2: 1200 bps
- 2.4: 2400 bps
- 4.8: 4800 bps
- 9.6: 9600 bps
- 19.2: 19200 bps
- 38.4: 38400 bps

As an example, "38.4 (38400 bps)" is set.

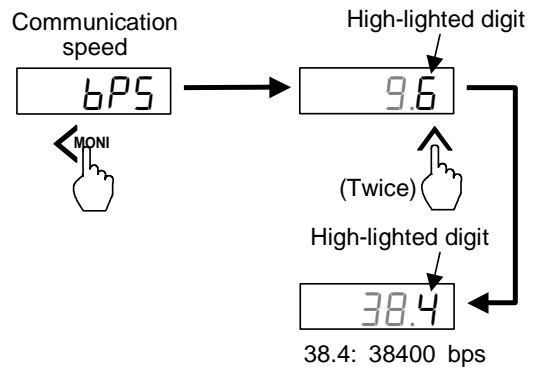

9. Set the Data bit configuration.

Press the **(SET)** key. The display goes to the data bit configuration.

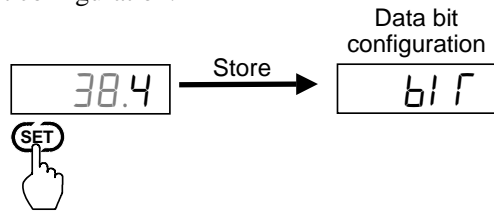

Press the **<MONI** key to set the data bit configuration.
 Setting range:

Refer to **Data bit configuration table (P. 11)**.

As an example, factory set value "8n1 (Data 8-bit, Parity bit without, Stop 1-bit)" is set.

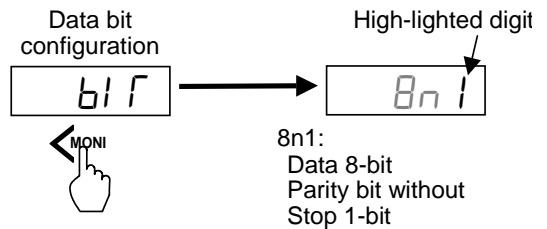

10. Set the Interval time.

Press the **SET** key. The display goes to the interval time.

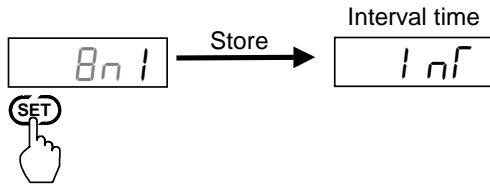

Press the **MONI** key to set the interval time.

Setting range: 0 to 250 ms

As an example "50" is set.

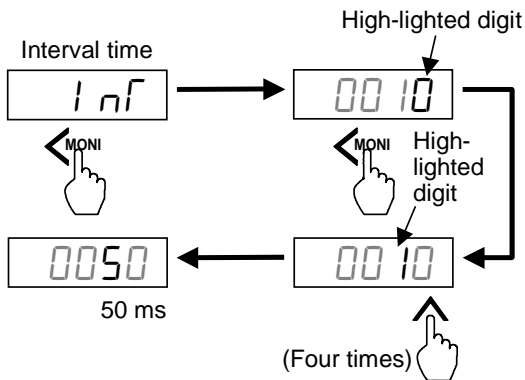

Press the **SET** key. The display goes to the set lock level.

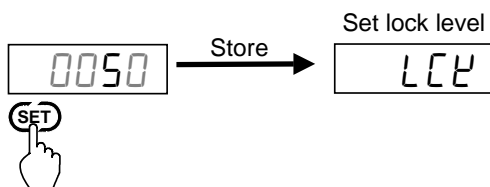

11. Go to the Measured value (PV).

Press and hold the **MONI** key for 2 seconds or more until measured value (PV) is displayed.

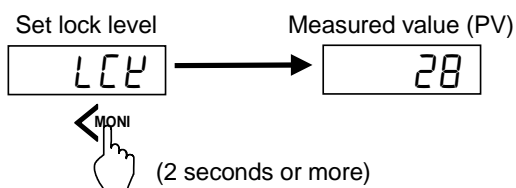

12. Enable communication parameter

When all communication parameter settings have been completed, turn the power off and then on to make the new set values take effect.



If you changed the communication parameters, be sure to turn the power OFF and then ON. If this is not done, the higher level device will not be able to recognize the changed values and communication may not be possible.

2.4 Communication Requirements

■ Processing times during data send/receive

When the host computer is using either the polling or selecting procedure for communication, the following processing times are required for PG500 to send data:

- Response wait time after PG500 sends BCC in polling procedure
- Response wait time after PG500 sends ACK or NAK in selecting procedure



Response send time is time when interval time is set at 0 ms.

RKC communication (Polling procedure) processing times

Procedure details	Time
Response send time after PG500 receives ENQ	3 ms max.
Response send time after PG500 receives ACK	3 ms max.
Response send time after PG500 receives NAK	3 ms max.
Response send time after PG500 sends BCC	1 ms max.

RKC communication (Selecting procedure) processing times

Procedure details	Time
Response send time after PG500 receives BCC	34 ms max.
Response wait time after PG500 sends ACK	1 ms max.
Response wait time after PG500 sends NAK	1 ms max.

Modbus processing times

Procedure details	Time
Read holding registers [03H] Response send time after the slave receives the query message	360 ms max.
Preset single register [06H] Response send time after the slave receives the query message	25 ms max.
Diagnostics (loopback test) [08H] Response send time after the slave receives the query message	15 ms max.
Preset multiple registers [10H] Response send time after the slave receives the query message (When 123 registers are collectively write)	360 ms max.

■ RS-485 (2-wire system) send/receive timing (RKC communication)

RS-485 communication is conducted through two wires, therefore, the transmission and reception of data requires precise timing.

● Polling procedure

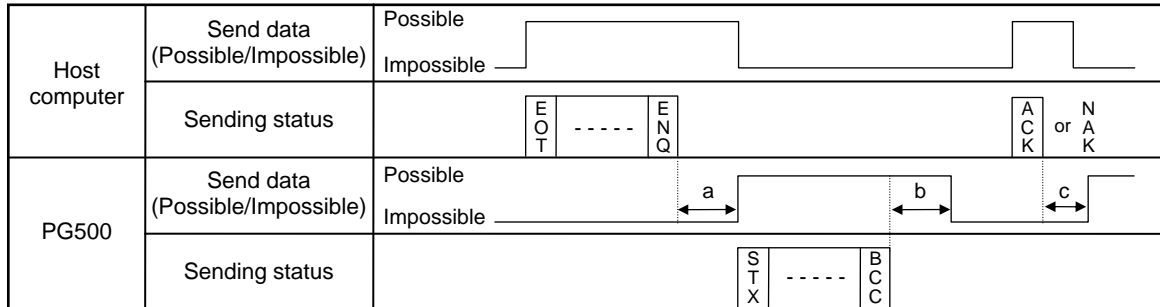

a: Response send time after the PG500 receives [ENQ] + Interval time

b: Response send time after the PG500 sends BCC

c: Response send time after the PG500 receives [ACK] + Interval time or
Response send time after the PG500 receives [NAK] + Interval time

● Selecting procedure

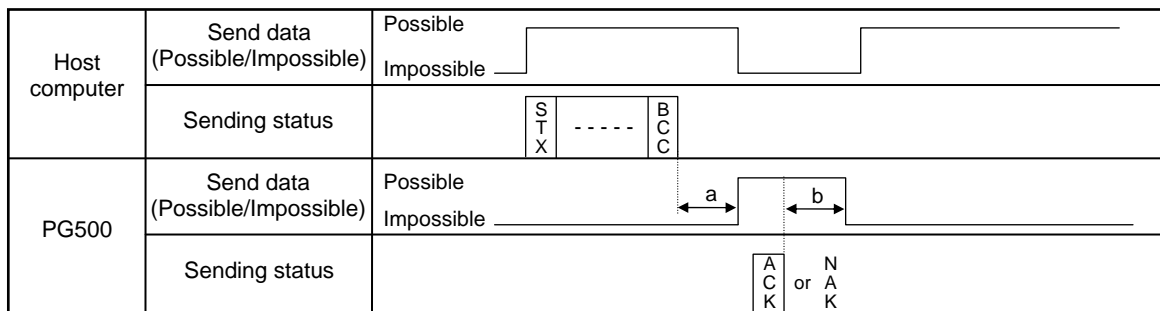

a: Response send time after the PG500 receives BCC + Interval time

b: Response wait time after the PG500 sends ACK or Response wait time after the PG500 sends NAK



To switch the host computer from transmission to reception, send data must be on line.



The following processing times are required for the PG500 to process data:

- In polling procedure, Response wait time after the PG500 sends BCC
- In selecting procedure, Response wait time after the PG500 sends ACK or NAK

■ Fail-safe

A transmission error may occur if the transmission line is disconnected, shorted or set to the high-impedance state. In order to prevent the above error, it is recommended that the fail-safe function be provided on the receiver side of the host computer. The fail-safe function can prevent a framing error from its occurrence by making the receiver output stable to the MARK (1) when the transmission line is in the high-impedance state.

3. RKC COMMUNICATION PROTOCOL

The PG500 uses the polling/selecting method to establish a data link.

The basic procedure is followed ANSI X3.28-1976 subcategories 2.5 and A4 basic mode data transmission control procedure (Fast selecting is the selecting method used in this PG500).

- The polling/selecting procedures are a centralized control method where the host computer controls the entire process. The host computer initiates all communication so the PG500 responds according to queries and commands from the host.
- The code use in communication is 7-bit ASCII code including transmission control characters. The transmission control characters are EOT (04H), ENQ (05H), ACK (06H), NAK (15H), STX (02H) and ETX (03H). The figures in the parenthesis indicate the corresponding hexadecimal number.

3.1 Polling

Polling is the action where the host computer requests one of the connected PG500s to transmit data.

An example of the polling procedure is shown below:

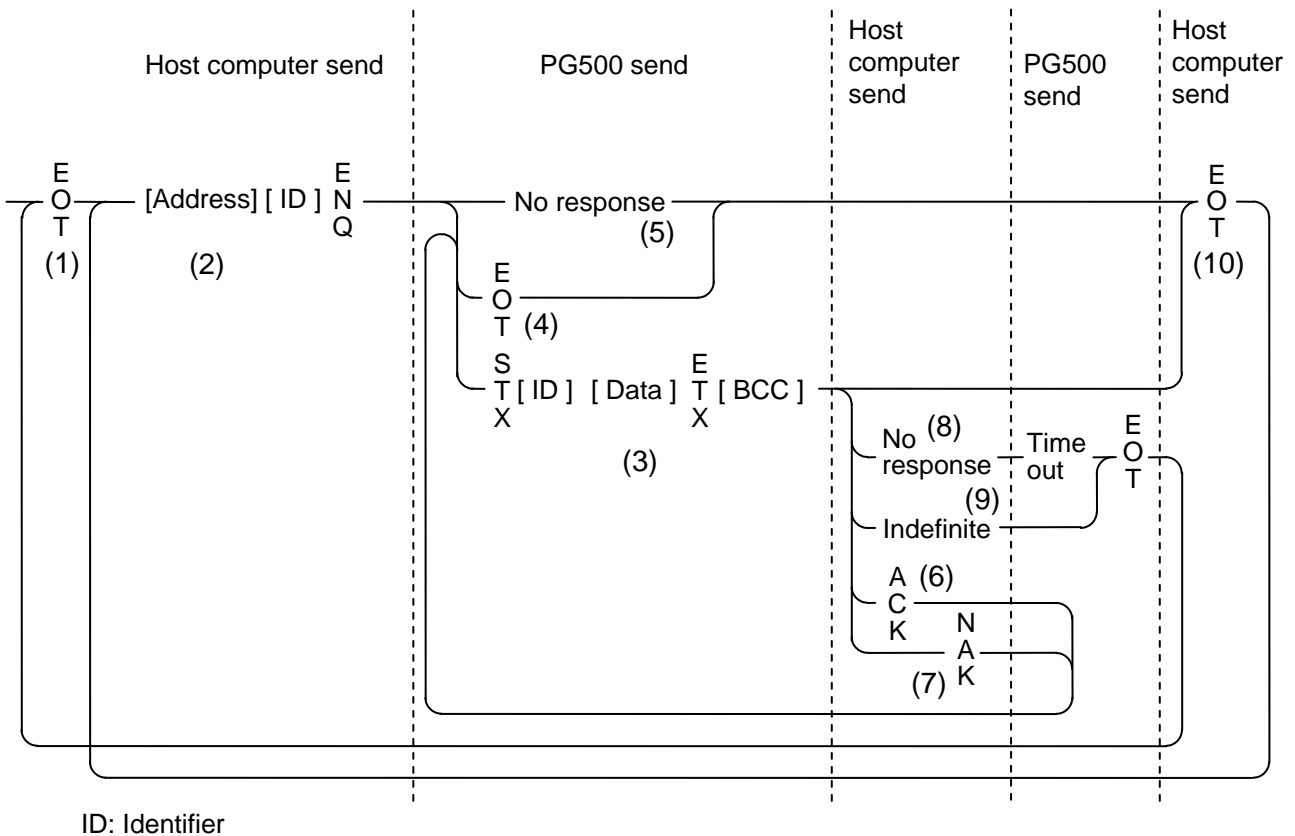

3.1.1 Polling procedures

(1) Data link initialization

Host computer sends EOT to the PG500s to initiate data link before polling sequence.

(2) Data sent from host computer - Polling sequence

The host computer sends the polling sequence in the following formats:

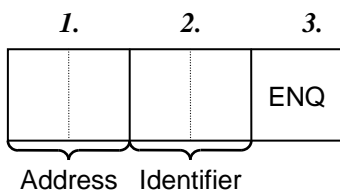

Example:

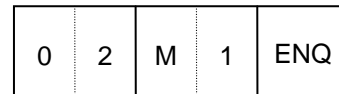

1. Address (2 digits)

The device address specifies the PG500 to be polled and each PG500 must have its own unique device address.

This data is a device address of the PG500 to be selected and must be the same as the device address set value in item **2.3 Setting (P. 10)**.



The polling address which transmitted a message once becomes effective so long as data link is not initialized by transmit and receive of EOT.

2. Identifier (2 digits)

The identifier specifies the type of data that is requested from the PG500. Always attach the ENQ code to the end of the identifier.



For details, refer to **5. COMMUNICATION DATA LIST (P. 42)**.

3. ENQ

The ENQ is the transmission control character that indicates the end of the polling sequence.

The ENQ must be attached to the end of the identifier.

The host computer then must wait for a response from the PG500.

(3) Data sent from the PG500

If the polling sequence is received correctly, the PG500 sends data in the following format:

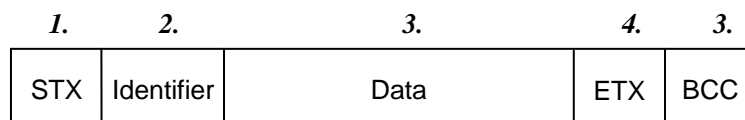

1. STX

STX is the transmission control character which indicates the start of the text transmission (identifier and data).

2. Identifier (2 digits)

The identifier indicates the type of data (measured value, status and set value) sent to the host computer.

 For details, refer to **5. COMMUNICATION DATA LIST (P. 42)**.

3. Data (6 digits)

Data indicated by the identifier belonging to the PG500. It is expressed in decimal ASCII code including a minus sign (-) and a decimal point. Data is not zero-suppressed.

 The data of “Model codes: ID” has 32 digits.
The data of “ROM version monitor: VR” has 9 digits.

4. ETX

ETX is a transmission control character used to indicate the end of text transmission.

5. BCC

BCC (Block Check Character) detects error by using horizontal parity (even number).

Calculation method of BCC: *Exclusive OR* all data and characters from STX through ETX, not including STX.

Example:

STX	M	1	0	1	0	0	.	0	ETX	BCC
-----	---	---	---	---	---	---	---	---	-----	-----

4DH 31H 30H 31H 30H 30H 2EH 30H 03H ← Hexadecimal numbers

$$BCC = 4DH \oplus 31H \oplus 30H \oplus 31H \oplus 30H \oplus 30H \oplus 2EH \oplus 30H \oplus 03H = 60H$$

(\oplus : Exclusive OR)

Value of BCC becomes 60H

(4) EOT sent from the PG500 (Ending data transmission from the PG500)

In the following cases, the PG500 makes a timeout judgment after about 3 seconds, sends EOT, and ends the data link:

- When the specified identifier is invalid
- When all the data has been sent
- When there is an error in the data type

(5) No response from the PG500

The PG500 will not respond if the polling address is not received correctly. It may be necessary for the host computer to take corrective action such as a time-out.

- When a unit address is different
- When there is an error in the data
- When the number of data digit is longer than the specification.

(6) ACK (Acknowledgment)

An acknowledgment ACK is sent by the host computer when data received is correct.

When the PG500 receives ACK from the host computer, the PG500 will send any remaining data of the next identifier without additional action from the host computer.

 For the identifier, refer to **5. COMMUNICATION DATA LIST (P. 42)**.

When host computer determines to terminate the data link, EOT is sent from the host computer.

(7) NAK (Negative acknowledge)

If the host computer does not receive correct data from the PG500, it sends a negative acknowledgment NAK to the PG500. The PG500 will re-send the same data when NAK is received. This cycle will go on continuously until either recovery is achieved or the data link is corrected at the host computer.

(8) No response from host computer

When the host computer does not respond within approximately three seconds after the PG500 sends data, the PG500 sends EOT to terminate the data link. (Time out: 3 seconds)

(9) Indefinite response from host computer

The PG500 sends EOT to terminate the data link when the host computer response is indefinite.

(10) EOT (Data link termination)

The host computer sends EOT message when it is necessary to suspend communication with the PG500 or to terminate the data link due lack of response from the PG500.

3.1.2 Polling procedure example (When the host computer requests data)

■ Normal transmission

(1) When the measured value (PV) monitor (identifier: M1) is polled

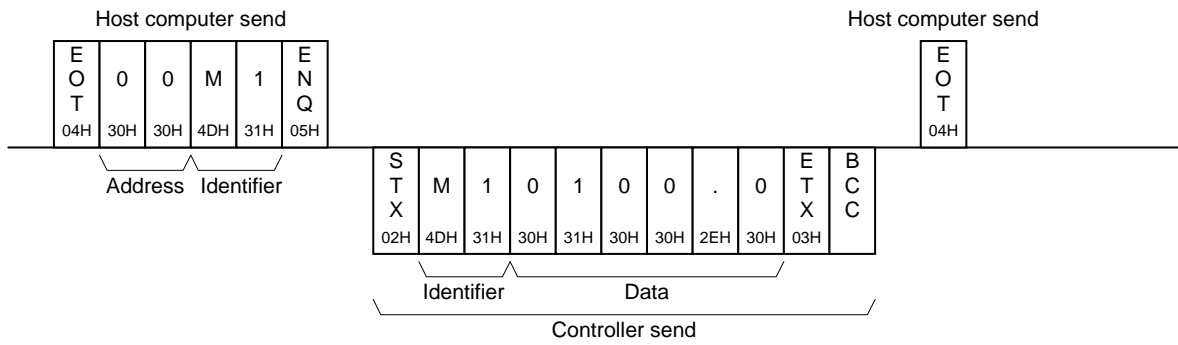

(2) Polling the next identifier with ACK (acknowledgment) after polling ends

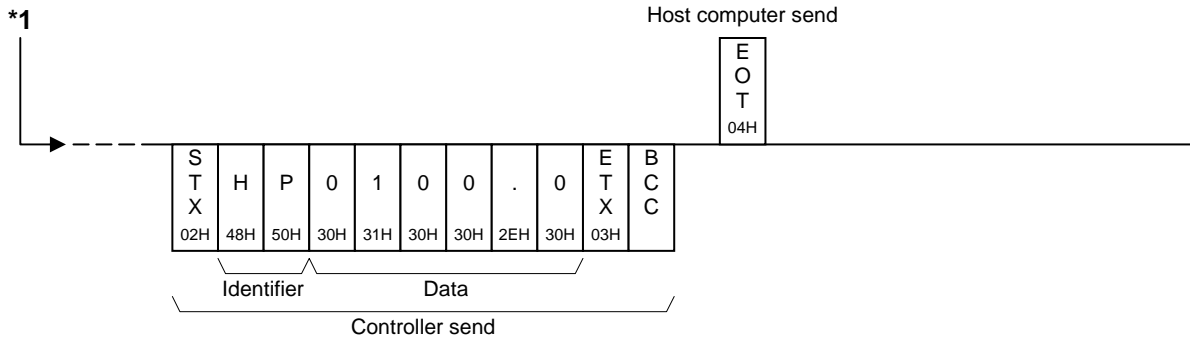
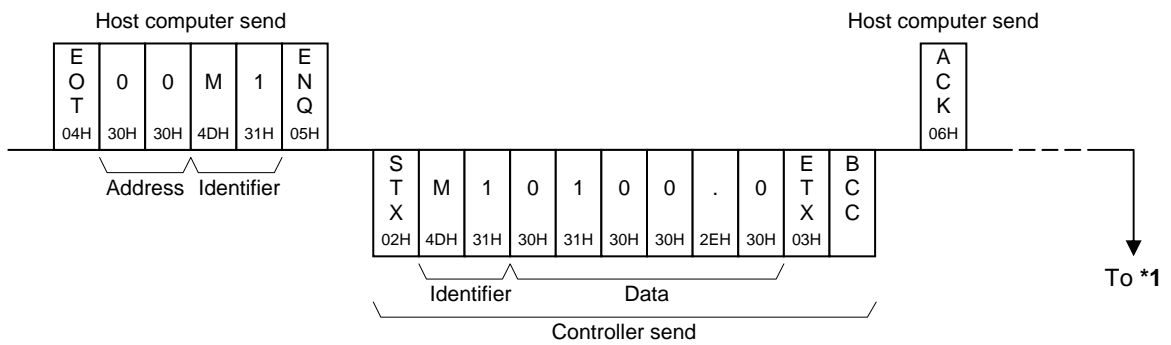

■ Error transmission

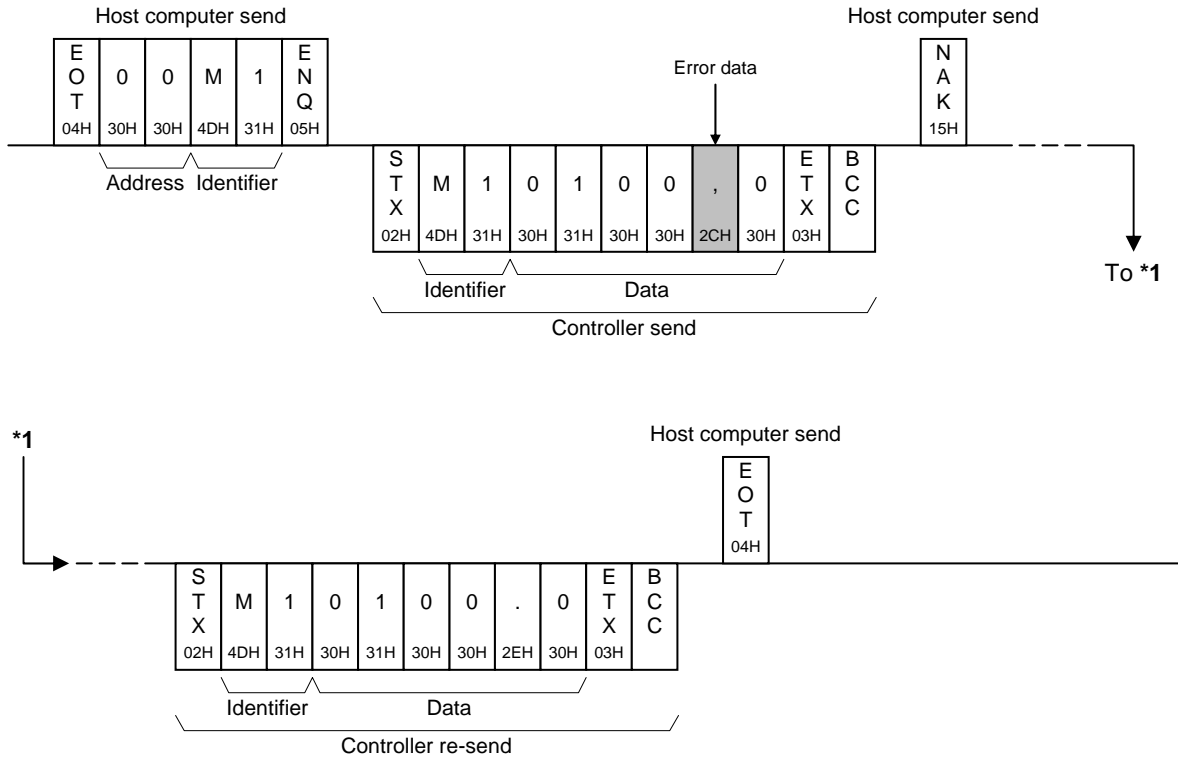

3.2 Selecting

Selecting is the action where the host computer requests one of the connected PG500s to receive data. An example of the selecting procedure is shown below:

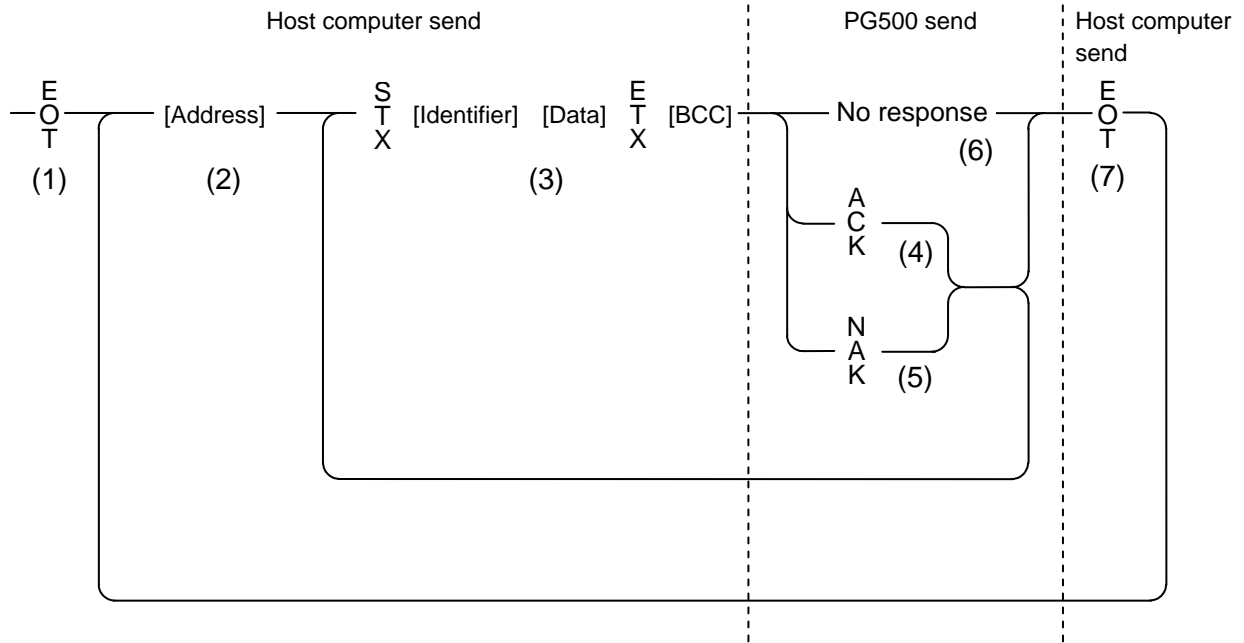

3.2.1 Selecting procedures

(1) Data link initialization

Host computer sends EOT to the PG500s to initiate data link before selecting sequence.

(2) Sending selecting address from the host computer

Host computer sends selecting address for the selecting sequence.

■ Address (2 digits)

This data is a device address of the PG500 to be selected and must be the same as the device address set value in item **2.3 Setting (P. 10)**.



As long as the data link is not initialized by sending or receiving EOT, the selecting address once sent becomes valid.

(3) Data sent from the host computer

	1.	2.		
STX	Identifier	Data	ETX	BCC

 For the STX, ETX and BCC, refer to **3.1 Polling (P. 18)**.

1. Identifier (2 digits)

The identifier specifies the type of data that is requested from the PG500, such as set value.

 For details, refer to **5. COMMUNICATION DATA LIST (P. 42)**.

2. Data

Data which is indicated by an identifier of the PG500 is expressed in decimal ASCII code including a minus sign (-) and a decimal point. The channel number can be zero-suppressed.

The number of digits varies depending on the type of identifier. (Within 6 digits)

● About numerical data**Numerical data which the PG500 can receive**

- Data with numbers below the decimal point omitted or zero-suppressed data can be received.

(Number of digits: Within 6 digits)

<Example> When data send with -001.5, -01.5, -1.5, -1.50, -1.500 at the time of -1.5, PG500 can receive data.

- When the host computer sends data containing a decimal point to an item without a decimal point, the PG500 receives a message rounded down to the nearest whole number.

<Example> When setting range is 0 to 200, the PG500 will receive as follows:

Send data	0.5	100.5
Receive data	0	100

- The PG500 receives the value based on the decided number of places after decimal point. Any number beyond the established number of decimal points will be cut off.

<Example> When setting range is -10.00 to +10.00, the PG500 will receives as follows:

Send data	-5	-058	.05	-0
Receive data	-0.50	-0.05	0.05	0.00

Numerical data which the PG500 can not receive

When the host computer sends abnormal character data, the PG500 returns NAK as a response.

<Example> Only minus sign (there is no figure)

Only decimal point (period)

(4) ACK (Acknowledgment)

An acknowledgment ACK is sent by the PG500 when data received is correct. When the host computer receives ACK from the PG500, the host computer will send any remaining data. If there is no more data to be sent to the PG500, the host computer sends EOT to terminate the data link.

(5) NAK (Negative acknowledge)

If the PG500 does not receive correct data from the host computer, it sends a negative acknowledgment NAK to the host computer. Corrections, such as re-send, must be made at the host computer. The PG500 will send NAK in the following cases:

- When an error occurs on communication the line (parity, framing error, etc.)
- When a BCC check error occurs
- When there is an error in the data.
- When receive data exceeds the setting range
- When the specified identifier is invalid
- When receive data is the identifier of RO (read only)

(6) No response from PG500

The PG500 does not respond when it cannot receive the selecting address, STX, ETX or BCC.

(7) EOT (Data link termination)

The host computer sends EOT when there is no more data to be sent from the host computer or there is no response from the PG500.

3.2.2 Selecting procedure example (When the host computer sends the set values)

■ Normal transmission

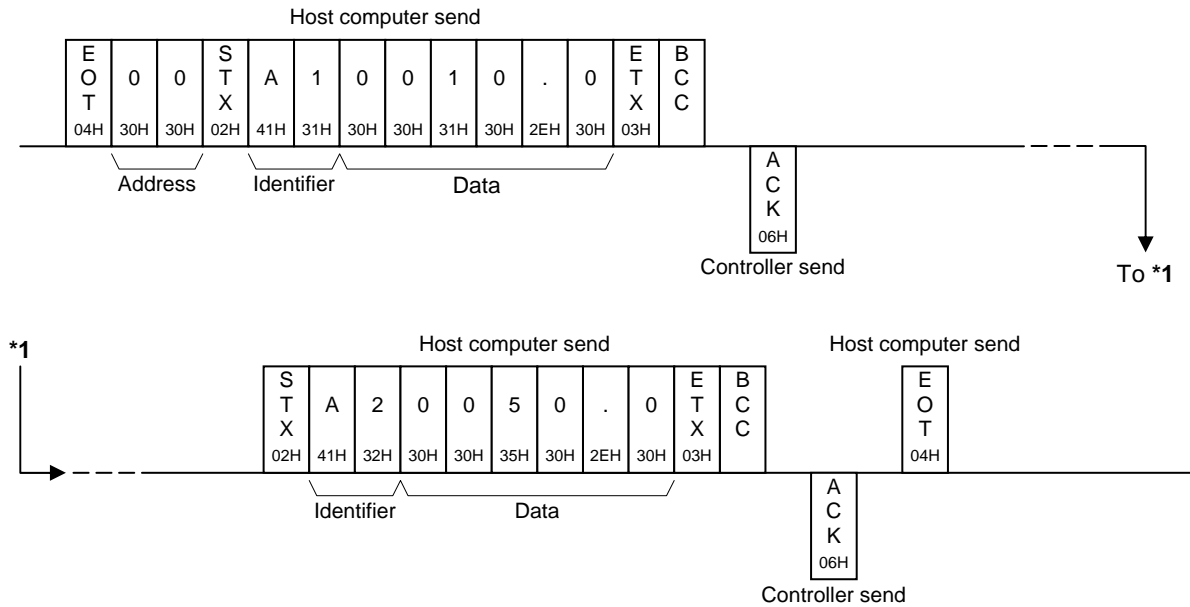

■ Error transmission

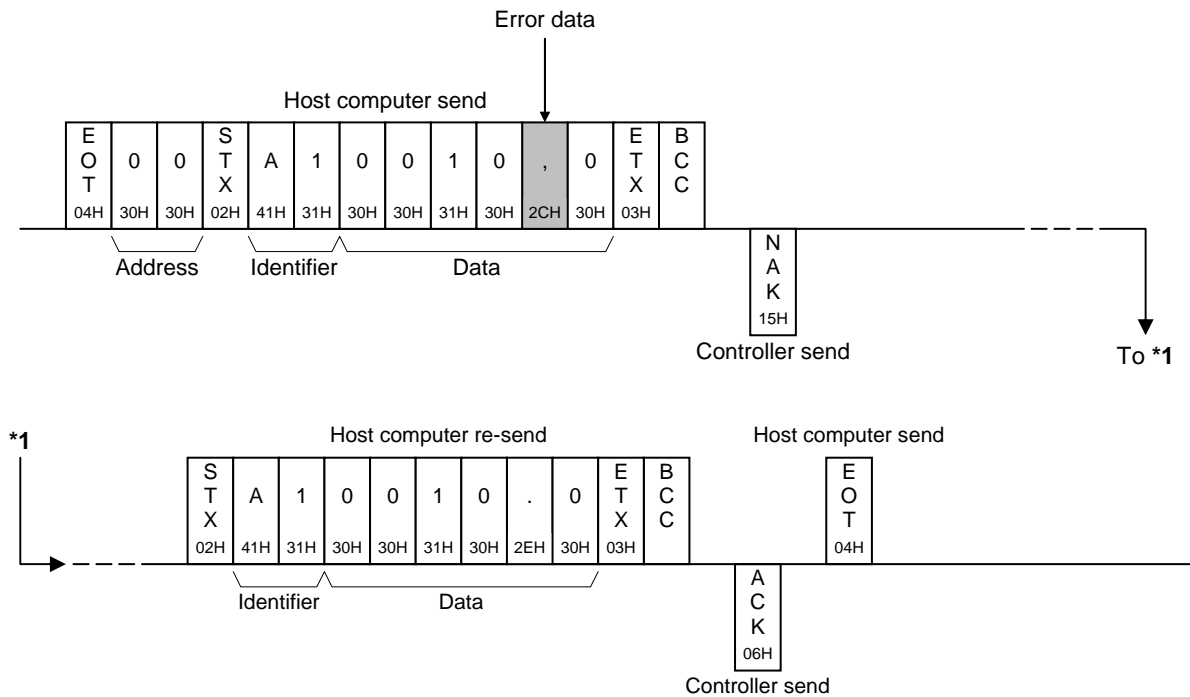

4. MODBUS COMMUNICATION PROTOCOL

The master controls communication between master and slave. A typical message consists of a request (query message) sent from the master followed by an answer (response message) from the slave. When master begins data transmission, a set of data is sent to the slave in a fixed sequence. When it is received, the slave decodes it, takes the necessary action, and returns data to the master.

4.1 Message Format

The message consists of four parts: slave address, function code, data, and error check code which are always transmitted in the same sequence.

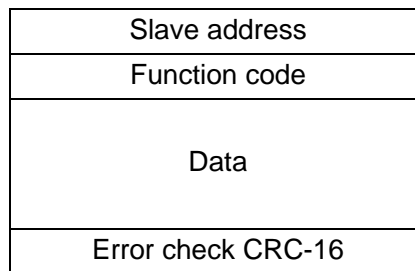

Message format

■ Slave address

The slave address is a number from 1 to 99 manually set at the front key panel of the controller.

 For details, refer to **2.3 Setting (P. 10)**.

Although all connected slave units receive the query message sent from the master, only the slave with the slave address coinciding with the query message will accept the message.

■ Function code

The function codes are the instructions set at the master and sent to the slave describing the action to be executed. The function codes are included when the slave responds to the master.

 For details, refer to **4.2 Function Code (P. 29)**.

■ Data

The data to execute the function specified by the function code is sent to the slave and corresponding data returned to the master from the slave.

 For details, refer to **4.6 Register Read and Write (P. 34)**, **4.7 Data Configuration (P. 38)** and **5. COMMUNICATION DATA LIST (P. 42)**.

■ Error check

An error checking code (CRC-16: Cyclic Redundancy Check) is used to detect an error in the signal transmission.

 For details, refer to **4.5 Calculating CRC-16 (P. 31)**.

4.2 Function Code

Function code contents

Function code (Hexadecimal)	Function	Contents
03H	Read holding registers	Measured value (PV), Alarm status monitor, etc.
06H	Preset single register	Alarm set value, PV bias, etc.
08H	Diagnostics (loopback test)	Loopback test
10H	Preset multiple registers	Alarm set value, PV bias, etc.

Message length of each function (Unit: byte)

Function code (Hexadecimal)	Function	Query message		Response message	
		Min	Max	Min	Max
03H	Read holding registers	8	8	7	255
06H	Preset single register	8	8	8	8
08H	Diagnostics (loopback test)	8	8	8	8
10H	Preset multiple registers	11	255	8	8

4.3 Communication Mode

Signal transmission between the master and slaves is conducted in Remote Terminal Unit (RTU) mode.

Items	Contents
Data bit length	8-bit (Binary)
Start mark of message	Unused
End mark of message	Unused
Message length	Refer to 4.2 Function code
Data time interval	Less than 24-bit time *
Error check	CRC-16 (Cyclic Redundancy Check)

* When sending a command message from the master, set intervals of data configuring one message to time shorter than the 24-bit time. If time intervals become time longer than the 24-bit time the relevant slave assumes that message sending from the master is terminated and there is no response.

4.4 Slave Responses

(1) Normal response

- In the response message of the Read Holding Registers, the slave returns the read out data and the number of data items with the same slave address and function code as the query message.
- In the response message of the Preset Single Register, the slave returns the same message as the query message.
- In the response message of the Diagnostics (Loopback test), the slave returns the same message as the query message.

(2) Defective message response

- If the query message from the master is defective, except for transmission error, the slave returns the error response message without any action.

Slave address
Function code
Error code
Error check CRC-16

Error response message

- If the self-diagnostic function of the slave detects an error, the slave will return an error response message to all query messages.
- The function code of each error response message is obtained by adding 80H to the function code of the query message.

Error code	Contents
1	Function code error (An unsupported function code was specified)
2	When the mismatched address is specified.
3	When the specified number of data items in the query message exceeds the maximum number of data items available
4	Self-diagnostic error response

(3) No response

The slave ignores the query message and does not respond when:

- The slave address in the query message does not coincide with any slave address settings.
- The CRC code of the master does not coincide with that of the slave.
- Transmission error such as overrun, framing, parity and etc., is found in the query message.
- Data time interval in the query message from the master exceeds 24-bit time.

4.5 Calculating CRC-16

The Cyclic Redundancy Check (CRC) is a 2 byte (16-bit) error check code. After constructing the data message, not including start, stop, or parity bit, the master calculates a CRC code and appends this to the end of the message. The slave will calculate a CRC code from the received message, and compare it with the CRC code from the master. If they do not coincide, a communication error has occurred and the slave does not respond.

The CRC code is formed in the following sequence:

1. Load FFFFH to a 16-bit CRC register.
2. *Exclusive OR* (\oplus) the first byte (8 bits) of the message with the CRC register. Return the result to the CRC register.
3. Shift the CRC register 1 bit to the right.
4. If the carry flag is 1, *exclusive OR* the CRC register with A001 hexadecimal and return the result to the CRC register. If the carry flag is 0, repeat step 3.
5. Repeat step 3 and 4 until there have been 8 shifts.
6. *Exclusive OR* the next byte (8 bits) of the message with the CRC register.
7. Repeat step 3 through 6 for all bytes of the message (except the CRC).
8. The CRC register contains the 2 byte CRC error code. When they are appended to the message, the low-order byte is appended first, followed by the high-order byte.

■ The flow chart of CRC-16

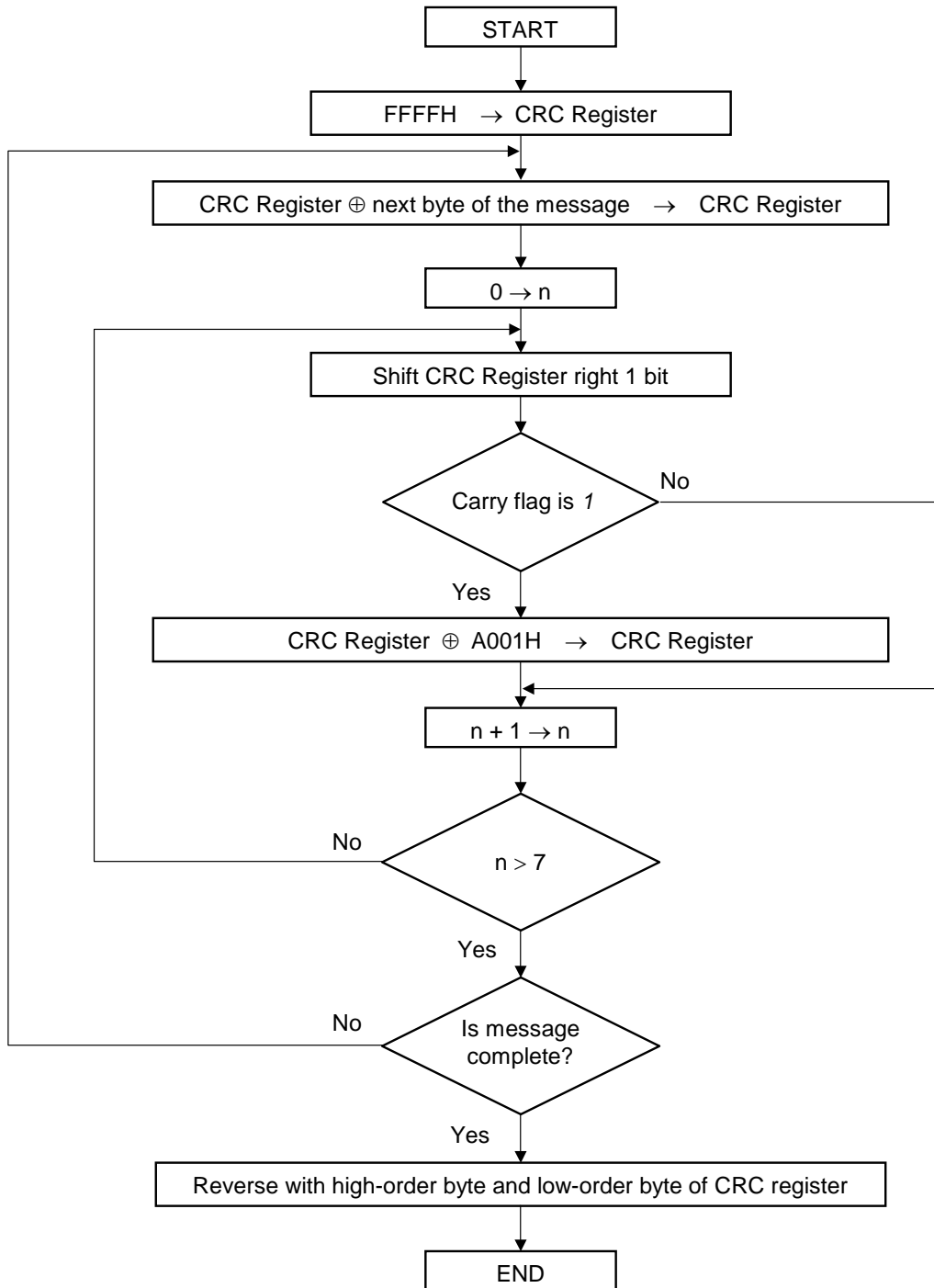

The ⊕ symbol indicates an *exclusive OR* operation. The symbol for the number of data bits is *n*.

■ Example of a CRC calculation in the 'C' language

This routine assumes that the data types 'uint16' and 'uint8' exists. These are unsigned 16-bit integer (usually an 'unsigned short int' for most compiler types) and unsigned 8-bit integer (unsigned char). 'z_p' is a pointer to a Modbus message, and 'z_message_length' is its length, excluding the CRC. Note that the Modbus message will probably contain NULL characters and so normal C string handling techniques will not work.

```
uint16 calculate_crc (byte *z_p, uint16 z_message_length)

/* CRC runs cyclic Redundancy Check Algorithm on input z_p      */
/* Returns value of 16 bit CRC after completion and             */
/* always adds 2 crc bytes to message                          */
/* returns 0 if incoming message has correct CRC              */

{
    uint16 CRC= 0xffff;
    uint16 next;
    uint16 carry;
    uint16 n;
    uint8 crch, crcl;

    while (z_message_length--) {
        next = (uint16) *z_p;
        CRC ^= next;
        for (n = 0; n < 8; n++) {
            carry = CRC & 1;
            CRC >>= 1;
            if (carry) {
                CRC ^= 0xA001;
            }
        }
        z_p++;
    }
    crch = CRC / 256;
    crcl = CRC % 256
    z_p [z_message_length++] = crcl;
    z_p [z_message_length] = crch;
    return CRC;
}
```

4.6 Register Read and Write

4.6.1 Read holding registers [03H]

The query message specifies the starting register address and quantity of registers to be read.

The contents of the holding registers are entered in the response message as data, divided into two parts: the high-order 8-bit and the low-order 8-bit, arranged in the order of the register numbers.

Example: The contents of the four holding registers from 00E0H [Measured value (PV)] to 00E3H [Alarm 2 state monitor] are the read out from slave address 2.

Query message

Slave address		02H	
Function code		03H	
Starting No.	High	00H	} First holding register address
	Low	E0H	
Quantity	High	00H	} The setting must be between 1 (0001H) and 125 (007DH).
	Low	04H	
CRC-16	High	45H	
	Low	CCH	

Normal response message

Slave address		02H	
Function code		03H	
Number of data		08H	→ Number of holding registers × 2
First holding register contents	High	00H	
	Low	19H	
Next holding register contents	High	00H	
	Low	00H	
Next holding register contents	High	00H	
	Low	00H	
Next holding register contents	High	00H	
	Low	00H	
CRC-16	High	12H	
	Low	52H	

Error response message

Slave address		02H
80H + Function code		83H
Error code		03H
CRC-16	High	F1H
	Low	31H

4.6.2 Preset single register [06H]

The query message specifies data to be written into the designated holding register. The write data is arranged in the query message with high-order 8-bit first and low-order 8-bit next. Only R/W holding registers can be specified.

Example: Data is written into the holding register 00F4H [Alarm 1 set value] of slave address 1.

Query message

Slave address		01H	
Function code		06H	
Holding register number	High	00H	} Any data within the range
	Low	F4H	
Write data	High	00H	
	Low	32H	
CRC-16	High	49H	
	Low	EDH	

Normal response message

Slave address		01H	} Contents will be the same as query message data.
Function code		06H	
Holding register number	High	00H	
	Low	F4H	
Write data	High	00H	
	Low	32H	
CRC-16	High	49H	
	Low	EDH	

Error response message

Slave address		01H
80H + Function code		86H
Error code		02H
CRC-16	High	C3H
	Low	A1H

4.6.3 Diagnostics (Loopback test) [08H]

The master's query message will be returned as the response message from the slave.
 This function checks the communication system between the master and slave (the controller).

Example: Loopback test for slave address 1

Query message

Slave address		01H	
Function code		08H	
Test code	High	00H	} Test code must be set to 00.
	Low	00H	
Data	High	1FH	} Any pertinent data
	Low	34H	
CRC-16	High	E9H	
	Low	ECH	

Normal response message

Slave address		01H	
Function code		08H	
Test code	High	00H	} Contents will be the same as query message data.
	Low	00H	
Data	High	1FH	
	Low	34H	
CRC-16	High	E9H	
	Low	ECH	

Error response message

Slave address		01H
80H + Function code		88H
Error code		03H
CRC-16	High	06H
	Low	01H

4.6.4 Preset multiple registers [10H]

The query message specifies the starting register address and quantity of registers to be written. The write data is arranged in the query message with high-order 8-bit first and low-order 8-bit next. Only R/W holding registers can be specified.

Example: Data is written into the two holding registers from 00F4H [Alarm 1 set value] to 00F5H [Alarm 2 set value] of slave address 1.

Query message

Slave address		01H	
Function code		10H	
Starting number	High	00H	} First holding register address
	Low	F4H	
Quantity	High	00H	} The setting must be between 1 (0001H) and 123 (007BH).
	Low	02H	
Number of data		04H	→ Number of holding registers × 2
Data to first register	High	00H	} Any pertinent data
	Low	32H	
Data to next register	High	00H	
	Low	32H	
CRC-16	High	DDH	
	Low	02H	

Normal response message

Slave address		01H
Function code		10H
Starting number	High	00H
	Low	F4H
Quantity	High	00H
	Low	02H
CRC-16	High	00H
	Low	3AH

Error response message

Slave address		01H
80H + Function code		90H
Error code		02H
CRC-16	High	CDH
	Low	C1H

4.7 Caution for Handling Communication Data

- The numeric range of data used in Modbus protocol is 0000H to FFFFH. Only the set value within the setting range is effective.



FFFFH represents -1.

- The Modbus protocol does not recognize data with decimal points during communication.

Example: When Measured value (PV) is 5.0 MPa,
 5.0 is processed as 50,
 50 = 0032H

Measured value (PV)	High	00H
	Low	32H

- If data (holding register) exceeding the accessible address range is accessed, an error response message is returned.
- Read data of unused item is a default value.
- Any attempt to write to an unused item is not processed as an error. Data cannot be written into an unused item.
- If data range or address error occurs during data writing (Write Action), it is not processed as an error. Normal data is written in data register but data with error is not written; therefore, it is recommended to confirm data of changed items after the data setting.
- An attribute of the item for functions which are not in the indicator is RO (read only). If read action to this item is performed, the read data will be "0." If write action to this item is performed, no error message is indicated and no data is written.
- Commands should be sent at time intervals of 30 bits after the master receives the response message.

4.8 How to Use Modbus Data Mapping

In this communication, it is possible to continuously read/write data by freely specifying 16 sets of data.

Register address to specify mapping data: 1000H to 100FH

Register address to actually read/write data: 1500H to 150FH

Register address of data which can be mapped: Refer to **5.2 Communication Data List (P. 44)**.

 For the data mapping address list, refer to the **4.9 Modbus Data Mapping Address (P. 40)**.

Example 1: When mapping Measured value (PV), Alarm 1 state monitor, Alarm 2 state monitor and Alarm output state monitor to the register addresses from 1500H to 1503H

For data mapping			Mapping data		
Name	Register address		Name	Register address	
	HEX	DEC		HEX	DEC
Register address setting 1 Read/write address: 1500H	1000	4096	Measured value (PV)	00E0	224
Register address setting 2 Read/write address: 1501H	1001	4097	Alarm 1 state monitor	00E2	226
Register address setting 3 Read/write address: 1502H	1002	4098	Alarm 2 state monitor	00E3	227
Register address setting 4 Read/write address: 1503H	1003	4099	Alarm output state monitor	00EC	236

↑ Write to register address (1000H to 1003H)

1. The register address, “00E0H” of the Measured value (PV) to be mapped is written to register address setting 1 (1000H).
2. The register address, “00E2H” of the Alarm 1 state monitor to be mapped is written to register address setting 2 (1001H).
3. The register address, “00E3H” of the Alarm 2 state monitor to be mapped is written to register address setting 3 (1002H).
4. The register address, “00ECH” of the Alarm output state monitor to be mapped is written to register address setting 4 (1003H).
5. The assignment of the register addresses from 1500H to 1503H from/to which data is actually read/written becomes as follows.

Register address		Name
HEX	DEC	
1500	5376	Measured value (PV)
1501	5377	Alarm 1 state monitor
1502	5378	Alarm 2 state monitor
1503	5379	Alarm output state monitor

High-speed communication is performed by reading or writing data in the consecutive register addresses from 1500H to 1503H.

4.9 Modbus Data Mapping Address

■ Register address for data mapping

No.	Name	Modbus register address		Attribute	Data range	Factory set value
		HEX	DEC			
1	Register address setting 1 Read/write address: 1500H	1000	4096	RW	Decimal: -1 to 4095 (-1: No mapping) Hexadecimal: FFFFH to 0FFFH (FFFFH: No mapping) Set the register address of data to be assigned to 1500H to 150FH.	-1
2	Register address setting 2 Read/write address: 1501H	1001	4097	RW		-1
3	Register address setting 3 Read/write address: 1502H	1002	4098	RW		-1
4	Register address setting 4 Read/write address: 1503H	1003	4099	RW		-1
5	Register address setting 5 Read/write address: 1504H	1004	4100	RW		-1
6	Register address setting 6 Read/write address: 1505H	1005	4101	RW		-1
7	Register address setting 7 Read/write address: 1506H	1006	4102	RW		-1
8	Register address setting 8 Read/write address: 1507H	1007	4103	RW		-1
9	Register address setting 9 Read/write address: 1508H	1008	4104	RW		-1
10	Register address setting 10 Read/write address: 1509H	1009	4105	RW		-1
11	Register address setting 11 Read/write address: 150AH	100A	4106	RW		-1
12	Register address setting 12 Read/write address: 150BH	100B	4107	RW		-1
13	Register address setting 13 Read/write address: 150CH	100C	4108	RW		-1
14	Register address setting 14 Read/write address: 150DH	100D	4109	RW		-1
15	Register address setting 15 Read/write address: 150EH	100E	4110	RW		-1
16	Register address setting 16 Read/write address: 150FH	100F	4111	RW		-1

■ Register address for data read/writes

No.	Name	Modbus register address		Attribute	Data range	Factory set value
		HEX	DEC			
1	Data specified by register address setting 1 (1000H)	1500	5376		Differs depending on data specified.	
2	Data specified by register address setting 2 (1001H)	1501	5377			
3	Data specified by register address setting 3 (1002H)	1502	5378			
4	Data specified by register address setting 4 (1003H)	1503	5379			
5	Data specified by register address setting 5 (1004H)	1504	5380			
6	Data specified by register address setting 6 (1005H)	1505	5381			
7	Data specified by register address setting 7 (1006H)	1506	5382			
8	Data specified by register address setting 8 (1007H)	1507	5383			
9	Data specified by register address setting 9 (1008H)	1508	5384			
10	Data specified by register address setting 10 (1009H)	1509	5385			
11	Data specified by register address setting 11 (100AH)	150A	5386			
12	Data specified by register address setting 12 (100BH)	150B	5387			
13	Data specified by register address setting 13 (100CH)	150C	5388			
14	Data specified by register address setting 14 (100DH)	150D	5389			
15	Data specified by register address setting 15 (100EH)	150E	5390			
16	Data specified by register address setting 16 (100FH)	150F	5391			

5. COMMUNICATION DATA LIST

5.1 Reference to Communication Data List

No.	Name	RKC Identifier	Modbus register address		Attribute	Data range	Factory set value
			HEX	DEC			
1	Model code	ID	—	—	RO	Model character code (32-digit)	—
2	ROM version monitor	VR	—	—	RO	Version of ROM built in the instrument (9-digit)	—

(1) Name: Communication data name

(2) RKC identifier: Communication identifier of RKC communication

(3) Modbus register address: Register addresses of each channel
 HEX: Hexadecimal
 DEC: Decimal

(4) Attribute: A method of how communication data items are read or written when viewed from the host computer is described
 RO: Read only data

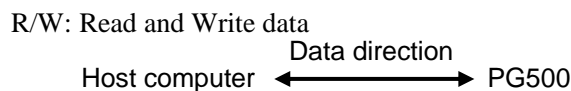
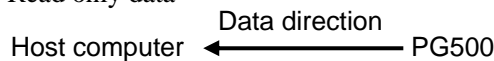

(5) Data range: Read or write range of communication data

• **ASCII code data (RKC communication)**

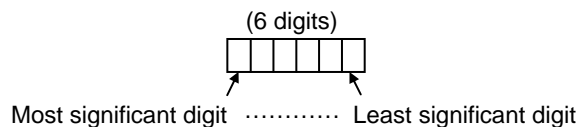

• **16-bit data (Modbus)**

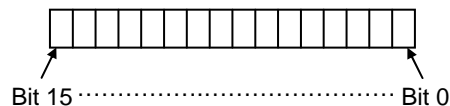

(6) Factory set value: Factory set value of communication data



Communication data includes both Normal setting data and Engineering setting data.

Normal setting data: No.1 to 24

Engineering setting data : No. 25 to 73

The Engineering setting data should be set according to the application before setting any parameter related to operation. Once the Engineering setting data are set correctly, no further changes need to be made to parameters for the same application under normal conditions. If they are changed unnecessarily, it may result in malfunction or failure of the instrument. RKC will not bear any responsibility for malfunction or failure as a result of improper changes in the Engineering setting.



Data handling when non-existing function is specified (When the specified identifier is invalid).

● **RKC communication**

Polling: The PG500 makes a timeout judgment after about 3 seconds, sends EOT, and ends the data link.

Selecting: The PG500 sends a negative acknowledgment NAK to the host computer. Corrections, such as re-send, must be made at the host computer.

● **Modbus**

An attribute of the item for functions which are not in the indicator is RO (read only).

If read action to this item is performed, the read data will be "0." If write action to this item is performed, no error message is indicated and no data is written.



For cautions of data changing, refer to **5.3 The communication data which will be initialized or changed, if the communication data are changed (P. 54)**



For the Data mapping, refer to **4.8 How to Use Data Mapping (P. 39)**.



For details on the data, refer to the **PG500 Operation Manual (IMR02F02-E□)**.

5.2 Communication Data List (RKC communication/Modbus)

No.	Name	RKC Identifier	Modbus register address		Attribute	Data range	Factory set value
			HEX	DEC			
1	Model code	ID	—	—	RO	Model character code (32-digit)	—
2	ROM version monitor	VR	—	—	RO	Version of ROM built in the instrument (9-digit)	—
3	Measured value (PV)	M1	00E0	224	RO	Pressure display low to Pressure display high Varies with the setting of the Input decimal point position.	—
4	Burnout state monitor	B1	00E1	225	RO	0: OFF 1: ON	—
5	Alarm 1 state monitor	AA	00E2	226	RO	0: OFF 1: ON	—
6	Alarm 2 state monitor	AB	00E3	227	RO		—
7	Alarm 3 state monitor	AC	00E4	228	RO		—
8	Alarm 4 state monitor	AD	00E5	229	RO		—
—	Unused	—	00E6	230	—	—	—
—	Unused	—	00E7	231	—	—	—
9	Peak hold monitor	HP	00E8	232	RO	Pressure display low to Pressure display high Varies with the setting of the Input decimal point position.	—
10	Bottom hold monitor	HQ	00E9	233	RO	At input break: Display range limit	—
11	Error code	ER	00EA	234	RO	RKC communication 1: Adjustment data error 2: Back-up error 4: A/D conversion error 16: Auto zero/auto calibration error 128: Watchdog timer error 256: Program error (stack) 2048: Program error (busy)	—
						Modbus (Bit data) Bit 0: Adjustment data error Bit 1: Back-up error Bit 2: A/D conversion error Bit 3: Unused Bit 4: Auto zero/auto calibration error Bit 5 to Bit 6: Unused Bit 7: Watchdog timer error Bit 8: Program error (stack) Bit 9: Unused Bit 10: Unused Bit 11: Program error (busy) Bit 12 to Bit 15: Unused Data 0: OFF 1: ON [Decimal number: 0 to 2455]	—

No.	Name	RKC Identifier	Modbus register address		Attribute	Data range	Factory set value
			HEX	DEC			
14	Digital input (DI) state monitor	L1	00EB	235	RO	RKC communication Least significant digit: The state of auto zero (DI1) 2nd digit: The state of hold reset (DI2) 3rd digit: The state of Interlock release (DI3) 4rd digit to Most significant digit: Unused Data 0: Contact open 1: Contact closed	—
						Modbus (Bit data) Bit 0: The state of auto zero (DI1) Bit 1: The state of hold reset (DI2) Bit 2: The state of Interlock release (DI3) Bit 3 to Bit 15: Unused Data 0: Contact open 1: Contact closed [Decimal number: 0 to 7]	—
15	Alarm output state monitor	Q1	00EC	236	RO	RKC communication Least significant digit: The state of alarm 1 output 2nd digit: The state of alarm 2 output 3rd digit: The state of alarm 3 output 4th digit: The state of alarm 4 output 5th digit to Most significant digit: Unused Data 0: OFF 1: ON	—
						Modbus (Bit data) Bit 0: The state of alarm 1 output Bit 1: The state of alarm 2 output Bit 2: The state of alarm 3 output Bit 3: The state of alarm 4 output Bit 4 to Bit 15: Unused Data 0: OFF 1: ON [Decimal number: 0 to 16]	—
16	Integrated operating time monitor	UT	00ED	237	RO	0 to 19999 hours	—
—	Unused	—	00EE	238	—	—	—
—	Unused	—	00EF	239	—	—	—

5. COMMUNICATION DATA LIST

No.	Name	RKC Identifier	Modbus register address		Attribute	Data range	Factory set value
			HEX	DEC			
17	Auto zero	AZ	00F0	240	R/W	0: Normal state 1: Auto zero execution When "1" is written, auto zero starts. When done, the value reverts to "0." 3: Error When "0" is written, returns to a normal state.	0
18	Auto calibration	FS	00F1	241	R/W	0: Normal state 1: Auto calibration execution When "1" is written, auto calibration starts. When done, the value reverts to "0." 3: Error When "0" is written, returns to a normal state. This item is valid when using resistance for sensitivity adjustment built-in pressure sensor.	0
19	Hold reset	HR	00F2	242	R/W	0: Hold reset execution 1: Hold state When "0" is written, the hold reset is performed. When done, the value reverts to "1."	1
20	Interlock release	IR	00F3	243	R/W	0: Interlock release execution 1: Interlock state When "0" is written, the interlock is released. When done, the value reverts to "1." This item is invalid when the alarm 1 to 4 Interlock are set to "0: Unused."	1
21	Alarm 1 set value	A1	00F4	244	R/W	Pressure display low to Pressure display high	50
22	Alarm 2 set value	A2	00F5	245	R/W	Varies with the setting of the Input decimal point position.	0
23	Alarm 3 set value	A3	00F6	246	R/W	Signals are output from the alarm outputs (ALM1 to ALM4) if exceeding the alarm set value.	50
24	Alarm 4 set value	A4	00F7	247	R/W	This item is invalid when the alarm type is set to "0: None."	50
—	Unused	—	00F8	248	—	—	—
—	Unused	—	00F9	249	—	—	—

No.	Name	RKC Identifier	Modbus register address		Attribute	Data range	Factory set value
			HEX	DEC			
25	Input type	XI	00FA	250	R/W	0 to 4 Refer to Input type and factory set value table .	Based on model code.
26	Gain setting	GA	00FB	251	R/W	0.500 to 4.000 mV/V or 0.5000 to 1.9999 mV/V Varies with the setting of the Gain setting decimal point position. The setting value varies depending on using pressure sensor. When using our CZ-100P or CZ-200P: Refer to Gain setting and linearizing type (P. 53) . When using resistance for sensitivity adjustment built-in pressure sensor: Set the appropriate gain setting value.	Refer to Input type and factory set value table
27	Display unit	PU	00FC	252	R/W	0: Kg/cm ² 1: MPa 2: bar 3: psi	1
28	Input decimal point position	XU	00FD	253	R/W	0: No decimal place 1: One decimal place 2: Two decimal places 3: Three decimal places	0
29	Pressure display high	XV	00FE	254	R/W	Pressure display low to 19999 Varies with the setting of the Gain setting decimal point position	50
30	Pressure display low	XW	00FF	255	R/W	0 to Pressure display high Varies with the setting of the Gain setting decimal point position	0

Input type and factory set value table

Set value	Input type	Factory set value of gain setting (mV/V)
0	Our CZ-100P/CZ-200P (Standard)	1.500
1	Our CZ-100P/CZ-200P (Explosionproof)	1.500
2	Our CZ-100P/CZ-200P (Standard) [Loose nut: 0.0 to 0.5 MPa, Fixed nut: 0 to 5 MPa]	0.650
3	Our CZ-100P/CZ-200P (Explosionproof) [Loose nut: 0.0 to 0.5 MPa, Fixed nut: 0 to 5 MPa]	0.650
4	3.33 mV/V output type (Pressure sensor made by other companies)	3.330

No.	Name	RKC Identifier	Modbus register address		Attribute	Data range	Factory set value
			HEX	DEC			
31	Linearizing type	LI	0100	256	R/W	0 to 20 The setting value varies depending on using pressure sensor. The setting value varies depending on using pressure sensor. When using our CZ-100P or CZ-200P: Refer to Gain setting and linearizing type (P. 53). When using resistance for sensitivity adjustment built-in pressure sensor: Use a factory set value of "0."	0
32	PV bias	PB	0101	257	R/W	-Input span to +Input span Varies with the setting of the Input decimal point position.	0
33	PV digital filter	F1	0102	258	R/W	0.0 to 100.0 seconds (0.0: Unused)	0
34	PV ratio	PR	0103	259	R/W	0.500 to 1.500 The setting value varies depending on using pressure sensor. Refer to Pressure sensor type and factory set value table.	1.000
—	Unused	—	0104	260	—	—	—

Pressure sensor type and factory set value table

Pressure sensor type	PV ratio set value
When using our CZ-100P or CZ-200P	[Explosionproof specification type] Set the desired correction factor of our safety barrier RZB-001 to the PV ratio (Pr). Thus, an indicated error caused by the use of the safety barrier is corrected. The correction factor is described in the nameplate attached to the safety barrier (RZB-001).
	[Non-explosionproof specification type] Use a factory set value of "1.000."
When using resistance for sensitivity adjustment built-in pressure sensor	The result obtained by auto calibration is reflected to the PV ratio. Manual full scale adjustment can be performed by changing this PV ratio value.

No.	Name	RKC Identifier	Modbus register address		Attribute	Data range	Factory set value
			HEX	DEC			
35	Set lock level	LK	0105	261	R/W	RKC communication Least significant digit: Items other than alarm set value. 2nd digit: Alarm set value 3rd digit to Most significant digit: Unused Data 0: Unlock 1: Lock	0
						Modbus (Bit data) Bit 0: Items other than alarm set value. Bit 1: Alarm set value Bit 2 to Bit 15: Unused Data 0: Unlock 1: Lock [Decimal number: 0 to 3]	0
36	Display timer	TL	0106	262	R/W	0.1 to 10.0 seconds	0.1
37	PV display condition	DU	0107	263	R/W	RKC communication 0 to 255 (Decimal) Set the bit data (Refer to Modbus) after converting it to decimal.	0
						Modbus (Bit data) Bit 0: Minus display of PV value [This item is valid when using voltage (V)/current (I) inputs.] Bit 1: Input error Bit 2: Alarm 1 occurs Bit 3: Alarm 2 occurs Bit 4: Alarm 3 occurs Bit 5: Alarm 4 occurs Bit 6 to Bit 15: Unused Data Bit 0: 0: Minus display 1: Non-minus display Bit 1 to Bit 7: 0: Non-flashing display 1: Flashing display [Decimal number: 0 to 63]	0
38	Input error determination point (high)	AV	0108	264	R/W	Pressure display low – (5 % of input span) to Pressure display high + (5 % of input span) Varies with the setting of the Input decimal point position.	53

No.	Name	RKC Identifier	Modbus register address		Attribute	Data range	Factory set value
			HEX	DEC			
39	Input error determination point (low)	AW	0109	265	R/W	Pressure display low – (5 % of input span) to Pressure display high + (5 % of input span) Varies with the setting of the Input decimal point position.	-2
40	Burnout direction	IB	010A	266	R/W	0: Upscale 1: Downscale Setting of a barn out direction select switch is necessary to select a barn out direction. Refer to Setting of Burnout direction select switch .	0
41	Gain setting decimal point position	GS	010B	267	R/W	3: Three decimal places 4: Four decimal places	3
—	Unused	—	010C	268	—	—	—
42	Shunt resistance output value	OR	010D	269	R/W	40.0 to 100.0 % This item is valid when using resistance for sensitivity adjustment built-in pressure sensor.	80.0
43	Transmission output scale high	HV	010E	270	R/W	Transmission output scale low to Pressure display high Varies with the setting of the Input decimal point position.	50
44	Transmission output scale low	HW	010F	271	R/W	Pressure display low to Transmission output scale high Varies with the setting of the Input decimal point position.	0
45	Transmission output timer	TO	0110	272	R/W	0.1 to 10.0 seconds	0.1

Setting of Burnout direction select switch

Burnout direction is selected by the Burnout direction select switch and Burnout direction (RKC communication: IB, Modbus: 010AH) of parameter. It is necessary to set both setting switch and parameter . Turn the right side switch by a small screwdriver.



Burnout function may not work properly if settings of “Burnout direction select switch” and “Burnout direction” parameter (RKC communication: IB, Modbus: 010AH) do not match each other.

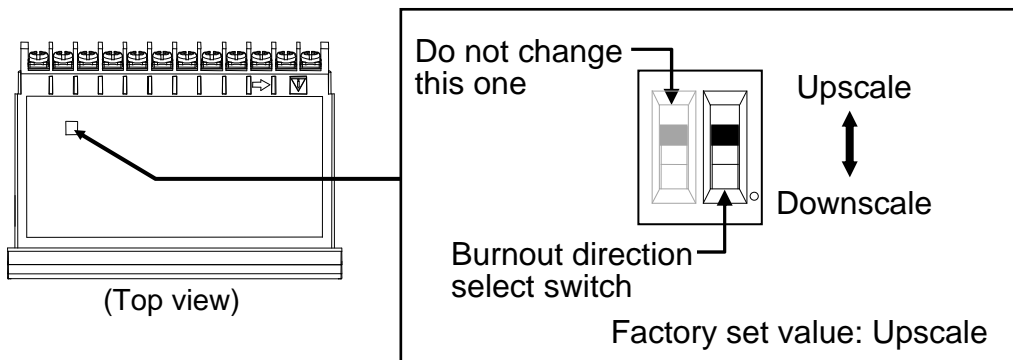

No.	Name	RKC Identifier	Modbus register address		Attribute	Data range	Factory set value
			HEX	DEC			
46	Alarm 1 type	XA	0111	273	R/W	0: None 1: Process high 2: Process low	Based on model code. When not specifying: 1
47	Alarm 1 hold action	WA	0112	274	R/W	0: OFF 1: Hold action ON	Based on model code. When not specifying: 0
48	Alarm 1 interlock	QA	0113	275	R/W	0: Unused (OFF) 1: Used	0
49	Alarm 1 energized/de-energized	NA	0114	276	R/W	0: Energized 1: De-energized	0
50	Alarm 1 differential gap	HA	0115	277	R/W	0 to Input span Varies with the setting of the Input decimal point position.	2
51	Alarm 1 delay timer	TD	0116	278	R/W	0.0 to 600.0 seconds	0.0
52	Alarm 1 action at input error	OA	0117	279	R/W	0: Normal alarm action 1: Forced alarm ON when temperature measured value exceeds the input error determination point (high or low limit).	0
53	Alarm 2 type	XB	0118	280	R/W	0: None 1: Process high 2: Process low	Based on model code. When not specifying: 2
54	Alarm 2 hold action	WB	0119	281	R/W	0: OFF 1: Hold action ON	Based on model code. When not specifying: 0
55	Alarm 2 interlock	QB	011A	282	R/W	0: Unused (OFF) 1: Used	0
56	Alarm 2 energized/de-energized	NB	011B	283	R/W	0: Energized 1: De-energized	0
57	Alarm 2 differential gap	HB	011C	284	R/W	0 to Input span Varies with the setting of the Input decimal point position.	2
58	Alarm 2 delay timer	TG	011D	285	R/W	0.0 to 600.0 seconds	0.0
59	Alarm 2 action at input error	OB	011E	286	R/W	0: Normal alarm action 1: Forced alarm ON when temperature measured value exceeds the input error determination point (high or low limit).	0
60	Alarm 3 type	XC	011F	287	R/W	0: None 1: Process high 2: Process low	Based on model code. When not specifying: 0

5. COMMUNICATION DATA LIST

No.	Name	RKC Identifier	Modbus register address		Attribute	Data range	Factory set value
			HEX	DEC			
61	Alarm 3 hold action	WC	0120	288	R/W	0: OFF 1: Hold action ON	Based on model code. When not specifying: 0
62	Alarm 3 interlock	QC	0121	289	R/W	0: Unused (OFF) 1: Used	0
63	Alarm 3 energized/de-energized	NC	0122	290	R/W	0: Energized 1: De-energized	0
64	Alarm 3 differential gap	HC	0123	291	R/W	0 to Input span Varies with the setting of the Input decimal point position.	2
65	Alarm 3 delay timer	TH	0124	292	R/W	0.0 to 600.0 seconds	0.0
66	Alarm 3 action at input error	OC	0125	293	R/W	0: Normal alarm action 1: Forced alarm ON when temperature measured value exceeds the input error determination point (high or low limit).	0
67	Alarm 4 type	XD	0126	294	R/W	0: None 1: Process high 2: Process low	Based on model code. When not specifying: 0
68	Alarm 4 hold action	WD	0127	295	R/W	0: OFF 1: Hold action ON	Based on model code. When not specifying: 0
69	Alarm 4 interlock	QD	0128	296	R/W	0: Unused (OFF) 1: Used	0
70	Alarm 4 energized/de-energized	ND	0129	297	R/W	0: Energized 1: De-energized	0
71	Alarm 4 differential gap	HD	012A	298	R/W	0 to Input span Varies with the setting of the Input decimal point position.	2
72	Alarm 4 delay timer	TI	012B	299	R/W	0.0 to 600.0 seconds	0.0
73	Alarm 4 action at input error	OD	012C	300	R/W	0: Normal alarm action 1: Forced alarm ON when temperature measured value exceeds the input error determination point (high or low limit).	0
—	Unused	—	012D ⋮ 013A	301 ⋮ 314	—	—	—

■ Gain setting and linearizing type (Only our pressure sensor CZ-100P/CZ-200P)

Set the rated output value (mV/V) and linearizing type symbol to Gain setting (RKC communication: GA, Modbus: 00FBH) and linearizing type (RKC communication: LI, Modbus: 0100H) engraved on the rated nameplate attached to the pressure sensor housing.

● Example of the rated nameplate

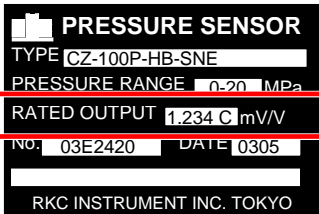

1.234 C

linearizing type symbol
Set it to linearizing type (RKC communication: LI, Modbus S: 0100H) by refer to the **linearizing type symbol table**.
→ Set the “1.”

Rated output value
Set it to Gain setting (RKC communication: GA, Modbus: 00FBH).
→ Set the “1.234.”

Linearizing type symbol table

Set value	Linearizing type symbol	Set value	Linearizing type symbol	Set value	Linearizing type symbol
0	No symbol	7	J	14	S
1	C	8	K	15	T
2	D	9	L	16	U
3	E	10	M	17	V
4	F	11	P	18	W
5	G	12	Q	19	X
6	H	13	R	20	Y



The rated output value (mV/V) of the CZ-100P/CZ-200P is when the cable is at a length of 5 m. When the cable is extended or a cable of a different manufacturer is used, the gain value must be corrected and changed. For details, refer to the **CZ-100P/PCT-300 Resin Pressure Measuring System Instruction Manual (IM100CZ04-E□)** or **CZ-200P Instruction Manual (IM100CZ08-E□)**.

5.3 The communication data which will be initialized or changed, if the communication data are changed



Before changing any communication data setting, always record all communication data settings. And after the change, always check all communication data settings by comparing them with the record taken before the change.

■ The communication data which will be initialized if the Input type is changed

● When Input type (RKC communication: XI, Modbus: 00FAH) is changed

The following communication data will be changed to factory default values according to the new setting.

Name	Factory set value
Gain setting	Factory set value varies depending on the type of input.
	Our CZ-100P/CZ-200P (Standard): 1.500
	Our CZ-100P/CZ-200P (Explosionproof): 1.500
	Our CZ-100P/CZ-200P (Standard) [Loose nut: 0.0 to 0.5 MPa, Fixed nut: 0 to 5 MPa]: 0.650
	Our CZ-100P/CZ-200P (Explosionproof) [Loose nut: 0.0 to 0.5 MPa, Fixed nut: 0 to 5 MPa]: 0.650 3.33 mV/V output type (Pressure sensor made by other companies): 3.330
Display unit	1 (MPa)
Input decimal point position	0 (No decimal place)
Pressure display high	50
Pressure display low	0
PV bias	0
PV ratio	1.000
Alarm 1 set value	50
Alarm 2 set value	0
Alarm 3 set value	50
Alarm 4 set value	50
Input error determination point (high)	53
Input error determination point (low)	-2
Burnout direction	0 (Upscale)
Transmission output scale high	50
Transmission output scale low	0
Alarm 1 hold action to Alarm 4 hold action	0 (OFF)
Alarm 1 interlock to Alarm 4 interlock	0 (Unused, OFF)
Alarm 1 energized/de-energized to Alarm 4 energized/de-energized	0 (Energized)
Alarm 1 differential gap to Alarm 4 differential gap	2
Alarm 1 delay timer to Alarm 4 delay timer	0.0 second

■ **The communication data which will be initialized if the Display unit is changed**

● **When Display unit (RKC communication: PU, Modbus: 00FCH) is changed**

The following communication data will be changed to factory default values according to the new setting.

Name	Factory set value
Input decimal point position	0 (No decimal place)
Pressure display high	50
Pressure display low	0
PV bias	0
PV ratio	1.000
Alarm 1 set value	50
Alarm 2 set value	0
Alarm 3 set value	50
Alarm 4 set value	50
Input error determination point (high)	53
Input error determination point (low)	-2
Burnout direction	0 (Upscale)
Transmission output scale high	50
Transmission output scale low	0
Alarm 1 hold action to Alarm 4 hold action	0 (OFF)
Alarm 1 interlock to Alarm 4 interlock	0 (Unused, OFF)
Alarm 1 energized/de-energized to Alarm 4 energized/de-energized	0 (Energized)
Alarm 1 differential gap to Alarm 4 differential gap	2
Alarm 1 delay timer to Alarm 4 delay timer	0.0 second

■ **The communication data which will be initialized if the Alarm type is changed**

● **When Alarm 1 type (RKC communication: XA, Modbus: 0111H) is changed**

The following communication data will be changed to factory default values according to the new setting.

Name	Factory set value
Alarm 1 set value	50 Varies with the setting of the Input decimal point position.
Alarm 1 hold action	0 (OFF)
Alarm 1 interlock	0 (Unused, OFF)
Alarm 1 energized/de-energized	0 (Energized)
Alarm 1 differential gap	2 Varies with the setting of the Input decimal point position.
Alarm 1 delay timer	0.0 second

● **When Alarm 2 type (RKC communication: XB, Modbus: 0118H) is changed**

The following communication data will be changed to factory default values according to the new setting.

Name	Factory set value
Alarm 2 set value	0 Varies with the setting of the Input decimal point position.
Alarm 2 hold action	0 (OFF)
Alarm 2 interlock	0 (Unused, OFF)
Alarm 2 energized/de-energized	0 (Energized)
Alarm 2 differential gap	2 Varies with the setting of the Input decimal point position.
Alarm 2 delay timer	0.0 second

● **When Alarm 3 type (RKC communication: XC, Modbus: 011FH) is changed**

The following communication data will be changed to factory default values according to the new setting.

Name	Factory set value
Alarm 3 set value	50 Varies with the setting of the Input decimal point position.
Alarm 3 hold action	0 (OFF)
Alarm 3 interlock	0 (Unused, OFF)
Alarm 3 energized/de-energized	0 (Energized)
Alarm 3 differential gap	2 Varies with the setting of the Input decimal point position.
Alarm 3 delay timer	0.0 second

● **When Alarm 4 type (RKC communication: XD, Modbus: 0126H) is changed**

The following communication data will be changed to factory default values according to the new setting.

Name	Factory set value
Alarm 4 set value	50 Varies with the setting of the Input decimal point position.
Alarm 4 hold action	0 (OFF)
Alarm 4 interlock	0 (Unused, OFF)
Alarm 4 energized/de-energized	0 (Energized)
Alarm 4 differential gap	2 Varies with the setting of the Input decimal point position.
Alarm 4 delay timer	0.0 second

■ **The communication data which will be automatically converted if the Input decimal point position is changed**

The following parameters will automatically converted when changing Input decimal point position (RKC communication: XU, Modbus: 00FDH).

Name
Measured value (PV)
Peak hold monitor
Bottom hold monitor
Pressure display high
Pressure display low
PV bias
Alarm 1 set value to Alarm 6 set value
Input error determination point (high)
Input error determination point (low)
Transmission output scale high
Transmission output scale low
Alarm 1 differential gap to Alarm 6 differential gap



The Modbus protocol does not recognize data with decimal points during communication.

Example: When Pressure display high is 105.0 MPa.

105.0 is processed as 1050,

1050 = 041AH

Pressure display high	High	04H
	Low	1AH

■ **The communication data which will be automatically converted if the Gain setting decimal point position is changed**

The following parameters will automatically converted when changing Gain setting decimal point position (RKC communication: GS, Modbus: 010BH).

Name
Gain setting

■ **The communication data which will be automatically converted if the Pressure display high/low are changed**

When the data of Pressure display high (RKC communication: XV, Modbus: 00FEH) or the data of Pressure display low (RKC communication: XW, Modbus: 00FFH) is attempted to set outside of the setting range, these values (high or low) will be set to the Pressure display high (or Pressure display low).

In case the set value goes over the setting range: Set to the Pressure display high.

In case the set value goes below the setting range: Set to the Pressure display low.

Name	Data range
PV bias	-Input span to +Input span
Alarm 1 set value to Alarm 4 set value	Pressure display low to Pressure display high
Input error determination point (high)	Pressure display low - (5 % of input span) to Pressure display high + (5 % of input span)
Input error determination point (low)	Pressure display low - (5 % of input span) to Pressure display high + (5 % of input span)
Transmission output scale high	Transmission output scale low to Pressure display high
Transmission output scale low	Pressure display low to Transmission output scale high
Alarm 1 differential gap to Alarm 4 differential gap	0 to Input span

6. TROUBLESHOOTING



WARNING

- To prevent electric shock or instrument failure, always turn off the system power before replacing the instrument.
- To prevent electric shock or instrument failure, always turn off the power before mounting or removing the instrument.
- To prevent electric shock or instrument failure, do not turn on the power until all wiring is completed. Make sure that the wiring is correct before applying power to the instrument.
- To prevent electric shock or instrument failure, do not touch the inside of the instrument.
- All wiring must be performed by authorized personnel with electrical experience in this type of work.

CAUTION

All wiring must be completed before power is turned on to prevent electric shock, instrument failure, or incorrect action. The power must be turned off before repairing work for input break and output failure including replacement of sensor, contactor or SSR, and all wiring must be completed before power is turned on again.

This section lists some of the main causes and solutions for communication problems.

If you can not solve a problem, please contact RKC sales office or the agent, on confirming the type name and specifications of the product.

■ RKC communication

Problem	Possible cause	Solution
No response	Wrong connection, no connection or disconnection of the communication cable	Confirm the connection method or condition and connect correctly
	Breakage, wrong wiring, or imperfect contact of the communication cable	Confirm the wiring or connector and repair or replace the wrong one
	Mismatch of the setting data of communication speed and data bit configuration with those of the host computer	Confirm the settings and set them correctly
	Wrong address setting	
	The communication settings (device address, communication speed, data bit configuration, etc.) were not enabled after being changed.	After all communication parameters are set, the PG500 power is turned on again after turning it off once.
	Error in the data format	Re-examine the communication program
	Transmission line is not set to the receive state after data send (for RS-485)	

Continued on the next page.

Continued from the previous page.

Problem	Possible cause	Solution
EOT return	The specified identifier is invalid	Confirm the identifier is correct or that with the correct function is specified. Otherwise correct it
	Error in the data format	Reexamine the communication program
NAK return	Error occurs on the line (parity bit error, framing error, etc.)	Confirm the cause of error, and solve the problem appropriately. (Confirm the transmitting data, and resend data)
	BCC error	
	The data exceeds the setting range	Confirm the setting range and transmit correct data
	The specified identifier is invalid	Confirm the identifier is correct or that with the correct function is specified. Otherwise correct it

■ Modbus

Problem	Possible cause	Solution
No response	Wrong connection, no connection or disconnection of the communication cable	Confirm the connection method or condition and connect correctly
	Breakage, wrong wiring, or imperfect contact of the communication cable	Confirm the wiring or connector and repair or replace the wrong one
	Mismatch of the setting data of communication speed and data bit configuration with those of the host computer	Confirm the settings and set them correctly
	Wrong address setting	
	The communication settings (device address, communication speed, data bit configuration, etc.) were not enabled after being changed.	After all communication parameters are set, the PG500 power is turned on again after turning it off once.
	A transmission error (overrun error, framing error, parity error or CRC-16 error) is found in the query message	Re-transmit after time-out occurs or verify communication program
	The time interval between adjacent data in the query message is too long, exceeding 24-bit time	
Error code 1	Function cod error (Specifying nonexistent function code)	Confirm the function code
Error code 2	When the mismatched address is specified.	Confirm the address of holding register
Error code 3	When the specified number of data items in the query message exceeds the maximum number of data items available	Confirm the setting data
Error code 4	Self-diagnostic error	Turn off the power to the instrument. If the same error occurs when the power is turned back on, please contact RKC sales office or the agent.

7. ASCII 7-BIT CODE TABLE

This table is only for use with RKC communication.

					b7	0	0	0	0	1	1	1	1
					b6	0	0	1	1	0	0	1	1
					b5	0	1	0	1	0	1	0	1
b5 to b7	b4	b3	b2	b1		0	1	2	3	4	5	6	7
	0	0	0	0	0	NUL	DLE	SP	0	@	P	'	p
	0	0	0	1	1	SOH	DC1	!	1	A	Q	a	q
	0	0	1	0	2	STX	DC2	”	2	B	R	b	r
	0	0	1	1	3	ETX	DC3	#	3	C	S	c	s
	0	1	0	0	4	EOT	DC4	\$	4	D	T	d	t
	0	1	0	1	5	ENQ	NAK	%	5	E	U	e	u
	0	1	1	0	6	ACK	SYM	&	6	F	V	f	v
	0	1	1	1	7	BEL	ETB	'	7	G	W	g	w
	1	0	0	0	8	BS	CAN	(8	H	X	h	x
	1	0	0	1	9	HT	EM)	9	I	Y	i	y
	1	0	1	0	A	LF	SUB	*	:	J	Z	j	z
	1	0	1	1	B	VT	ESC	+	;	K	[k	{
	1	1	0	0	C	FF	FS	,	<	L	¥	l	
	1	1	0	1	D	CR	GS	-	=	M]	m	}
	1	1	1	0	E	SO	RS	.	>	N	^	n	~
	1	1	1	1	F	SI	US	/	?	O	_	o	DEL

MEMO



RKC INSTRUMENT INC.

HEADQUARTERS: 16-6, KUGAHARA 5-CHOME, OHTA-KU TOKYO 146-8515 JAPAN

PHONE: 03-3751-9799 (+81 3 3751 9799)

FAX: 03-3751-8585 (+81 3 3751 8585)

E-mail: info@rkcinst.co.jp

Website: <http://www.rkcinst.com/>