



Resin Pressure Digital Controller

HA430/HA930

Operation Manual

- Modbus is a registered trademark of Schneider Electric.
- DeviceNet is a registered trademark of Open DeviceNet Vender Association, Inc.
- CC-Link is a registered trademark of Mitsubishi Electric Co. Ltd.
- Company names and product names used in this manual are the trademarks or registered trademarks of the respective companies.

Thank you for purchasing this RKC product. In order to achieve maximum performance and ensure proper operation of the instrument, carefully read all the instructions in this manual. Please place the manual in a convenient location for easy reference.

NOTICE

- This manual assumes that the reader has a fundamental knowledge of the principles of electricity, process control, computer technology and communications.
- The figures, diagrams and numeric values used in this manual are only for explanation purpose.
- RKC is not responsible for any damage or injury that is caused as a result of using this instrument, instrument failure or indirect damage.
- RKC is not responsible for any damage and/or injury resulting from the use of instruments made by imitating this instrument.
- Periodic maintenance is required for safe and proper operation of this instrument. Some components have a limited service life, or characteristics that change over time.
- Every effort has been made to ensure accuracy of all information contained herein. RKC makes no warranty expressed or implied, with respect to the accuracy of the information. The information in this manual is subject to change without prior notice.
- No portion of this document may be reprinted, modified, copied, transmitted, digitized, stored, processed or retrieved through any mechanical, electronic, optical or other means without prior written approval from RKC.



WARNING

- To prevent injury to persons, damage to the instrument and the equipment, a suitable external protection device shall be required.
- All wiring must be completed before power is turned on to prevent electric shock, fire or damage to the instrument and the equipment.
- This instrument must be used in accordance with the specifications to prevent fire or damage to the instrument and the equipment.
- This instrument is not intended for use in locations subject to flammable or explosive gases.
- Do not touch high-voltage connections such as power supply terminals, etc. to avoid electric shock.
- RKC is not responsible if this instrument is repaired, modified or disassembled by other than factory-approved personnel. Malfunction may occur and warranty is void under these conditions.

CAUTION

- This product is intended for use with industrial machines, test and measuring equipment. (It is not designed for use with medical equipment and nuclear energy plant.)
- This is a Class A instrument. In a domestic environment, this instrument may cause radio interference, in which case the user may be required to take additional measures.
- This instrument is protected from electric shock by reinforced insulation. Provide reinforced insulation between the wire for the input signal and the wires for instrument power supply, source of power and loads.
- Be sure to provide an appropriate surge control circuit respectively for the following:
 - If input/output or signal lines within the building are longer than 30 meters.
 - If input/output or signal lines leave the building, regardless the length.
- This instrument is designed for installation in an enclosed instrumentation panel. All high-voltage connections such as power supply terminals must be enclosed in the instrumentation panel to avoid electric shock to operating personnel.
- All precautions described in this manual should be taken to avoid damage to the instrument or equipment.
- If the equipment is used in a manner not specified by the manufacturer, the protection provided by the equipment may be impaired.
- All wiring must be in accordance with local codes and regulations.
- All wiring must be completed before power is turned on to prevent electric shock, instrument failure, or incorrect action.

The power must be turned off before repairing work for input break and output failure including replacement of sensor, contactor or SSR, and all wiring must be completed before power is turned on again.
- To prevent instrument damage as a result of failure, protect the power line and the input/output lines from high currents with a suitable overcurrent protection device with adequate breaking capacity such as a fuse, circuit breaker, etc.
- A malfunction in this product may occasionally make control operations impossible or prevent alarm outputs, resulting in a possible hazard. Take appropriate measures in the end use to prevent hazards in the event of malfunction.
- Prevent metal fragments or lead wire scraps from falling inside instrument case to avoid electric shock, fire or malfunction.
- Tighten each terminal screw to the specified torque found in the manual to avoid electric shock, fire or malfunction.
- For proper operation of this instrument, provide adequate ventilation for heat dissipation.
- Do not connect wires to unused terminals as this will interfere with proper operation of the instrument.
- Turn off the power supply before cleaning the instrument.
- Do not use a volatile solvent such as paint thinner to clean the instrument. Deformation or discoloration may occur. Use a soft, dry cloth to remove stains from the instrument.
- To avoid damage to the instrument display, do not rub with an abrasive material or push the front panel with a hard object.

FOR PROPER DISPOSAL

- When disposing of each part used for this instrument, always follows the procedure for disposing of industrial wastes stipulated by the respective local community.

DOCUMENT CONFIGURATION

There are seven manuals pertaining to this product. Please be sure to read all manuals specific to your application requirements. If you do not have a necessary manual, please contact RKC sales office, the agent, or download from the official RKC website.

Manual	Manual Number	Remarks
HA430/HA930 Instruction Manual ¹	IMR01N11-E□	This manual is enclosed with instrument. This manual explains the mounting and wiring, front panel name, and the operation mode outline.
HA430/HA930 Operation Manual ¹	IMR01N12-E7	This Manual. This manual explains the method of the mounting and wiring, the operation of various functions, and troubleshooting.
HA430/HA930 Communication Instruction Manual ^{1, 2} [RKC communication/MODBUS]	IMR01N13-E□	This manual explains RKC communication protocol, Modbus, and relating to the communication parameters setting.
HA430/HA930 Communication Instruction Manual ^{1, 2} [PROFIBUS]	IMR01N14-E□	This manual explains PROFIBUS communication connection and configuration.
HA430/HA930 Communication Instruction Manual ^{1, 2} [DeviceNet]	IMR01N15-E□	This manual explains DeviceNet communication connection and node address setting.
HA430/HA930 Communication Instruction Manual ^{1, 2} [CC-Link]	IMR01N21-E□	This manual explains CC-Link communication connection and relating to the communication parameters setting.
HA430/HA930 Quick Operation Manual ^{1, 2}	IMR01N16-E□	Describes procedures from initial settings (zero/full scale adjustment, PI constant setting, etc.) necessary for performing pressure control to operation.
Infrared Communication Software RKCIR for HA Series Controller PDA INSTALL GUIDE	IMT01C01-E□	This manual describes downloading of the "RKCIR infrared communication software" and installation of this software to the PDA.

¹ The above manuals can be downloaded from the official RKC website:
http://www.rkcinst.com/english/manual_load.htm.

² Optional function



Read this manual carefully before operating the instrument. Please place the manual in a convenient location for easy reference.

SYMBOLS

● Safety Symbols

WARNING : This mark indicates precautions that must be taken if there is danger of electric shock, fire, etc., which could result in loss of life or injury.

CAUTION : This mark indicates that if these precautions and operating procedures are not taken, damage to the instrument may result.



: This mark indicates that all precautions should be taken for safe usage.



: This mark indicates important information on installation, handling and operating procedures.



: This mark indicates supplemental information on installation, handling and operating procedures.



: This mark indicates where additional information may be located.

● Character Symbols

0	1	2	3	4	5	6	7	8	9	Minus	Period
0	1	2	3	4	5	6	7	8	9	-	.
A	B (b)	C	D (d)	E	F	G	H	I	J	K	L
A	b	C	d	E	F	G	H	I	J	K	L
M	N (n)	O (o)	P	Q (q)	R (r)	S	T	t	U	u	V
m̄	n	o	P	q	r	S	T	t	U	u	V
W	X	Y	Z	Degree	/						
W	X	Y	Z	°	/						

● Character LED lighting state:



: Dim lighting



: Bright lighting



: Flashing

● Pressure units (conversion)

$$1 \text{ MPa} = 10 \text{ bar} = 10.1972 \text{ kgf/cm}^2 = 145.038 \text{ psi}$$

CONTENTS

	Page
1. OUTLINE	1
1.1 Checking the Product	1
1.2 Model Code	2
1.3 Input/Output Functions	4
1.4 Parts Description	7
2. MOUNTING	10
2.1 Mounting Cautions.....	10
2.2 Dimensions.....	11
■ HA430	11
■ HA930	11
2.3 Procedures of Mounting and Removing	12
■ Mounting procedures.....	12
■ Removing procedures	12
3. WIRING	13
3.1 Wiring Cautions	13
3.2 Terminal Layout.....	14
■ HA430	14
■ HA930	14
3.3 Wiring of Each Terminal	15
■ Power supply	15
■ Output 1 to 3 (OUT1 to OUT3)	16
■ Output 4 to 5 (OUT4 to OUT5)	16
■ Input 1 (pressure sensor input).....	17
■ Input 1 (voltage and current inputs).....	18
■ Input 2 (thermocouple, RTD, voltage, and current inputs).....	19
■ Remote input (optional)	19
■ Event input (optional).....	19
■ Sensor power supply (optional)	20
■ Communication (optional).....	20

	Page
4. SETTING	22
4.1 Setting Procedure to Operation	22
4.2 Operation Menu	24
■ Input type and input range display	25
4.3 Key Operation	26
■ Scrolling through parameters	26
■ Changing Set value (SV)	26
■ Data lock function	27
■ How to restrict operation of the direct keys	27
4.4 Changing Parameter Settings	28
■ Change settings	28
5. SV SETTING & MONITOR MODE	30
5.1 Display Sequence	30
5.2 Procedure for Set Value (SV) Setting	31
6. PARAMETER SETTING MODE	32
6.1 Display Sequence	32
6.2 Parameter List	34
6.3 Description of Each Parameter	35
■ Event 1 set value (EV1)/Event 2 set value (EV2)/Event 3 set value (EV3)/ Event 4 set value (EV4)	35
■ Control loop break alarm (LBA) time (LbA1, LbA2)	35
■ LBA deadband (Lbd1, Lbd2)	36
■ Proportional band (1. P, 2. P) for PI/PID control	37
■ Integral time (1. I, 2. I) for PI/PID control	37
■ Derivative time (1. d, 2. d) for PID control	37
■ Control response parameter (1. rPT, 2. rPT)	38
■ Setting change rate limiter (up) (1.SVrU, 2.SVrU)	38
■ Setting change rate limiter (down) (1.SVrd, 2.SVrd)	39
■ Area soak time (AST)	40
■ Link area number (LnKA)	41

	Page
7. SETUP SETTING MODE	42
7.1 Display Sequence.....	42
7.2 Parameter List	43
7.3 Description of Each Parameter.....	44
■ PV bias (1. Pb, 2. Pb).....	44
■ PV digital filter (1. dF, 2. dF).....	44
■ PV ratio (1. Pr, 2. Pr)	44
■ PV low input cut-off (1. PLC, 2. PLC)	45
■ Proportional cycle time (1. T, 2. T)	45
■ Device address (Slave address) (Add2)	46
■ Communication speed (bPS2).....	46
■ Data bit configuration (bIT2).....	46
■ Interval time (InT2)	47
■ Infrared communication address (Add3)	47
■ Infrared communication speed (bPS3)	47
■ Auto-zero (AZEr)	48
■ Auto calibration (ACAL).....	49
■ Set lock level (LCK).....	49
8. ENGINEERING MODE	50
8.1 Display Sequence.....	50
8.2 Parameter List	54
8.3 Precaution Against Parameter Change	58
8.4 Screen Configuration (F10)	63
■ STOP display selection (SPCH).....	63
■ Bar graph display selection (dE).....	63
■ Bar graph resolution setting (dEUT)	64
■ Decimal point position of MV scaling (MVdP).....	64
■ MV scaling high (MVHS)	64
■ MV scaling low (MVLS)	65
8.5 Direct key (F11)	65
■ Auto/Manual transfer key operation selection (Fn1).....	65
■ Remote/Local transfer key operation selection (Fn2).....	65
■ RUN/STOP transfer key operation selection (Fn3)	65
8.6 Input 1 (F21)/Input 2 (F22).....	66
■ Input type selection (1. InP, 2. InP)	66
■ Display unit selection (1. UnIT, 2. UnIT).....	67
■ Gain setting (GAln) [F21].....	67

	Page
■ Linearize type (LInS) [F21]	68
■ Shunt resistance output value (SHnT) [F21]	69
■ Decimal point position (1. PGdP, 2. PGdP).....	69
■ Input scale high (1. PGSH, 2. PGSH).....	69
■ Input scale low (1. PGSL, 2. PGSL)	70
■ Input error determination point (high) (1. PoV, 2. PoV).....	70
■ Input error determination point (low) (1. PUn, 2. PUn).....	71
■ Burnout direction (1. boS, 2. boS)	71
■ Square root extraction selection (1. SQr, 2. SQr).....	72
■ PV hold function (1. HLdS, 2. HLdS).....	72
■ Power supply frequency selection (PFRQ).....	72
8.7 Event Input (F23).....	73
■ Event input logic selection (dISL)	73
8.8 Output (F30)	76
■ Output logic selection (LoGC)	76
■ Output timer setting (oTT1 to oTT5).....	77
■ Alarm lamp lighting condition setting (ALC1, ALC2) *	77
■ Interlock function (oTIL).....	78
* The setting item "ALC2" is not used in the HA430/930.	
8.9 Transmission Output 1 (F31)/ Transmission Output 2 (F32)/ Transmission Output 3 (F33).....	79
■ Transmission output type selection (Ao1, Ao2, Ao3).....	79
■ Transmission output scale high (AHS1, AHS2, AHS3)	79
■ Transmission output scale low (ALS1, ALS2, ALS3).....	79
8.10 Event 1 (F41)/Event 2 (F42)/Event 3 (F43)/Event 4 (F44)	80
■ Event type selection (ES1, ES2, ES3, ES4).....	80
■ Event hold action (EHo1, EHo2, EHo3, EHo4).....	82
■ Event differential gap (EH1, EH2, EH3, EH4)	83
■ Event action at input error (EEo1, EEo2, EEo3, EEo4).....	84
■ Event assignment (EVA1, EVA2, EVA3, EVA4).....	84
8.11 Control (F50) *	85
■ Hot/Cold start selection (Pd).....	85
■ Input 2_use selection (CAM)	85
■ SV tracking (TrK)	86
* The setting items "CAr" and "CAb" are not used in the HA430/930.	

	Page
8.12 Control 1 (F51) * /Control 2 (F52) *	87
■ Control action type selection (1. oS, 2. oS)	87
■ Integral/Derivative time decimal point position (1.IddP, 2.IddP)	87
■ Derivative gain (1. dGA, 2.dGA)	87
■ ON/OFF action differential gap (upper) (1. oHH, 2. oHH)	88
■ ON/OFF action differential gap (lower) (1. oHL, 2. oHL)	88
■ Action at input error (high) (1.AoVE, 2.AoVE)	89
■ Action at input error (low) (1.AUnE, 2.AUnE)	89
■ Manipulated output value at input error (1. PSM, 2. PSM)	90
■ Manipulated output value when transferred Auto from Manual (1. PSM', 2. PSM')	90
■ Output change rate limiter (up) (1. orU, 2. orU)	90
■ Output change rate limiter (down) (1. ord, 2. ord)	91
■ Output limiter high (1. oLH, 2. oLH)	92
■ Output limiter low (1. oLL, 2. oLL)	92
■ MV transfer function (1. MVTS, 2. MVTS)	92
* The setting items "1.PFF," "1.PFFS," "2.PFF" and "2.PFFS" are not used in the HA430/930.	
8.13 Autotuning 1 (AT1) (F53) /Autotuning 2 (AT2) (F54)	93
■ AT bias (1. ATb, 2. ATb)	93
■ AT cycle (1. ATC, 2. ATC)	94
■ AT differential gap time (1. ATH, 2. ATH)	95
■ AT action (1. ATt, 2. ATt)	96
8.14 Communication Function (F60) *	97
■ Communication protocol selection (CMPS2)	97
* The setting item "CMPS1" is not used in the HA430/930.	
8.15 Set Value (SV) (F70)	97
■ Setting change rate limiter unit time (SVrT)	97
■ Soak time unit selection (STdP)	97
8.16 Set Value 1 (SV1) (F71) /Set Value 2 (SV2) (F72)	98
■ Setting limiter high (1. SLH, 2. SLH)	98
■ Setting limiter low (1. SLL, 2. SLL)	98
■ PV transfer function (1. PVTS, 2. PVTS)	98
8.17 System Information Display (F91)	99

9. OPERATION 100

9.1 Control RUN and STOP	100
■ Operation under control RUN mode	100
■ Display at control STOP	100
9.2 Configuration of Operation Mode	101

	Page
9.3 Monitoring Display in Operation.....	102
9.4 Auto/Manual Transfer	108
■ Auto/Manual transfer by Front key operation	108
■ Auto/Manual transfer by Direct key (A/M) operation.....	109
■ Auto/Manual transfer by Event input	109
■ Procedure for setting the Manipulated output value (MV) in Manual mode.....	110
■ Manipulated output value (MV) under Manual control is changed by event input	110
9.5 Remote/Local Transfer	111
■ Remote/Local transfer by Front key operation	111
■ Remote/Local transfer by Direct key (R/L) operation	111
■ Remote/Local transfer by Event input	112
9.6 RUN/STOP Transfer.....	112
■ RUN/STOP transfer by Front key operation	112
■ RUN/STOP transfer by Direct key (R/S) operation.....	113
■ RUN/STOP transfer by Event input	113
9.7 Control Area Transfer	114
■ Control area transfer by Front key operation.....	114
■ Control area transfer by Event input.....	114
9.8 Start Action at Recovering Power Failure	115
9.9 Ramp/Soak Control	116
10. ERROR DISPLAY	120
10.1 Over-scale and Underscale	120
10.2 Self-diagnostic Error	121
11. TROUBLESHOOTING	122
11.1 Display.....	122
11.2 Control.....	123
11.3 Operation.....	124
11.4 Other	125
12. REMOVING THE INTERNAL ASSEMBLY	126

	Page
APPENDIX	
A. Setting Data List	A-1
A-1. SV setting & Monitor mode	A-1
A-2. Setup setting mode	A-2
A-3. Parameter setting mode.....	A-5
A-4. Engineering mode (F10 to F91)	A-7
B. Specifications.....	A-24
C. Memory Area Data List.....	A-29
INDEX	B-1

MEMO

1. OUTLINE

This chapter describes features, package contents and model code, etc. The HA430/930 Series controllers are ideal to control resin pressure with its standard strain gauge input and 24 V DC transmitter power supply. The resin pressure digital controller of this high performance type has the following features:

■ High-speed sampling time (25 ms)

Suitable for fast responding control systems.

■ Pressure and Temperature control with a single instrument

The HA430/930 provide dual loop control with a single instrument. The first loop is assigned to a strain gauge input and the second loop to a temperature input (TC, RTD, Voltage, or Current).

■ Easy zero and full scale adjustments

Zero and full scale adjustments of the pressure measured value are available from the front panel.

■ Direct function keys

Three Direct function keys on the front panel are provided for one-key operation to switch Auto/Manual, Remote/Local, and RUN/STOP.

■ Up to 16 memory areas or Ramp/Soak control

HA430/930 can store up to 16 sets of control parameters. Ramp/Soak control is available by using the memory area function.

■ Waterproof/Dustproof (standard)

The front panel has a waterproof, dustproof construction equivalent to IP65.

■ Communication port (optional)

Communication function can be selected from serial communication (RS-232C, RS-422A, RS-485) and Open Network (PROFIBUS, DeviceNet, CC-Link).

■ Sensor power supply (optional)

Sensor power supply is used to supply power to pressure sensor with amplifier or 2-wire pressure transmitter (however, the number of output points is limited).

1.1 Checking the Product

Before using this product, check each of the following:

- Model code
- Check that there are no scratch or breakage in external appearance (case, front panel, or terminal, etc).
- Check that all of the items delivered are complete. (Refer to below)

Accessories	Q'TY	Remarks	
<input type="checkbox"/> Instrument	1	_____	
<input type="checkbox"/> Mounting brackets	Each 2	HA930: each 4	
<input type="checkbox"/> Instruction Manual (IMR01N11-E□)	1	Enclosed with instrument	
<input type="checkbox"/> Operation Manual (IMR01N12-E7)	1	This Manual (sold separately)	This manual can be downloaded from the official RKC website: http://www.rkcinst.com/english/manual_load.htm .
<input type="checkbox"/> Quick Operation Manual (IMR01N16-E□)	1	_____	
<input type="checkbox"/> Communication Instruction Manual (IMR01N13-E□) [RKC communication/Modbus]	1	Optional (sold separately)	
<input type="checkbox"/> Communication Instruction Manual (IMR01N14-E□) [PROFIBUS]	1	Optional With PROFIBUS	
<input type="checkbox"/> Communication Instruction Manual (IMR01N15-E□) [DeviceNet]	1	Optional With DeviceNet	
<input type="checkbox"/> Communication Instruction Manual (IMR01N21-E□) [CC-Link]	1	Optional With CC-Link	
<input type="checkbox"/> PDA Install Guide (IMT01C01-E□)	1	Infrared communication software "RKCIR"	

 If any of the products are missing, damaged, or if your manual is incomplete, please contact RKC sales office or the agent.

1.2 Model Code

Check whether the delivered product is as specified by referring to the following model code list. If the product is not identical to the specifications, please contact RKC sales office or the agent.

HA430 - - - * - - /Y
HA930 (1) (2) (3) (4) (5) (6) (7) (8) (9) (10) (11)

(1) Input 1 type

H : Resin pressure sensor CZ-100P, CZ-200P (RKC product)

X : Resin pressure sensor (Strain gauge type)¹ other than RKC product

3 : Voltage (low) input group (0 to 10 mV, 0 to 100 mV, 0 to 1 V, ±10 mV, ±100 mV) [Factory set value: 0 to 1 V]²

6 : Voltage (high) input group (0 to 5 V, 1 to 5 V, 0 to 10 V, ±1 V, ±5 V, ±10 V) [Factory set value: 1 to 5 V]²

8 : Current input group (0 to 20 mA, 4 to 20 mA) [Factory set value: 4 to 20 mA]²

¹ Rated output: 0.500 to 4.000 mV/V Maximum supply voltage: More than 8 V DC

² To change the input type, refer to **8. ENGINEERING MODE. (P. 50)**

(2) Input 2 type

0: None

K : K thermocouple J : J thermocouple T : T thermocouple S : S thermocouple R : R thermocouple

A : PLII thermocouple N : N thermocouple E : E thermocouple B : B thermocouple W : W5Re/W26Re

D : RTD (3-wire) [Factory set value: Pt100]

3 : Voltage (low) input group (0 to 10 mV, 0 to 100 mV, 0 to 1 V, ±10 mV, ±100 mV) [Factory set value: 0 to 1 V]^{*}

6 : Voltage (high) input group (0 to 5 V, 1 to 5 V, 0 to 10 V, ±1 V, ±5 V, ±10 V) [Factory set value: 1 to 5 V]^{*}

8 : Current input group (0 to 20 mA, 4 to 20 mA) [Factory set value: 4 to 20 mA]^{*}

Non-isolated type (for remote input)

G : Voltage (low) input group (0 to 10 mV, 0 to 100 mV, 0 to 1 V, ±10 mV, ±100 mV) [Factory set value: 0 to 1 V]^{*}

V : Voltage (high) input group (0 to 5 V, 1 to 5 V, 0 to 10 V, ±1 V, ±5 V, ±10 V) [Factory set value: 1 to 5 V]^{*}

Y : Current input group (0 to 20 mA, 4 to 20 mA) [Factory set value: 4 to 20 mA]^{*}

^{*} To change the input type, refer to **8. ENGINEERING MODE. (P. 50)**

(3) Output 1 (OUT1)

N : None

T : Triac output

6 : Voltage output (1 to 5 V DC)

M : Relay contact output

4 : Voltage output (0 to 5 V DC)

7 : Current output (0 to 20 mA DC)

V : Voltage pulse output

5 : Voltage output (0 to 10 V DC)

8 : Current output (4 to 20 mA DC)

Continued on the next page.

(4) Output 2 (OUT2)

N : None	T : Triac output	6 : Voltage output (1 to 5 V DC)
M : Relay contact output	4 : Voltage output (0 to 5 V DC)	7 : Current output (0 to 20 mA DC)
V : Voltage pulse output	5 : Voltage output (0 to 10 V DC)	8 : Current output (4 to 20 mA DC)

(5) Power supply voltage

3 : 24 V AC/DC	4 : 100 to 240 V AC
----------------	---------------------

(6) Output 3 (OUT3)

N : None	T : Triac output	6 : Voltage output (1 to 5 V DC)
M : Relay contact output	4 : Voltage output (0 to 5 V DC)	7 : Current output (0 to 20 mA DC)
V : Voltage pulse output	5 : Voltage output (0 to 10 V DC)	8 : Current output (4 to 20 mA DC)
P : Sensor power supply *		

* If Sensor power supply is specified, OUT4 and OUT5 code becomes "N."

(7) Output 4 (OUT4)/Output 5 (OUT5) *

N : None	
1 : OUT4 (Relay contact output)	OUT5 (No output)
2 : OUT4 (Relay contact output)	OUT5 (Relay contact output)

* If Sensor power supply is specified, OUT4 and OUT5 code becomes "N."

(8) Event input (optional)

N : None
1 : Event input [Dry contact input (5 points): for Memory area selection, Operation mode transfer, etc.]

(9) Communication (optional)

N : None	6 : RS-485 (Modbus)	A : DeviceNet
1 : RS-232C (RKC communication)	7 : RS-422A (Modbus)	B : PROFIBUS
4 : RS-422A (RKC communication)	8 : RS-232C (Modbus)	C : CC-Link
5 : RS-485 (RKC communication)		

(10) Case color

N : White	A : Black
-----------	-----------

(11) Instrument version

Y : Version symbol (Infrared communication function included)

1.3 Input/Output Functions

This section describes the input/output functions of the instrument. To learn how to set each function, refer to the respective page.

■ INPUT

In addition to measured input, 2 optional input functions are available.

Measured input:

- Input 1 can be used for pressure sensor input or voltage/current input. (Specify when ordering)
- Input 2 can be used for temperature input or voltage/current input. (Specify when ordering)

Input 1	Pressure sensor input	Resin pressure sensor (0.0 to 250.0 MPa)
Input 2	Thermocouple *	K, J, T, S, R, E, B, PLII, N, W5Re/W26Re
	RTD *	Pt100, JPt100 [Factory set value: Pt100]
Input 1 Input 2	Voltage (low) *	0 to 100 mV DC, 0 to 10 mV DC, 0 to 1 V DC, ±10 mV DC, ±100 mV DC [Factory set value: 0 to 1 V DC]
	Voltage (High) *	0 to 5 V DC, 1 to 5 V DC, DC 0 to 10 V DC, ±1 V DC, ±5 V DC, ±10 V DC [Factory set value: 1 to 5 V DC]
	Current *	0 to 20 mA DC, 4 to 20 mA DC [Factory set value: 4 to 20 mA DC]

* To change the input type, refer to **8. ENGINEERING MODE. (P. 50)**

- The second measured input can be used as non-isolated remote input.

Event input:

- Optional Event input hardware is necessary. (Specify when ordering)
- Event input can be used for the following functions. (Refer to P. 73.)

Memory area selection (Number of areas: 1 to 16 or 1 to 8),
Operation mode transfer (RUN/STOP, Remote/Local, Auto/Manual.),
Hold reset, Interlock release,
Manual output up/down (Motor RPM up/down), Manual output 0 % reset (Motor RPM reset)

Remote input (non-isolated type):

- Remote input is to change a control setpoint by using current or voltage input from an external device.
- Remote input is available with Input 2. (Specify when ordering)
- Any one of the following input types can be selected. (Refer to P. 66.)

Voltage (low)	0 to 100 mV DC, 0 to 10 mV DC, 0 to 1 V DC, ±10 mV DC, ±100 mV DC
Voltage (High)	0 to 5 V DC, 1 to 5 V DC, DC 0 to 10 V DC, ±1 V DC, ±5 V DC, ±10 V DC
Current	0 to 20 mA DC, 4 to 20 mA DC

■ OUTPUT

Up to five outputs are available. They may be used as Control output, Event output or Transmission output by specifying the output type or by activating the output logic function (output logic selection).

Output1 to 3 (OUT1 to OUT3):

- Control output, Event output, or Transmission output can be allocated to output 1 to 3. (Refer to P. 76 to 84.)
- Number of outputs and output types must be specified when ordering.
- Output types available for OUT1 to OUT3 are shown in the table below.

Relay contact output	250 V AC, 3A (Resistive load), 1a contact
Voltage pulse output	0/12 V DC (Load resistance: 600 Ω or more)
Triac output	0.4 A (Allowable load current)
Voltage output	0 to 5 V DC, 1 to 5 V DC, 0 to 10 V DC (Load resistance: 1 kΩ or more)
Current output	0 to 20 mA DC, 4 to 20 mA DC (Load resistance: 600 Ω or less)

- OUT3 is isolated from both OUT1 and OUT2.
- OUT1 and OUT2 are not isolated from each other except for relay or triac output. When relay or triac output is used, there is isolation between outputs.
- There is isolation between input and output.
- There is isolation between output and power supply terminals.
- OUT3 can be selected for Sensor power supply. (Specify when ordering)

Output 4 to 5 (OUT4 to OUT5):

- The output type for OUT4 and OUT5 is relay only. OUT4 and OUT5 can be used for Allowable load vent output. (Refer to P. 76 to 84.)
Relay contact output 250 V AC, 1A (Resistive load), 1a contact
- If the sensor power supply is selected for OUT3, OUT4 and OUT5 cannot be used.

Event output function (EV1 to EV4)

- The following event types can be selected for EV1 to EV4.

Deviation high	Band	SV high	_____
Deviation low	Process high	SV low	_____
Deviation high/low	Process low	LBA (Only EV3 and EV4 can be selected)	

- The maximum number of Event output is four.
- Output allocation is necessary to output the event state from output terminals. (Refer to P. 76.)

Transmission output 1 to 3 (AO1 to AO3):

- Maximum three transmission output can be allocated to OUT1, OUT2, and OUT3. Maximum number of output available for transmission output varies by other output use for control output and event output. Parameter values shown in the following table can be output by transmission output. (Refer to P. 79.)

Input 1 side	Measured value (PV), Set value (SV), Manipulated output value (MV), Deviation (PV-SV)
Input 2 side	Measured value (PV), Set value (SV), Manipulated output value (MV), Deviation (PV-SV)

Output logic function:

Output logic function allocates output functions to output terminals. Logic output such as *OR/AND* is available for event output. The following signals are allocated by output logic function. Transmission output needs to be allocated separately. (Refer to P. 73 to 76.)

Input	Analog signal: Control output value (max. 2 points)
	Digital signal: Event action state (4 points), Contact input state (max. 5 points), Control area number (4 points) Operation state (3 points): LOC/MAN/REM
Output	Computed output from OUT1 to OUT5. ALM LED (1 point)

■ COMMUNICATION**Communication (optional):**

Communication port is available to communicate with a computer or programmable controller. The protocols available for a port is shown in the table below.

Interface *	RS-485, RS-232C, or RS-422A
Protocol *	RKC communication, Modbus
Open Network *	PROFIBUS, DeviceNet, or CC-Link

* Specify when ordering.

Infrared communication:

Infrared communication can be used when sending and receiving data between this controller and the PDA installed with the RKCIR software.

1.4 Parts Description

This section describes various display units and the key functions.

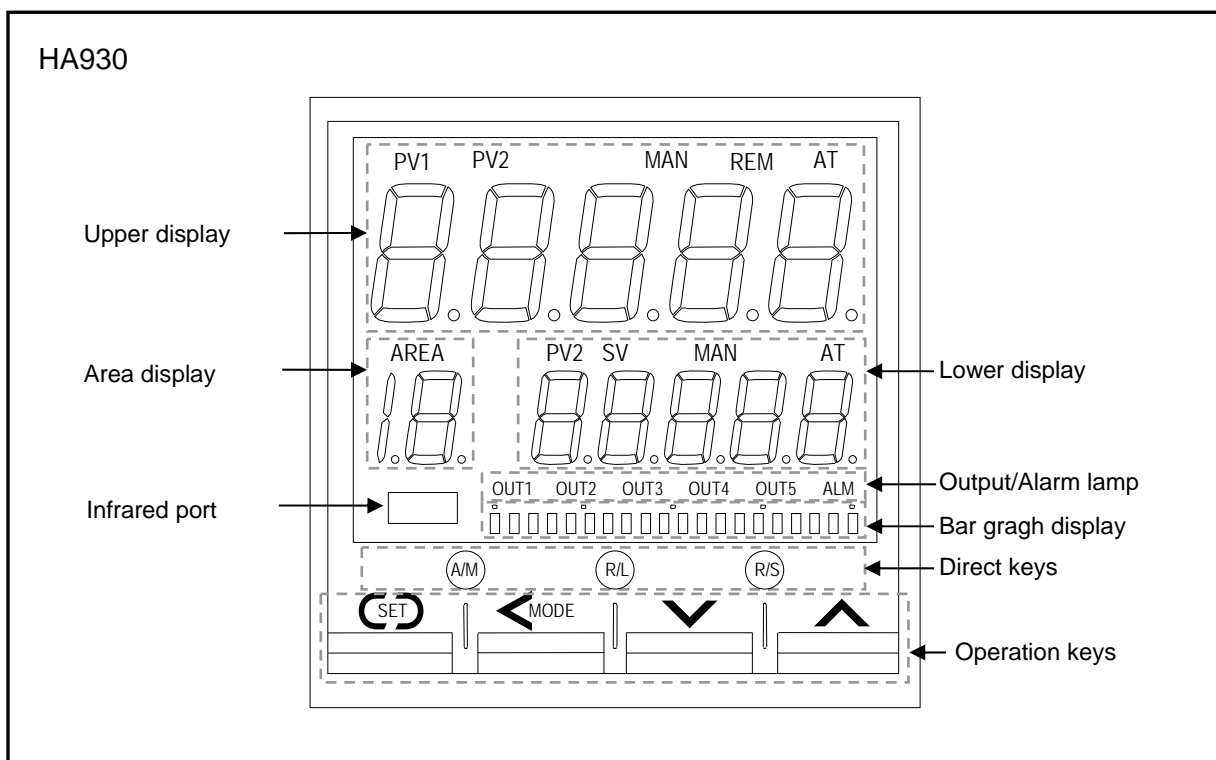
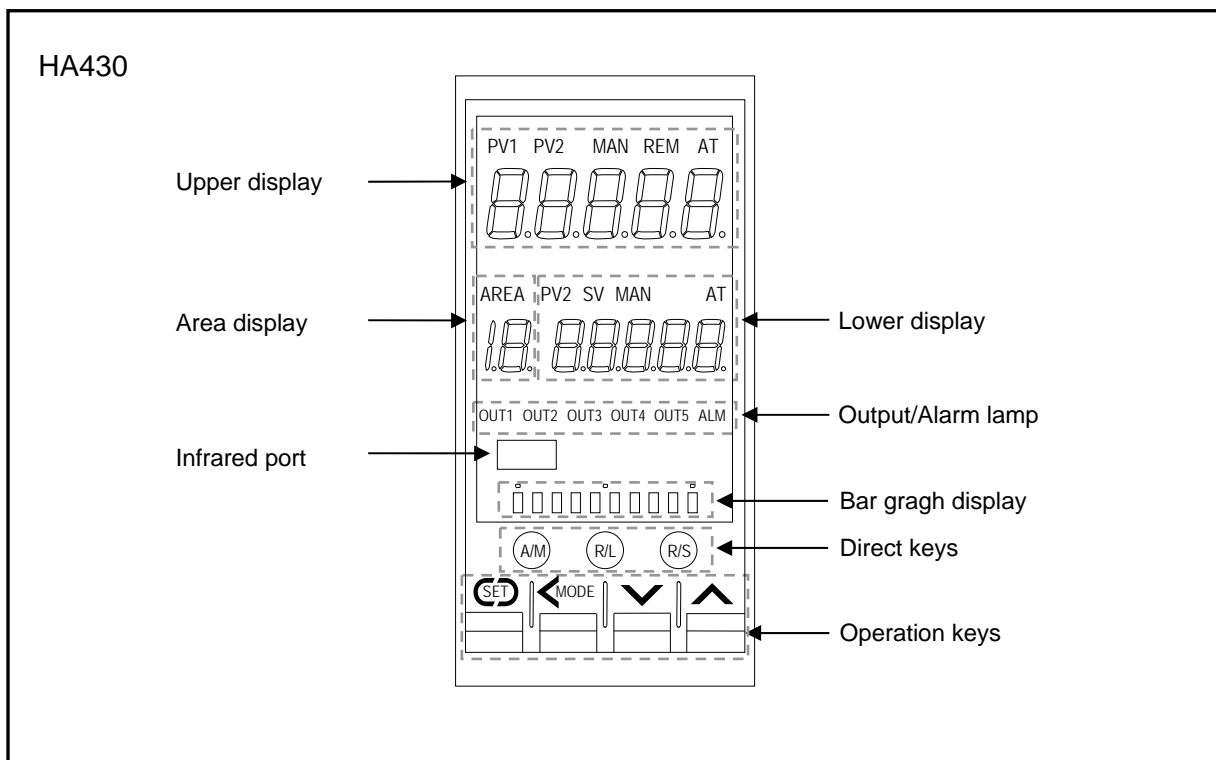

● **Upper display**

Measured value 1 (PV1) lamp [Green]	Lights when measured value 1 is displayed on the PV1/PV2 display unit.
Measured value 2 (PV2) lamp * [Green]	Lights when measured value 2 is displayed on the PV1/PV2 display unit.
Manual (MAN) mode lamp [Green]	Lights when operated in manual mode.
Remote (REM) mode lamp [Green]	Lights when remote setting function is activated.
Autotuning (AT) lamp [Green]	Flashes when autotuning is activated. (After autotuning is completed: AT lamp will go out)
Measured value (PV1/PV2) display	Displays PV1, PV2 or various parameters' symbols.

* This lamp is activated only with 2-input controller.

● **Lower display**

Measured value 2 (PV2) lamp * [Green]	Lights when measured value 2 is displayed on the SV display unit.
Set value (SV) lamp [Green]	Lights when Set value (SV) is displayed on the SV display unit.
Manual (MAN) mode lamp * [Green]	Lights when operated in manual mode.
Autotuning (AT) lamp * [Green]	Flashes when autotuning is activated. (After autotuning is completed: AT lamp will go out)
Set value (SV) display	Displays SV, PV2 or various parameters' set values.

* This lamp is activated only with 2-input controller.

● **Area display**

Area (AREA) lamp [Green]	Lights when memory area number is displayed.
Memory area display	Displays memory area number (1 to 16).



● **Output/Alarm lamp**

Output (OUT1 to OUT5) lamp [Green]	Lights when the output corresponding to each lamp is ON.
Alarm (ALM) lamp [Red]	Lights when alarm (Event function) is turned on. The type of alarm which is on can be checked on the event monitor display.

 These lamps works with outputs (control, alarm, retransmission) which are assigned to OUT1 through OUT5.
For assignment of outputs to OUT1 through OUT5, refer to Output Logic Selection. (P. 76)

● **Bar graph display [Green] ***

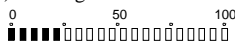
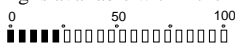

One of the displays shown in the table below can be selected for the bar graph.

Manipulated output value (MV) display	Displays the Manipulated output value (MV). When Manipulated output value (MV) is at 0 % or less, the left-end dot of the bar-graph flashes. When MV exceeds 100 %, the right-end dot flashes. [Example] 
Measured value display	Displays the Measured value (PV). Scaling is available within the input range. [Example] 
Set value display	Displays the Set value (SV). Scaling is available within the input range. [Example] 
Deviation display	Displays the deviation between the Measured value (PV) and the Set value (SV). When the Deviation display is selected, the dots at both ends of bar-graph light. [Example] 

* The number of dots: 10 dots (HA430) 20 dots (HA930)

 Bar graph display can be selected in the Engineering mode. Refer to selecting the bar graph display (P. 63).

● Direct keys

 Auto/Manual transfer key	Switching the Auto/Manual control mode between Auto (PID control) mode and Manual mode.
 Remote/Local transfer key	Switching the Remote/Local control mode between Remote control and Local control.
 RUN/STOP transfer key	Switching the RUN/STOP mode between RUN and STOP.



To avoid damage to the instrument, never use a sharp object to press keys.







For the Auto/Manual transfer key, it is possible to select among Auto/Manual transfer for (1) Input 1, (2) Input 2, or (3) both Input 1 and Input 2. (Refer to P. 65)



Use/Unuse of Direct key functions are programmable. (Refer to P. 65)

● Operation keys

 Set (SET) key	Used for calling up parameters and set value registration.
 Shift key	Shifts digits when settings are changed. Used to selection operation between modes.
 Down key	Decreases numerals.
 Up key	Increases numerals.



To avoid damage to the instrument, never use a sharp object to press keys.

● Infrared port

Used when sending and receiving data between this controller and the PDA installed with the RKCIR software.

2. MOUNTING

This chapter describes installation environment, mounting cautions, dimensions and mounting procedures.



WARNING

To prevent electric shock or instrument failure, always turn off the power before mounting or removing the instrument.

2.1 Mounting Cautions

- (1) This instrument is intended to be used under the following environmental conditions. **(IEC 61010-1)**
[OVERVOLTAGE CATEGORY II, POLLUTION DEGREE 2]
- (2) Use this instrument within the following environment conditions:
 - Allowable ambient temperature: -10 to +50 °C
 - Allowable ambient humidity: 5 to 95 %RH
(Absolute humidity: MAX. W. C 29 g/m³ dry air at 101.3 kPa)
 - Installation environment conditions: Indoor use
Altitude up to 2000 m
- (3) Avoid the following conditions when selecting the mounting location:
 - Rapid changes in ambient temperature which may cause condensation.
 - Corrosive or inflammable gases.
 - Direct vibration or shock to the mainframe.
 - Water, oil, chemicals, vapor or steam splashes.
 - Excessive dust, salt or iron particles.
 - Excessive induction noise, static electricity, magnetic fields or noise.
 - Direct air flow from an air conditioner.
 - Exposure to direct sunlight.
 - Excessive heat accumulation.
- (4) Mount this instrument in the panel considering the following conditions:
 - Provide adequate ventilation space so that heat does not build up.
 - Do not mount this instrument directly above the equipment that generates large amount of heat (heaters, transformers, semi-conductor functional devices, large-wattage resistors).
 - If the ambient temperature rises above 50 °C, cool this instrument with a forced air fan, cooler, etc. Cooled air should not blow directly on this instrument.
 - In order to improve safety and the immunity to withstand noise, mount this instrument as far away as possible from high voltage equipment, power lines, and rotating machinery.
 - High voltage equipment: Do not mount within the same panel.
 - Power lines: Separate at least 200 mm.
 - Rotating machinery: Separate as far as possible.
 - Mount this instrument in the horizontal direction for panel. If you did installation except a horizontal direction, this causes malfunction.
- (5) In case this instrument is connected to a supply by means of a permanent connection, a switch or circuit-breaker shall be included in the installation. This shall be in close proximity to the equipment and within easy reach of the operator. It shall be marked as the disconnecting device for the equipment.

2.2 Dimensions

■ HA430

(Unit: mm)

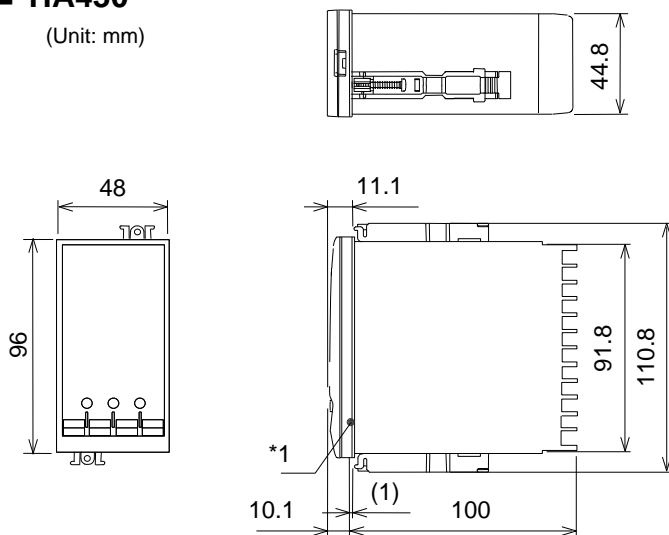

Individual mounting

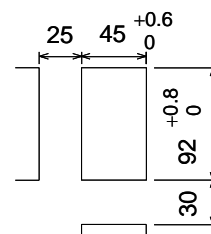

Close mounting*2, *3

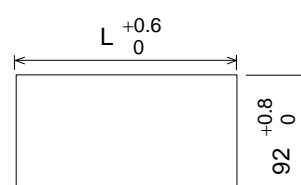

$L = 48 \times n - 3$ n: Number of units (2 to 6)

■ HA930

(Unit: mm)

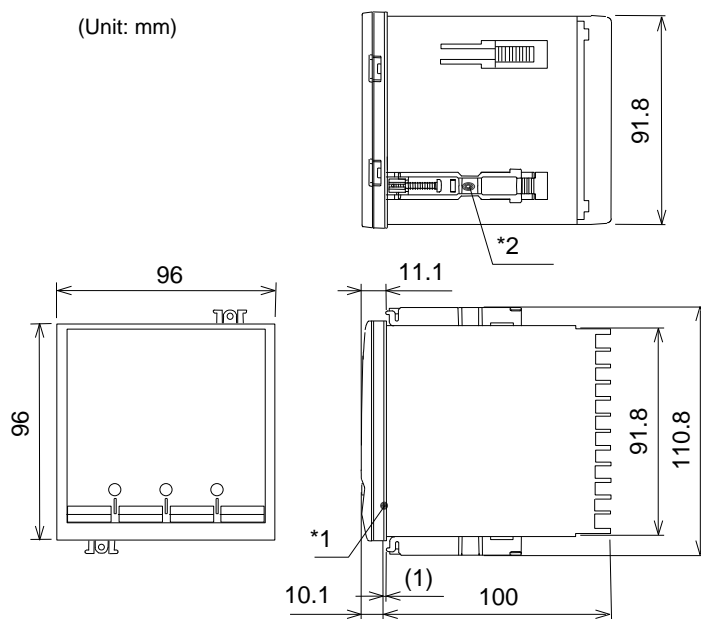

Individual mounting

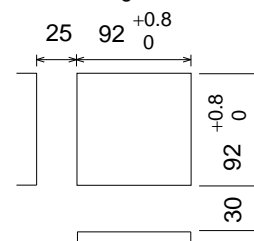

Close mounting*2, *3

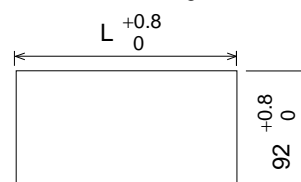

$L = 96 \times n - 4$ n: Number of units (2 to 6)

*1 Rubber gasket

*2 If the HA430s or HA930s have waterproof/dustproof, protection will be compromised and not meet IP65 by close mounting.

*3 When controllers are closely mounted, ambient temperature must not exceed 50 °C (122°F).

For mounting of the HA430 or HA930, panel thickness must be between 1 to 10 mm. When mounting multiple HA430s or HA930s close together, the panel strength should be checked to ensure proper support.

2.3 Procedures of Mounting and Removing

■ Mounting procedures

1. Prepare the panel cutout as specified in **2.2 Dimensions**.
(Panel thickness: 1 to 10 mm)
 2. Insert the instrument through the panel cutout.
 3. Insert the mounting bracket into the mounting groove of the instrument.
Do not push the mounting bracket forward. (Fig. 1)
 4. Secure the bracket to the instrument by tightening the screw.
Take care to refrain from moving the bracket forward.
 5. Only turn about one full revolution after the screw touches the panel. (Fig. 2)
-  If the screw has been rotated too tight, the screw may turn idle.
In such a case, loosen the screw once and tighten it again until the instrument is firmly fixed.
6. The other mounting bracket should be installed in the same way as described in **3.** to **5.**

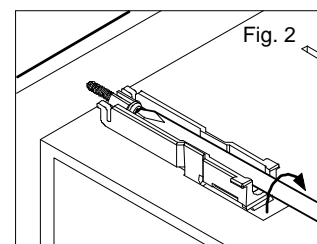
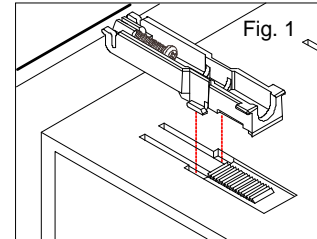



 When the instrument is mounted, always secure with two mounting brackets so that upper and lower mounting brackets are positioned diagonally.

 The waterproof/dustproof (supplied as standard) on the front of the instrument conforms to IP65 when mounted on the panel. Checked and confirmed its compliance through the internal test at RKC. For effective waterproof/dustproof, the gasket must be securely placed between the instrument and the panel without any gap. If the gasket is damaged, please contact RKC sales office or the agent.

■ Removal procedures

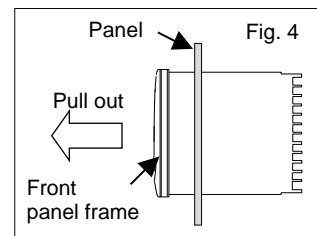
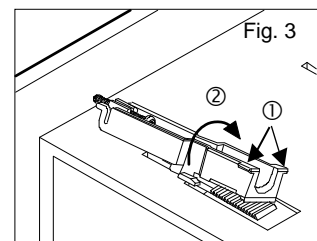
1. Turn the power OFF.
2. Remove the wiring.
3. Loosen the screw of the mounting bracket.
4. Hold the mounting bracket by the edge (①) and tilt it (②) to remove from the case. (Fig. 3)
5. The other mounting bracket should be removed in the same way as described in **3.** and **4.**
6. Pull out the instrument from the mounting cutout while holding the front panel frame of this instrument. (Fig. 4)



 When pulling out only the internal assembly from the instrument case after being wired, refer to **12. REMOVING THE INTERNAL ASSEMBLY (P. 126)**.

3. WIRING

This chapter describes wiring cautions, wiring layout and wiring of terminals.

WARNING

To prevent electric shock or instrument failure, do not turn on the power until all wiring is completed. Make sure that the wiring is correct before applying power to the instrument.

3.1 Wiring Cautions

- For thermocouple input, use the appropriate compensation wire.
- For RTD input, use low resistance lead wire with no difference in resistance between the three lead wires.
- Signal connected to Voltage input and Current input shall be low voltage defined as “SELV” circuit per IEC 60950-1.
- To avoid noise induction, keep input signal wire away from instrument power line, load lines and power lines of other electric equipment.
- Use a special shielded cable for connection with the pressure sensor.

When using our CZ-100P or CZ-200P:

The rated output value (mV/V) of pressure sensor is when the cable is at a length of 5 m. If the cable is extended, correct the rated output value using the following equation. Set the correction value thus calculated to “Gain setting (GAIN)” on page 67.

Correction equation: $e1 = e2 (1 + K \cdot L)$ \longrightarrow $e2 = \frac{e1}{1 + K \cdot L}$

e1: Rated output in standard-cable length 5 m (mV/V is described on the nameplate of the sensor)
 e2: Rated output after extension
 K: Correction factor* $1.96 \times 10^{-4}/m$ [Non-explosionproof specification type],
 $1.40 \times 10^{-4}/m$ [Explosionproof specification type]
 * When using $0.5 \text{ mm}^2 \times 4$ -core shielded cable (standard-cable) or equal.
 L: Extended cable length (m)

- If there is electrical noise in the vicinity of the instrument that could affect operation, use a noise filter.
 - Shorten the distance between the twisted power supply wire pitches to achieve the most effective noise reduction.
 - Always install the noise filter on a grounded panel. Minimize the wiring distance between the noise filter output and the instrument power supply terminals to achieve the most effective noise reduction.
 - Do not connect fuses or switches to the noise filter output wiring as this will reduce the effectiveness of the noise filter.
- Allow approximately 5 seconds for contact output when the instrument is turned on. Use a delay relay when the output line is used for an external interlock circuit.
- Power supply wiring must be twisted and have a low voltage drop.
- This instrument is not provided with an overcurrent protection device. For safety install an overcurrent protection device (such as a fuse) with adequate breaking capacity close to the instrument.
 - Fuse type: Time-lag fuse (Approved fuse according IEC 60127-2 and/or UL 248-14)
 - Fuse rating: Rated current: 1.0 A
- For an instrument with 24 V power supply input, supply power from a “SELV” circuit defined as IEC 60950-1.
- A suitable power supply should be considered in end-use equipment. The power supply must be in compliance with a limited-energy circuits (maximum available current of 8 A).
- Use the solderless terminal appropriate to the screw size.

Screw size: M3 × 6 (With 5.8 × 8 square washer)

Recommended tightening torque:
0.4 N·m (4 kgf·cm)

Specified solderless terminals:
With isolation

Applicable wire: Solid/twisted wire of 0.25 to 1.65 mm²

- Make sure that during field wiring parts of conductors cannot come into contact with adjacent conductive parts.

Recommended dimension:

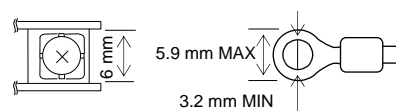

3.2 Terminal Layout

The terminal layout is as follows.

■ HA430

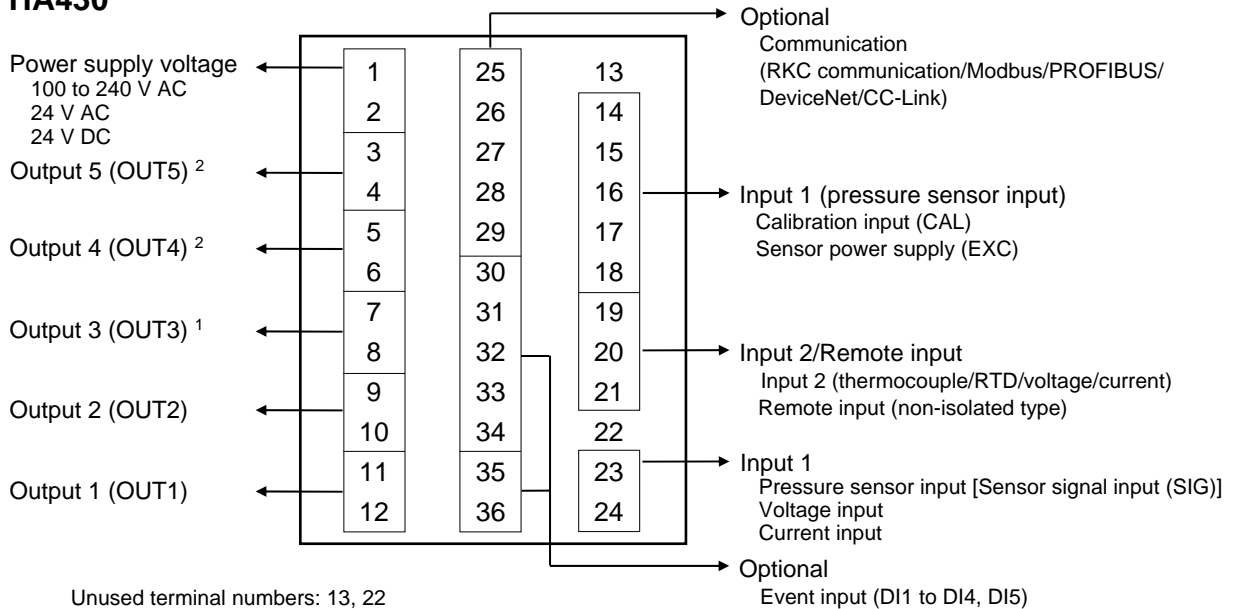

¹ OUT3 can be used for Sensor power supply (optional) [Specify when ordering]

² If OUT3 is selected for Sensor power supply, OUT4 and OUT5 cannot be used.

■ HA930

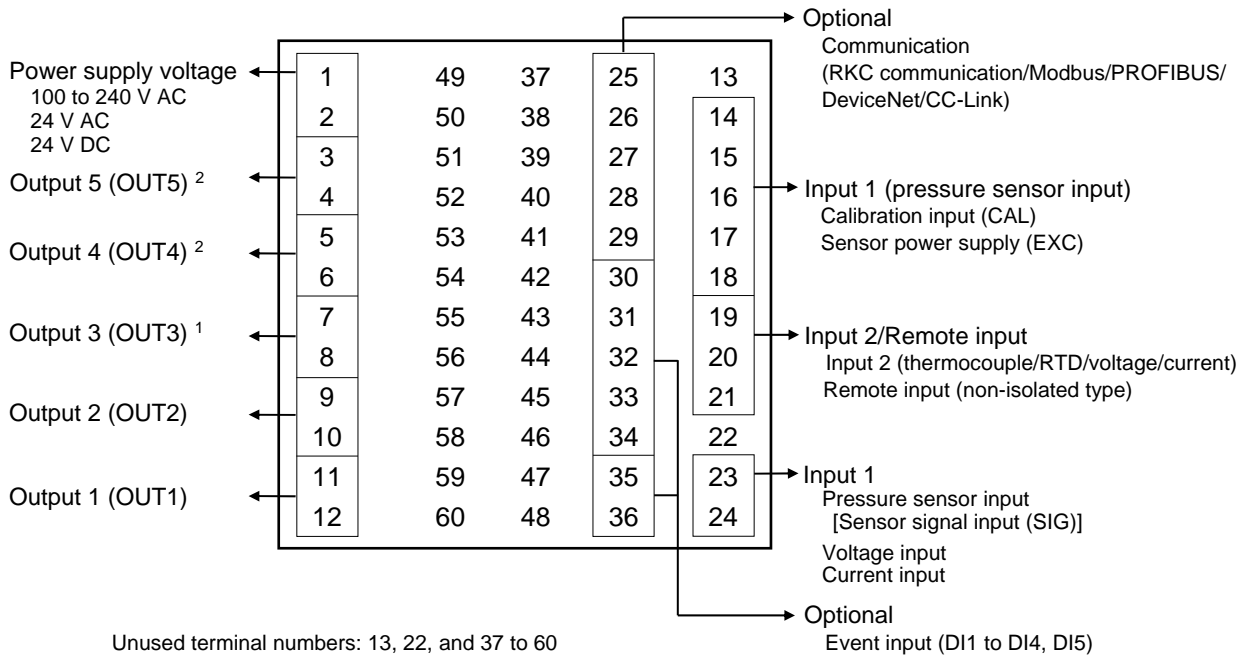

¹ OUT3 can be used for Sensor power supply (optional) [Specify when ordering]

² If OUT3 is selected for Sensor power supply, OUT4 and OUT5 cannot be used.

3.3 Wiring of Each Terminal

Prior to conducting wiring, always check the polarity of each terminal.



The terminal nameplate of this instrument and its descriptions are shown in the following.

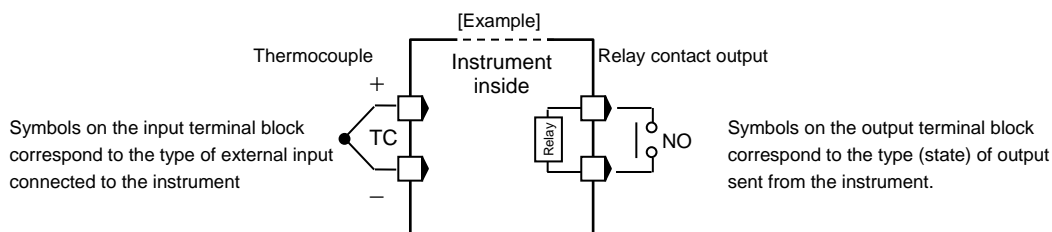

■ Power supply

- Connect the power to terminal numbers 1 and 2.

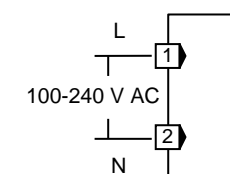

100 to 240 V AC power supply type

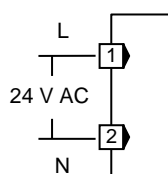

24 V AC power supply type

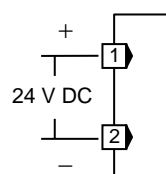

24 V DC power supply type

- The power supply types must be specified when ordering. Power supply voltage for the controller must be within the range shown below for the controller to satisfy the control accuracy in the specifications.

Power supply type	Power consumption
90 to 264 V AC [Including power supply voltage variation] (Rating 100 to 240 V AC), 50/60 Hz	HA430: 16.5 VA max. (at 100 V AC), 22.5 VA max. (at 240 V AC) HA930: 17.5 VA max. (at 100 V AC), 24.0 VA max. (at 240 V AC)
21.6 to 26.4 V AC [Including power supply voltage variation] (Rating 24 V AC), 50/60 Hz	HA430: 15.0 VA max. (at 24 V AC) HA930: 16.0 VA max. (at 24 V AC)
21.6 to 26.4 V DC [Including power supply voltage variation] (Rating 24 V DC)	HA430: 430 mA max. (at 24 V DC) HA930: 470 mA max. (at 24 V DC)

- If there is electrical noise in the vicinity of the instrument that could affect operation, use a noise filter.
- Power supply wiring must be twisted and have a low voltage drop.
- This instrument is not provided with an overcurrent protection device. For safety install an overcurrent protection device (such as a fuse) with adequate breaking capacity close to the instrument.
 - Fuse type: Time-lag fuse (Approved fuse according IEC 60127-2 and/or UL 248-14)
 - Fuse rating: Rated current: 1.0 A
- For an instrument with 24 V power supply input, supply power from a “SELV” circuit defined as IEC 60950-1.
- A suitable power supply should be considered in end-use equipment. The power supply must be in compliance with a limited-energy circuits (maximum available current of 8 A).

■ Output 1 to 3 (OUT1 to OUT3)

- Terminal 11 and 12 are for output 1 (OUT1); Terminal 9 and 10 are for output 2 (OUT2); and Terminal 7 and 8 are for output 3 (OUT3).
- Connect an appropriate load according to the output type.

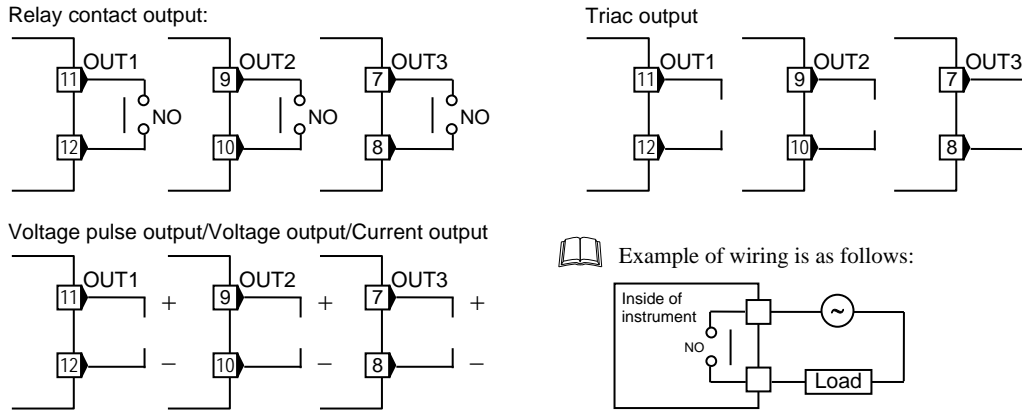

- Number of outputs and output types must be specified when ordering. Control output, Event output, or Transmission output can be allocated to output 1 to 3. The specifications of each output are as follows.

Output type	Specifications
Relay contact output	250 V AC, 3A (Resistive load), 1a contact Electrical life 300,000 times or more (Rated load)
Voltage pulse output	0/12 V DC (Load resistance: 600 Ω or more)
Triac output	0.4 A (Allowable load current)
Voltage output	0 to 5 V DC, 1 to 5 V DC, 0 to 10 V DC (Load resistance: 1 kΩ or more) Output resolution: 11 bits or more
Current output	0 to 20 mA DC, 4 to 20 mA DC (Load resistance: 600 Ω or less) Output resolution: 11 bits or more

- OUT3 is isolated from both OUT1 and OUT2.
- OUT1 and OUT2 are not isolated from each other except for relay or triac output. When relay or triac output is used, there is isolation between outputs.
- There is isolation between input and output.
- There is isolation between output and power supply terminals.

If OUT3 is used for the Sensor power supply, refer to **Sensor power supply (optional)** on page 20.

■ Output 4 to 5 (OUT4 to OUT5)

- Terminal 5 and 6 are for output 4 (OUT4); and Terminal 3 and 4 are for output 5 (OUT5).
- Output type is only relay contact output.

Relay contact output 250 V AC, 1A (Resistive load), 1a contact Electrical life 300,000 times or more (Rated load)

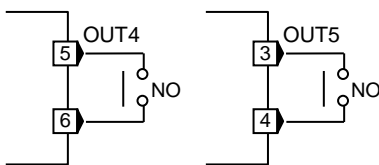

- OUT4 and OUT5 can be used for Event output.
- If OUT3 is selected for the Sensor power supply, OUT4 and OUT5 cannot be used.

■ Input 1 (pressure sensor input)

- Input 1 can be used for the pressure sensor input. (Specify when ordering)
- The strain gauge type of pressure sensor is only connectable.
- The pressure sensor types must be specified when ordering. The relevant pressure sensors are as follows.
 - Our CZ-100P or CZ-200P
 - Resin pressure sensor (Strain gauge type)* other than RKC product
 - * Rated output: 0.500 to 4.000 mV/V Maximum supply voltage: More than 8 V DC
- Directly connect the pressure sensor (without amplifier) connection cable to terminal numbers 14 to 18, 23 and 24. As for the sensor cable connection, refer to the instruction manual for Pressure sensor used.

Wiring example: Connection to our CZ-100P or CZ200P

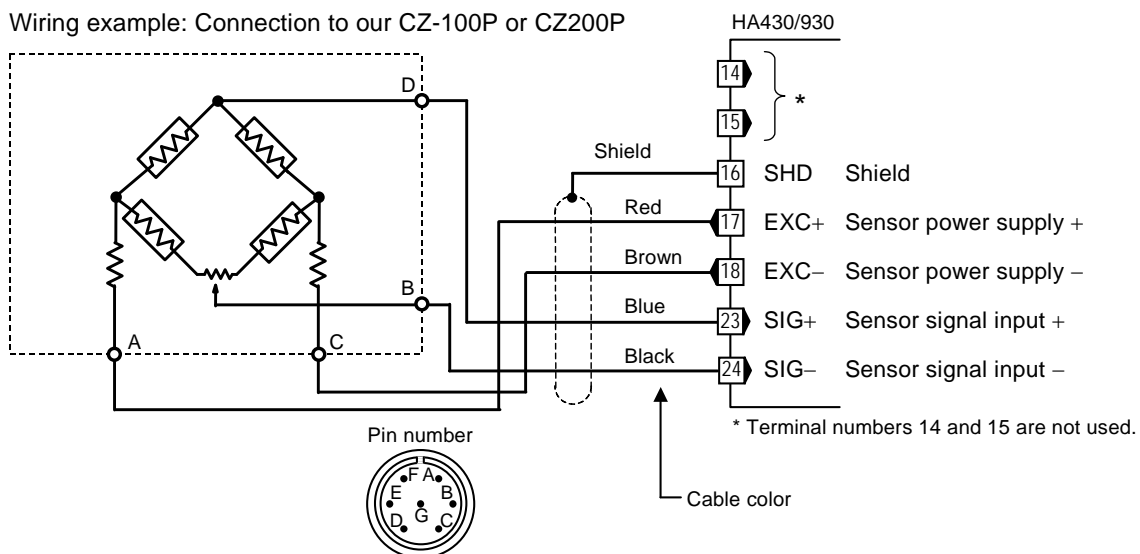

■ **Input 1 (voltage and current inputs)**

- Input 1 can be used for the voltage or current input. (Specify when ordering)

Voltage (low)	0 to 100 mV DC, 0 to 10 mV DC, 0 to 1 V DC, ±10 mV DC, ±100 mV DC	[Factory set value: 0 to 1 V DC]
Voltage (high)	0 to 5 V DC, 1 to 5 V DC, DC 0 to 10 V DC, ±1 V DC, ±5 V DC, ±10 V DC	[Factory set value: 1 to 5 V DC]
Current	0 to 20 mA DC, 4 to 20 mA DC	[Factory set value: 4 to 20 mA DC]

- The pressure sensor types must be specified when ordering. The relevant pressure sensors are as follows.
Resin pressure sensor (Strain gauge type) other than RKC product
- The sensor power supply can be allocated to the input terminal numbers 23 and 24.

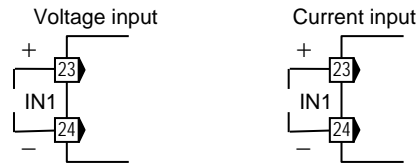

Wiring example 1:

When the resin pressure sensor of 0 to 5 V or 0 to 10 V DC (with amplifier) output type is connected

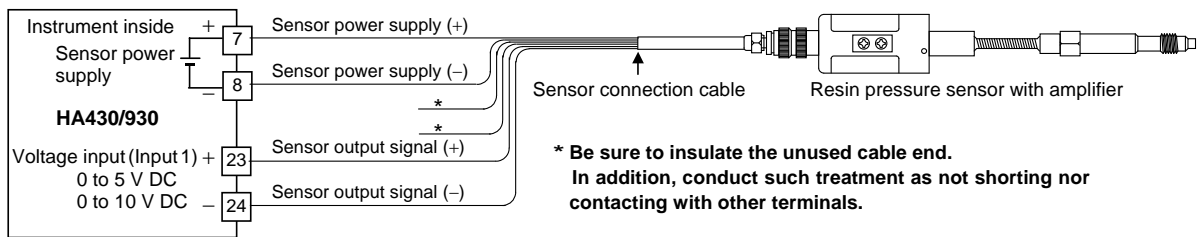

Wiring example 2:

When the resin pressure sensor of 4 to 20 mA DC (with amplifier) output type is connected

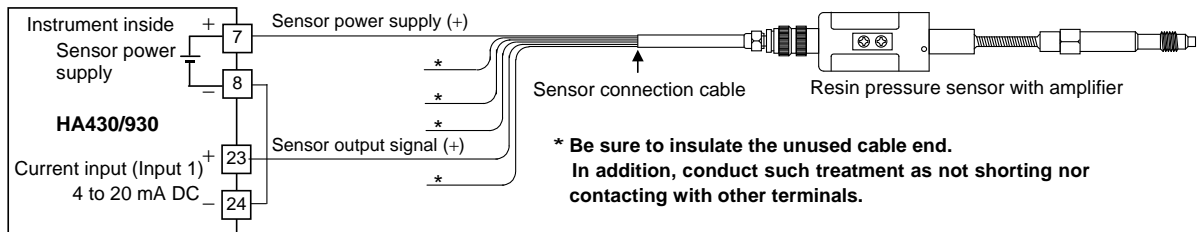

Wiring example 3: Connection to 2-wire pressure transmitter (4 to 20 mA DC type)

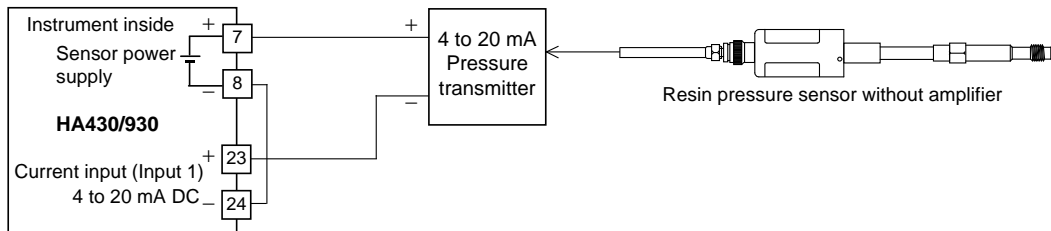

■ Input 2 (thermocouple, RTD, voltage, and current inputs)

- Input 2 can be used for the thermocouple, RTD, voltage, or current input.
- For the Input 2, terminals 19 to 21 are allocated to the measured input.

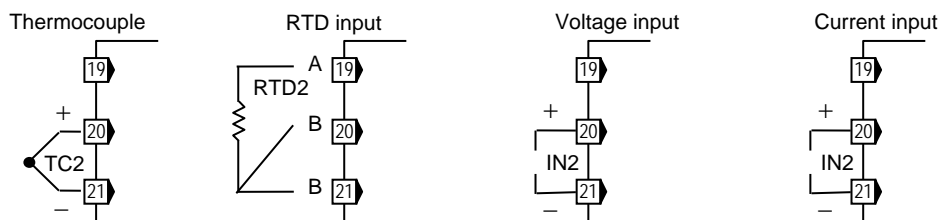

- The input types needs to be specified when ordering. The input types are as follows.

Thermocouple: K, J, T, S, R, E, B, PLII, N, W5Re/W26Re	Voltage (low): 0 to 100 mV DC, 0 to 10 mV DC, 0 to 1 V DC, ±10 mV DC, ±100 mV DC
	Voltage (high): 0 to 5 V DC, 1 to 5 V DC, 0 to 10 V DC, ±1 V DC, ±5 V DC, ±10 V DC
RTD: Pt100, JPt100	Current: 0 to 20 mA DC, 4 to 20 mA DC

- For thermocouple input, use an appropriate compensation wire. For RTD input, use the same low resistance lead wires for all connections.
- Signal connected to Voltage input and Current input shall be low voltage defined as “SELV” circuit per IEC 60950-1.
- If Input 2 is for voltage input or current input and the sensor power supply is specified to OUT3, terminal numbers 20 and 21 can be used as sensor signal input terminals for the pressure sensor (with amplifier).

☞ Refer to ■ Sensor power supply (P. 20)

■ Remote input (optional)

- With non-isolated remote input, terminals 19 to 20 are allocated to Remote input.

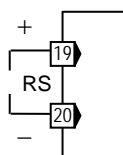

Any one of the following input types can be selected.

Voltage (low):	0 to 100 mV DC, 0 to 10 mV DC, 0 to 1 V DC, ±10 mV DC, ±100 mV DC
Voltage (high):	0 to 5 V DC, 1 to 5 V DC, 0 to 10 V DC, ±1 V DC, ±5 V DC, ±10 V DC
Current:	0 to 20 mA DC, 4 to 20 mA DC

- Measured input is not isolated from Remote input (non-isolated type).

■ Event input (optional)

With Event input, terminals 30 to 36 are allocated to Event input. Event input must be specified when ordering.

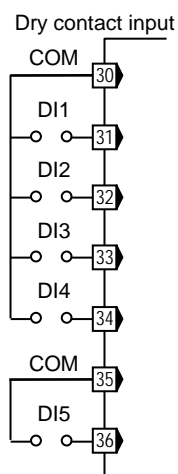

Contact input from external devices or equipment should be dry contact input. If it is not dry contact input, the input should have meet the specifications below.

Contact specifications: At OFF (contact open): 500 kΩ or more
At ON (contact closed) 10 Ω or less

The following functions can be assigned to event inputs.

Memory area selection, RUN/STOP transfer, Remote/Local transfer, Auto/Manual transfer, Hold reset, Interlock release, Manual output up/down (Motor RPM up/down), Manual output 0 % reset (Motor RPM reset)

☞ To assign functions to event inputs, refer to **8. ENGINEERING MODE (P. 50)**

When CC-Link function is specified for Communication function, terminal Nos.30 to 36 are not available for Event input.

■ **Sensor power supply (optional)**

- The Sensor power supply is used to supply power to pressure sensor with amplifier or 2-wire pressure transmitter. (Specify when ordering)
- The Sensor power supply can be allocated to the output terminal numbers 7 and 8.

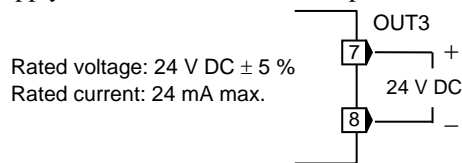

Wiring example 1:

When the resin pressure sensor of 0 to 5 V or 0 to 10 V DC (with amplifier) output type is connected

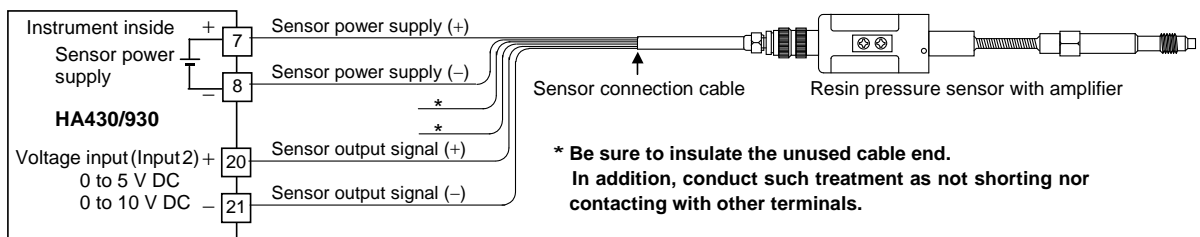

Wiring example 2:

When the resin pressure sensor of 4 to 20 mA DC (with amplifier) output type is connected

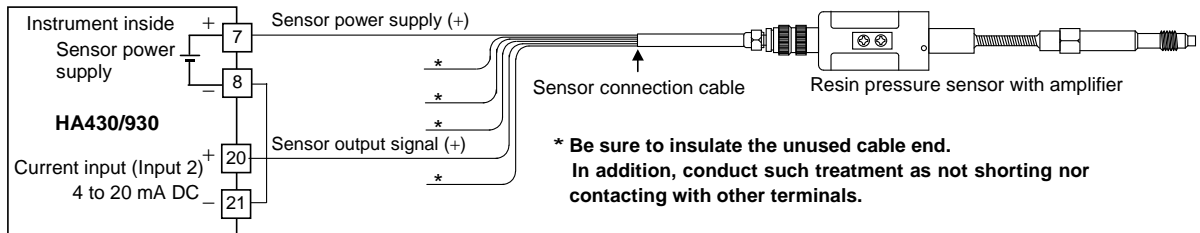

Wiring example 3: Connection to 2-wire pressure transmitter (4 to 20 mA DC type)

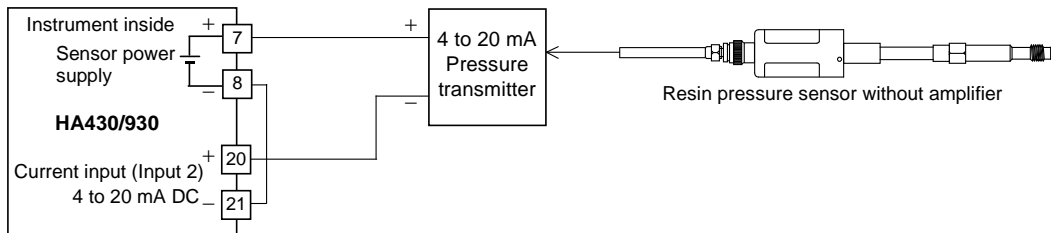

- OUT4 and OUT5 cannot be used if the Sensor power supply is specified. The number of output points which can correspond to control output, event output and transmission output becomes 2 maximum (OUT1 and OUT2).

■ **Communication (optional)**

- With Communication function, terminals 25 to 29 are allocated to Communication.
- Conduct wiring to the relevant terminals meeting the specified communication interface. For details of wiring, refer to **Communication Instruction Manual (IMR01N13-E□)**. *

* Refer to **Communication Instruction Manual (IMR01N14-E□)** for PROFIBUS, **Communication Instruction Manual (IMR01N15-E□)** for DeviceNet, and **Communication Instruction Manual (IMR01N21-E□)** for CC-Link.

Continued on the next page.

Continued from the previous page.

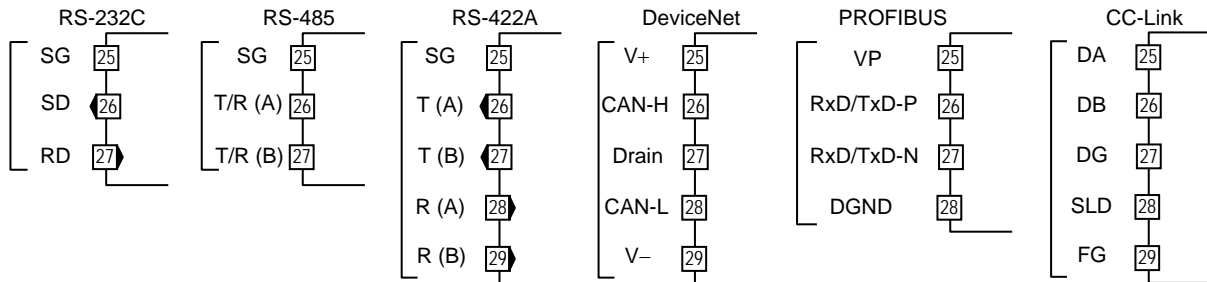

Example 1: Connection to the RS-232C port of the host computer (master)

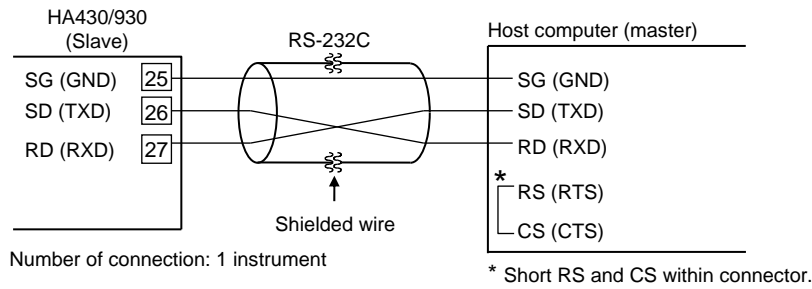

Example 2: Connection to the RS-485 port of the host computer (master)

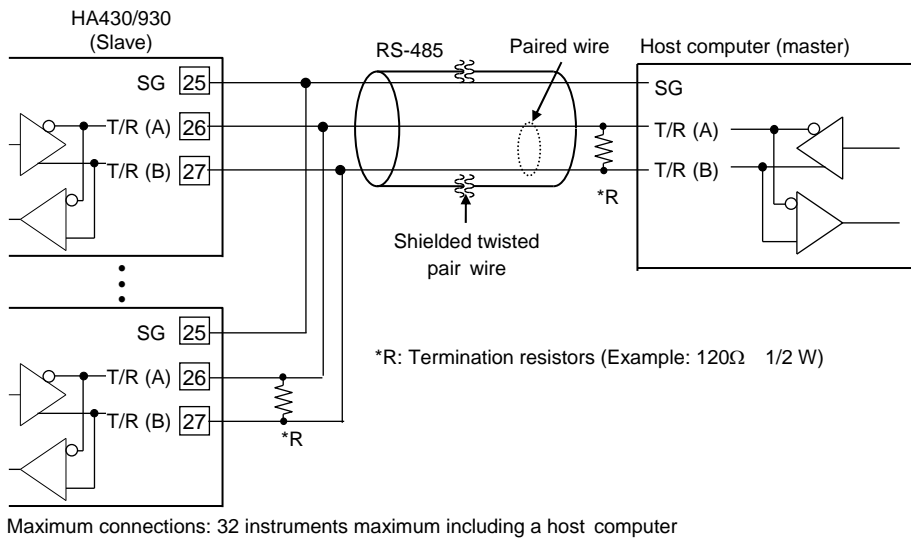

Example 3: Connection to the RS-422A port of the host computer (master)

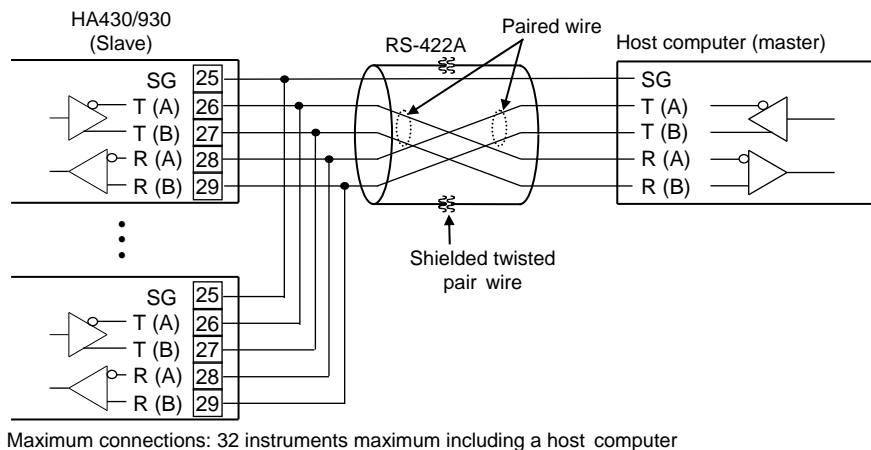

4. SETTING

This chapter describes procedures to set operating conditions of a customer and parameter of various setting modes.

4.1 Setting Procedure to Operation

Conduct necessary setting before operation according to the procedure described below.

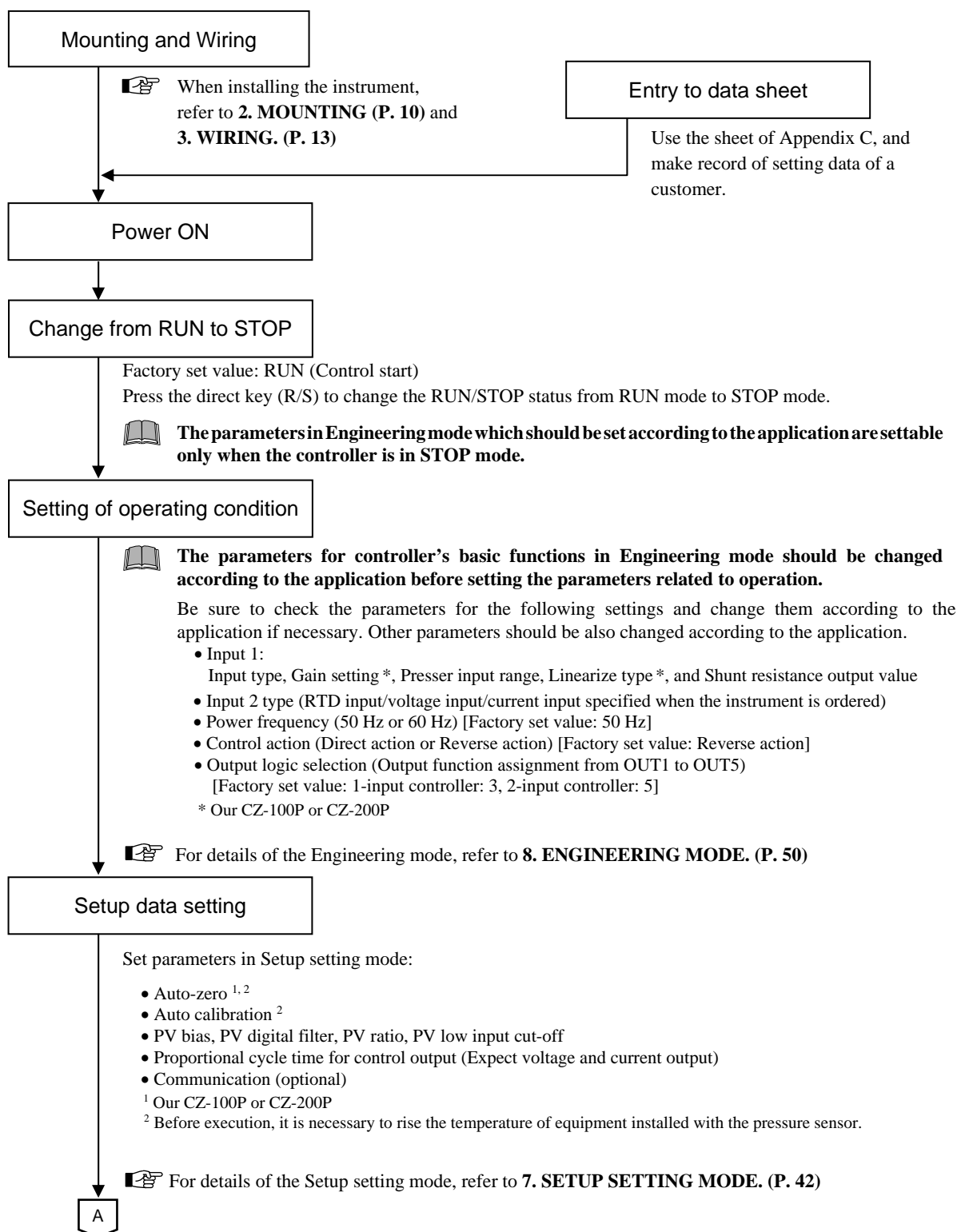

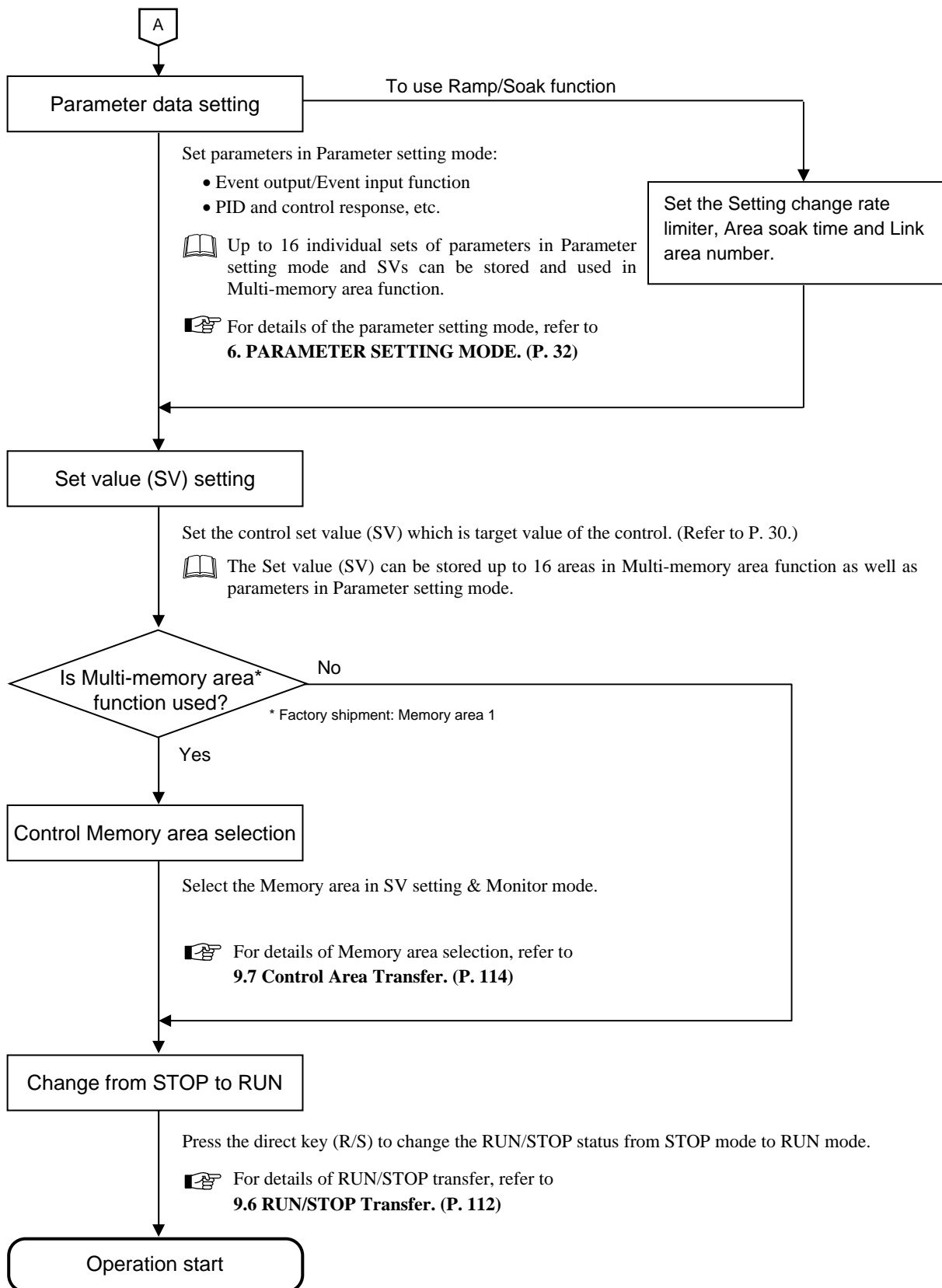

4.2 Operation Menu

The controller has five different setting modes. All settable parameters belong to one of them. The following chart shows how to access different setting mode.

For the details of key operation, refer to **4.3 Key Operation. (P. 26)**

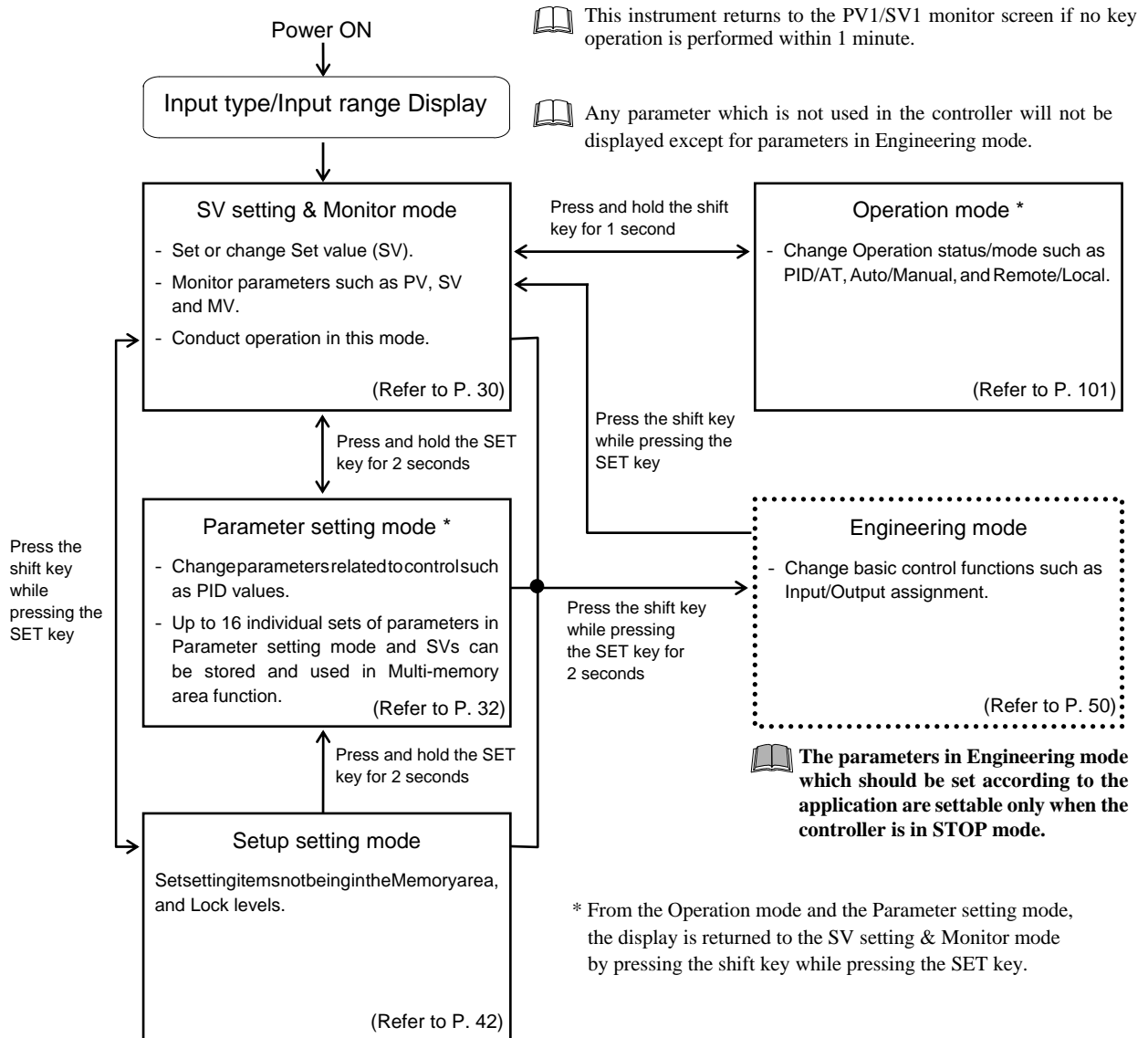

■ Input type and input range display

This instrument immediately confirms inputs type symbol and input range following power ON.

Example: When sensor type of Input 1 is pressure input, and sensor type of Input 2 is K thermocouple (2-input controller)

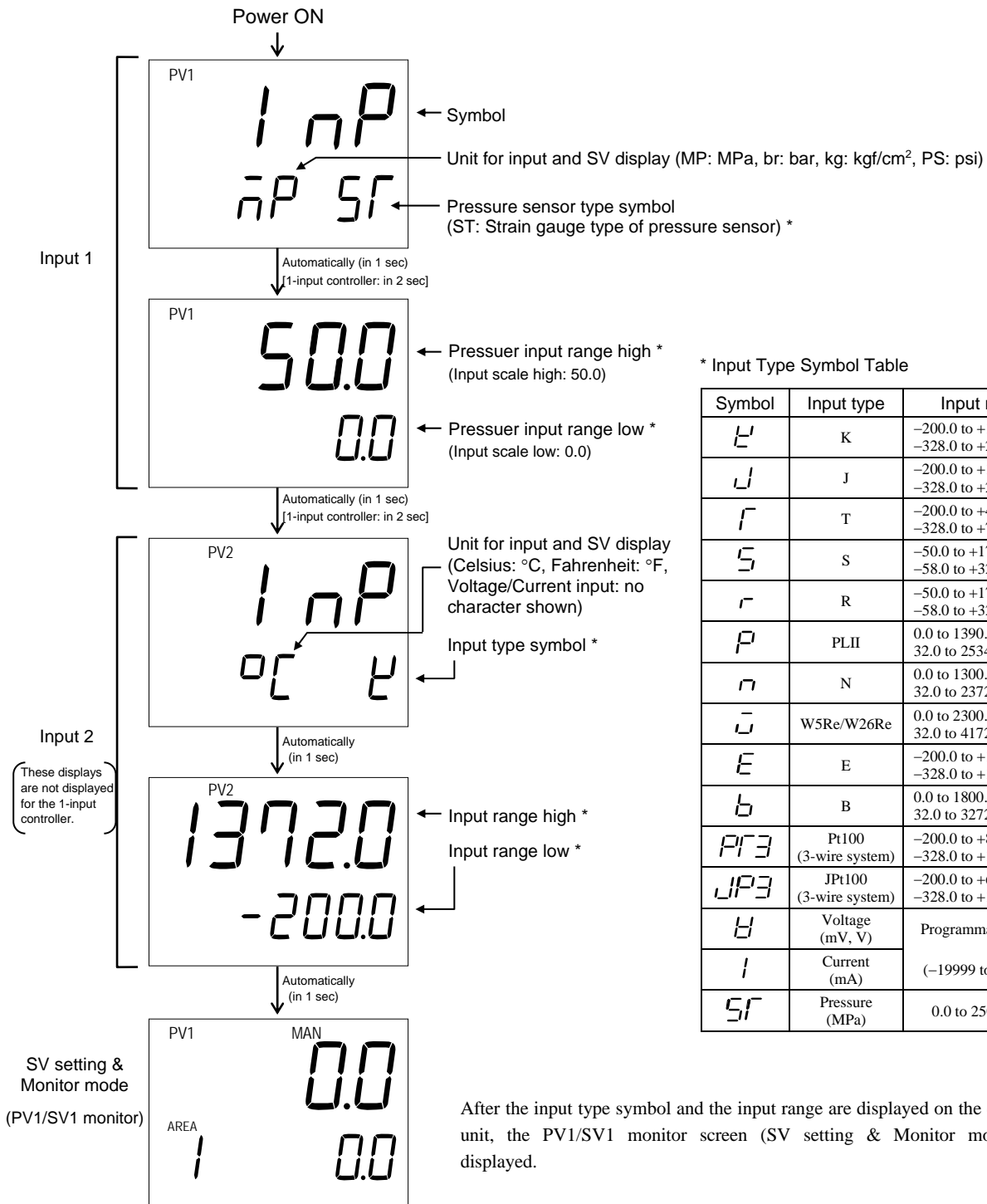

4.3 Key Operation

Basic key operations common to each mode (set item change, set value change and registration) and Data lock function are described in the following.

■ Scrolling through parameters

- Press to scroll through parameters in the same mode/area.
- To go back to the first parameter, keep pressing SET keys until it is displayed again.

Example: When the SV setting & Monitor mode is selected (2-input controller)

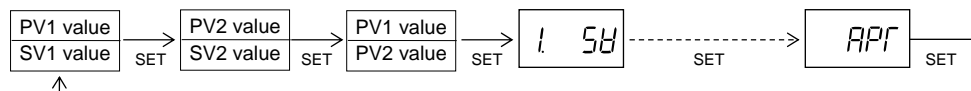

■ Changing Set value (SV)

- The high-lighted digit indicates which digit can be set. Press Shift key to go to a different digit. Every time the shift key is pressed, the high-lighted digit moves as follows.

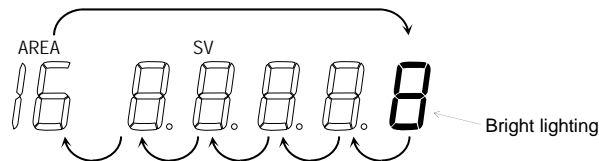

The following is also available when changing the set value.

- Increase SV1 from 199.9 MPa to 200.0 MPa:

1. Press the shift key to light brightly the tenths place (first digit from the right).
2. Press the UP key to change to 0.
The display changes to 200.0.

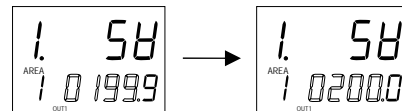

- Decrease SV1 from 200.0 MPa to 190.0 MPa:

1. Press the shift key to light brightly the tens place.
2. Press the DOWN key to change to 9.
The display changes to 190.0.

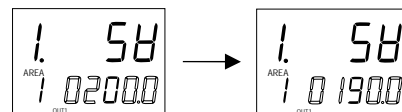

- Decrease SV2 from 200.0 °C to -100.0 °C:

1. Press the shift key to light brightly the hundreds place.
2. Press the DOWN key (three times) to change to -1.
The display changes to -100.0.

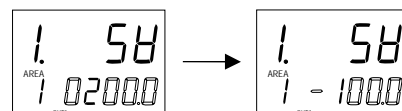

- **To store a new value for the parameter, always press the SET key.** The display changes to the next parameter and the new value will be stored.

A new value will not be stored without pressing SET key after the new value is displayed on the display.

After a new value has been displayed by using the UP and DOWN keys, the SET key must be pressed within 1 minute, or the new value is not stored and the display will return to the PV1/SV1 monitor screen.

■ Data lock function

- The Data lock function limits access of unauthorized personnel to the parameters and prevents parameter change by mistake.
- There are 8 set data lock levels. The set data lock level can be set in Setup setting mode.

Character display	Parameters which can be changed	Set value
	All parameters [Factory set value]	00000
	SV, EV1 to EV4, Memory area selection, Parameters in F10 to F91	00001
	All parameters except for EV1 to EV4	00010
	SV	00011
	All parameters except for SV	00100
	EV1 to EV4	00101
	All parameters except for SV and EV1 to EV4	00110
	No parameter (All Locked)	00111

- Data lock level can be changed in both RUN and STOP mode.
- Parameters protected by Data lock function are still displayed for monitoring.

■ How to restrict operation of the direct keys

Three Direct function keys on the front panel are provided for one-key operation to switch Auto/Manual, Remote/Local, and RUN/STOP. Use/Unuse of Direct keys is settable in Engineering mode. (Refer to P. 65.)

4.4 Changing Parameter Settings

Procedures to change parameter settings are shown below.

■ Change Settings

Example: Change the Set value 1 (SV1) of Input 1 from 0.0 MPa to 200.0 MPa

1. Go to the mode in which the parameter is displayed

If the current mode is not SV setting & Monitor mode, press the shift key while pressing the SET key to return to the SV setting & Monitor mode.

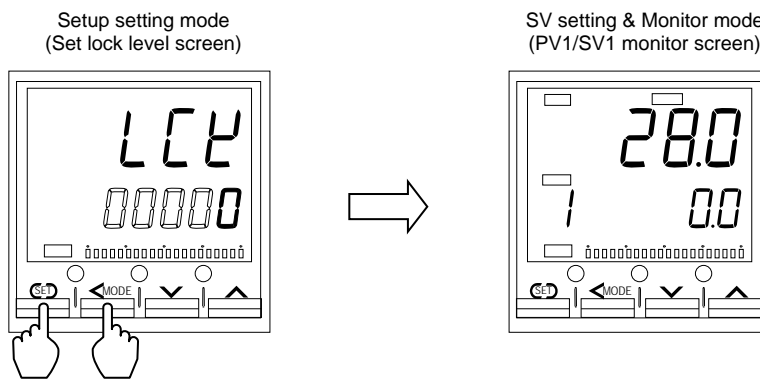

 For the mode transfer, refer to **4.2 Operation Menu. (P. 24)**

2. Select the parameter

Press the SET key until "1. SV" (Input 1_SV1 setting screen) is displayed. To go to the next parameter, press SET key. To go back to the first parameter, keep pressing SET keys until it is displayed again.

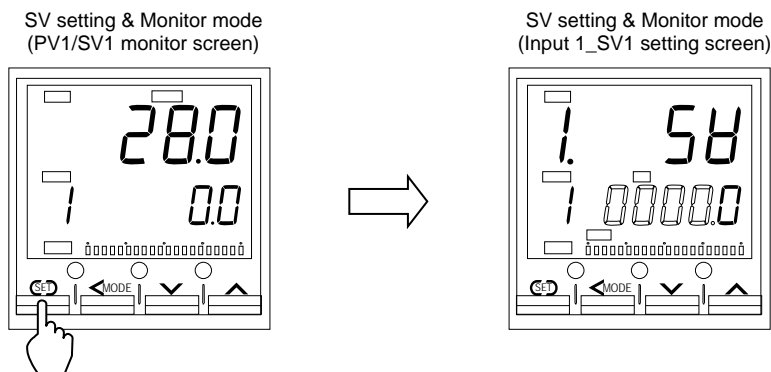

Continued on the next page.

3. Shift the high-lighted digit

The high-lighted digit indicates which digit can be set. Press the shift key to high-light the hundreds digit.

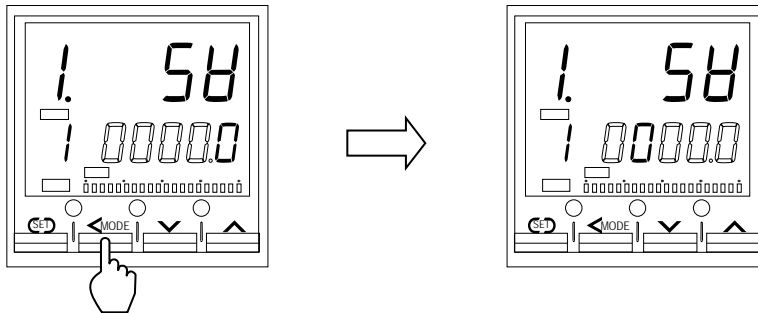

4. Change the set value

Press the UP key to change the number to 2.

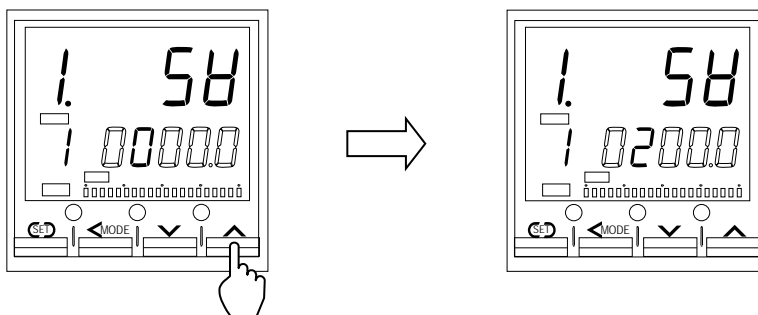

5. Store the set value

Press the SET key to store the new set value. The display goes to the next parameter.

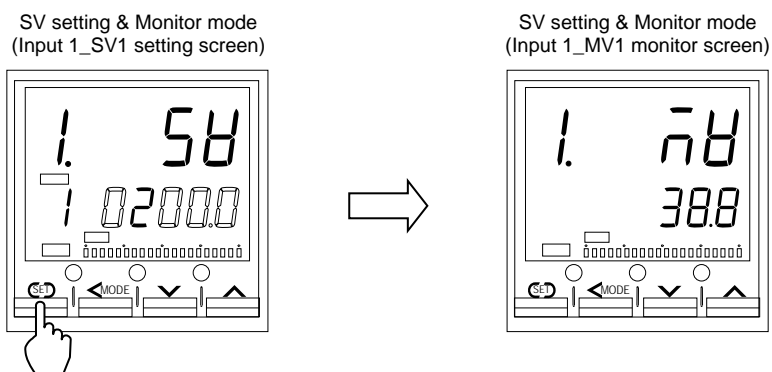

5. SV SETTING & MONITOR MODE

5.1 Display Sequence

In SV setting & Monitor mode, the following operations are possible.

Change the Set value (SV)

Change Memory Area

Monitor the Measured value (PV) and the Manipulated value (MV), etc.

When the power is turned on, the controller goes to this mode after self-diagnostics. Use this mode during normal operation. To return to this mode from the Operation mode or the Parameter setting mode, press the shift key while pressing the SET key.

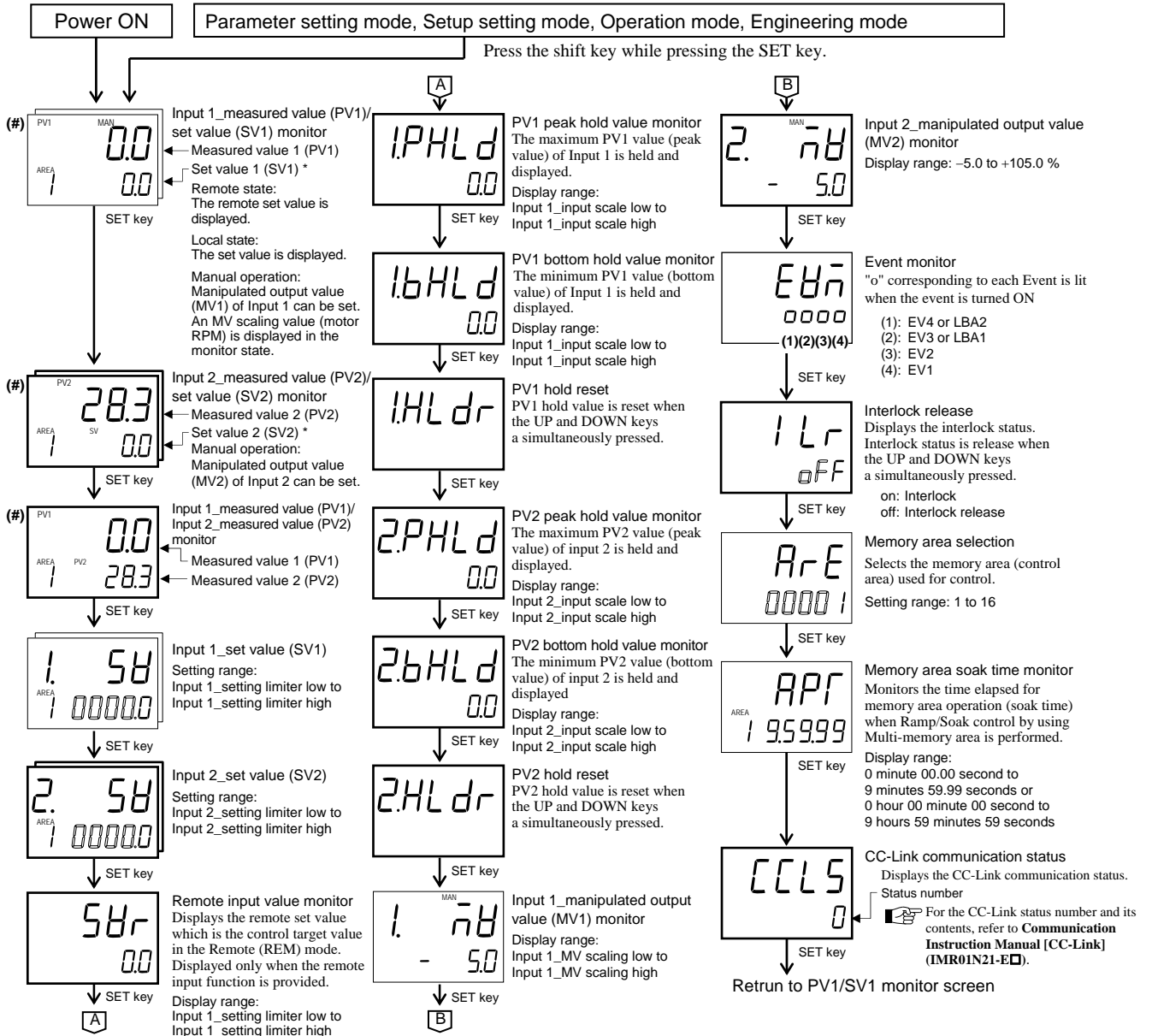

* With the Setting change rate limiter when the set value is changed, the displayed set value changes according to the ramp-up/down rate.

: Parameters related to multi-memory area function : Parameters displayed when function is specified.

Parameters which are not related to existing functions on the controller are not displayed.

This instrument returns to the PV1/SV1 monitor screen if no key operation is performed within 1 minute. [Exempts, screen of (#) mark]

For the monitor screen, refer to **9.3 Monitoring Display in Operation. (P. 102)**

For the memory area selection, refer to **9.7 Control Area Transfer. (P. 114)**

5.2 Procedure for Set Value (SV) Setting

Up to 16 individual sets of SVs and parameters in Parameter setting mode can be stored and used in Multi-memory area function. Some examples of changing the Set value (SV) described in the following. The same setting procedure applies when parameters corresponding to the Multi-memory area function are also set.

● Change the Set value (SV)

Change SV1 of Input 1 from 0.0 MPa to 200.0 MPa:

1. Press the SET key several times at PV1/SV1 monitor screen until Input1_SV1 setting screen is displayed.

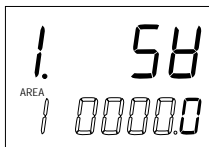

2. Press the shift key to high-light the hundreds digit. The high-lighted digit indicates which digit can be set.

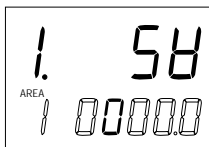

3. Press the UP key to change the number to 2.

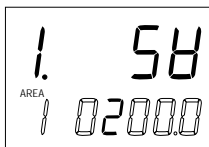

4. Press the SET key to store the new value. The display goes to the next parameter. (Example: Input 2_SV2 setting screen)

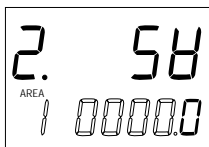

● Change the Set value (SV) of another Memory area which is not selected for ongoing control

While Memory area 1 is selected for ongoing control, change SV1 of Input 1 in Memory area 3 from 150.0 MPa to 100.0 MPa:

1. Go to Input 1_SV1 setting screen. Press the shift key until the Memory area display unit is high-lighted. The high-lighted digit indicates which digit can be set.

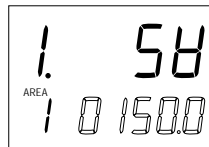

2. Press the UP key to change to 3. The SV display shows the Set value (SV1) of Input 1 of the Memory area 3, and the number in AREA (Area number) display flashes.

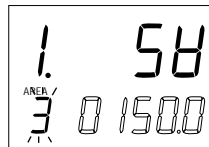

3. Press the shift key to high-light the tens digit. The Area number is flashing.

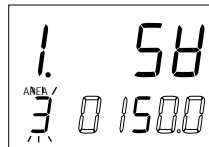

4. Press the DOWN key to change the number to 0 in the tens digit.

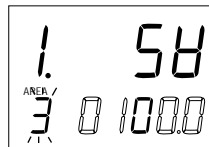

5. Press the SET key to store the new value. The display goes to the next parameter. (Example: Input 2_SV2 setting screen)

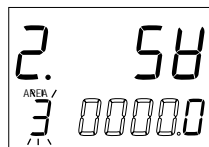

6. PARAMETER SETTING MODE

6.1 Display Sequence

In Parameter setting mode, the following operations are possible. Set parameters relating to control such as PID constants, Event set values, and the Setting change rate limiter. To go to Parameter setting mode, press and hold the SET key for 2 seconds at SV setting & Monitor mode or Setup setting mode. Up to 16 individual sets of SVs and parameters in Parameter setting mode can be stored and used in Multi-memory area function. Ramp/Soak control is possible by using Area soak time, Link area number and Setting change rate limiter (up/down) in Parameter setting mode.

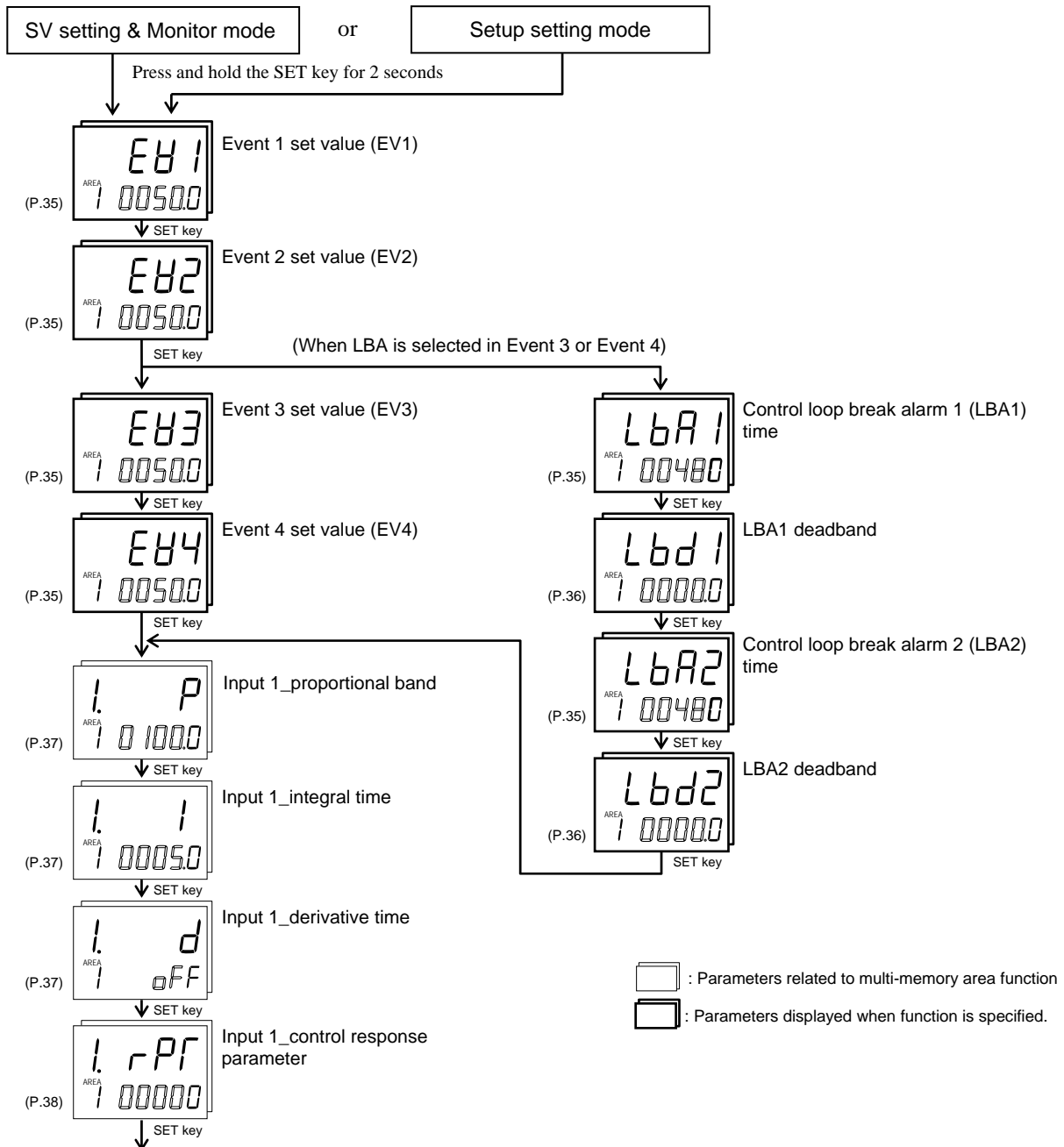

Continued on the next page *

*For 1-input controller: To Input 1_setting change rate limiter (up) screen
For 2-input controller: To Input 2_proportional band screen

From Input 1_control response parameter setting screen

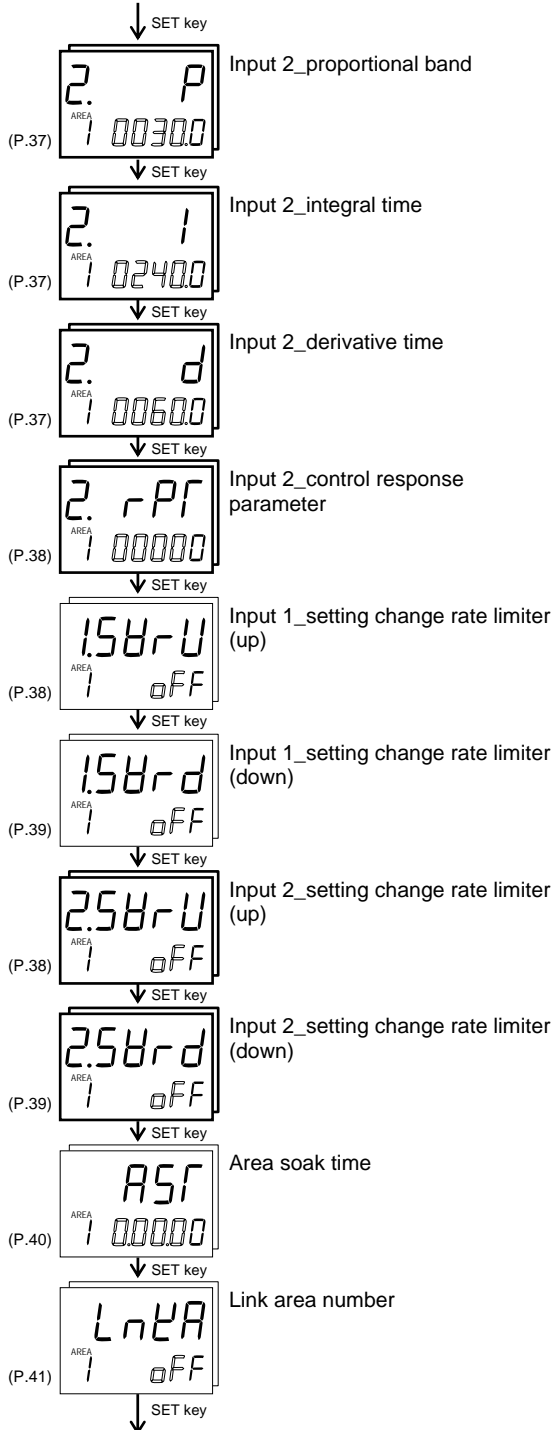

Multi-memory area function:

- Multi-memory area function can store up to 16 individual sets of SVs and parameters in Parameter setting mode. One of the Areas is used for control, and the currently selected area is "Control Area".

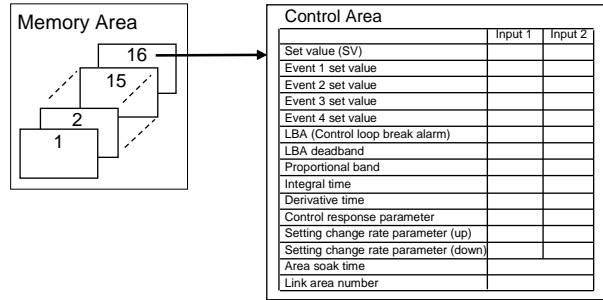

- Ramp/Soak control is possible by using Area soak time, Link area number and Setting change rate limiter (up/down) in Parameter setting mode.

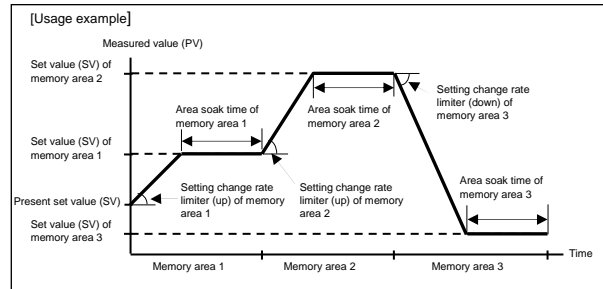

: Parameters related to multi-memory area function
 : Parameters displayed when function is specified.

Return to first parameter setting item of Parameter setting mode

- Parameters which are not related to existing functions on the controller are not displayed.
- To return the SV setting & Monitor mode, press and hold the SET key for 2 seconds, or press the shift key while pressing the SET key.
- This instrument returns to the PV1/SV1 monitor screen if no key operation is performed within 1 minute.

6.2 Parameter List

Parameter		Page
Event 1 set value	<i>EV1</i> (EV1)	P. 35
Event 2 set value	<i>EV2</i> (EV2)	P. 35
Event 3 set value	<i>EV3</i> (EV3)	P. 35
Event 4 set value	<i>EV4</i> (EV4)	P. 35
Control loop break alarm 1 (LBA1) time	<i>LbA1</i> (LbA1)	P. 35
LBA1 deadband	<i>Lbd1</i> (Lbd1)	P. 36
Control loop break alarm 2 (LBA2) time	<i>LbA2</i> (LbA2)	P. 35
LBA2 deadband	<i>Lbd2</i> (Lbd2)	P. 36
Input 1_proportional band	<i>1 P</i> (1. P)	P. 37
Input 1_integral time	<i>1 I</i> (1. I)	P. 37
Input 1_derivative time	<i>1 d</i> (1. d)	P. 37
Input 1_control response parameter	<i>1 rPT</i> (1. rPT)	P. 38
Input 2_proportional band	<i>2 P</i> (2. P)	P. 37
Input 2_integral time	<i>2 I</i> (2. I)	P. 37
Input 2_derivative time	<i>2 d</i> (2. d)	P. 37
Input 2_control response parameter	<i>2 rPT</i> (2. rPT)	P. 38

Parameter		Page
Input 1_setting change rate limiter (up)	<i>1SVrU</i> (1.SVrU)	P. 38
Input 1_setting change rate limiter (down)	<i>1SVrd</i> (1.SVrd)	P. 39
Input 2_setting change rate limiter (up)	<i>2SVrU</i> (2. SVrU)	P. 38
Input 2_setting change rate limiter (down)	<i>2SVrd</i> (2.SVrd)	P. 39
Area soak time	<i>AST</i> (AST)	P. 40
Link area number	<i>LnKA</i> (LnKA)	P. 41

■ LBA deadband (Lbd1, Lbd2)

The LBA deadband gives a neutral zone to prevent the Control loop break alarm (LBA) from malfunctioning caused by disturbance.

Data range: 0.0 to Input span
(Varies with the setting of the Decimal point position)

Factory set value: 0.0

LBA Deadband function:

The LBA may malfunction due to external disturbances. To prevent malfunctioning due to external disturbance, LBA deadband (LBD) sets a neutral zone in which LBA is not activated. When the Measured value (PV) is within the LBD area, LBA will not be activated. If the LBD setting is not correct, the LBA will not work correctly.

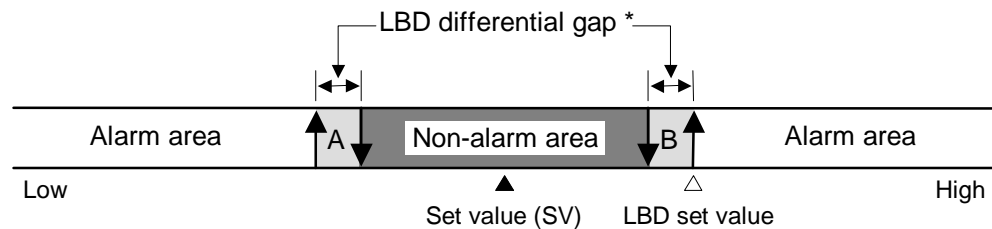

* TC/RTD input: 0.8 °C [°F] (fixed)

Pressure sensor input and Voltage/Current input: 0.8 % of input span (fixed)

A:	During temperature rise:	Alarm area
	During temperature fall:	Non-alarm area
B:	During temperature rise:	Non-alarm area
	During temperature fall:	Alarm area



If the LBA function detects an error occurring in the control loop, but cannot specify the location, a check of the control loop in order. The LBA function does not detect a location which causes alarm status. If LBA alarm is ON, check each device or wiring of the control loop.



LBA function is not operative when:

- AT function is activated.
- The controller is in STOP mode.
- LBA function is set to "OFF."
- LBA function is not assigned to Event (ES3) or Event 4 (ES4).



If the LBA time is too short or does not match the controlled object requirements, LBA may turn ON or OFF at inappropriate time or remain OFF. Change the LBA time based on the malfunction.



While the LBA is ON (under alarm status), the following conditions cancel the alarm status and LBA will be OFF:

- The Measured value (PV) rises beyond (or falls below) the LBA determination range within the LBA time.
- The Measured value (PV) enter within the LBA deadband.

■ Proportional band (1. P, 2. P) for PI/PID control

Data range: Pressure sensor input: 0.0 to 1000.0 % of input span
TC/RTD inputs: 0 (0.0, 0.00) to Input span (Unit: °C [°F])
(Varies with the setting of the Decimal point position)
Voltage (V)/Current (I) inputs: 0.0 to 1000.0 % of input span
0 (0.0, 0.00): ON/OFF action

Factory set value: Input 1_proportional band (1. P): 100.0
Input 2_proportional band (2. P): 30.0

Related parameters: ON/OFF action differential gap (upper/lower) (P. 88)

■ Integral time (1. I, 2. I) for PI/PID control

Integral action is to eliminate offset between SV and PV by proportional action. The degree of Integral action is set by time in seconds.

Data range: OFF (PD action),
1 to 3600 seconds, 0.1 to 3600.0 seconds, or 0.01 to 360.00 seconds
(Varies with the setting of the Integral/Derivative time decimal point position selection)

Factory set value: Input 1_integral time (1. I): 5.00
Input 2_integral time (2. I): 240.00

Related parameters: Integral/Derivative time decimal point position selection (P. 87)

■ Derivative time (1. d, 2. d) for PID control

Derivative action is to prevent rippling and make control stable by monitoring output change. The degree of Derivative action is set by time in seconds.

Data range: OFF (PI action),
1 to 3600 seconds, 0.1 to 3600.0 seconds, or 0.01 to 360.00 seconds
(Varies with the setting of the Integral/Derivative time decimal point position selection)

Factory set value: Input 1_derivative time (1. d): OFF (PI action)
Input 2_derivative time (2. d): 60.00

Related parameters: Integral/Derivative time decimal point position selection (P. 87)

■ Control response parameter (1. rPT, 2. rPT)

The control response for the Set value (SV) change can be selected among Slow, Medium, and Fast.

Data range: 0: Slow

1: Medium

2: Fast

Factory set value: Input 1_control response parameter (1. rPT): 0

Input 2_control response parameter (2. rPT): 0

Control Response: The control response for the Set value (SV) change can be selected among Slow, Medium, and Fast. If a fast response is required, Fast is chosen. Fast may cause overshoot. If overshoot is critical, Slow is chosen.

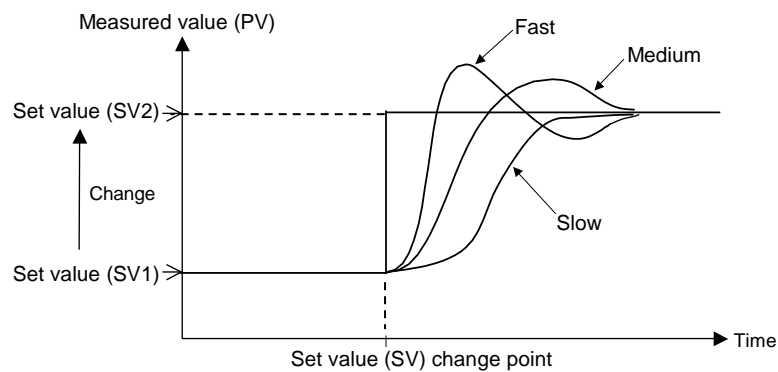

■ Setting change rate limiter (up) (1.SVrU, 2.SVrU)

This function is to allow the Set value (SV) to be automatically changed at specific rates when a new Set value (SV). SVrU is used when the SV is changed to a higher SV.

Data range: OFF (Unused)

0.1 to Input span/unit time

(Varies with the setting of the Decimal point position)

Factory set value: Input 1_setting change rate limiter (up) (1.SVrU): OFF

Input 2_setting change rate limiter (up) (2.SVrU): OFF



The unit time can be changed by the Setting change rate limiter unit time in the Engineering mode (P. 97). (Factory set value: 60 seconds)

■ Setting change rate limiter (down) (1.SVrd, 2.SVrd)

This function is to allow the Set value (SV) to be automatically changed at specific rates when a new Set value (SV). SVrd is used when the SV is changed to a lower SV.

Data range: OFF (Unused)
0.1 to Input span/unit time
(Varies with the setting of the Decimal point position)

Factory set value: Input 1_setting change rate limiter (down) (1.SVrd): OFF
Input 2_setting change rate limiter (down) (2.SVrd): OFF

 The unit time can be changed by the Setting change rate limiter unit time in the Engineering mode (P. 97). (Factory set value: 60 seconds)

Setting change rate limiter:

Application examples of setting change rate limiter:

- Increasing the SV to a higher value

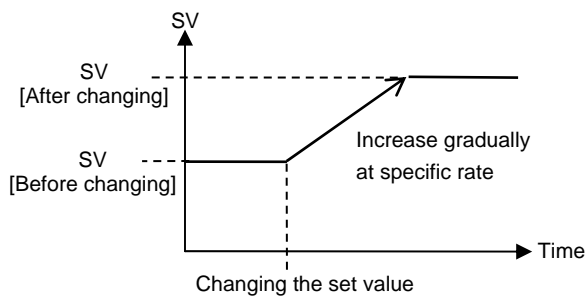

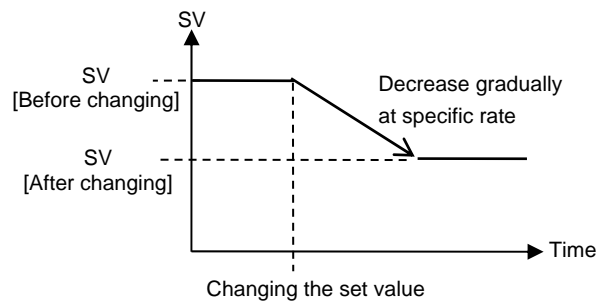

- Decreasing the SV to a lower value



 When the Setting change rate limiter is used, the SV will also ramp up or ramp down by the function at power-on and operation mode change from STOP to RUN.

 If the Autotuning (AT) function is activated while the SV is ramping up or ramping down by the Setting change rate limiter, AT will start after the SV finishes ramp-up or ramp-down by the limiter, and the controller is in PID control mode until AT starts.

 When the value of Setting change rate limiter is changed during normal operation, the ramp-up or ramp-down rate will be changed unless the SV already has finished ramp-up or ramp-down by the function.

 If the rate of Setting change limiter is set to any value other than "OFF (Unused)," the Event re-hold action to be taken by a Set value (SV) change becomes invalid.

■ Area soak time (AST)

Area soak time is used for Ramp/Soak control function in conjunction with Link area number and Setting change rate limiter (up/down).

Data range: 0 hour 00.00 second to 9 minutes 59.99 seconds or
0 hour 00 minute 00 second to 9 hours 59 minutes 59 seconds

Factory set value: 0.00.00 (0 minute 00.00 second)

Related parameters: Setting change rate limiter (up) (P. 38), Setting change rate limiter (down) (P. 39),
Link area number (P. 41), Memory area soak time monitor (P. 107)

 The unit time can be changed by the Soak time unit selection in the Engineering mode. (P. 97).
(Factory set value: 0 minute 00.00 second to 9 minutes 59.99 seconds)

 The Area soak time can be changed during normal operation with Ramp/Soak control function, but Read the following example carefully how the time change affects Ramp/Soak control time. For example, the memory area which has 5-minute soak time is executed. When 3 minutes passed, the Area soak time is changed from 5 minutes to 10 minutes. The remaining time of the currently executed Memory area is calculated as follows.
(The new soak time 10 minutes) – (lapsed time 3 minutes) = (remaining time 7 minutes)
The old soak time does not have any effect on remaining time.

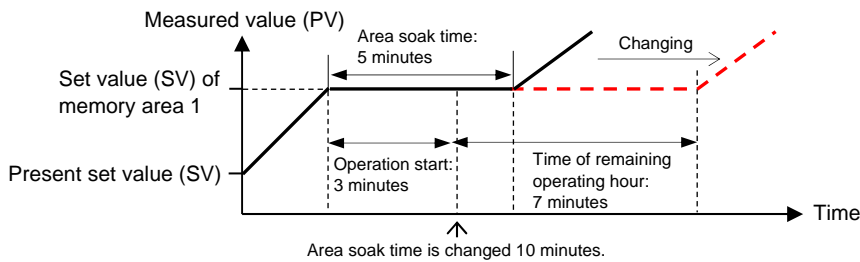

 For the instrument with the 2-input specification, its area soaking starts based on the arrival at the memory area set value of Input 1 or that of Input 2, whichever later.

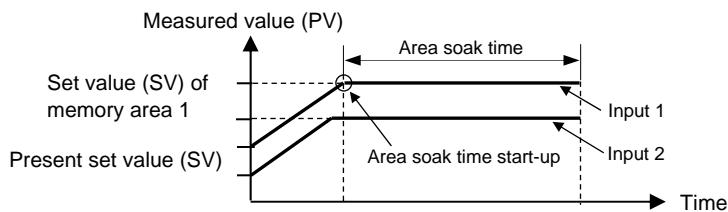

■ Link area number (LnKA)

Link area number is used for Ramp/Soak control function in conjunction with Area soak time and Setting change rate limiter (up/down).

Data range: OFF (No link)
1 to 16

Factory set value: OFF

Related parameters: Setting change rate limiter (up) (P. 38), Setting change rate limiter (down) (P. 39),
Area soak time (P. 40), Memory area soak time monitor (P. 107)

Ramp/Soak Control Function:

Ramp/Soak control is possible by using Area soak time, Link area number and Setting change rate limiter (up/down) in Parameter setting mode.

[Usage example]

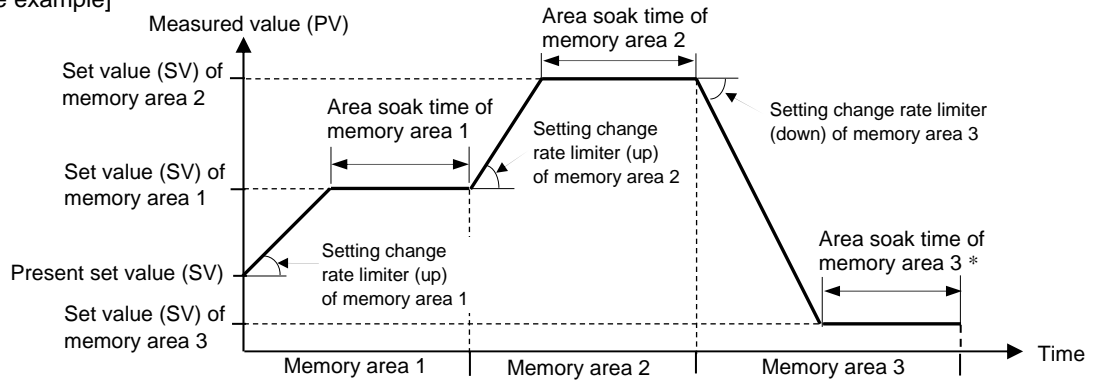

* The Area soak time for the memory area linked last becomes invalid to continue the state of the Set value (SV) reached.

7. SETUP SETTING MODE

7.1 Display Sequence

In Setup setting mode, the following operations are possible.

- Change other operation/control related parameters
- Change Communication parameters
- Change Data lock level

To go to Setup setting mode from SV setting & Monitor mode, press the shift key while pressing the SET key.

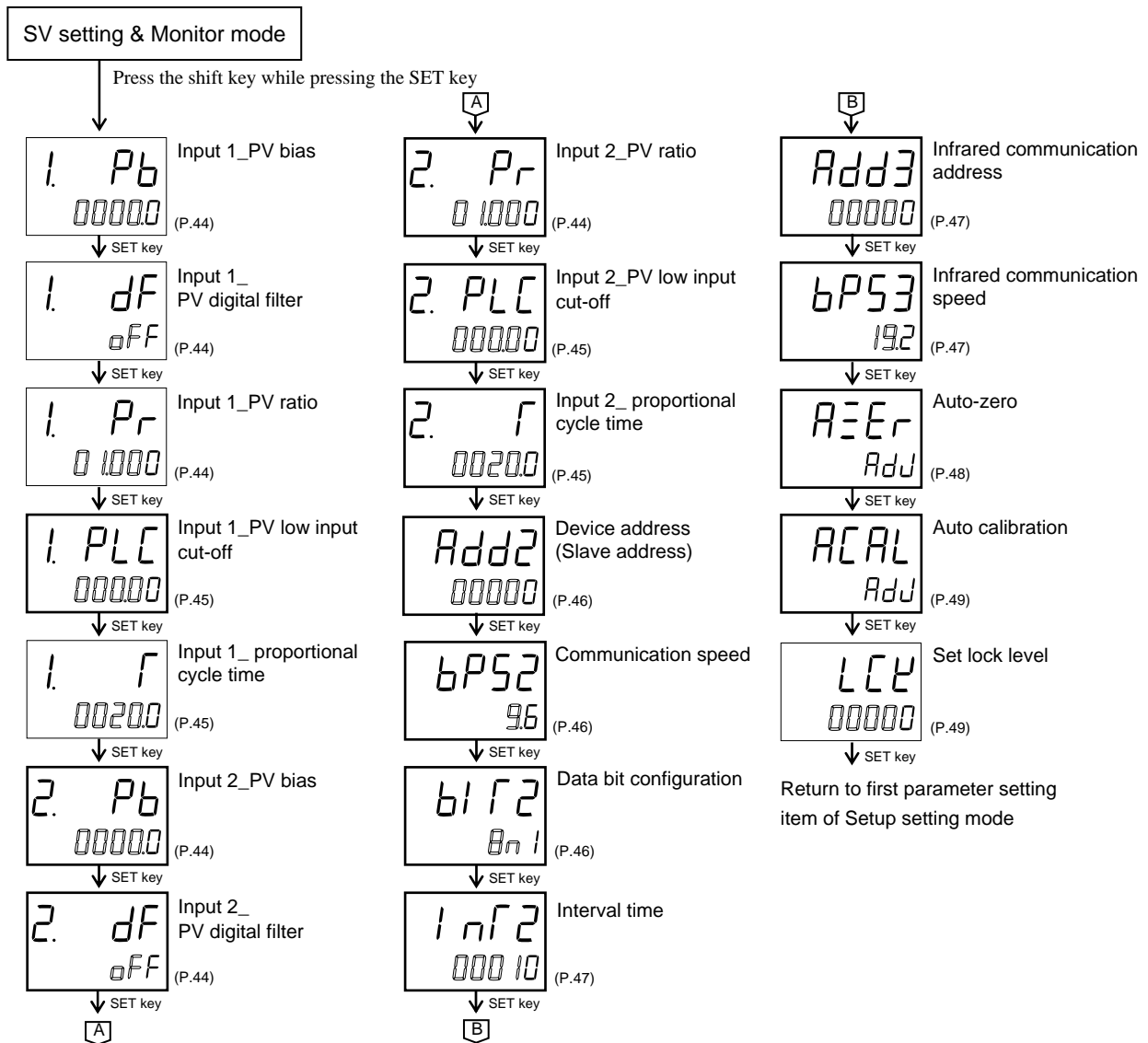

 : Parameters displayed when function is specified.



Parameters which are not related to existing functions on the controller are not displayed.

To return the SV setting & Monitor mode, press the shift key while pressing the SET key.

This instrument returns to the PV1/SV1 monitor screen if no key operation is performed within 1 minute.

7.2 Parameter List

Parameter		Page
Input 1_PV bias	<i>1 Pb</i> (1. Pb)	P. 44
Input 1_PV digital filter	<i>1 dF</i> (1. dF)	P. 44
Input 1_PV ratio	<i>1 Pr</i> (1. Pr)	P. 44
Input 1_PV low input cut-off	<i>1 PLC</i> (1. PLC)	P. 45
Input 1_ proportional cycle time	<i>1 T</i> (1. T)	P. 45
Input 2_PV bias	<i>2 Pb</i> (2. Pb)	P. 44
Input 2_PV digital filter	<i>2 dF</i> (2. dF)	P. 44
Input 2_PV ratio	<i>2 Pr</i> (2. Pr)	P. 44
Input 2_PV low input cut-off	<i>2 PLC</i> (2. PLC)	P. 45
Input 2_ proportional cycle time	<i>2 T</i> (2. T)	P. 45
Device address (Slave address)	<i>Add2</i> (Add2)	P. 46
Communication speed	<i>bPS2</i> (bPS2)	P. 46
Data bit configuration	<i>bit2</i> (bIT2)	P. 46
Interval time	<i>Int2</i> (InT2)	P. 47
Infrared communication address	<i>Add3</i> (Add3)	P. 47
Infrared communication speed	<i>bPS3</i> (bPS3)	P. 47

Parameter		Page
Auto-zero	<i>AZE</i> (AZEr)	P. 48
Auto calibration	<i>ACAL</i> (ACAL)	P. 49
Set lock level	<i>LCK</i> (LCK)	P. 49

7.3 Description of Each Parameter

■ PV bias (1. Pb, 2. Pb)

PV bias adds bias to the Measured value (PV). The PV bias is used to compensate the individual variations of the sensors or correct the difference between the Measured value (PV) of other instruments.

Data range: –Input span to +Input span

Factory set value: Input 1_PV bias (1. Pb): 0
 Input 2_PV bias (2. Pb): 0

Related parameter: Auto-zero (P. 48)



The Input 1_PV bias (1. Pb) value is also reflected to the result of Auto-zero adjustment. Manual zero adjustment can be performed by changing this PV bias value.*

* Relevant pressure sensors: Our CZ-100P or CZ-200P

■ PV digital filter (1. dF, 2. dF)

This item is the time of the first-order lag filter eliminate noise against the measured input.

Data range: OFF (Unused)
 0.01 to 10.00 seconds

Factory set value: Input 1_PV digital filter (1. dF): OFF
 Input 2_PV digital filter (2. dF): OFF

■ PV ratio (1. Pr, 2. Pr)

PV ratio is a multiplier to be applied to the Measured value (PV). The PV ratio is used to compensate the individual variations of the sensors or correct the difference between the Measured value (PV) of other instruments.

Data range: 0.500 to 1.500

Factory set value: Input 1_PV ratio (1. Pr): 1.000
 Input 2_PV ratio (2. Pr): 1.000

Related parameter: Auto calibration (P. 49)



When using our CZ-100P or CZ-200P:

- Explosionproof specification type:
Set the desired correction factor of our safety barrier RZB-001 to the Input 1_PV ratio (1. Pr). Thus, an indicated error caused by the use of the safety barrier is corrected. The correction factor is described in the nameplate attached to the safety barrier (RZB-001).
- Non-explosionproof specification type:
As the Input 1_PV ratio (1. Pr), use a factory set value of “1.000” with this value left intact.



When using the strain gauge type sensors other than RKC product:

The result obtained by Auto calibration is reflected to the Input 1_PV ratio (1. Pr).
Manual full scale adjustment can be performed by changing this PV ratio value.

■ PV low input cut-off (1. PLC, 2. PLC)

PV low input cut-off is used with Square root extraction function. The measured value less than the PV low input cut-off is ignored to prevent control disturbance caused by input variation at low measured value range.

Data range: 0.00 to 25.00 % of input span

Factory set value: Input 1_PV low input cut-off: (1. PLC): 0.00

Input 2_PV low input cut-off: (2. PLC): 0.00

Related parameters: Square root extraction selection (P. 72)

PV low input cut-off function:

When input signal square root extraction is used for in flow control, etc., the Square root extraction result varies widely at the low measured value range. The measured value less than the PV low input cut-off is ignored to calculate control output in order to prevent control disturbance caused by input variation at low measured value range.

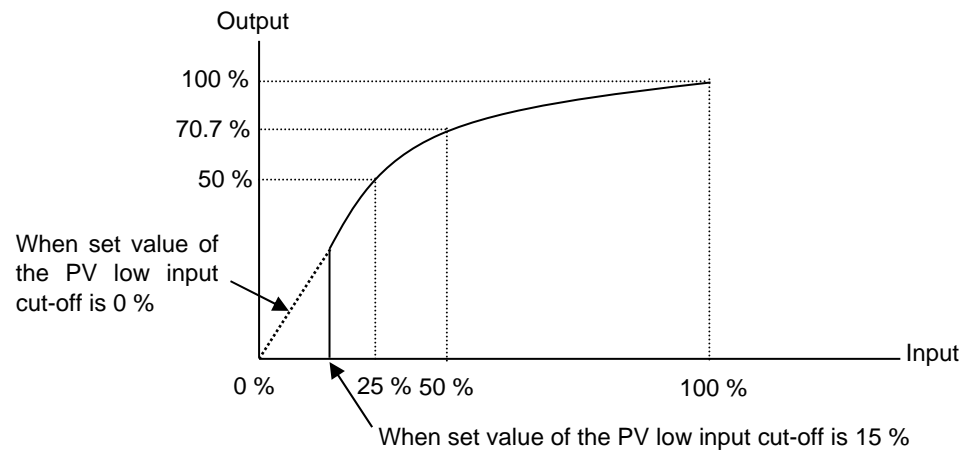

■ Proportional cycle time (1. T, 2. T)

Proportional cycle time is to set control cycle time for time based control output such as voltage pulse for SSR, triac and relay output.

Data range: 0.1 to 100.0 seconds

Factory set value: Input 1_proportional cycle time (1. T):

Relay contact output: 20.0 seconds

Voltage pulse output and triac output: 2.0 seconds

Input 2_proportional cycle time (2. T):

Relay contact output: 20.0 seconds

Voltage pulse output and triac output: 2.0 seconds



The Proportional cycle time becomes invalid when the Voltage/Current output is selected as control output type.

■ **Device address (Slave address) (Add2)**

Device address is used to set the Slave address of the controller for Communication function (optional).

Data range: 0 to 99 (RKC communication, Modbus)
 0 to 63 (DeviceNet)
 0 to 64 (CC-Link: 1 station occupied 1 time, 1 station occupied 4 times, 1 station occupied 8 times)
 0 to 126 (PROFIBUS)
 1 to 61 (CC-Link: 4 stations occupied 1 time)

Factory set value: 0



Do not use the same device address for more than one controller in multi-drop connection. Each controller must have a unique address in multi-drop connection.



In Modbus and PROFIBUS and CC-Link communications, two-way communications are not possible when the addresses are 0.

■ **Communication speed (bPS2)**

Communication speed is to set communication speed for Communication function (optional).

Data range: 2.4: 2400 bps 125: 125 kbps ¹ 156: 156 kbps ²
 4.8: 4800 bps 250: 250 kbps ¹ 625: 625 kbps ²
 9.6: 9600 bps 500: 500 kbps ¹ 2500: 2.5 Mbps ²
 19.2: 19200 bps 5000: 5 Mbps ²
 38.4: 38400 bps 10000: 10 Mbps ²

¹ A communication speed of 125 to 500 kbps can be selected for DeviceNet.

² A communication speed of 156 kbps, 625 kbps, and 2.5 to 10 Mbps can be selected for CC-Link.

Factory set value: 9.6 (RKC communication, Modbus)
 125 (DeviceNet)
 156 (CC-Link)



Set the same communication speed for both the HA430/930 (slave) and the host computer (master).



Communication speed is not necessary to be selected for PROFIBUS.

■ **Data bit configuration (bIT2)**

This item is Data bit configuration of Communication function (optional).

Data range: Refer to below

[Data bit configuration table]

Set value	Data bit	Parity bit	Stop bit
8n1 (8n1)	8	Without	1
8n2 (8n2)	8	Without	2
8E1 (8E1)	8	Even	1
8E2 (8E2)	8	Even	2
8o1 (8o1)	8	Odd	1
8o2 (8o2)	8	Odd	2
7n1 (7n1)*	7	Without	1
7n2 (7n2)*	7	Without	2
7E1 (7E1)*	7	Even	1
7E2 (7E2)*	7	Even	2
7o1 (7o1)*	7	Odd	1
7o2 (7o2)*	7	Odd	2

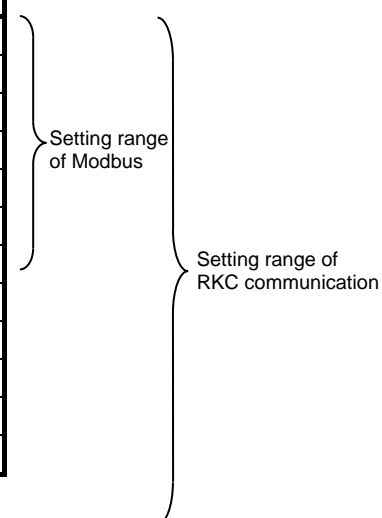

* When the Modbus communication protocol selected, this setting becomes invalid.

Factory set value: 8n1 (Data bit: 8, Parity bit: Without, Stop bit: 1)



Data bit configuration is not necessary to be selected for PROFIBUS, DeviceNet and CC-Link.

■ Interval time (InT2)

This item is Interval time of Communication function (optional).

Data range: 0 to 250 ms

Factory set value: 10

Interval Time function: The interval time for the HA430/930 should be set to provide a time for host computer to finish sending all data including stop bit and switch the line to receive status for the host.



If the Interval time between the two is too short, the HA430/930 may send data before the host computer is ready to receive it. In this case, communication transmission cannot be conducted correctly. For a successful communication sequence to occur, the HA430's or HA930's interval time must match the specifications of the host computer.

■ Infrared communication address (Add3)

Infrared communication address is used to set the device address of the controller for Infrared communication function.

Data range: 0 to 99

Factory set value: 0

■ Infrared communication speed (bPS3)

This item is communication speed of the Infrared communication function.

Data range: 9.6: 9600 bps

19.2: 19200 bps

Factory set value: 19.2



The factory set value of the Infrared communication speed of your PDA's * is 19200 bps.



Data bit, Stop bit and Parity bit on this controller under Infrared communication are fixed to the following settings. The relevant bits on the PDA* are fixed to the same settings as on this controller prior to factory set value. Therefore do not change them at the site.

- Data bit: 7-bit
- Parity bit: Even
- Stop bit: 1-bit

* The PDA being used is necessary to be installed with the infrared communication software RKCIR.

■ Auto-zero (AZEr)

Adjust the zero point of the Measured value (PV1) on the Input 1 side.

Factory set value: —

Related parameters: PV bias (P. 44)

Adjustment procedure:

1. Make sure that the pressure sensor * is installed on the equipment.

 **3. Wiring (P. 13)**

* Relevant pressure sensors: Our CZ-100P or CZ-200P

2. Rise the temperature of the equipment installed with the pressure sensor up to the temperature during operation.
3. Set the pressure sensor to the no-load state.
4. Change the operation state to the control STOP.
5. Pressing the shift key for 1 second while displaying the Auto-zero screen automatically starts Auto-zero operation.

If this Auto-zero operation normally end, the screen returns to the Auto-zero screen.

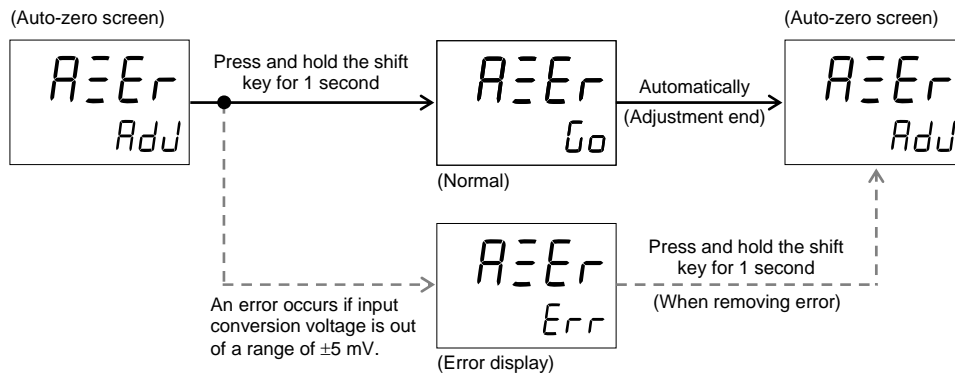

The result of Auto-zero adjustment is also reflected to the Input 1_PV bias (1. Pb) value. Manual zero point adjustment can be performed by changing this PV bias value.

■ Auto calibration (ACAL)

Adjust the full scale point of the Measured value (PV1) on the Input 1 side.

Factory set value: —

Related parameters: PV ratio (P. 44), Shunt resistance output value (P. 68)

Adjustment procedure:

1. Make sure that the pressure sensor * is installed on the equipment.

👉 3. Wiring (P. 13)

* Relevant pressure sensors: The strain gauge type sensors other than RKC product

2. Rise the temperature of the equipment installed with the pressure sensor up to the temperature during operation.
3. Change the operation state to the control STOP.
4. Pressing the shift key for 1 second while displaying the Auto calibration screen automatically starts Auto calibration operation. If this Auto calibration operation normally end, the screen returns to the Auto calibration screen.

📖 For this product, in order to generate the R-cal output it is not necessary to short the cables (blue and orange) on the pressure sensor side.

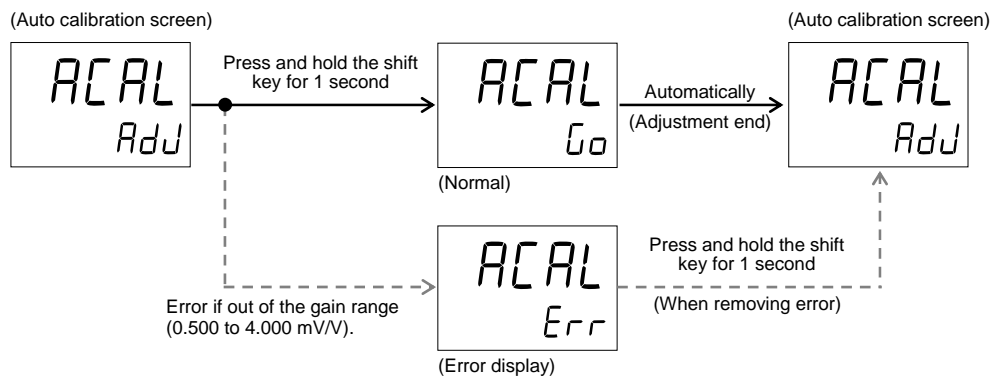

📖 The result obtained by Auto calibration is reflected to the Input 1_PV ratio (1. Pr) value. Manual full scale point adjustment can be performed by changing this PV ratio value.

■ Set lock level (LCK)

The Set lock level restricts parameter setting changes by key operation (Set data lock function).

This function prevents the operator from making errors during operation.

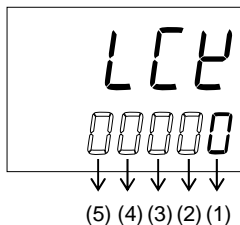

Data range:

(1) Parameters other than Set value (SV) and Event set value (EV1 to EV4):

0: Unlock 1: Lock

(2) Event set value (EV1 to EV4)

0: Unlock 1: Lock

(3) Set value (SV)

0: Unlock 1: Lock

(4) "0" Fixed (No setting)

(5) "0" Fixed (No setting)

Factory set value: 00000

📖 In the Set lock level, Data lock is not possible for the following parameters.

- Memory area selection (SV setting & Monitor mode),
- Parameters of function block number F10 to F91 (Engineering mode)



📖 Set lock level can be changed in both RUN and STOP mode.

📖 Parameters protected by Data lock function are still displayed for monitoring.

8. ENGINEERING MODE

⚠ WARNING

Parameters in the Engineering mode should be set according to the application before setting any parameter related to operation. Once the Parameters in the Engineering mode are set correctly, no further changes need to be made to parameters for the same application under normal conditions. If they are changed unnecessarily, it may result in malfunction or failure of the instrument. RKC will not bear any responsibility for malfunction or failure as a result of improper changes in the Engineering mode.

-  Parameters in Engineering mode are settable only when the controller is in STOP mode.
-  Function blocks and setting items which do not exist in the HA430/930 are displayed on the screen of the shaded section. For these functions blocks and setting items, use their factory set values with these values left intact.
-  All parameters of the engineering mode are displayed regardless of the instrument specification.

8.1 Display Sequence

To go to Engineering mode, press the shift key for 2 seconds while pressing the SET key at SV setting & Monitor mode, Parameter setting mode, or Setup setting mode.

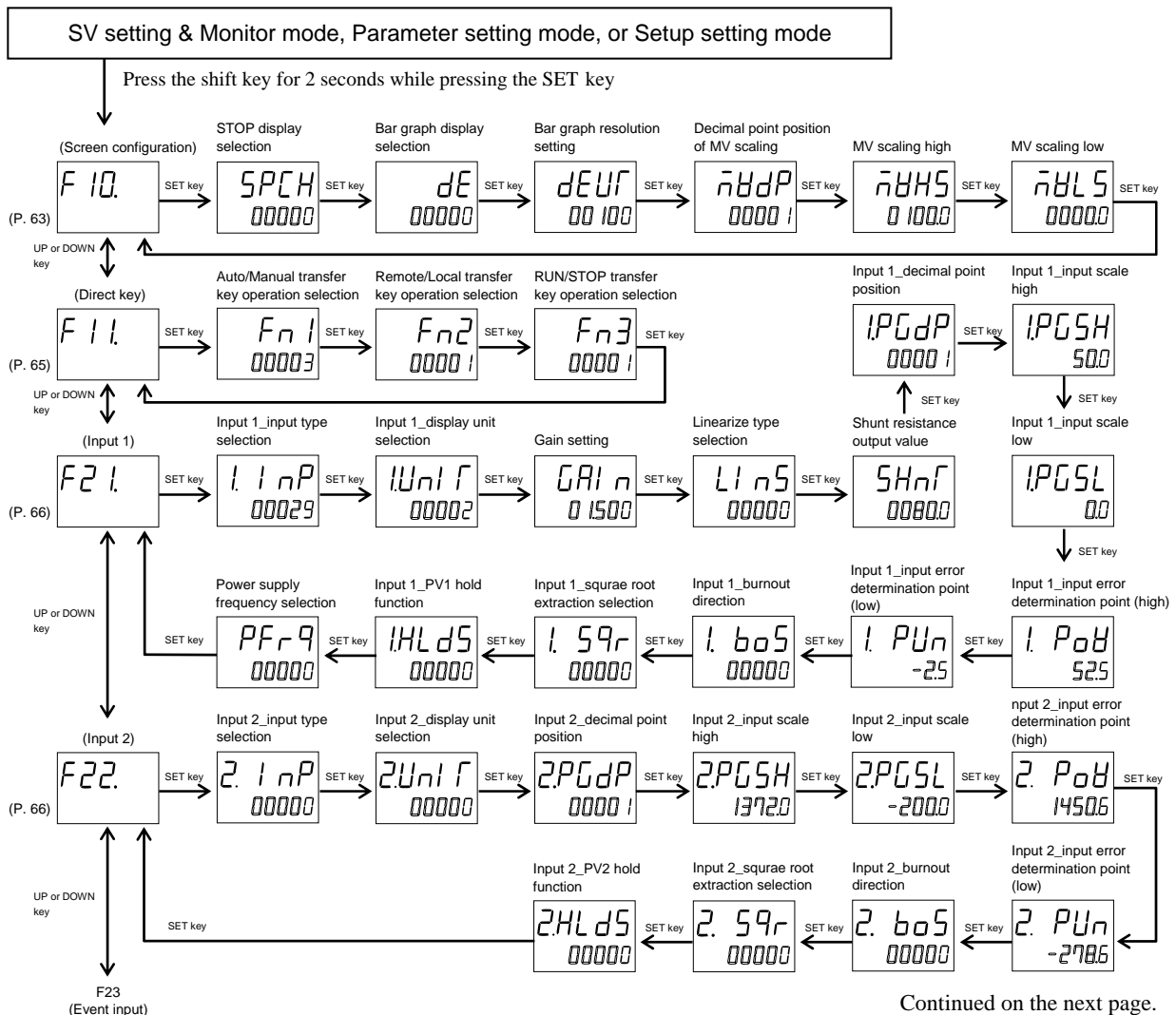

Continued from the previous page.

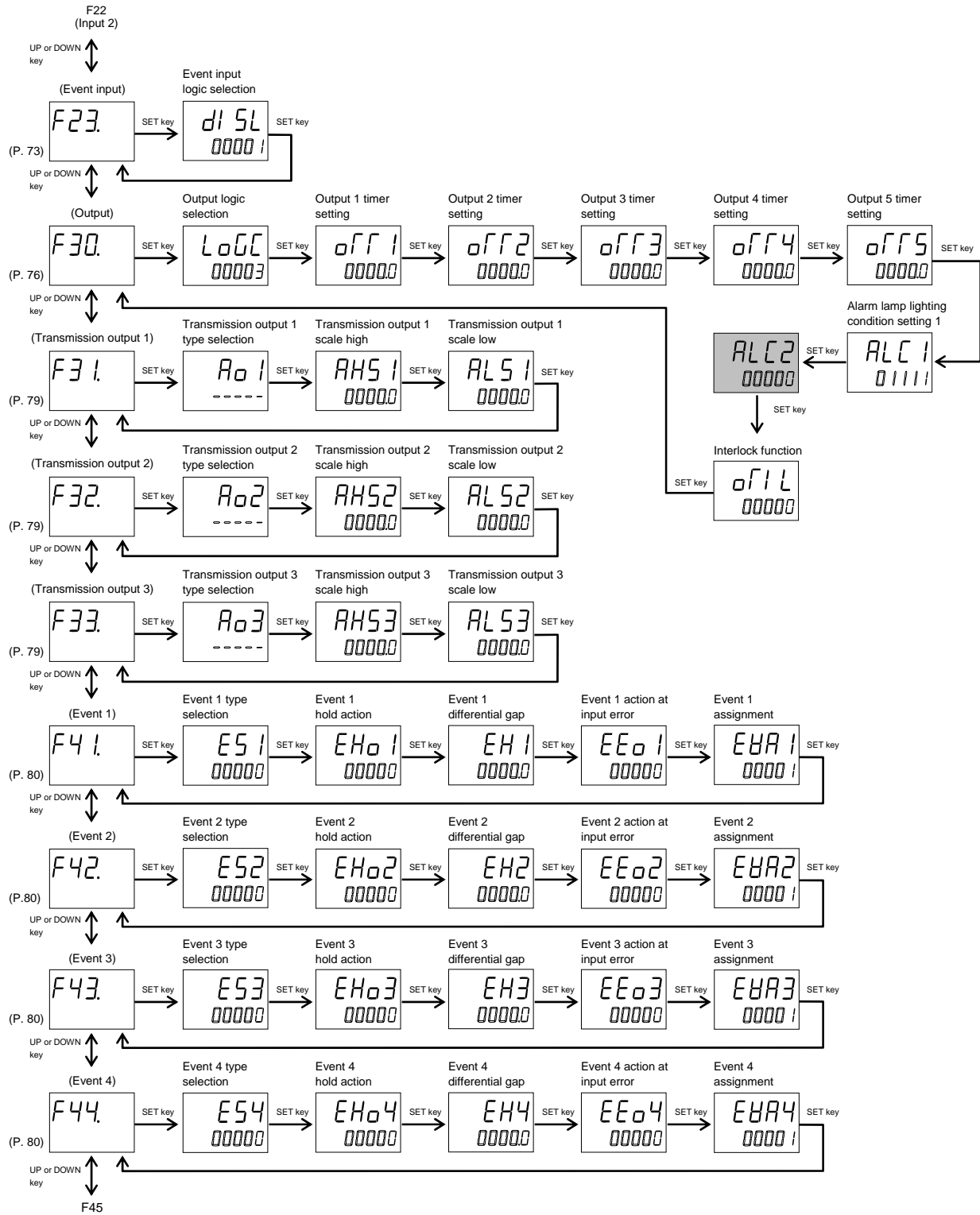

Continued on the next page.

Continued from the previous page.

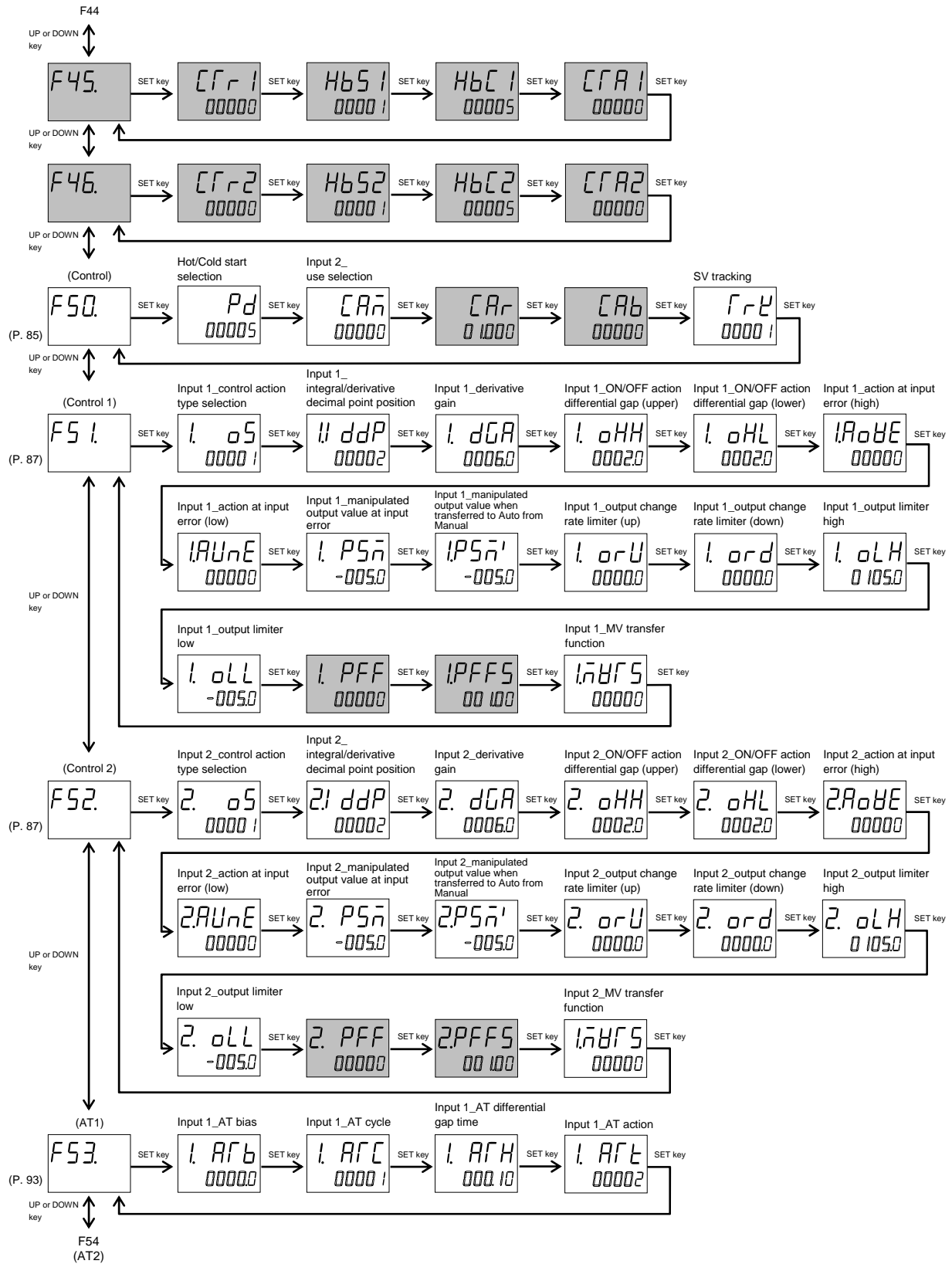

Continued on the next page.

Continued from the previous page.

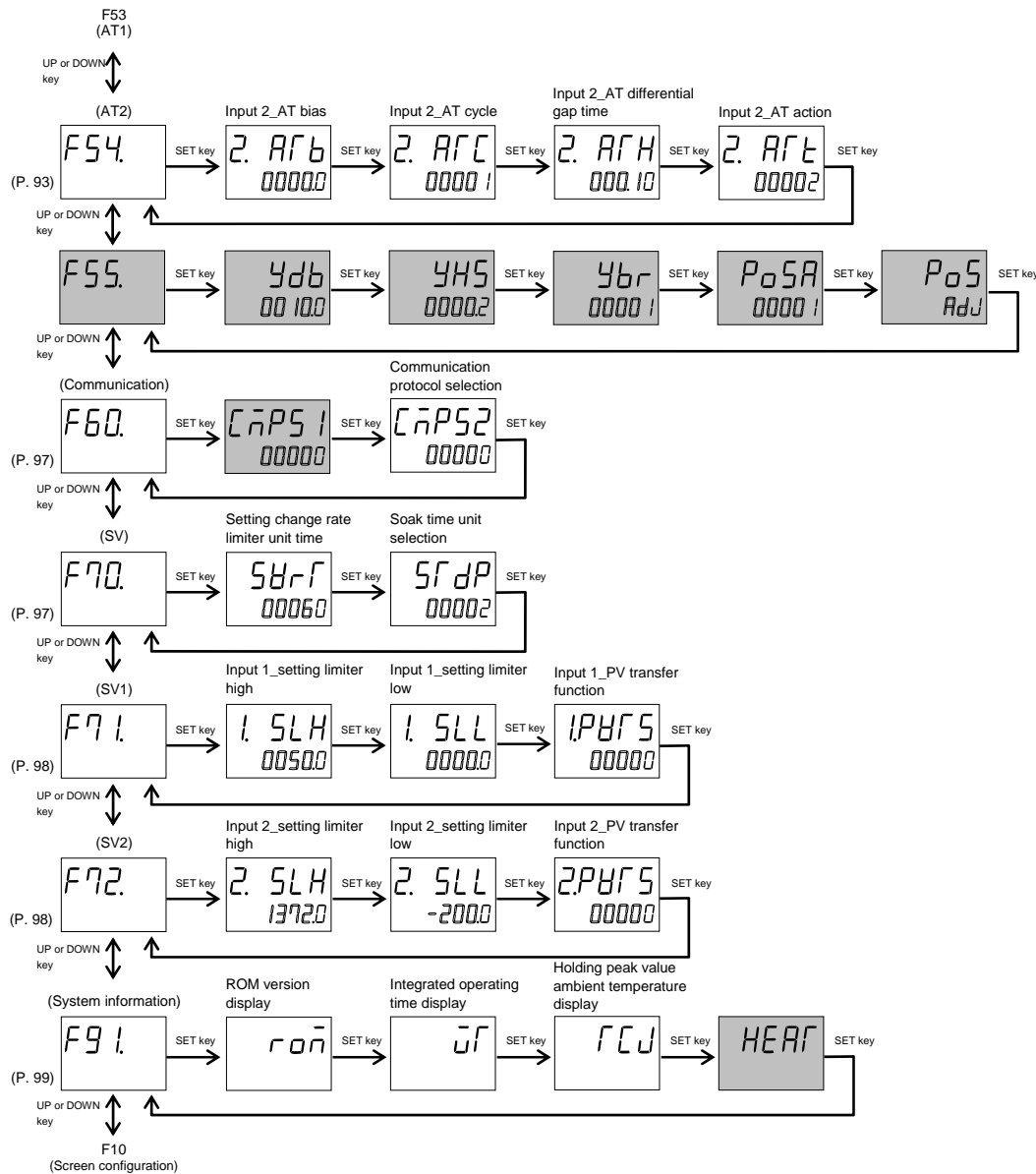

To return to the SV setting & Monitor mode, press and hold the SET key for 2 seconds, or press the shift key while pressing the SET key.



If the key is not pressed within 1 minute, the display will automatically return to the SV setting & Monitor mode.

8.2 Parameter List

Function block		Parameter		Page
F10. (F10.)	Screen configuration	STOP display selection	SPCH (SPCH)	P. 63
		Bar graph display selection	dE (dE)	
		Bar graph resolution setting	dEUR (dEUR)	P. 64
		Decimal point position of MV scaling	nBdP (MVdP)	
		MV scaling high	nBHS (MVHS)	
		MV scaling low	nBLS (MVLS)	P. 65
F11. (F11.)	Direct key	Auto/Manual transfer key operation selection	Fn1 (Fn1)	P. 65
		Remote/Local transfer key operation selection	Fn2 (Fn2)	
		RUN/STOP transfer key operation selection	Fn3 (Fn3)	
F21. (F21.)	Input 1	Input 1_input type selection	1.1nP (1.InP)	P. 66
		Input 1_display unit selection	1.UnIT (1.UnIT)	P. 67
		Gain setting	GAI n (GAI n)	P. 68
		Linearize type selection	LI nS (LI nS)	
		Shunt resistance output value	SHnT (SHnT)	
		Input 1_decimal point position	1.PGdP (1.PGdP)	P. 69
		Input 1_input scale high	1.PGSH (1.PGSH)	
		Input 1_input scale low	1.PGSL (1.PGSL)	P. 70
		Input 1_input error determination point (high)	1.PoH (1.PoV)	P. 71
		Input 1_input error determination point (low)	1.PUn (1.PUn)	
		Input 1_burnout direction	1.boS (1.boS)	
		Input 1_square root extraction selection	1.SQR (1.SQR)	P. 72
		Input 1_PV1 hold function	1.HLdS (1.HLdS)	
		Power supply frequency selection	PFRq (PFRq)	
F22. (F22.)	Input 2	Input 2_input type selection	2.1nP (2.InP)	P. 66
		Input 2_display unit selection	2.UnIT (2.UnIT)	P. 67
		Input 2_decimal point position	2.PGdP (2.PGdP)	P. 69
		Input 2_input scale high	2.PGSH (2.PGSH)	
		Input 2_input scale low	2.PGSL (2.PGSL)	P. 70
		Input 2_input error determination point (high)	2.PoH (2.PoV)	P. 71
		Input 2_input error determination point (low)	2.PUn (2.PUn)	
		Input 2_burnout direction	2.boS (2.boS)	
		Input 2_square root extraction selection	2.SQR (2.SQR)	P. 72
		Input 2_PV2 hold function	2.HLdS (2.HLdS)	

Continued on the next page.

Continued from the previous page.

Function block		Parameter		Page
<i>F23</i> (F23.)	Event input	Event input logic selection	<i>dI SL</i> (dISL)	P. 73
<i>F30</i> (F30.)	Output	Output logic selection	<i>LoGC</i> (LoGC)	P. 76
		Output 1 timer setting	<i>oTT1</i> (oTT1)	P. 77
		Output 2 timer setting	<i>oTT2</i> (oTT2)	
		Output 3 timer setting	<i>oTT3</i> (oTT3)	
		Output 4 timer setting	<i>oTT4</i> (oTT4)	
		Output 5 timer setting	<i>oTT5</i> (oTT5)	
		Alarm lamp lighting condition setting 1	<i>ALC1</i> (ALC1)	—
		This item is not used for the HA430/930.	<i>ALC2</i> (ALC2)	
		Interlock function	<i>oTIL</i> (oTIL)	P. 78
<i>F31</i> (F31.)	Transmission output 1	Transmission output 1 type selection	<i>AO1</i> (Ao1)	P. 79
		Transmission output 1 scale high	<i>AHS1</i> (AHS1)	
		Transmission output 1 scale low	<i>ALS1</i> (ALS1)	
<i>F32</i> (F32.)	Transmission output 2	Transmission output 2 type selection	<i>AO2</i> (Ao2)	P. 79
		Transmission output 2 scale high	<i>AHS2</i> (AHS2)	
		Transmission output 2 scale low	<i>ALS2</i> (ALS2)	
<i>F33</i> (F33.)	Transmission output 3	Transmission output 3 type selection	<i>AO3</i> (Ao3)	P. 79
		Transmission output 3 scale high	<i>AHS3</i> (AHS3)	
		Transmission output 3 scale low	<i>ALS3</i> (ALS3)	
<i>F41</i> (F41.)	Event 1	Event 1 type selection	<i>ES1</i> (ES1)	P. 80
		Event 1 hold action	<i>EHo1</i> (EHo1)	P. 82
		Event 1 differential gap	<i>EH1</i> (EH1)	P. 83
		Event 1 action at input error	<i>EEo1</i> (EEo1)	P. 84
		Event 1 assignment	<i>EVA1</i> (EVA1)	
<i>F42</i> (F42.)	Event 2	Event 2 type selection	<i>ES2</i> (ES2)	P. 80
		Event 2 hold action	<i>EHo2</i> (EHo2)	P. 82
		Event 2 differential gap	<i>EH2</i> (EH2)	P. 83
		Event 2 action at input error	<i>EEo2</i> (EEo2)	P. 84
		Event 2 assignment	<i>EVA2</i> (EVA2)	
<i>F43</i> (F43.)	Event 3	Event 3 type selection	<i>ES3</i> (ES3)	P. 80
		Event 3 hold action	<i>EHo3</i> (EHo3)	P. 82
		Event 3 differential gap	<i>EH3</i> (EH3)	P. 83
		Event 3 action at input error	<i>EEo3</i> (EEo3)	P. 84
		Event 3 assignment	<i>EVA3</i> (EVA3)	

Continued on the next page.

Continued from the previous page.

Function block		Parameter		Page
F44. (F44.)	Event 4	Event 4 type selection	ES4 (ES4)	P. 80
		Event 4 hold action	EHo4 (EHo4)	P. 82
		Event 4 differential gap	EH4 (EH4)	P. 83
		Event 4 action at input error	EEo4 (EEo4)	P. 84
		Event 4 assignment	EVA4 (EVA4)	
F45. (F45.)	These are function blocks unused in the HA430/930. (Their settings are invalid)			
F46. (F46.)	These are function blocks unused in the HA430/930. (Their settings are invalid)			
F50. (F50.)	Control	Hot/Cold start selection	Pd (Pd)	P. 85
		Input 2_use selection	CAn (CAM)	
		These items are not used for the HA430/930.	CAr (CAr)	—
			CAb (CAb)	—
		SV tracking	TrK (TrK)	P. 86
F51. (F51.)	Control 1	Input 1_control action type selection	1. oS (1. oS)	P. 87
		Input 1_integral/derivative decimal point position	1. ddp (1. ddp)	
		Input 1_derivative gain	1. dGA (1. dGA)	
		Input 1_ON/OFF action differential gap (upper)	1. oHH (1. oHH)	P. 88
		Input 1_ON/OFF action differential gap (lower)	1. oHL (1. oHL)	
		Input 1_action at input error (high)	1. AoHE (1. AoHE)	P. 89
		Input 1_action at input error (low)	1. AUHE (1. AUHE)	
		Input 1_manipulated output value at input error	1. PSm (1. PSM)	P. 90
		Input 1_manipulated output value when transferred to Auto from Manual	1. PSm' (1. PSM')	
		Input 1_output change rate limiter (up)	1. orU (1. orU)	P. 91
		Input 1_output change rate limiter (down)	1. ord (1. ord)	
		Input 1_output limiter high	1. oLH (1. oLH)	P. 92
		Input 1_output limiter low	1. oLL (1. oLL)	
		These items are not used for the HA430/930.	1. PFF (1. PFF)	—
			1. PFFS (1. PFFS)	—
		Input 1_MV transfer function	1. MVTS (1. MVTS)	P. 92
F52. (F52.)	Control 2	Input 2_control action type selection	2. oS (2. oS)	P. 87
		Input 2_integral/derivative decimal point position	2. ddp (2. ddp)	
		Input 2_derivative gain	2. dGA (2. dGA)	
		Input 2_ON/OFF action differential gap (upper)	2. oHH (2. oHH)	P. 88
		Input 2_ON/OFF action differential gap (lower)	2. oHL (2. oHL)	
		Input 2_action at input error (high)	2. AoHE (2. AoHE)	P. 89

Continued on the next page.

Continued from the previous page.

Function block		Parameter	Page
F52. (F52.)	Control 2	Input 2_action at input error (low)	2.AUnE (2.AUnE) P. 89
		Input 2_manipulated output value at input error	2.PSn (2.PSM) P. 90
		Input 2_manipulated output value when transferred to Auto from Manual	2.PSn' (2.PSM')
		Input 2_output change rate limiter (up)	2.orU (2.orU)
		Input 2_output change rate limiter (down)	2.ord (2.ord) P. 91
		Input 2_output limiter high	2.oLH (2.oLH) P. 92
		Input 2_output limiter low	2.oLL (2.oLL)
		These items are not used for the HA430/930.	2.PFF (2.PFF) —
			2.PFFS (2.PFFS) —
	Input 2_MV transfer function	2.nHFS (2.MVTS) P. 92	
F53. (F53.)	Autotuning 1 (AT1)	Input 1_AT bias	1.Afb (1.ATb) P. 93
		Input 1_AT cycle	1.AfC (1.ATC) P. 94
		Input 1_AT differential gap time	1.AfH (1.ATH) P. 95
		Input 1_AT action	1.AfE (1.ATu) P. 96
F54. (F54.)	Autotuning 2 (AT2)	Input 2_AT bias	2.Afb (2.ATb) P. 93
		Input 2_AT cycle	2.AfC (2.ATC) P. 94
		Input 2_AT differential gap time	2.AfH (2.ATH) P. 95
		Input 2_AT action	2.AfE (2.ATu) P. 96
F55. (F55.)	These are function blocks unused in the HA430/930. (Their settings are invalid)		
F60. (F60.)	Communication	This item is not used for the HA430/930.	CnPS1 (CMPS1) —
		Communication protocol selection	CnPS2 (CMPS2) P. 97
F70. (F70.)	Set value (SV)	Setting change rate limiter unit time	SVrT (SVrT) P. 97
		Soak time unit selection	STdP (STdP)
F71. (F71.)	Set value 1 (SV1)	Input 1_setting limiter high	1.SLH (1.SLH) P. 98
		Input 1_setting limiter low	1.SLL (1.SLL)
		Input 1_PV transfer function	1.PHFS (1.PVTS)
F72. (F72.)	Set value 2 (SV2)	Input 2_setting limiter high	2.SLH (2.SLH) P. 98
		Input 2_setting limiter low	2.SLL (2.SLL)
		Input 2_PV transfer function	2.PHFS (2.PVTS)
F91. (F91.)	System information	ROM version display	RoM (RoM) P. 99
		Integrated operating time display	WT (WT)
		Holding peak value ambient temperature display	TCJ (TCJ)
		This item is not used for the HA430/930.	HEAT (HEAT) —

8.3 Precaution Against Parameter Change

If any of the following parameters is changed, the set values of relevant parameters are initialized or is automatically converted according to the new setting. It may result in malfunction or failure of the instrument.

- Input Type Selection of Input 1 (1. InP)
- Input Type Selection of Input 2 (2. InP)
- Engineering Display Unit Selection of Input 1 (1.UnIT)
- Engineering Display Unit Selection of Input 2 (2.UnIT)
- Input 1_Decimal Point Position (1.PGdP)
- Input 2_Decimal Point Position (2.PGdP)
- Event 1 Type Selection (ES1)
- Event 2 Type Selection (ES2)
- Event 3 Type Selection (ES3)
- Event 4 Type Selection (ES4)
- Transmission Output 1 Type Selection (Ao1)
- Transmission Output 2 Type Selection (Ao2)
- Transmission Output 3 Type Selection (Ao3)



Before changing any parameter setting on the above list, always record all parameter settings in SV setting & Monitor mode, Setup setting mode, Parameter setting mode and Engineering mode. And after the change, always check all parameter settings in SV setting & Monitor mode, Setup setting mode, Parameter setting mode and Engineering mode by comparing them with the record taken before the change.

When any one of the following parameters' settings are changed,

- Input Type Selection of Input 1 (1. InP)
- Input Type Selection of Input 2 (2. InP)
- Engineering Display Unit Selection of Input 1 (1.UnIT)
- Engineering Display Unit Selection of Input 2 (2.UnIT)

all parameter settings shown in the table below will be changed to Factory Default Values according to the new setting. They must be changed according to the application.

Mode	Description	Default value			
		Pressure sensor input	TC input	RTD input	Voltage/current input
Engineering mode	Decimal point position	1 (One decimal place)			
	Input scale high	Maximum value of input range			100.0
	Input scale low	Minimum value of input range			0.0
	Input error determination point (high)	Maximum value of input range + (5 % of input span)			
	Input error determination point (low)	Minimum value of input range – (5 % of input span)			
	Burnout direction	0 (Upscale)			
	Transmission output 1 scale high	Measured value (PV) and Set value (SV): Input scale high Manipulated output value (MV): 100.0 Deviation: +Input span			
	Transmission output 2 scale high				
Transmission output 3 scale high					

Continued on the next page.

Continued from the previous page.

Mode	Description	Default value		
		Pressure sensor input	TC input	RTD input
Engineering mode	Transmission output 1 scale low	Measured value (PV) and Set value (SV): Input scale low Manipulated output value (MV): 0.0 Deviation: -Input span		
	Transmission output 2 scale low			
	Transmission output 3 scale low			
	Event 1 hold action	0 (Without hold action)		
	Event 2 hold action			
	Event 3 hold action			
	Event 4 hold action			
	Event 1 differential gap	2.0 MPa	2.0 °C [°F]	0.2 % of input span
	Event 2 differential gap			
	Event 3 differential gap			
	Event 4 differential gap			
	ON/OFF action differential gap (upper)	1.0 MPa	1.0 °C [°F]	0.1 % of input span
	ON/OFF action differential gap (lower)			
	AT bias	0		
Setting limiter high	Input scale high			
Setting limiter low	Input scale low			
Setup setting mode	PV bias	0		
	PV ratio	1.000		
	PV low input cut-off	0.00 %		
Parameter setting mode	Event 1 set value	50		
	Event 2 set value			
	Event 3 set value			
	Event 4 set value			
	Control loop break alarm1 (LBA1) time	480 seconds		
	Control loop break alarm2 (LBA2) time			
	LBA1 deadband	0.0		
	LBA2 deadband	0.0		
	Proportional band	30		
	Integral time	240.0 seconds		
	Derivative time	60.0 seconds		
	Control response parameter	0 (Slow)		
	Setting change rate limiter (up)	OFF (Unused)		
	Setting change rate limiter (down)			
SV setting & Monitor mode	Set value (SV)	0.0 MPa	0.0 °C [°F]	0.0 %

When any one of the following parameters' settings are changed,

- Event 1 Type Selection (ES1)
- Event 2 Type Selection (ES2)
- Event 3 Type Selection (ES3)
- Event 4 Type Selection (ES4)

all parameter settings shown in the table below will be changed to Factory Default Values according to the new setting. They must be changed according to the application.

Mode	Description	Default value			
		Pressure sensor input	TC input	RTD input	Voltage/current input
Engineering mode	Event 1 hold action	0 (Without hold action)			
	Event 2 hold action				
	Event 3 hold action				
	Event 4 hold action				
	Event 1 differential gap	2.0 MPa	2.0 °C [°F]	0.2 % of input span	
	Event 2 differential gap				
	Event 3 differential gap				
Event 4 differential gap					
Parameter setting mode	Event 1 set value	50			
	Event 1 set value				
	Event 1 set value				
	Event 1 set value				
	Control loop break alarm1 (LBA1) time (Event 3 only)	480 seconds			
	Control loop break alarm2 (LBA2) time (Event 4 only)	480 seconds			
	LBA1 deadband (Event 3 only)	0.0			
LBA2 deadband (Event 4 only)	0.0				

When any one of the following parameters' settings are changed,

- Transmission Output 1 Type Selection (Ao1)
- Transmission Output 2 Type Selection (Ao2)
- Transmission Output 3 Type Selection (Ao3)

all parameter settings shown in the table below will be changed to Factory Default Values according to the new setting. They must be changed according to the application.

Mode	Description	Default value			
		Pressure sensor input	TC input	RTD input	Voltage/current input
Engineering mode	Transmission output 1 scale high	Measured value (PV) and Set value (SV): Input scale high Manipulated output value (MV): 100.0 Deviation: +Input span			
	Transmission output 2 scale high				
	Transmission output 3 scale high				
	Transmission output 1 scale low	Measured value (PV) and Set value (SV): Input scale low Manipulated output value (MV): 0.0 Deviation: -Input span			
	Transmission output 2 scale low				
	Transmission output 3 scale low				

When any one of the following parameters' settings are changed,

- **Input 1_Decimal Point Position (1.PGdP)**
- **Input 2_Decimal Point Position (2.PGdP)**

all parameter settings shown in the table below will be automatically converted into the a values to match the new decimal point position as long as the converted values are in the acceptable range of each parameter. They must be check and changed if necessary according to the application

Mode	Description
Engineering mode	Input scale high
	Input scale low
	Input error determination point (high)
	Input error determination point (low)
	Transmission output 1 scale high
	Transmission output 2 scale high
	Transmission output 3 scale high
	Transmission output 1 scale low
	Transmission output 2 scale low
	Transmission output 3 scale low
	Event 1 hold action
	Event 2 hold action
	Event 3 hold action
	Event 4 hold action
	ON/OFF action differential gap (upper)
	ON/OFF action differential gap (lower)
	Setting limiter high
	Setting limiter low
Setup setting mode	PV bias
Parameter setting mode	Event 1 set value
	Event 2 set value
	Event 3 set value
	Event 4 set value
	LBA deadband
	Proportional band
	Setting change rate limiter (up)
	Setting change rate limiter (down)
SV setting & Monitor mode	Set value (SV)

Continued on the next page.

Continued from the previous page.

Precaution and Example of automatic conversion

- Decimal point position moves in accordance with the setting change.

Example: When the setting of the decimal point position is changed from 0 (no decimal place) to 1 (the first decimal place) with Input scale high (1.PGSH) set to 250 MPa:

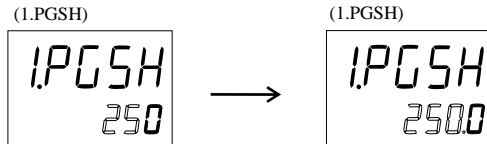

The display will change from 250 to 250.0.

- The displayed range of the controller is between -19999 and $+99999$ regardless of the decimal point position.

Example: When RTD input is selected for Input 2, and Input Scale Low (2.PGSL) is -200 °C, the decimal point position is changed from 0 to 2:

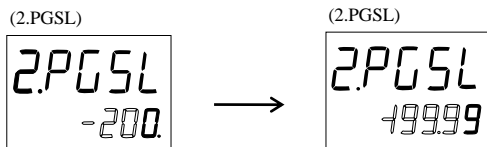

(Input scale low becomes -199.99 , because -200.00 is out of the display range.)

- When a number of decimal place for the set value is reduced due to the decimal point change, the set value is rounded off to the first decimal place and will be displayed without any decimal place.

Example: When the decimal point position is changed from 2 (two decimal places) to 0 (no decimal place) and Input scale high (1.PGSH) is 85.99:

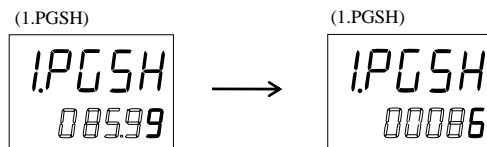

(The figure is rounded off to the first decimal place, and the Input Scale High 1.PGSH becomes 86.)



In the above example, if the decimal point position is changed back to 2 from 0, “1.PGSH” becomes 86.00.

8.4 Screen Configuration (F10)

■ STOP display selection (SPCH)

STOP message for control STOP mode can be displayed either on the upper display or the lower display. SPCH is to select the display to show the STOP message.

Data range: 0: Displays on the Measured value (PV1/PV2) unit (TYPE 1)
1: Displays on the Set value (SV) unit (TYPE 2)

Factory set value: 0



There are three different characters for STOP mode depending on how to be transferred from RUN to STOP.

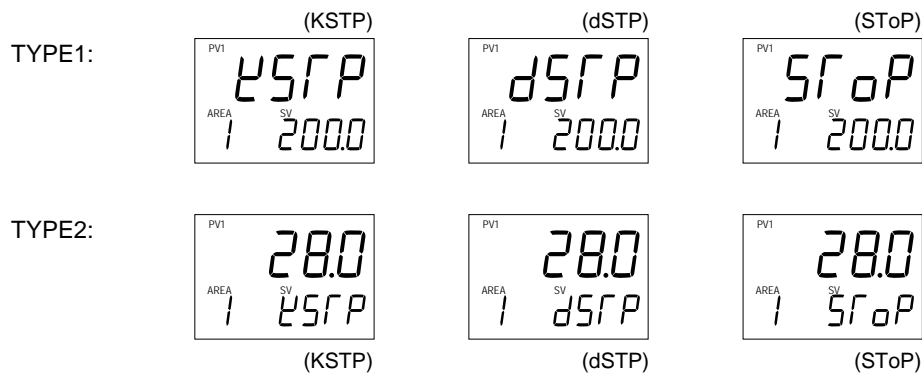

Display explanations:

		RUN/STOP with Event input	
		RUN (Contact closed)	STOP (Contact open)
RUN/STOP with key operation	RUN	RUN	STOP
	STOP	STOP is not displayed	d57P (dSTP)
		257P (KSTP)	57oP (SToP)

■ Bar graph display selection (dE)

Use to select the contents of the bar graph display.

Data range: 0: No display
1: Input 1_manipulated output value (MV)
2: Input 1_measured value (PV)
3: Input 1_set value (SV)
4: Input 1_deviation value
5: Unused (Not available)
6: Input 2_manipulated output value (MV)
7: Input 2_measured value (PV)
8: Input 2_set value (SV)
9: Input 2_deviation value

Factory set value: 0





Related parameters: Bar graph resolution setting (P. 64)

Continued on the next page.

Continued from the previous page.

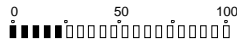

Bar graph display explanation:

<p>Manipulated output value (MV) display</p>	<p>Displays the Manipulated output value (MV). When Manipulated output value (MV) is at 0 % or less, the left-end dot of the bar-graph flashes. When MV exceeds 100 %, the right-end dot flashes.</p> <p>[Display example] </p>
<p>Measured value (PV) display</p>	<p>Scaling is available within the input range.</p> <p>[Display example] </p>
<p>Set value (SV) display</p>	<p>Displays the Set value (SV). Scaling is available within the input range.</p> <p>[Display example] </p>
<p>Deviation value display</p>	<p>Displays the deviation between the Measured value (PV) and the Set value (SV). When the Deviation display is selected, the dots at both ends of bar-graph light. A display resolution per dot is settable from 1 to 100.</p> <p>[Display example] </p>

The number of dot points: 10 dots (HA430) 20 dots (HA930)

■ Bar graph resolution setting (dEUT)

Use to set the bar graph display resolution for the deviation display. Set several digits per 1 dot of the bar graph.

Data range: 1 to 100 digit/dot

Factory set value: 100

Related parameters: Bar graph display selection (P. 63)

■ Decimal point position of MV scaling (MVdP)

Use to select the decimal point position of the MV scaling function.

- Data range:
- 0: No decimal place
 - 1: One decimal place
 - 2: Two decimal places
 - 3: Three decimal places
 - 4: Four decimal places

Factory set value: 1

Related parameters: MV scaling high (P. 64), MV scaling low (P. 65)

MV scaling function: The MV scaling function is used to make scaling of Manipulated output value 1 (MV1) from 0 to 100 % between the high and low MV scaling limits as the RPM of extruder's main motor.

■ MV scaling high (MVHS)

This value is to set the high limit value of MV scaling monitor value. Set the motor RPM when MV1 = 100 %.

Data range: -1999.9 to +9999.9

Factory set value: 100.0

Related parameters: Decimal point position of MV scaling (P. 64), MV scaling low (P. 65)



MV scaling monitor value is displayed on the SV of PV1/SV1 monitor screen (P. 102).

■ MV scaling low (MVLS)

This value is to set the low limit value of MV scaling monitor value. Set the motor RPM when MV1 = 0 %.

Data range: -1999.9 to +9999.9

Factory set value: 0.0

Related parameters: Decimal point position of MV scaling (P. 64), MV scaling high (P. 64)



MV scaling monitor value is displayed on the SV of PV1/SV1 monitor screen (P. 102).

[Example] If the motor RPM is set to 80.0 rpm when MV1 = 100 %.

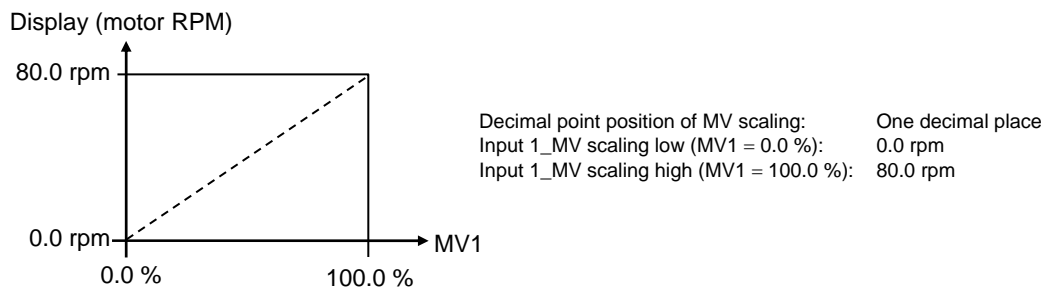

8.5 Direct Key (F11)

■ Auto/Manual transfer key operation selection (Fn1)

Use to select Use/Unuse of Auto/Manual transfer key (A/M).

Data range: 0: Unused
1: Auto/Manual transfer for Input 1
2: Auto/Manual transfer for Input 2
3: Common Auto/Manual transfer for Input 1 and Input 2

Factory set value: 3

■ Remote/Local transfer key operation selection (Fn2)

Use to select Use/Unuse of Remote/Local transfer key (R/L).

Data range: 0: Unused
1: Remote/Local transfer

Factory set value: 1

■ RUN/STOP transfer key operation selection (Fn3)

Use to select Use/Unuse of RUN/STOP transfer key (R/S).

Data range: 0: Unused
1: RUN/STOP transfer

Factory set value: 1

8.6 Input 1 (F21) Input 2 (F22)

■ Input type selection (1. InP, 2. InP)

Data range:

Input 1_input type selection (1. InP): 14 to 29 (22, 23: Not available)

[Input Range Table]

Set value	Input type		Input range	Hardware	
19	Voltage (Low) input	0 to 1 V	Programmable range (-19999 to +99999)	Voltage (Low) input group	
20		0 to 100 mV			
21		0 to 10 mV			
24		±100 mV			
25		±10 mV			
14	Current input	0 to 20 mA			
15		4 to 20 mA			
16	Voltage (High) input	0 to 10 V			Voltage (High) input group
17		0 to 5 V			
18		1 to 5 V			
26		±10 V			
27		±5 V			
28		±1 V			
29	Pressure sensor input	Resin Pressure Sensor		0.0 to 250.0 MPa	Pressure group
22	Unused (Not available)				
23	Unused (Not available)				

Input 2_input type selection (2. InP): 0 to 28 (22, 23: Not available)

[Input Range Table]

Set value	Input type		Input range	Hardware	
0	TC input	K	-200 to +1372 °C or -328.0 to +2501.6 °F	Voltage (Low) input group	
1		J	-200 to +1200 °C or -328.0 to +2192.0 °F		
2		R	-50 to +1768 °C or -58.0 to +3214.4 °F		
3		S	-50 to +1768 °C or -58.0 to +3214.4 °F		
4		B	0 to 1800 °C or 32.0 to 3272.0 °F		
5		E	-200 to +1000 °C or -328.0 to +1832.0 °F		
6		N	0 to 1300 °C or 32.0 to 2372.0 °F		
7		T	-200 to +400 °C or -328.0 to +752.0 °F		
8		W5Re/W26Re	0 to 2300 °C or 32.0 to 4172.0 °F		
9		PLII	0 to 1390 °C or 32.0 to 2534.0 °F		
12	RTD input	3-wire system Pt100	-200 to +850 °C or -328.0 to +1562.0 °F		
13		3-wire system JPt100	-200 to +600 °C or -328.0 to +1112.0 °F		
22	Unused (Not available)				
23	Unused (Not available)				
19	Voltage (Low) input	0 to 1 V	Programmable range (-19999 to +99999)	Voltage (Low) input group	
20		0 to 100 mV			
21		0 to 10 mV			
24		±100 mV			
25		±10 mV			
14	Current input	0 to 20 mA			
15		4 to 20 mA			
16	Voltage (High) input	0 to 10 V			Voltage (High) input group
17		0 to 5 V			
18		1 to 5 V			
26		±10 V			
27		±5 V			
28		±1 V			

Continued on the next page.

Continued from the previous page.



An input type change may only be made within the hardware groups as shown above.



Do not set to any number (including 10 and 11) and Input 1 range number (22 or 23) which is not described in the input range table above. This may cause malfunctioning.



Refer to the above input range table to select input type of the Remote input. Input range 0 to 13, 22 or 23 cannot be selected for the Remote input.

Factory set value: Input 1_input type selection (1. InP): Based on model code.

(When not specifying: Pressure sensor input)

Input 2_input type selection (2. InP): Based on model code. (When not specifying: Type K)

Related parameters: Display unit selection (P. 67), Decimal point position (P. 69), Input scale high (P. 69),
Input scale low (P. 70)

■ Display unit selection (1. UnIT, 2. UnIT)

These are the units of display for Input 1 and Input 2.

Data range: Input 1_display unit selection (1. UnIT): 2: MPa 3: bar 4: kgf/cm² 5: psi
Input 2_display unit selection (2. UnIT): 0: °C 1: °F

Factory set value: Input 1_display unit selection (1. UnIT): Pressure sensor input: 2
Voltage (V)/Current (I) inputs: 0

Input 2_display unit selection (2. UnIT): 0



The display unit selection becomes invalid when the Voltage/Current input is selected as input type.

■ Gain setting (GAIN) [F21]

Use to set the gain of the pressure sensor.

Data range: 0.500 to 4.000 mV/V

Factory set value: CZ-100P, CZ-200P: 1.500 mV/V

Setting procedure:

● CZ-100P, CZ-200P:

Set the rated output value (mV/V) engraved on the rated nameplate attached to the pressure sensor housing.

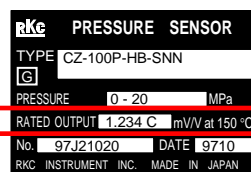

Rated output value 1.234 mV/V

(Example of the rated nameplate)



The rated output value (mV/V) of the CZ-100P/CZ-200P is when the cable is at a length of 5 m. If the cable is extended, correct the rated output value using the following equation. Set the correction value thus calculated to “Gain setting (GAIN).”

$$\text{Correction equation: } e1 = e2 (1 + K \cdot L) \longrightarrow e2 = \frac{e1}{1 + K \cdot L}$$

e1: Rated output in standard-cable length 5 m (mV/V is described on the nameplate of the sensor)

e2: Rated output after extension

K: Correction factor* $1.96 \times 10^{-4}/\text{m}$ [Non-explosionproof specification type],
 $1.40 \times 10^{-4}/\text{m}$ [Explosionproof specification type]

* When using $0.5 \text{ mm}^2 \times 4\text{-core}$ shielded cable (standard-cable) or equal.

L: Extended cable length (m)

● The strain gauge type sensor other than RKC product:

Set the rated output value (mV/V). The rated output value depends on the sensors, refer to the instruction manual for each sensor being used.

■ **Linearize type selection (LInS) [F21]**

Use to select the linearizing type of our pressure sensor CZ-100P/CZ-200P.

Data range: 0: Unused
 1 to 20: Used

[Linearizing type selection table]

Set value	Linearizing type symbol	Set value	Linearizing type symbol	Set value	Linearizing type symbol
0	No symbol	7	J	14	S
1	C	8	K	15	T
2	D	9	L	16	U
3	E	10	M	17	V
4	F	11	P	18	W
5	G	12	Q	19	X
6	H	13	R	20	Y

Factory set value: 0

Setting procedure: Select the linearizing type symbol engraved on the rated nameplate attached to the CZ-100P or CZ-200P housing.

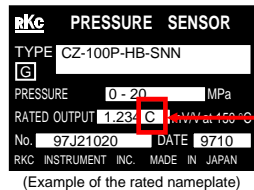

The symbol described at the end of the rated output value denotes the linearizing type. In the example at the left, “C” is the symbol of denoting the linearizing type.



This setting does not used to the strain gauge type sensors other than RKC product. Set it to “0” fixed.

■ **Shunt resistance output value (SHnT) [F21]**

When the strain gauge type sensor other than RKC product is used, it is set “What percentage of the rated output” is output when the full scale point of the Input 1_measured value (PV1) is adjusted by Auto calibration.

Data range: 40.0 to 100.0 %

Factory set value: 80.0



For details of the shunt resistance output value, refer to Instruction Manual for each sensor being used.

■ Decimal point position (1. PGdP, 2. PGdP)

Use to select the decimal point position of the input range.

Data range: 0: No decimal place 3: Three decimal places
 1: One decimal place 4: Four decimal places
 2: Two decimal places

Input 1_decimal point position (1. PGdP):

Pressure sensor input: Less than 1 MPa (Rated pressure): 0 to 4
 Less than 10 MPa (Rated pressure): 0 to 3
 Less than 100 MPa (Rated pressure): 0 to 2
 100 MPa or more (Rated pressure): 0 or 1

Voltage (V)/Current (I) inputs: 0 to 4

Input 2_decimal point position (2. PGdP):

TC input: 0 or 1

RTD input: 0 to 2

Voltage (V)/Current (I) inputs: 0 to 4

Factory set value: Input 1_decimal point position (1. PGdP): 1

 Input 2_decimal point position (2. PGdP): 1

Related parameters: Input type selection (P. 66), Input scale high (P. 69), Input scale low (P. 70)

■ Input scale high (1. PGSH, 2. PGSH)

This value is high limit of the input scale range.

Data range: Pressure sensor input: Input scale low to Maximum value of the selected input range
 TC/RTD inputs: Input scale low to Maximum value of the selected input range
 Voltage (V)/Current (I) inputs:
 -19999 to +99999
 (Varies with the setting of the decimal point position)

Factory set value: Input 1_input scale high (1.PGSH):

 Pressure sensor input: 50.0

 Voltage (V)/Current (I) inputs: 100.0

 Input 2_input scale high (2.PGSH):

 TC/RTD inputs: Maximum value of the selected input range

 Voltage (V)/Current (I) inputs: 100.0

Related parameters: Input type selection (P. 66), Decimal point position (P. 69), Input scale low (P. 70)

Input Scale High function:

The input scale range can be easily set by setting the input scale high limit/low limit.



When a Voltage/Current input type is selected, the input scale high limit can be set lower than the input scale low limit. (Input scale high limit < Input scale low limit)

■ Input scale low (1. PGSL, 2. PGSL)

This value is to set the low limit of the input scale range.

Data range: Pressure sensor input: Minimum value of the selected input range to Input scale high
 TC/RTD inputs: Minimum value of the selected input range to Input scale high
 Voltage (V)/Current (I) inputs: -19999 to +99999
 (Varies with the setting of the decimal point position)

Factory set value: Input 1_input scale low (1.PGSL):
 Pressure sensor input: 0.0
 Voltage (V)/Current (I) inputs: 0.0
 Input 2_input scale low (2.PGSL):
 TC/RTD inputs: Minimum value of the selected input range
 Voltage (V)/Current (I) inputs: 0.0

Related parameters: Input type selection (P. 66), Decimal point position (P. 69), Input scale high (P. 67)

Input Scale Low function:

The input scale range can be easily set by setting the Input scale high/low.



When a Voltage/Current input type is selected, the Input scale high can be set lower than the Input scale low. (Input scale high < Input scale low)

■ Input error determination point (high) (1. PoV, 2. PoV)

Use to set Input error determination point (high). Input error determination function is activated when a measured value reaches the limit, and control output value selected by Action at input error will be output.

Data range: Input scale low – (5 % of input span) to Input scale high + (5 % of input span)

Factory set value: Input 1_input error determination point (high) (1. PoV):
 Pressure sensor input: Input scale high + (5 % of input span)
 Voltage (V)/Current (I) inputs: 105.0
 Input 2_input error determination point (high) (2. PoV):
 TC/RTD inputs: Input scale high + (5 % of input span)
 Voltage (V)/Current (I) inputs: 105.0

Related parameters: Input error determination point (low) (P. 71), Action at input error (high) (P. 89),
 Action at input error (low) (P. 89), Manipulated output value at input error (P. 90)

■ Input error determination point (low) (1. PUn, 2. PUn)

Use to set Input error determination point (low). Input error determination function is activated when a measured value reaches the limit, and control output value selected by Action at input error will be output.

Data range: Input scale low – (5 % of input span) to Input scale high + (5 % of input span)

Factory set value: Input 1_input error determination point (low) (1. PUn):

Pressure sensor input: Input scale low – (5 % of input span)

Voltage (V)/Current (I) inputs: –5.0

Input 2_input error determination point (low) (1. PUn):

TC/RTD inputs: Input scale low – (5 % of input span)

Voltage (V)/Current (I) inputs: –5.0

Related parameters: Input error determination point (high) (P. 70), Action at input error (high) (P. 89),
Action at input error (low) (P. 89), Manipulated output value at input error (P. 90)



[Example] When the input scale is 0.0 to 250.0:

Input span: 250.0, 5 % of input span: 12.5, Setting range: –12.5 to +262.5

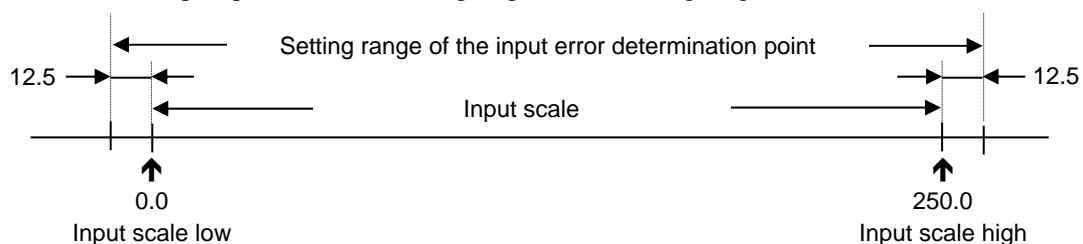

■ Burnout direction (1. boS, 2. boS)

Use to select Burnout direction in input break. When input break is detected by the controller, the measured value go either Upscale or Downscale according to the Burnout direction setting.

Data range: Pressure sensor input [Input 1]: 0 (Upscale), 1 (Downscale)

TC input [Input 2]: 0 (Upscale), 1 (Downscale)

RTD input [Input 2]: 0 (Upscale)

Voltage (low) input [Input 1, Input 2]: 0 (Upscale), 1 (Downscale)

Voltage (high) input [Input 1, Input 2]: 1 (Downscale)

Current (I) input [Input 1, Input 2]: 1 (Downscale)

Factory set value: Input 1_burnout direction (1. boS): 0 (Upscale)

Input 2_burnout direction (2. boS): 0 (Upscale)



For the following types of input, the action when an input break occurs is fixed, regardless of the Burnout direction setting.

- RTD input: Upscale
- Voltage (high) input: Downscale (Indicates value near 0 V.)
- Current (I) input: Downscale (Indicates value near 0 mA.)

■ Square root extraction selection (1. SQr, 2. SQr)

Use to select Use/Unuse of the Square root extraction for the measured value.

Data range: 0: Unused
 1: Used

Factory set value: Input 1_square root extraction selection (1. SQr): 0
 Input 2_square root extraction selection (2. SQr): 0

Related parameters: PV low input cut-off (P. 45)

Square Root Extraction function:

The controller can receive the input signal directly from a differential pressure type flow transmitter by using Square root extraction function without using a square root extractor.

■ PV hold function (1. HLdS, 2. HLdS)

Use to select Use/Unuse of the peak hold/bottom hold function for a Measured value (PV).

Data range: 0: Unused
 1: Used

Factory set value: Input 1_PV1 hold function (1. HLdS): 0
 Input 2_PV2 hold function (2. HLdS): 0

Related parameters: PV1 peak hold value monitor (P. 103), PV1 bottom hold value monitor (P. 104),
 PV1 hold reset (P. 105), PV2 peak hold value monitor (P. 105),
 PV2 bottom hold value monitor (P. 105), PV2 hold reset (P. 105)

■ Power supply frequency selection (PFrQ)

Use to select the power supply frequency of the controller suited to the application.

Data range: 0: 50 Hz
 1: 60 Hz

Factory set value: 0

8.7 Event Input (F23)

■ Event input logic selection (dISL)

Use to assign the function (memory area, operation mode) for the Event inputs (DI 1 to DI 5).

Data range: 0 to 15 (Refer to the following table)

[Function Assignment Table]

Set value	DI 1	DI 2	DI 3	DI 4	DI 5
	Terminal No. 30-31	Terminal No. 30-32	Terminal No. 30-33	Terminal No. 30-34	Terminal No. 35-36
0	Unused (No function assignment)				
1	Memory area number selection (1 to 16)				Memory area set
2	Memory area number selection (1 to 16)				Memory area set
3	Memory area number selection (1 to 16)				Memory area set
4	Memory area number selection (1 to 8)			Memory area set	RUN/STOP transfer
5	Memory area number selection (1 to 8)			Memory area set	Remote/Local transfer
6	Memory area number selection (1 to 8)			Memory area set	Auto/Manual transfer
7	Memory area number selection (1 to 8)			Memory area set	Hold reset
8	Memory area number selection (1 to 8)			Memory area set	Interlock release
9	Memory area number selection (1 to 4)		Memory area set	RUN/STOP transfer	Auto/Manual transfer
10	Memory area number selection (1 to 4)		Memory area set	RUN/STOP transfer	Remote/Local transfer
11	Memory area number selection (1 to 4)		Memory area set	Remote/Local transfer	Auto/Manual transfer
12	Memory area number selection (1 to 4)		Memory area set	Hold reset	Interlock release
13	Auto/Manual transfer	RUN/STOP transfer	Remote/Local transfer	Hold reset	Interlock release
14	Auto/Manual transfer	Input 1_ manual output down (motor RPM down)	Input 1_ manual output up (motor RPM up)	Input 1_ manual output 0 % reset (motor RPM reset)	RUN/STOP transfer
15	Auto/Manual transfer	Input 2_ manual output down (motor RPM down)	Input 2_ manual output up (motor RPM up)	Input 2_ manual output 0 % reset (motor RPM reset)	RUN/STOP transfer



Event input terminals:

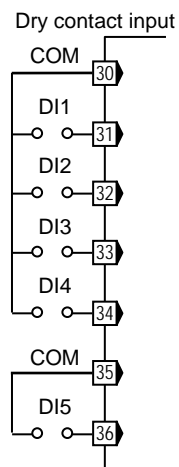

Contact input from external devices or equipment should be dry contact input. If it is not dry contact input, the input should have meet the specifications below.

Contact specifications: At OFF (contact open) 500 k Ω or more
At ON (contact closed) 10 Ω or less

Factory set value: 1

Event Input function: Refer to the next page.

Continued on the next page.

Continued from the previous page.

● **Contact status of memory area number selection**



To store a new Memory area number as the Control area, close the DI for Memory area set.

Event input	Memory area number															
	1	2	3	4	5	6	7	8	9	10	11	12	13	14	15	16
DI 1	x	-	x	-	x	-	x	-	x	-	x	-	x	-	x	-
DI 2	x	x	-	-	x	x	-	-	x	x	-	-	x	x	-	-
DI 3	x	x	x	x	-	-	-	-	x	x	x	x	-	-	-	-
DI 4	x	x	x	x	x	x	x	x	-	-	-	-	-	-	-	-

x: Contact open -: Contact closed

Transfer timing of memory area number:

[Example] Change the memory area number to 6
(when “4” is selected in “Event input logic selection”)

First, close the contacts between DI1 and DI3 and the common terminal. Next, open the contact between DI2 and the common. Then, close the contact between DI4 and the common from open status, the memory area in the controller will change to “6”.

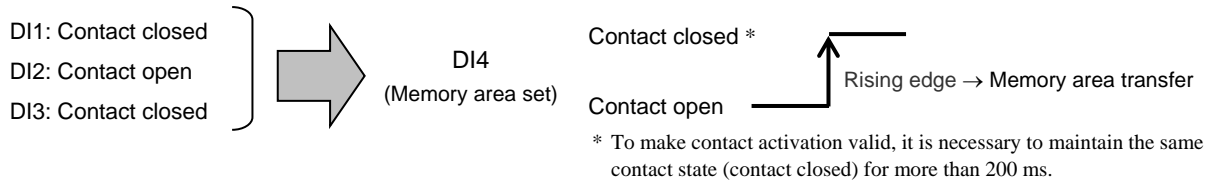

● **Relationship between contact state and each operation state**

	Contact closed	Contact open	No event input or not selected
RUN/STOP transfer	RUN (Control RUN)	STOP (Control STOP)	RUN (Control RUN)
Auto/Manual transfer	Auto	Manual	Auto
Remote/Local transfer	Remote or cascade control	Local	Local
Hold reset	Hold reset execution	—	By key operation
Interlock release	Interlock release execution	—	
Manual output down (Motor RPM down) ¹	Manual output down (Motor RPM down)	—	
Manual output up (Motor RPM up) ²	Manual output up (Motor RPM up)	—	—
Manual output 0 % reset (Motor RPM reset) ³	Manual output 0 % reset (Motor RPM reset)	—	

¹ Decreases manipulated output value (motor RPM) under Manual control with contacts closed. (It takes about 25 seconds to 1000 digits.)

² Increases manipulated output value (motor RPM) under Manual control with contacts closed. (It takes about 25 seconds to 1000 digits.)

³ The manipulated output value (motor RPM) is reset to 0 % based on the edge discrimination of “open” to “closed.”

In addition, switched to “Manual Control” regardless of Auto/Manual transfer setting.

Continued on the next page.

Continued from the previous page.

● **RUN/STOP transfer**

Mode select from front key or communication	Status of event input (DI)	Actual operation mode	STOP display
RUN (Control RUN)	Contact closed	RUN (Control RUN)	STOP is not displayed
	Contact open	STOP (Control STOP)	<i>STOP</i>
STOP (Control STOP)	Contact closed		<i>STOP</i>
	Contact open		<i>STOP</i>

● **Auto/Manual transfer**

Mode select from front key or communication	Status of event input (DI)	Actual operation mode	Display lamp
Auto	Contact closed	Auto	MAN mode lamp ON
	Contact open	Manual	MAN mode lamp OFF
Manual	Contact closed		
	Contact open		

● **Remote/Local transfer**

Mode select from front key or communication	Status of event input (DI)	Actual operation mode	Display lamp
Remote	Contact closed	Remote	REM mode lamp ON
	Contact open	Local	REM mode lamp OFF
Local	Contact closed		
	Contact open		

Transfer timing of RUN/STOP, Auto/Manual, and Remote/Local:

The selection operation is taken when DI contact is closed from the open condition (Rising edge).

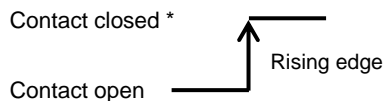

* To make contact activation valid, it is necessary to maintain the same contact state (contact closed) for more than 200 ms.

8.8 Output (F30)

■ Output logic selection (LoGC)

This is used to assign the output function (control output, event, etc.) for the output (OUT1 to OUT5).

Data range: 1 to 11 (Refer to the following table)

1, 2, 9 and 10: Unused (Not available)

[Output Assignment Table] (M: Relay contact output, V: Voltage pulse output, R: Current output, E: Voltage output, T: Triac output)

Set value	OUT1 (M/V/R/E/T)	OUT2 (M/V/R/E/T)	OUT3 (M/V/R/E/T)	OUT4 (M)	OUT5 (M)	Remarks
1	This set value is not used for the HA430/930.					—
2	This set value is not used for the HA430/930.					—
3	MV1	EV3 (Energized) or EV4 (Energized)	EV2 (Energized)	EV1 (Energized)	FAIL (De-energized)	Energized alarm corresponding to FAIL output
4	MV1	EV3 (De-energized) or EV4 (De-energized)	EV2 (De-energized)	EV1 (De-energized)	FAIL (De-energized)	De-energized alarm corresponding to FAIL output
5	MV1	MV2	EV4 (Energized)	EV3 (Energized)	EV1 (Energized) or EV2 (Energized)	Energized alarm corresponding to two loops control
6	MV1	MV2	EV4 (De-energized)	EV3 (De-energized)	EV1 (De-energized) or EV2 (De-energized)	De-energized alarm corresponding to two loops control
7	MV1	MV2	EV3 (Energized) or EV4 (Energized)	EV2 (Energized)	EV1 (Energized)	Energized alarm corresponding to two loops control
8	MV1	MV2	EV3 (De-energized) or EV4 (De-energized)	EV2 (De-energized)	EV1 (De-energized)	De-energized alarm corresponding to two loops control
9	This set value is not used for the HA430/930.					—
10	This set value is not used for the HA430/930.					—
11	MV1	EV4 (Energized)	EV 3 (Energized)	EV 2 (Energized)	EV 1 (Energized)	Energized alarm

MV 1 = Manipulated output value of Input 1, MV 2 = Manipulated output value of Input 2,

EV 1 = Output of Event 1, EV 2 = Output of Event 2, EV 3 = Output of Event 3, EV 4 = Output of Event 4, FAIL = FAIL output



An output logic becomes *OR* output when two or more output functions are assigned to one output.



When three transmission outputs are selected, the transmission outputs are automatically assigned to OUT1 through OUT3 and it has priority over the Output logic selection (LoGC). To select Manipulated output value of Input 1 or Input 2 as output type of OUT1, OUT2 or OUT3, select “1. MV: Input 1_manipulated output value (MV)” or “2. MV: Input 2_manipulated output value (MV)” at the parameters of Transmission output type selection.



The OUT3 output terminals (No. 7 and 8) are used when any sensor power supply is specified. The use of this function disables the use of OUT3 to OUT5 as control output, event output and transmission output. In addition, the number of transmission output points becomes 2 maximum.

Factory set value: For 1-input controller: 3
For 2-input controller: 5

Related parameters: Output timer setting (P. 77), Alarm lamp lighting condition setting (P. 77),
Event type selection (P. 80), Transmission output type selection (P. 79)

■ Output timer setting (oTT1 to oTT5)

Output timer setting is to set an output delay time for event outputs.

Data range: 0.0 to 600.0 seconds

Factory set value: 0.0

Related parameters: Output logic selection (P. 76), Alarm lamp lighting condition setting (P. 77),
Event type selection (P. 80)

Output Timer Setting function:

When an event condition becomes ON status, the output is suppressed until the Output Timer set time elapses. After the time is up, if the event output is still ON status, the output will be produced.

Example: When set the event timer to 100.0 seconds.

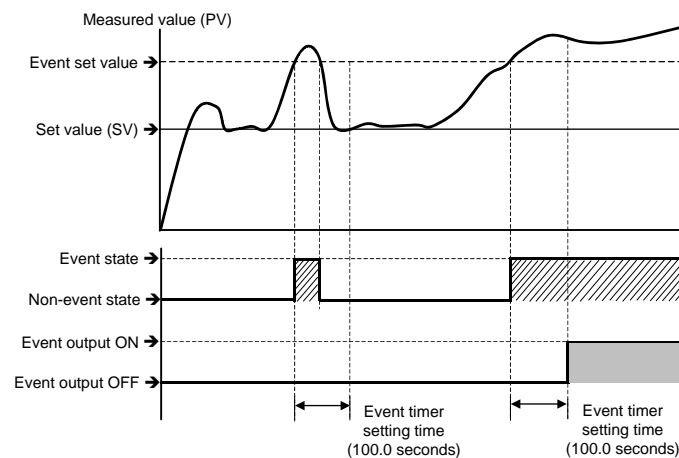

■ Alarm lamp lighting condition setting (ALC1, ALC2)

Use to set an alarm (ALM) lamp lighting conditions to Event 1 to Event 4.

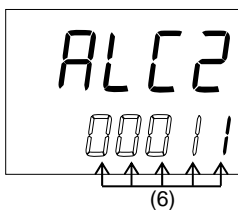
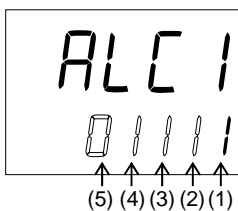

Data range:

[ALC1 screen]

(1) Event 1

0: ALM lamp is not lit 1: ALM lamp is lit

(2) Event 2

0: ALM lamp is not lit 1: ALM lamp is lit

(3) Event 3

0: ALM lamp is not lit 1: ALM lamp is lit

(4) Event 4

0: ALM lamp is not lit 1: ALM lamp is lit

(5) "0" fixed (No setting)

Factory set value: Event 1 to Event 4: 1 (ALM lamp is lit)

Related parameters: Output logic selection (P. 76), Output timer setting (P. 77),
Event type selection (P. 80)

[ALC2 screen]

(6) **As this screen is not used for the HA430/930, do not change the setting.**



The alarm lamp is lit through the OR operation of Event 1 to Event 4 each of which is set to "1: ALM lamp is lit."

■ Interlock function (oTIL)

Use to select the Interlock function to output 1 (OUT1) to output 5 (OUT5).

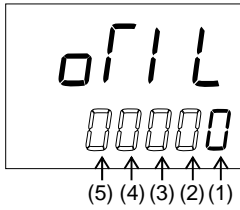

Data range:

- | | | | | | |
|---------------------|-----------|---------|---------------------|-----------|---------|
| (1) Output 1 (OUT1) | 0: Unused | 1: Used | (4) Output 4 (OUT4) | 0: Unused | 1: Used |
| (2) Output 2 (OUT2) | 0: Unused | 1: Used | (5) Output 5 (OUT5) | 0: Unused | 1: Used |
| (3) Output 3 (OUT3) | 0: Unused | 1: Used | | | |

Factory set value: 00000

Related parameters: Output logic selection (P. 76), Event type selection (P. 80), Interlock release (P. 106)

Interlock function:

The Interlock action holds the event state even if the measured value is out of the event zone after it enters the event zone once.

This interlock is released through key operation, Event input (optional), or Communication (optional).

[Example] Process high:

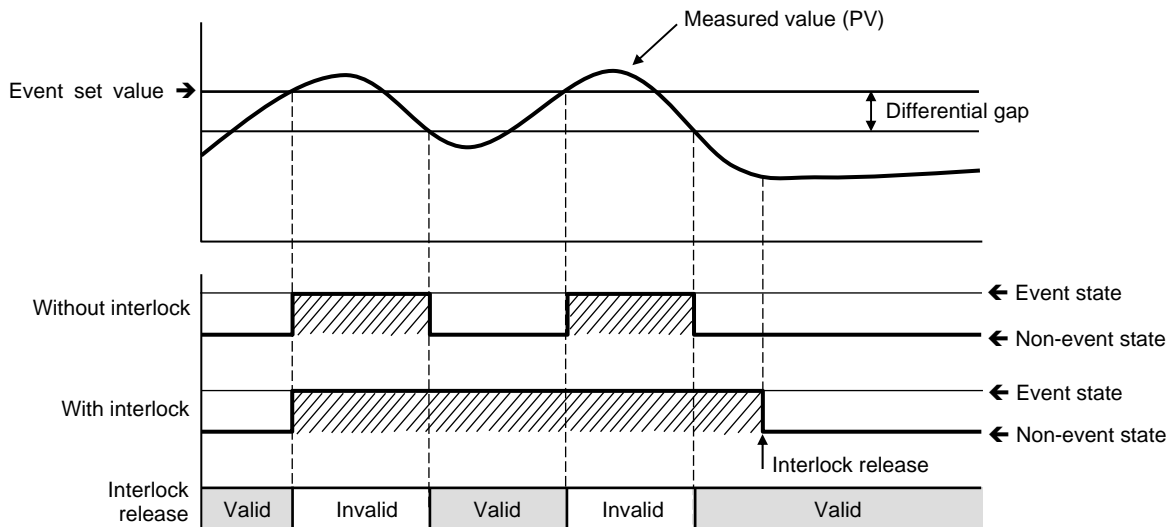

The Interlock function is released for any of the following.

- When the power is turn on. (However, the Interlock function becomes ON when set to the event state simultaneously with the control started.)
- When the control is stopped.



Burnout results in the event state and also activating the Interlock function.

8.9 Transmission Output 1 (F31) Transmission Output 2 (F32) Transmission Output 3 (F33)

■ Transmission output type selection (Ao1, Ao2, Ao3)

Use to select the transmission output type.

Data range:	-----: None	2.	P_H (2. PV): Input 2_measured value (PV)
	1. P_H (1. PV): Input 1_measured value (PV)	2.	S_H (2. SV): Input 2_set value (SV)
	1. S_H (1. SV): Input 1_set value (SV)	2.	dEV (2.dEV): Input 2_deviation value
	1. dEV (1.dEV): Input 1_deviation value	2.	\bar{H} (2. MV): Input 2_manipulated output value (MV)
	1. \bar{H} (1. MV): Input 1_manipulated output value (MV)		PoS (PoS): Unused (Not available)

Factory set value: ----- (None)

Related parameters: Transmission output scale high (P. 79), Transmission output scale low (P. 79)



Specify the output type of the transmission output when ordering.



When transmission outputs are selected and used, the outputs are allocated as follows.

- Transmission output 1: output 1 (OUT1)
- Transmission output 2: output 2 (OUT2)
- Transmission output 3: output 3 (OUT3)



The transmission has priority over the Output logic selection (LoGC).

■ Transmission output scale high (AHS1, AHS2, AHS3)

Use to set a scale high limit value of the transmission output.

Data range:	Measured value (PV) and Set value (SV):	Input scale low to Input scale high
	Manipulated output value (MV):	-5.0 to +105.0 %
	Deviation:	-Input span to +Input span
Factory set value:	Measured value (PV) and Set value (SV):	Input scale high
	Manipulated output value (MV):	100.0
	Deviation:	+Input span

Related parameters: Transmission output type selection (P. 79), Transmission output scale low (P. 79)

■ Transmission output scale low (ALS1, ALS2, ALS3)

Use to set a scale low limit value of the transmission output.

Data range:	Measured value (PV) and Set value (SV):	Input scale low to Input scale high
	Manipulated output value (MV):	-5.0 to +105.0 %
	Deviation:	-Input span to +Input span
Factory set value:	Measured value (PV) and Set value (SV):	Input scale low
	Manipulated output value (MV):	0.0
	Deviation:	-Input span

Related parameters: Transmission output type selection (P. 79), Transmission output scale high (P. 79)

8.10 Event 1 (F41) Event 3 (F43) Event 2 (F42) Event 4 (F44)

■ Event type selection (ES1, ES2, ES3, ES4)

Use to select a type of the event 1, 2, 3 and 4.

Data range:	0: None	5: Process high ¹
	1: Deviation high ¹	6: Process low ¹
	2: Deviation low ¹	7: SV high
	3: Deviation high/low ¹	8: SV low
	4: Band ¹	9: Control loop break alarm (LBA) ²

¹ Event hold action is available.

² "9: Control loop break alarm (LBA)" can be selected only for Event 3 and Event 4.

Factory set value: 0

Related parameters: Output logic selection (P. 76), Output timer setting (P. 77),
Alarm lamp lighting condition setting (P. 77), Event hold action (P. 82),
Event differential gap (P. 83), Event assignment (P. 84),
Event action at input error (P. 84), Event set value (P. 35),
Control loop break alarm (LBA) time (P. 35), LBA deadband (P. 36)

● Event action type

(▲: Set value (SV) Δ: Event set value : Event differential gap)

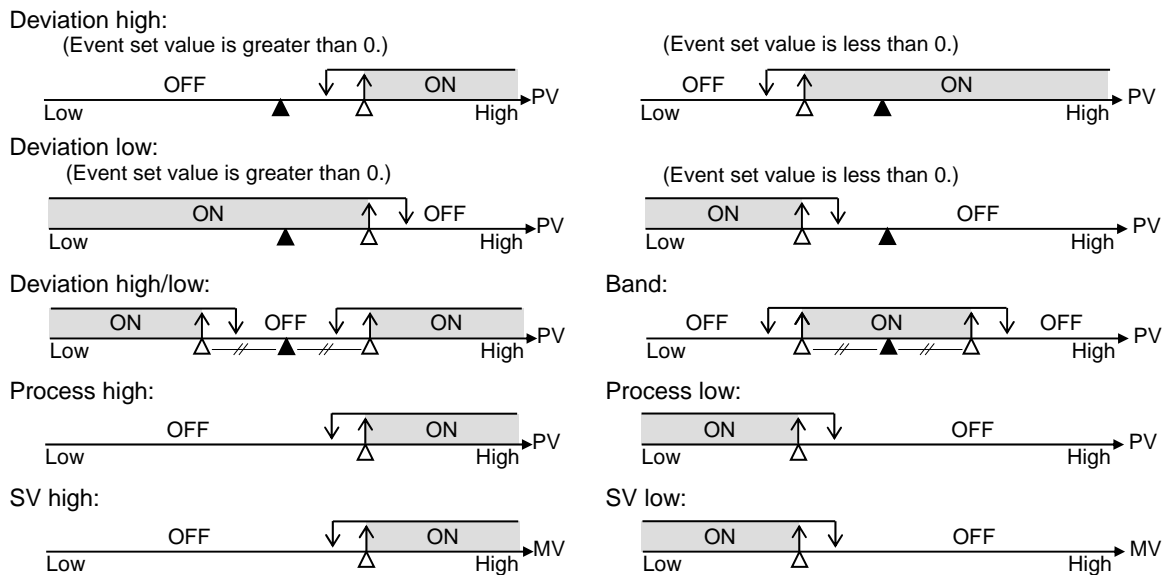

Continued on the next page.

Continued from the previous page.

● Control loop break alarm (LBA)

The Control loop break alarm (LBA) function is used to detect a load (heater) break or a failure in the external actuator (magnet relay, etc.), or a failure in the control loop caused by an input (sensor) break. The LBA function is activated when control output reaches 0 % (low limit with output limit function) or 100 % (high limit with output limit function). LBA monitors variation of the Measured value (PV) for the length of LBA time. When the LBA time has elapsed and the PV is still within the alarm determination range, the LBA will be ON.

The LBA function produces the alarm when any of the following conditions occurs.

LBA determination range: TC/RTD input: 2 °C [2 °F] (fixed)

Pressure sensor input and Voltage/Current input:
0.2 % of input span (fixed)

● When the control output reaches 0 % (low limit with output limit function)

For direct action: When the LBA time has passed and the PV has not risen beyond the alarm determination range, the alarm will be turned on.

For reverse action: When the LBA time has passed and the PV has not fallen below the alarm determination range, the alarm will be turned on.

● When the output exceeds 100 % (low limit with output high function)

For direct action: When the LBA time has passed and the PV has not fallen below the alarm determination range, the alarm will be turned on.

For reverse action: When the LBA time has passed and the PV has not risen beyond the alarm determination range, the alarm will be turned on.



If the Autotuning function is used, the LBA time is automatically set twice as large as the Integral time. The LBA setting time will not be changed even if the Integral time is changed.



LBA function is not operative when:

- AT function is activated.
- The controller is in STOP mode.
- LBA function is set to "OFF."
- LBA function is not assigned to Event (ES3) or Event 4 (ES4).



The LBA function does not detect a location which causes alarm status. If LBA alarm is ON, check each device or wiring of the control loop.



While the LBA is ON (under alarm status), the following conditions cancel the alarm status and LBA will be OFF:

- The Measured value (PV) rises beyond (or falls below) the LBA determination range within the LBA setting time.
- The Measured value (PV) enters within the LBA deadband.

■ **Event hold action (EHo1, EHo2, EHo3, EHo4)**

Use to set a event hold action for the Event 1, 2, 3 or 4.



When high alarm with Hold/Re-hold action is used for Event function, alarm does not turn on while Hold action is in operation. Use in combination with a high alarm without Hold action in order to prevent overheating which may occur by failure of control devices, such as welding of relays.

Data range: 0: OFF
 1: ON
 2: Re-hold action ON

Factory set value: 0

Related parameters: Event type selection (P. 80), Event differential gap (P. 83), Event assignment (P. 84),
 Event action at input error (P. 84), Event set value (P. 35)

● **Hold action**

When Hold action is ON, the event action is suppressed at start-up or STOP to RUN until the measured value has entered the non-event range.

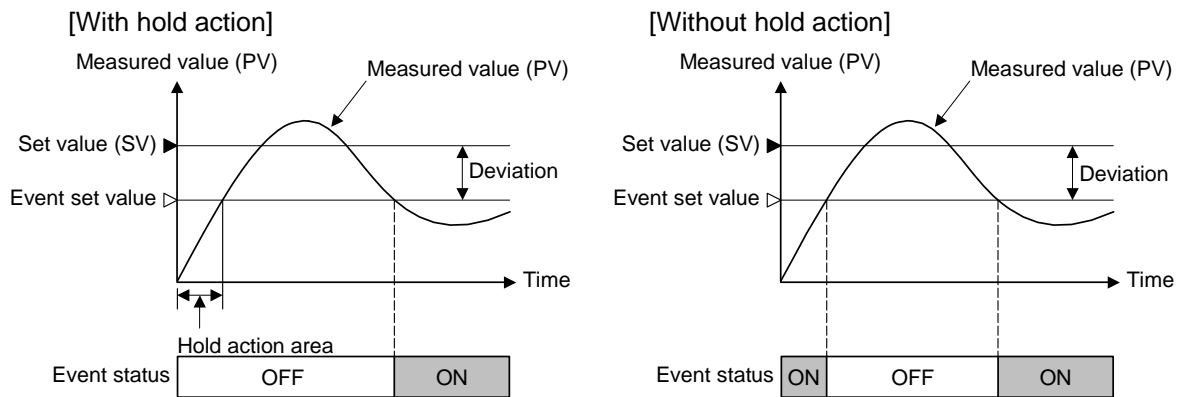

● **Re-hold action**

When Re-hold action is ON, the event action is also suppressed at the control set value change until the Measured value has entered the non-event range.

Action condition	1: Hold action ON (Only Hold action)	2: Re-hold action ON (Hold and Re-hold actions)
When the power is turned on	Hold action	Hold action
When transferred from STOP (control STOP) to RUN (control RUN)	Hold action	Hold action
When the Set value (SV) is changed	Without Hold and Re-hold actions	Re-hold action



The Re-hold action is invalid for any of the following. However, the Hold action is valid.

- When Setting change rate limiter other than “OFF (Unused)” are set
- When Remote/Local transfer is the remote mode

Continued on the next page.

Continued from the previous page.

[Example] When Event 1 type is the deviation low:

When Re-hold action is OFF and event output type is deviation, the event output is produced due to the Set value change. The Re-hold action suppresses the alarm output until the Measured value has entered the non-event range again.

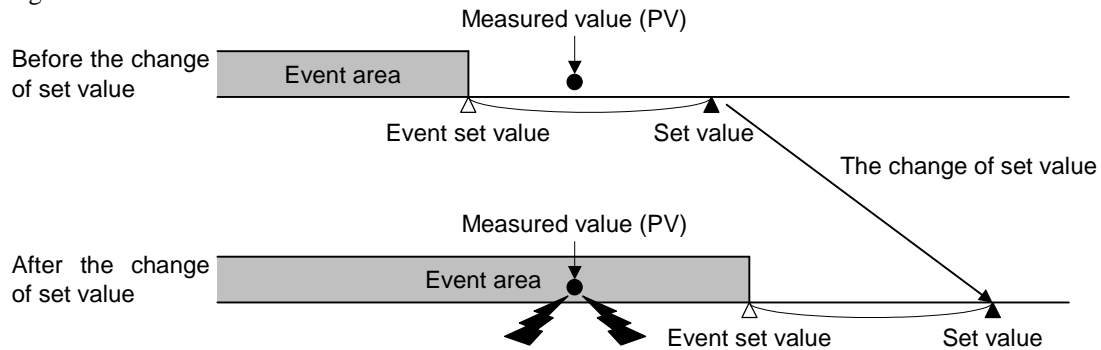

■ Event differential gap (EH1, EH2, EH3, EH4)

Use to set a differential gap of the Event 1, 2, 3 or 4.

Data range: 0 to Input span
(Varies with the setting of the Decimal point position)

Factory set value: Pressure sensor input [Input 1]: 2.0 MPa
TC/RTD inputs [Input 2]: 2.0 °C [°F]
Voltage (V)/Current (I) inputs [Input 1, Input 2]: 0.2 % of input span

Related parameters: Event type selection (P. 80), Event hold action (P. 82), Event assignment (P. 84),
Event action at input error (P. 84), Event set value (P. 35)

Event differential gap function:

It prevents chattering of event output due to the measured value fluctuation around the Event set value.

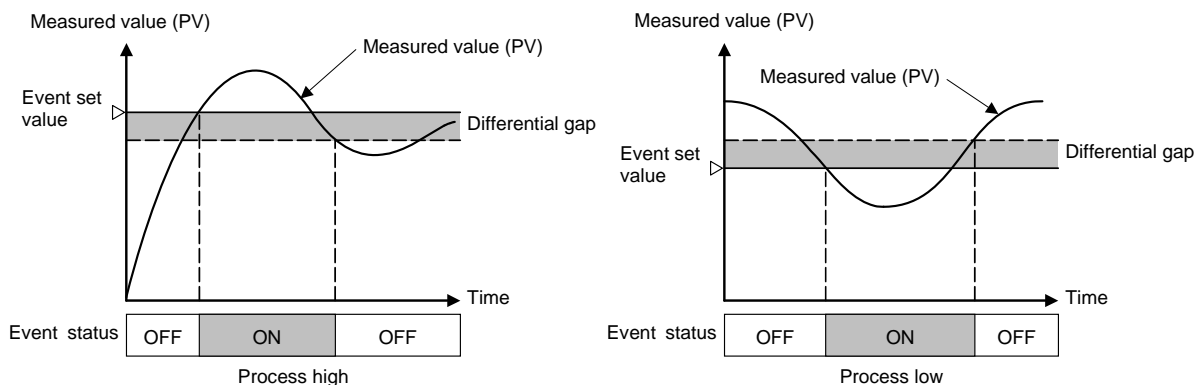

8.11 Control (F50)

■ Hot/Cold start selection (Pd)

Use to select the start mode at power recovery.

Data range: Refer to the following table

Set value	Power failure less than 3 seconds	Power failure 3 seconds or more
0	Hot start 1	Hot start 1
1	Hot start 1	Hot start 2
2	Hot start 1	Cold start
3	Hot start 2	Hot start 2
4	Hot start 2	Cold start
5	Cold start	Cold start
6	Hot start 1	Stop start
7	Hot start 2	Stop start
8	Stop start	Stop start

Factory set value: 5

Hot/Cold start function:

After the power failure, when power is back to the controller,

Hot start 1: the controller will return to the same operation mode and the same manipulated value which were used or calculated by the controller before power failure.

Hot start 2: the controller will return to the same operation mode which was used by the controller before power failure.

In the Manual mode, the output value will be at the low output limit value.

In the Auto mode, the controller will calculate the manipulated output value regardless that before power failure. So, the manipulated output varies.

Cold start: the controller will automatically go to Manual mode and output the low output limit value.

Stop start: Started in the control stop (STOP) state regardless of the RUN mode (Auto/Manual) before power failure. Set to the RUN mode before power failure when changed to RUN from STOP by RUN/STOP selection.

■ Input 2_use selection (CAM)

Use to select the usage of Input 2.

Data range: 0: Single loop control
1: Remote input

Factory set value: 0



The setting items “CAr” and “CAb” displayed hereafter are not used in the HA430/930.

■ **SV tracking (TrK)**

To select Use/Unuse of SV tracking.

Data range: 0: Unused
 1: Used

Factory set value: 1

SV Tracking function:

With SV Tracking function, when Remote/Local mode is transferred from Remote to Local, the set value used in Remote mode before the mode transfer will be kept using in Local mode to prevent rapid set value change.

Operation mode:	Local	→	Remote	→	Local
Set value used	Local set value		Remote set value		Local set value
SV tracking used	Local set value ≠ Remote set value		Local set value = Remote set value		Local set value = Remote set value
SV tracking unused	Local set value ≠ Remote set value		Local set value ≠ Remote set value		Local set value ≠ Remote set value

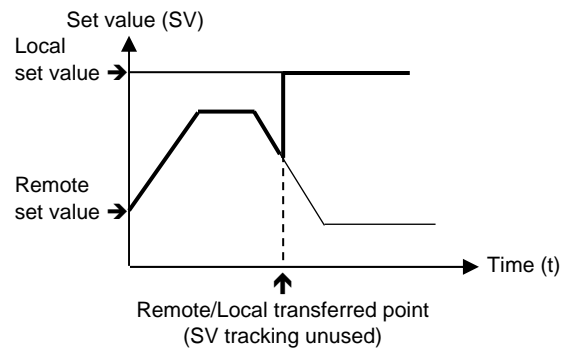
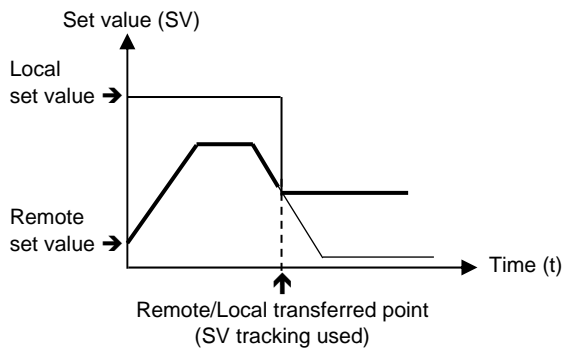

8.12 Control 1 (F51) Control 2 (F52)

■ Control action type selection (1. oS, 2. oS)

Use to select Direct action/Reverse action.

Data range: 0: Direct action
1: Reverse action

Factory set value: Input 1_control action type selection (1. oS): 1
Input 2_control action type selection (2. oS): 1

Control action type: Direct action: The Manipulated output value (MV) increases as the Measured value (PV) increases. This action is used generally for cool control.

Reverse action: The Manipulated output value (MV) decreases as the Measured value (PV) increases. This action is used generally for heat control.

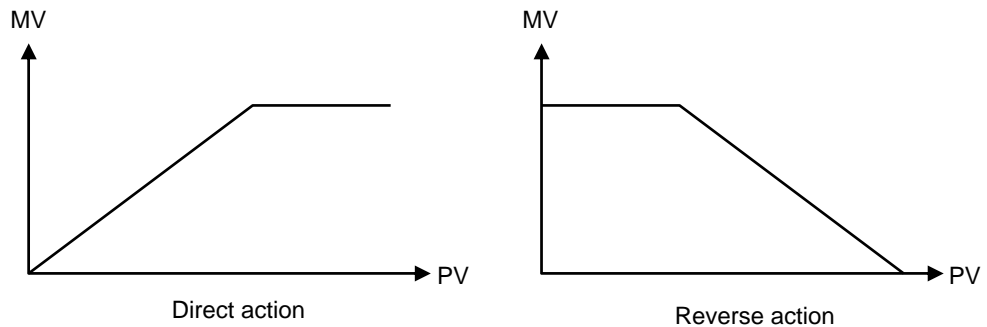

■ Integral/Derivative time decimal point position selection (1.IddP, 2.IddP)

Use to select a decimal point position of Integral time and Derivative time in PID control.

Data range: 0: No decimal place
1: One decimal place
2: Two decimal places

Factory set value: Input 1_integral/derivative time decimal point position selection (1.IddP): 2
Input 2_integral/derivative time decimal point position selection (2.IddP): 2

Related parameters: Integral time (P. 37), Derivative time (P. 37)

■ Derivative gain (1. dGA, 2. dGA)

Use to set a gain used for derivative action in PID control. Derivative gain should not be changed under ordinary operation.

Data range: 0.1 to 10.0
Factory set value: Input 1_derivative gain (1. dGA): 6.0
Input 2_derivative gain (2. dGA): 6.0



Under ordinary operation, it is not necessary to change Derivative gain set value.

■ ON/OFF action differential gap (upper) (1. oHH, 2. oHH)

Use to set the ON/OFF control differential gap (upper).

Data range: 0 to Input span
(Varies with the setting of the Decimal point position)

Factory set value: Input 1_ON/OFF action differential gap (upper) (1. oHH):
Pressure sensor input: 1.0 MPa
Voltage (V)/Current (I) inputs: 0.1 % of input span

Input 2_ON/OFF action differential gap (upper) (2. oHH):
TC/RTD inputs: 1.0 °C [°F]
Voltage (V)/Current (I) inputs: 0.1 % of input span

Related parameters: ON/OFF action differential gap (lower) (P. 88)

ON/OFF Action Differential Gap:

ON/OFF control is possible when the Proportional band is set to “0” or “0.0.” In ON/OFF control with Reverse action, when the Measured value (PV) is smaller than the Set value (SV), the Manipulated output (MV) is 100 % or ON. When the PV is higher than the SV, the MV is 0 % or OFF. Differential gap setting prevents control output from repeating ON and OFF too frequently.

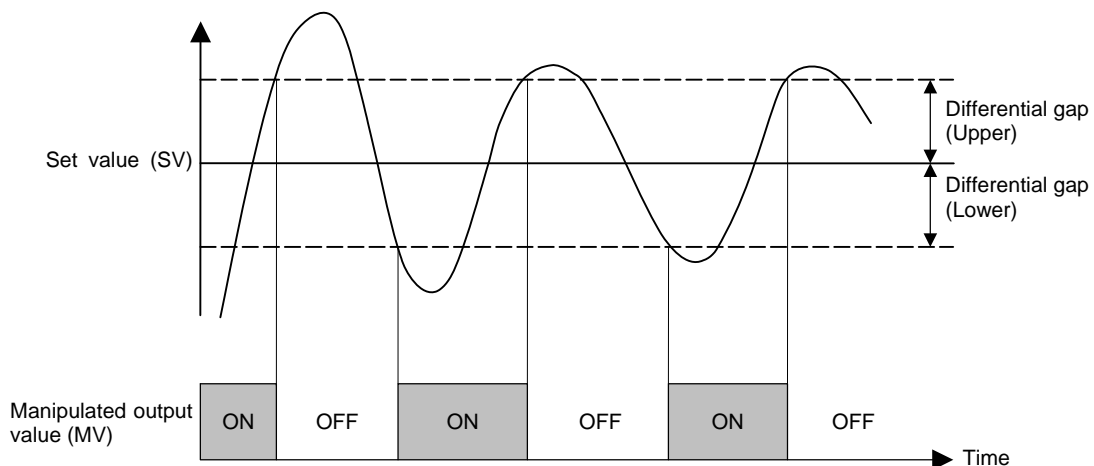

■ ON/OFF action differential gap (lower) (1. oHL, 2. oHL)

Use to set the ON/OFF control differential gap (lower).

Data range: 0 to Input span
(Varies with the setting of the Decimal point position)

Factory set value: Input 1_ON/OFF action differential gap (lower) (1. oHL):
Pressure sensor input: 1.0 MPa
Voltage (V)/Current (I) inputs: 0.1 % of input span

Input 2_ON/OFF action differential gap (lower) (2. oHL):
TC/RTD inputs: 1.0 °C [°F]
Voltage (V)/Current (I) inputs: 0.1 % of input span

Related parameters: ON/OFF action differential gap (upper) (P. 88)

Description of function: Refer to **ON/OFF action differential gap (upper)**.

■ Action at input error (high) (1. AoVE, 2. AoVE)

Use to select the action when the measured value reaches the Input error determination point (high).

Data range: 0: Normal control
1: Manipulated output value at input error (PSM)

Factory set value: Input 1_action at input error (high) (1. AoVE): 0
Input 2_action at input error (high) (2. AoVE): 0

Related parameters: Input error determination point (high) (P. 70),
Manipulated output value at input error (P. 90)

Input Error Determination:

Example: Input range: 0.0 to 250.0 MPa
Input error determination point (high): 240.0 MPa
Input error determination point (low): 5.0 MPa

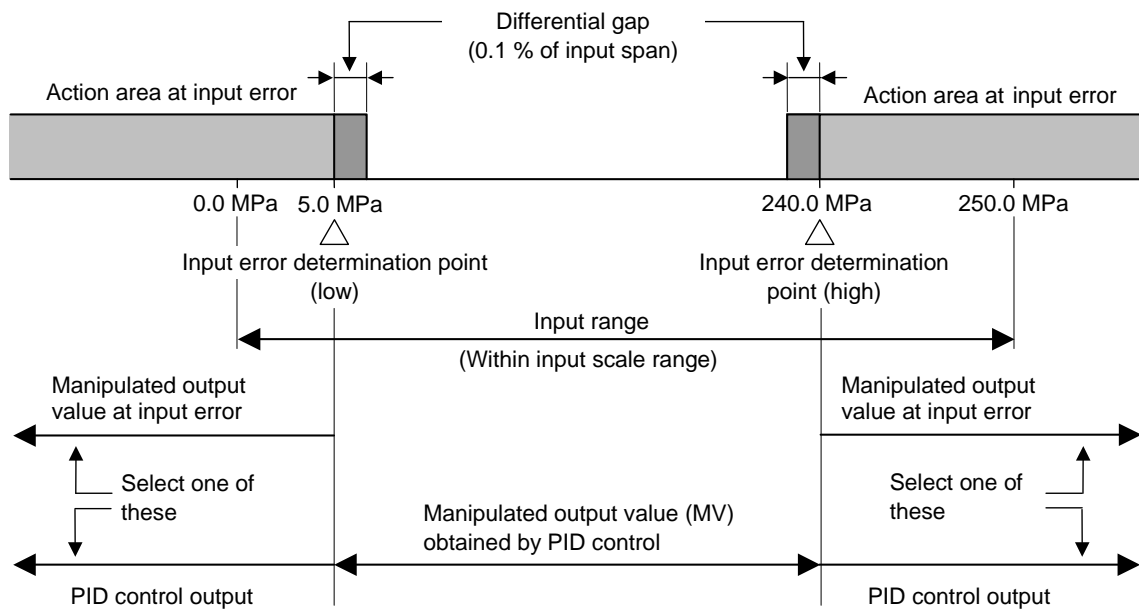

■ Action at input error (low) (1. AUnE, 2. AUnE)

Use to select the action when the measured value reaches the Input error determination point (low).

Data range: 0: Normal control
1: Manipulated output value at input error (PSM)

Factory set value: Input 1_action at input error (low) (1. AUnE): 0
Input 2_action at input error (low) (2. AUnE): 0

Related parameters: Input error determination point (low) (P. 71),
Manipulated output value at input error (P. 90)

Description of function: Refer to **Action at input error (high)**.

■ Manipulated output value at input error (1. PSM, 2. PSM)

When the measured value reaches Input error determination point and Action at input error is set to “1”, this manipulated value is output.

Data range: -5.0 to +105.0 %

Factory set value: Input 1_manipulated output value at input error (1. PSM): -5.0
Input 2_manipulated output value at input error (2. PSM): -5.0

Related parameters: Input error determination point (high) (P. 70), Input error determination point (low) (P. 71),
Action at input error (high) (P. 89), Action at input error (low) (P. 89)

■ Manipulated output value when transferred to Auto from Manual (1. PSM', 2. PSM')

This is the final Manipulated output value used under Manual control when the control mode is transferred to Auto control from Manual control.

Data range: -5.0 to +105.0 %

Factory set value: —

Related parameters: MV transfer function (P. 92)



This manipulated output value is used as a manipulated output value under Manual control when transferred to Manual control from Auto control for event input with “MV transfer function: 1 (Used)” selected.

■ Output change rate limiter (up) (1. orU, 2. orU)

Use to set the Output change rate limiter (up) to limit of the variation of output is set.

Data range: 0.0 to 1000.0 %/second of manipulated output
0.0: Unused

Factory set value: Input 1_output change rate limiter (up) (1. orU): 0.0
Input 2_output change rate limiter (up) (2. orU): 0.0

Related parameters: Output change rate limiter (down) (P. 91), Output limiter high (P. 92),
Output limiter low (P. 92)

Output Change Rate Limiter:

The Output change rate limiter limits the variation of Manipulated output (MV) per second. This function is suitable for an application in which a sudden MV change is not acceptable.

Continued on the next page.

Continued from the previous page.

[Example]

The Output change rate limiter is effective.

- The MV reaches 100 % when the power is turned on to the controller and such a sudden output change is not acceptable in the application.
- A sudden output change occurs at the SV change and it is not acceptable in the application.

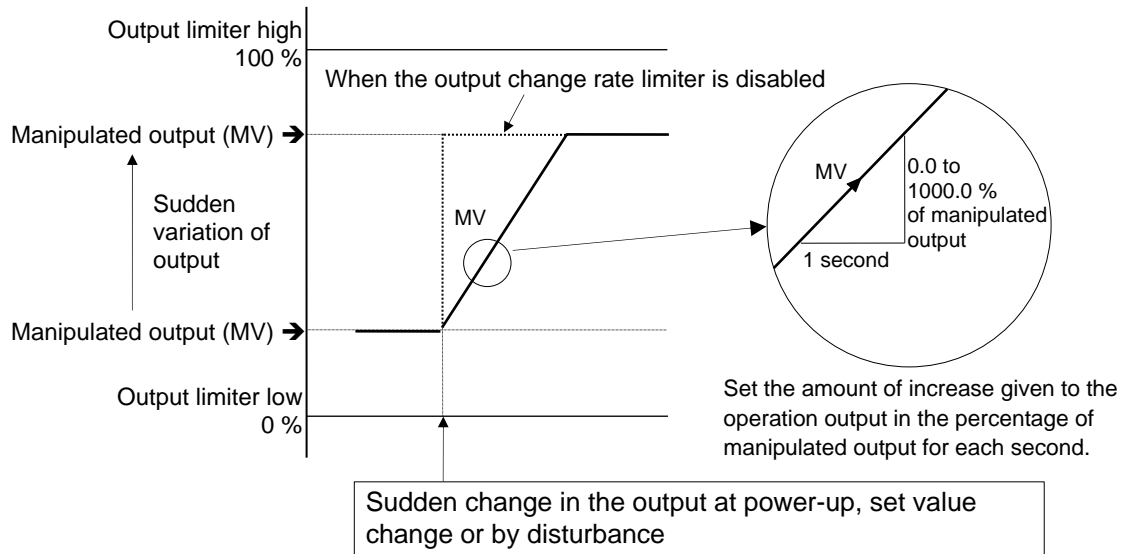

The output changes at specific rates set by Output change rate limiter (up) even under the situations where a sudden output change would occur without Output change rate limiter function. There is also independent Output change rate limiter (down).



If the Output change rate is set smaller, it will cause slow control response and affect Derivative action.



When the Output change rate limiter is used, you may not be able to obtain appropriate PID constants by Autotuning.



The Output change rate limiter is particularly effective when a sudden MV change may create uncontrollable situation cause a large current flow. Also, it is very effective current output or voltage output is used as control output.

■ Output change rate limiter (down) (1. ord, 2. ord)

Use to set the Output change rate limiter (down).

Data range: 0.0 to 1000.0 %/second of manipulated output
0.0: Unused

Factory set value: Input 1_output change rate limiter (down) (1. ord): 0.0
Input 2_output change rate limiter (down) (2. ord): 0.0

Related parameters: Output change rate limiter (up) (P. 90), Output limiter high (P. 92),
Output limiter low (P. 92)

Description of function: Refer to **Output change rate limiter (up)**.

■ Output limiter high (1. oLH, 2. oLH)

Use to set the high limit value of manipulated output.

Data range: Output limiter low to 105.0 %

Factory set value: Input 1_output limiter high (1. oLH): 105.0

Input 2_output limiter high (2. oLH): 105.0

Related parameters: Output change rate limiter (up) (P. 90), Output change rate limiter (down) (P. 91),
Output limiter low (P. 92)

Output Limiter:

This is the function which restricts the high and low limits of Manipulated output values (MV).

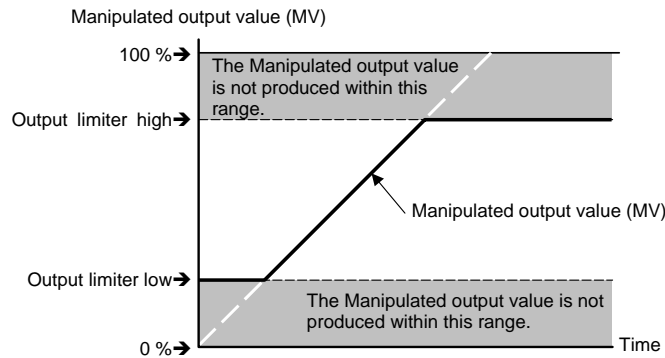

Output limiter is available for ON/OFF action.

■ Output limiter low (1. oLL, 2. oLL)

Use to set the low limit value of manipulated output.

Data range: -5.0 % to Output limiter high

Factory set value: Input 1_output limiter low (1. oLL): -5.0

Input 2_output limiter low (2. oLL): -5.0

Related parameters: Output change rate limiter (up) (P. 90), Output change rate limiter (down) (P. 91),
Output limiter high (P. 92)

Description of function: Refer to **Output limiter high**.



The setting items “1. PFF”, “1. PFFS”, “2. PFF” and “2. PFFS” displayed hereafter are not used in the HA430/930.

■ MV transfer function (1. MVTS, 2. MVTS)

The final Manipulated output value (MV) used under Manual control with the control mode transferred to Auto control from Manual control is stored to the Manipulated output value (\square PSM') when transferred to Auto control from Manual control. It is selected whether or not this Manipulated output value (MV) is used only as a Manipulated output value (MV) under Manual control when transferred to Manual control from Auto control for event input (DI).

Data range: 0: Unused

1: Used

Factory set value: Input 1_MV transfer function (1. MVTS): 0

Input 2_MV transfer function (2. MVTS): 0

Related parameters: Manipulated output value when transferred to Auto from Manual (P. 90),
Auto/Manual transfer (P. 108)



This function does not act as an original function when transferred to Manual control from Auto control through transfer operation by the direct key or on the operation mode screen.

8.13 Autotuning 1 (AT1) (F53) Autotuning 2 (AT2) (F54)

■ AT bias (1. ATb, 2. ATb)

Use to set a bias to move the set value only when Autotuning (AT) is activated.

Data range: -Input span to +Input span

Factory set value: Input 1_AT bias (1. ATb): 0

Input 2_AT bias (2. ATb): 0

Related parameters: PID/AT transfer (P. 101), AT action (P. 96)

Functional description:

The AT bias is used to prevent overshoot during Autotuning in the application which does not allow overshoot even during Autotuning. RKC Autotuning method uses ON/OFF control at the set value to calculate the PID values. However, if overshoot is a concern during Autotuning, the desired AT bias should be set to lower the set point during Autotuning so that overshoot is prevented.

Example: When AT bias is set to the minus (-) side.

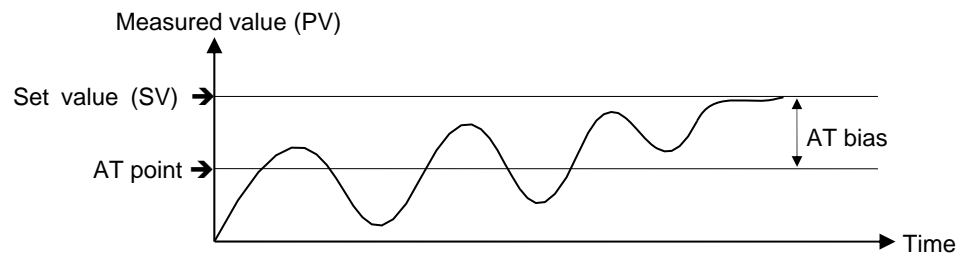

■ AT cycle (1. ATC, 2. ATC)

The number of ON/OFF cycles is selected when the Autotuning (AT) function is executed.

Data range: 0: 1.5 cycles
 1: 2.0 cycles
 2: 2.5 cycles
 3: 3.0 cycles

Factory set value: Input 1_AT cycle (1. ATC): 1
 Input 2_AT cycle (2. ATC): 1

Related parameters: PID/AT transfer (P. 101), AT action (P. 96)

Example: When the AT cycle is set to 1.5 cycle and the Autotuning (AT) function is executed just after the power is turned on.

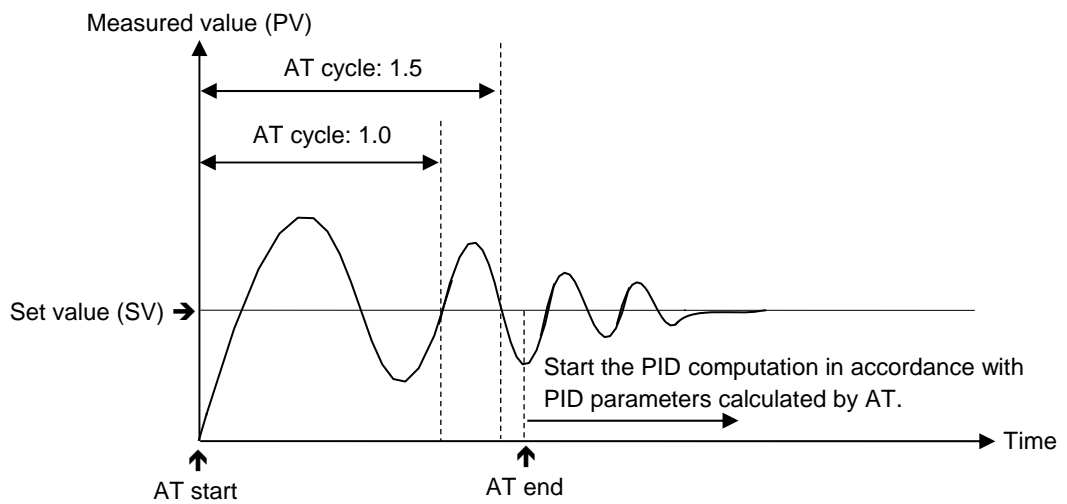

■ AT differential gap time (1. ATH, 2. ATH)

Use to set an ON/OFF action differential gap time for Autotuning (AT). This function prevents the AT function from malfunctioning caused by noise.

Data range: 0.00 to 50.00 seconds

Factory set value: Input 1_AT differential gap time (1. ATH): 0.10
Input 2_AT differential gap time (2. ATH): 0.10

Related parameters: PID/AT transfer (P. 101), AT action (P. 96)

Functional description:

In order to prevent the output from chattering due to the fluctuation of a Measured value (PV) caused by noise during Autotuning, the output on or off state is held until AT differential gap time has passed after the output on/off state is changed to the other. Set AT differential gap time to “ $1/100 \times$ Time required for temperature rise.”

Example:

A: AT cycle time the AT differential gap time set to 0.00 second

The output chatters due to the fluctuation of the Measured value (PV) caused by noise, and Autotuning (AT) function is not able to monitor appropriate cycles to compute suitable PID values.

B: AT cycle time when the AT differential gap time is set to “Time corresponding to 0.25 cycles.” The fluctuation of a Measured value (PV) caused by noise is ignored and as a result Autotuning (AT) function is able to monitor appropriate cycles to compute suitable PID values.

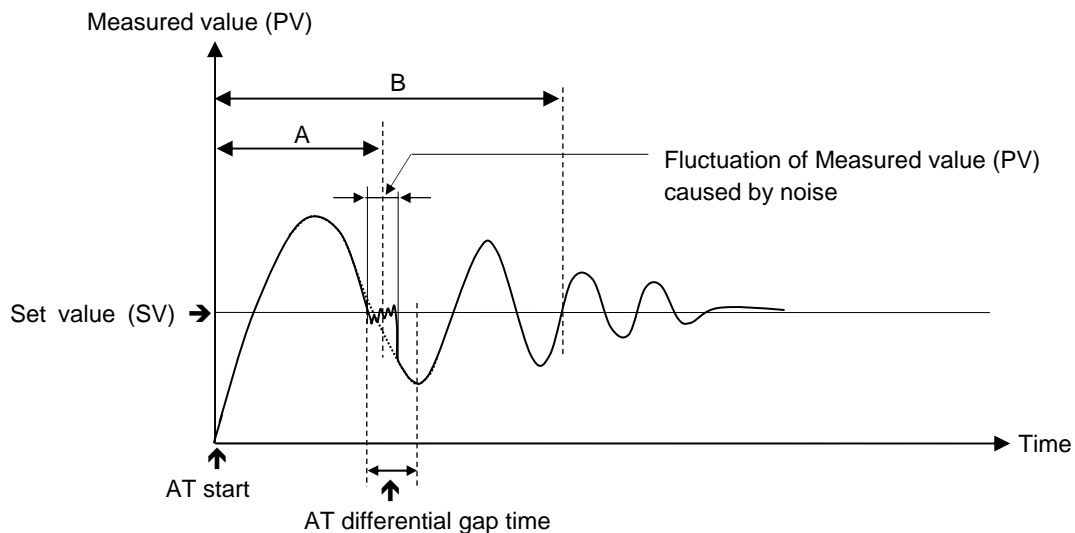

The factory set value of the AT cycle is 2 cycles.



Function block F55 (Including setting item) displayed hereafter is not used in the HA430/930.

■ AT action (1. ATt, 2. ATt)

Use to select the Autotuning (AT) function.

Data range: 0: AT function (PID)
(AT result is reflected to derivative time.)
1: AT function (PI)
(No AT result is reflected to derivative time.)
2: No AT function

Factory set value: Input 1_AT action (1. ATt): 2
Input 2_AT action (2. ATt): 2

Related parameters: PID/AT transfer (P. 101)

Autotuning (AT) function:

Autotuning (AT) automatically measures, calculates and sets the optimum PID (PI) constants. The following conditions are necessary to carry out autotuning and the conditions which will cause the autotuning to stop.

■ AT start

First, select the AT function type on the AT action selecting screen. Next, check that all of the following conditions are satisfied. The autotuning (AT) is executed on the PID/AT transfer screen in RUN mode. (Refer to P. 101)

- Operation mode conditions are as follows:
 - Auto/Manual transfer Auto mode
 - Remote/Local transfer Local mode
 - PID/AT transfer PID control
 - RUN/STOP transfer Control RUN
- The Measured value (PV) is without input error range [Input error determination point (high) > Measured value (PV) > Input error determination point (low)].
- The Output limiter high is 0.1 % or higher and the Output limiter low is 99.9 % or less.



When the Autotuning is finished, the controller will automatically returns to PID (PI) control.

■ AT cancellation

The Autotuning is canceled if any of the following conditions exist.

- When the Temperature set value (SV) is changed.
- When the Output limiter high or the Output limiter low is changed.
- When the PV bias, the PV digital filter, or the PV ratio is changed.
- When the Auto/Manual mode is changed to the Manual mode.
- When the Remote/Local mode is changed to the Remote mode.
- When the Measured value (PV) goes to input error range [Measured value (PV) \geq Input error determination point (high) or Input error determination point (low) \geq Measured value (PV)].
- When the power failure occurs.
- When the instrument is in the FAIL state.
- When the PID/AT transfer is changed to the PID control.
- When the RUN/STOP mode is changed to the control STOP.



If the AT is canceled, the controller immediately changes to PID (PI) control. The PID (PI) values will be the same as before AT was activated.

8.14 Communication Function (F60)



The setting items “Car” and “Cab” displayed hereafter are not used in the HA430/930.

■ Communication protocol selection (CMPS2)

Use to select the protocol of Communication.

Data range: 0: RKC communication
 1: Modbus 1 (Data transfer: In order of low-order word from high-order word)
 2: Modbus 2 (Data transfer: In order of high-order word from low-order word)
 10: CC-Link (1 station occupied 1 time)
 11: CC-Link (1 station occupied 4 times)
 12: CC-Link (1 station occupied 8 times)
 13: CC-Link (4 stations occupied 1 time)

Factory set value: 0 (RKC communication), 2 (Modbus)

Related parameters: Device address (P. 46), Communication speed (P. 46), Data bit configuration (P. 46), Interval time (P. 47)



Communication (optional) must be specified when ordering.



If the Communication function is for PROFIBUS or DeviceNet, the selection of the Communication protocol (CMPS2) becomes invalid.



For the details of communication functions (RKC communication/Modbus), refer to the **Communication Instruction Manual (IMR01N13-E□)**. *

* Refer to **Communication Instruction Manual (IMR01N14-E□)** for PROFIBUS, **Communication Instruction Manual (IMR01N15-E□)** for DeviceNet, and **Communication Instruction Manual (IMR01N21-E□)** for CC-Link.

8.15 Set Value (SV) (F70)

■ Setting change rate limiter unit time (SVrT)

Set the time unit for Setting change rate limiter (up/down).

Data range: 1 to 3600 seconds

Factory set value: 60

Related parameters: Setting change rate limiter (up) (P. 38), Setting change rate limiter (down) (P. 39)

■ Soak time unit selection (STdP)

Use to select the time unit for Area soak time.

Data range: 0: 0 hour 00 minutes 00 second to 9 hours 59 minutes 59 seconds
 2: 0 minutes 00.00 seconds to 9 minutes 59.99 seconds

Factory set value: 2

Related parameters: Area soak time (P. 40)

8.16 Set Value 1 (SV1) (F71) Set Value 2 (SV2) (F72)

■ Setting limiter high (1. SLH, 2. SLH)

Use to set a high limit of the set value.

Data range: Setting limiter low to Input scale high

Factory set value: Input 1_setting limiter high [1.SLH]: Input 1_input scale high
Input 2_setting limiter high [2.SLH]: Input 2_input scale high

Related parameters: Decimal point position (P. 69), Input scale high (P. 69), Setting limiter low (P. 98)

Setting Limiter: Setting limiter is to set the range of the Set value (SV).

Example: The input range (input scale range) is from 0.0 to 250.0 MPa, the Setting limiter high is 200.0 MPa, and the Setting limiter low is 20.0 MPa.

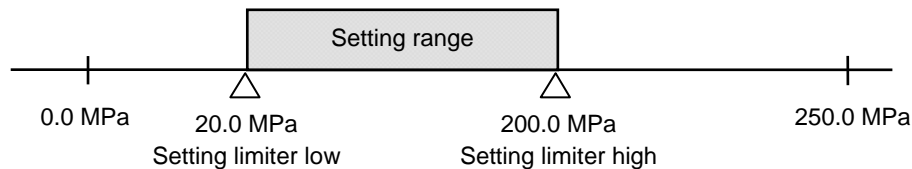

■ Setting limiter low (1. SLL, 2. SLL)

Use to set a low limit of the set value.

Data range: Input scale low to Setting limiter high

Factory set value: Input 1_setting limiter low [1.SLL]: Input 1_input scale low
Input 2_setting limiter low [2.SLL]: Input 2_input scale low

Related parameters: Decimal point position (P. 69), Input scale low (P. 70), Setting limiter high (P. 98)

Description of function: Refer to **Setting limiter high**.

■ PV transfer function (1. PVTs, 2. PVTs)

It is selected whether or not PV with the control mode transferred to Auto control from Manual control is used as SV. It is possible to prevent a Manipulated output value (MV) from its sudden change by substituting PV for SV.

Data range: 0: Unused
1: Used

Factory set value: Input 1_PV transfer function (1. PVTs): 0
Input 2_PV transfer function (2. PVTs): 0

Related parameters: Auto/Manual transfer (P. 108)

8.17 System Information Display (F91)

System information (refer to below) can be checked on Function block F91.

Upper display: Character of the parameter

Lower display: value

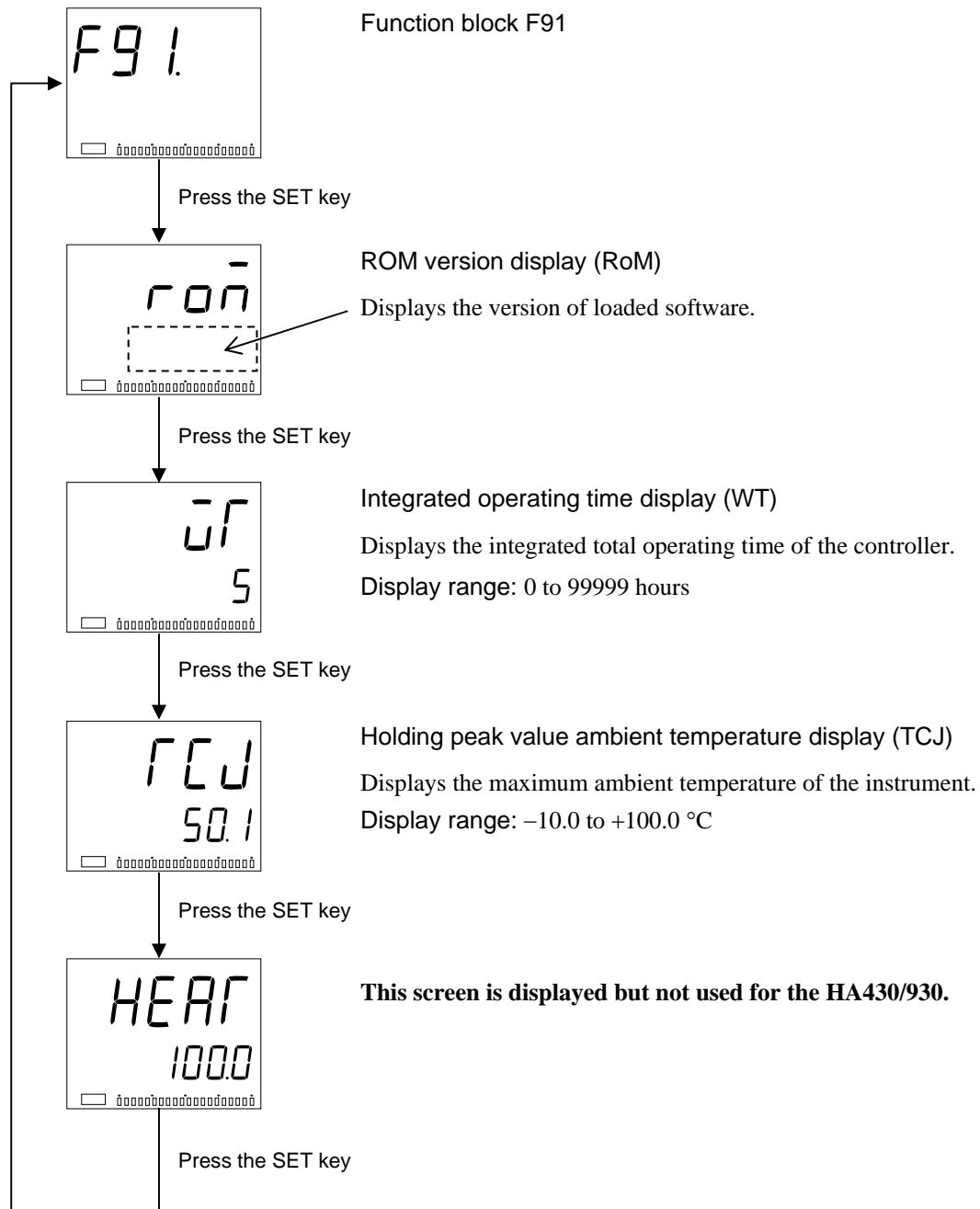

9. OPERATION







9.1 Control RUN and STOP

There is no power switch on this instrument, and the instrument starts operation immediately following initial power-ON (Factory set value: RUN).

There are parameters in Engineering mode which cannot be changed when the controller is in RUN mode. Press the direct key (R/S) to change the RUN/STOP mode from RUN to STOP when a change for the parameters in Engineering mode is necessary. Refer to **8. ENGINEERING MODE (P. 50)** for details. When RUN/STOP mode is changed from STOP to RUN, the controller starts control in the way set in **Hot/Cold start selection** of the Engineering mode (P. 85).

 For detail of RUN/STOP transfer, refer to **9.6 RUN/STOP Transfer (P. 112)**.

■ Operation under control RUN mode

- To change display contents in the monitoring state, go to SV setting & Monitor mode.
 **5. SV SETTING & MONITOR MODE (P. 30), 9.3 Monitoring Display in Operation (P. 102)**
- To change the Set value (SV), go to SV setting & Monitor mode.
 **5. SV SETTING & MONITOR MODE (P. 30)**
- To change parameters related to control, go to the Parameter setting mode.
 **6. PARAMETER SETTING MODE (P. 32), 7. SETUP SETTING MODE (P. 42)**
- To change the control Memory area, go to SV setting & Monitor mode.
 **5. SV SETTING & MONITOR MODE (P. 30)**
- To activate Autotuning (AT), go to the Operation mode.
 **AT action (P. 96), 9.2 Configuration of Operation Mode (P. 101)**
- To switch Auto/Manual, go to the Operation mode, or press the direct key (A/M).
 **9.2 Configuration of Operation Mode (P. 101), 9.4 Auto/Manual Transfer (P. 108)**
- To switch Remote/Local, go to the Operation mode, or press the direct key (R/L).
 **9.2 Configuration of Operation Mode (P. 101), 9.5 Remote/Local Transfer (P. 111)**

■ Display at control STOP

The STOP character is displayed on the Measured value (PV1/PV2) display unit while being stopped.

The display unit to display the STOP character is selectable.

Go to **“STOP display selection”** in the Engineering mode (P. 63).

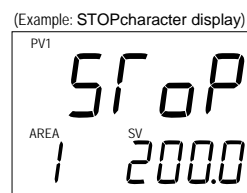

9.2 Configuration of Operation Mode

■ Display Sequence

The operation mode is used to select the operation modes (PID/AT, Auto/Manual, Remote/Local, RUN/STOP) of the instrument. Every time the SET key or the shift key is pressed, the display goes to the next parameters.

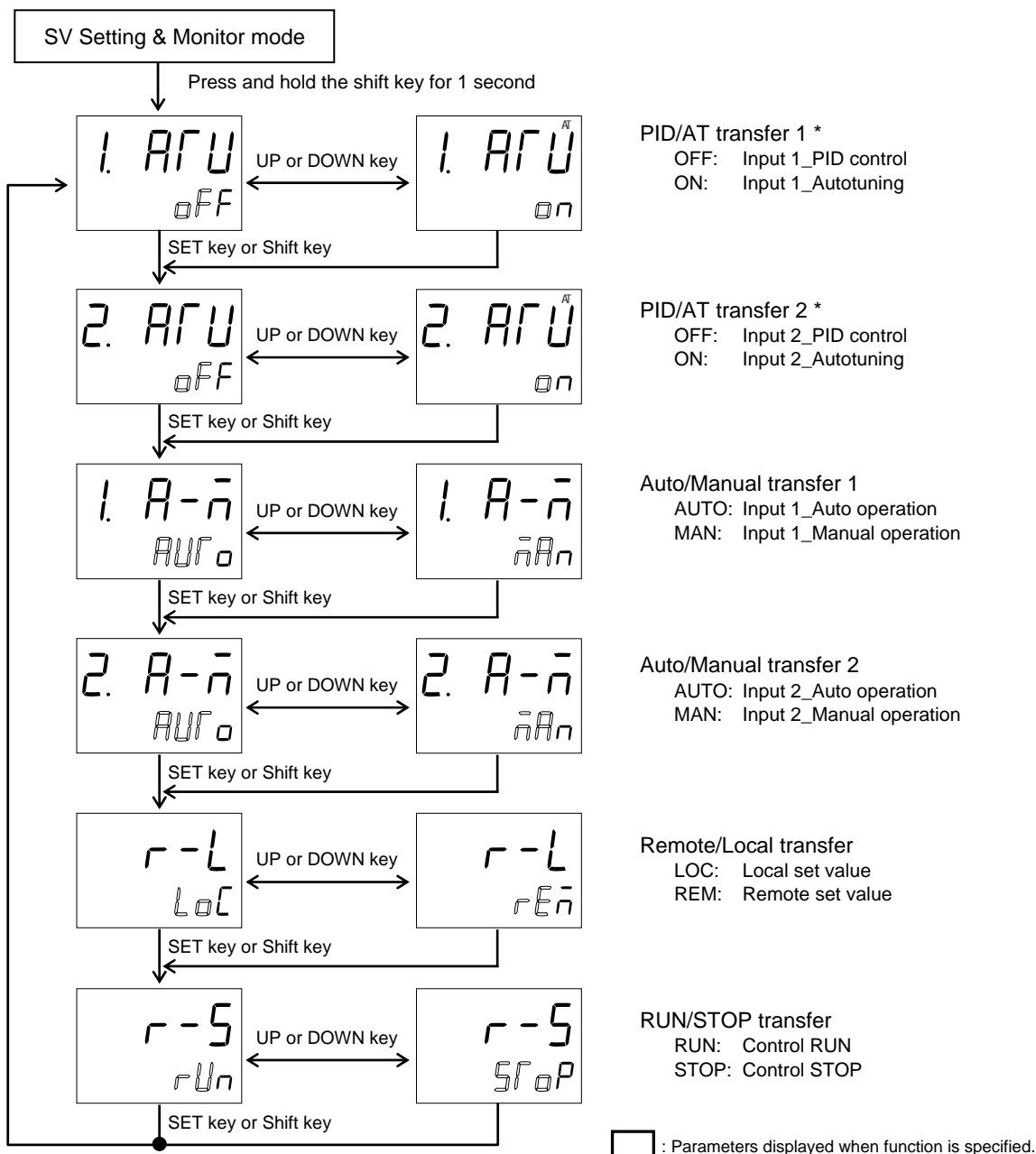

* No PID/AT transfer is valid prior to factory shipment. The transfer becomes valid only when “1: AT function (PI)” or “0: AT function (PID)” is selected in AT action selection. Refer to P. 96.



Auto/Manual, Remote/Local, RUN/STOP transfer is possible via respective Direct key.



To return the SV setting & Monitor mode, press and hold the shift key for 1 second, or press the shift key while pressing the SET key.



If the key is not pressed within 1 minute, the display will automatically return to the SV setting & Monitor mode.

9.3 Monitoring Display in Operation

In SV setting & Monitor mode, the following operations are possible.

Change the Set value (SV)

Change Memory area

Monitor the Measured value (PV) and the Manipulated value (MV), etc.

Use this mode during normal operation.

■ Display Sequence

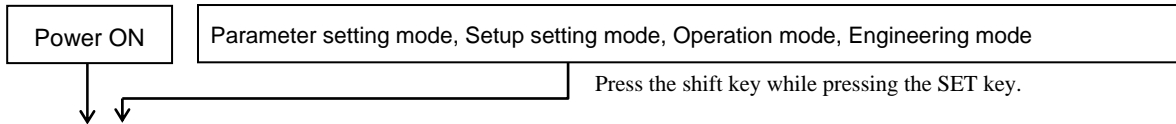

Input 1_measured value (PV1)/set value (SV1) monitor

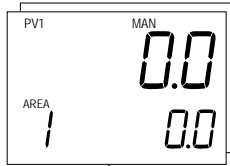

SET key

Measured value 1 (PV1)

Set value 1 (SV1)

One of set value, Input 1_manipulated output value (MV1) or remote set value can be displayed.

Local state: The set value is displayed.

Remote state: The remote set value is displayed.

Manual operation: The Manipulated output value (MV1) of Input 1 can be set.

Setting range: Input 1_output limiter low to Input 1_output limiter high

An MV scaling value (motor RPM) is displayed in the monitor state.

It is also possible to manually change the MV scaling value.

Display range: MV scaling low to MV scaling high



MV scaling function

Scaling of an Input 1_manipulated output value (MV1) is conducted in Engineering mode.

- F10_Decimal point position of MV scaling (MVdP)
- F10_MV scaling low (MVLS)
- F10_MV scaling high (MVHS)

Example: When scaling of an input 1_manipulated output value (MV1) is conducted to obtain the number of motor revolutions from 0.0 to 80.0 rpm

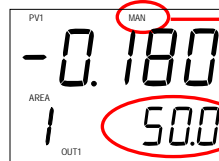

MAN lamp ON

Decimal point position of MV scaling: One decimal place

Input 1_MV scaling low (MV1 = 0.0 %): 0.0 rpm

Input 1_MV scaling high (MV1 = 100.0 %): 80.0 rpm

Displays any value obtained after scaling of a Manipulated output value (MV1).

In addition, any value obtained after scaling of a Manipulated output value (MV1) can be changed.

The number of motor revolutions is increased from 50.0 to 60.0 rpm.

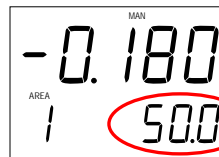

Keep pressing the UP key until a value of 60.0 is attained.

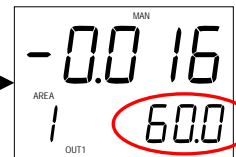

When the Setting change rate limiter is set and the SV is changed, the SV changes at specific rates in the display.

: Parameters related to multi-memory area function

: Parameters displayed when function is specified.

Continued on the next page.



Continued from the previous page.



Input 2_measured value (PV2)/set value (SV2) monitor

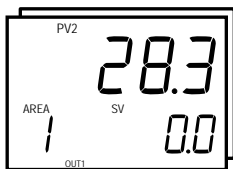

Measured value 2 (PV2)
 Set value 2 (SV2)
 In the Manual operation, the Manipulated output value (MV2) of Input 2 can be set.
 Setting range: Input 2_output limiter low to Input 2_output limiter high

SET key



When the Setting change rate limiter is set and the SV is changed, the SV changes at specific rates in the display.

Input 1_measured value (PV1)/Input 2_measured value (PV2) monitor

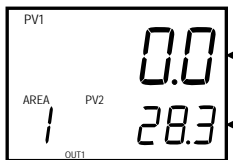

Measured value 1 (PV1)
 Measured value 2 (PV2)

SET key

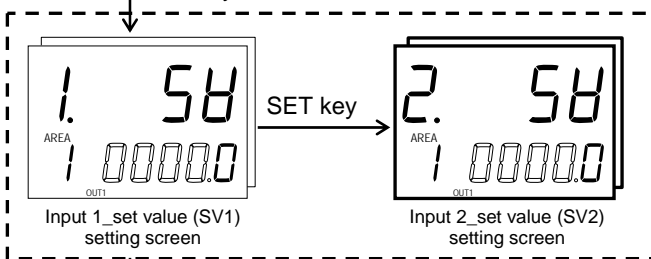

SET key

Remote input value monitor

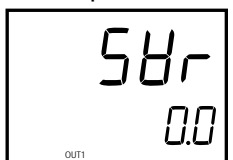

Displays the remote set value which is the control target value in the Remote (REM) mode.
 Displayed only when the Remote input function is provided.
 Display range: Input 1_setting limiter low to Input 1_setting limiter high

SET key

PV1 peak hold value monitor



The maximum PV value (peak value) of Input 1 is held and displayed. Displayed only when the hold function provided.
 Display range: Input 1_input scale low to Input 1_input scale high
 Peak hold function: Refer to the next page.

SET key

: Parameters related to multi-memory area function
 : Parameters displayed when function is specified.



Continued on the next page.

Continued from the previous page.

B

Peak hold function:

The Peak hold function is used to store (hold) the maximum (peak) measured value (PV). The peak hold value is updated regardless of the STOP or RUN state if the power to this controller is turned on. Each of this value is updated when the Measured value (PV) becomes more than the value now being held. However, if the following operation is performed, the value now being held is reset and as a result the Measured value (PV) just when reset becomes the peak hold value.

- When the power is turned on or it is turned on again
- When operation mode is changed from STOP to RUN
- When hold reset

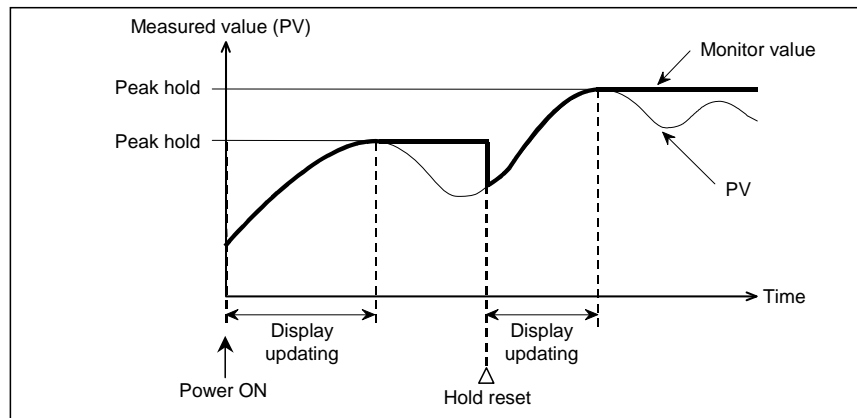

Peak hold value is not backed up.

PV1 bottom hold value monitor

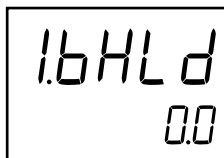

SET key

The minimum PV value (bottom value) of Input 1 is held and displayed. Displayed only when the hold function is provided.

Display range: Input 1_input scale low to Input 1_input scale high

Bottom hold function:

The Bottom hold function is used to store (hold) the minimum (bottom) measured value (PV). The bottom hold value is updated regardless of the STOP or RUN state if the power to this controller is turned on. Each of this value is updated when the Measured value (PV) becomes less than the value now being held. However, if the following operation is performed, the value now being held is reset and as a result the Measured value (PV) just when reset becomes the bottom hold value.

- When the power is turned on or it is turned on again
- When operation mode is changed from STOP to RUN
- When hold reset

: Parameters related to multi-memory area function
 : Parameters displayed when function is specified.

C

Continued on the next page.

Continued from the previous page.

C

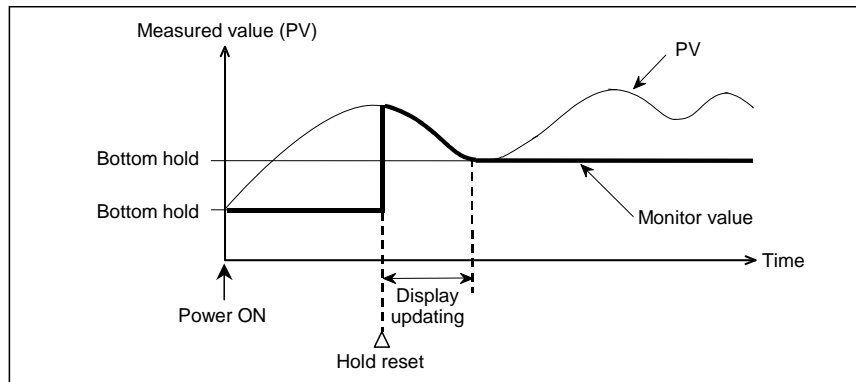

Bottom hold value is not backed up.

PV1 hold reset

1.HL dr

SET key

Input 1_peak and bottom hold value is reset when the UP and DOWN keys a simultaneously pressed. Displayed only when the Hold function is provided.

Hold reset can be made by Event input (optional). Hold resetting by Event input is set by selecting the **Event input logic selection** within the Engineering mode on page 73.

PV2 peak hold value monitor

2.PHL d
0.0

SET key

The maximum PV value (peak value) of Input 2 is held and displayed. Displayed only when the Hold function is provided.

Display range: Input 2_input scale low to Input 2_input scale high

Peak hold function: Refer to **PV1 peak hold value monitor (P. 104)**

PV2 bottom hold value monitor

2.bHL d
0.0

SET key

The minimum PV value (bottom value) of Input 2 is held and displayed. Displayed only when the Hold function is provided.

Display range: Input 2_input scale low to Input 2_input scale high

Bottom hold function: Refer to **PV1 bottom hold value monitor (P. 104)**

PV2 hold reset

2.HL dr

SET key

Input 2_peak and bottom hold value is reset when the UP and DOWN keys a simultaneously pressed. Displayed only when the Hold function is provided.

Hold reset can be made by Event input (optional). Hold resetting by Event input is set by selecting the **Event input logic selection** within the Engineering mode on page 73.

: Parameters related to multi-memory area function
 : Parameters displayed when function is specified.

D

Continued on the next page.

Continued from the previous page.



Input 1_manipulated output value (MV1) monitor

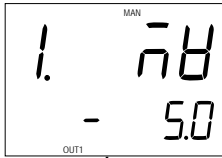

Input 1_manipulated output value (MV1) of 0 to 100 % is displayed as a value which is made scaling to the motor RPM.

Display range: MV scaling low to MV scaling high
 Related parameters: Decimal point position of MV scaling (P. 64),
 MV scaling low (P. 64), MV scaling high (P. 65)

SET key



When at a high MV scaling limit value of 100.0 and at a low MV scaling limit value of 0.0, MV1 is displayed.

When set to “high MV scaling limit value = low MV scaling limit value”, the zero value is displayed.

Input 2_manipulated output value (MV2) monitor

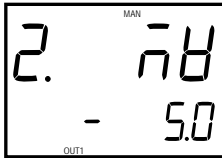

Displays Input 2_manipulated output value (MV2).
 Displayed only when the Input 2_manipulated output value (MV2) function is provided.
 Display range: -5.0 to +105.0 %

SET key

Event monitor

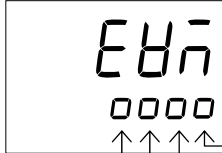

"o" corresponding to each Event is lit when the event is turned ON.

- ↑ Event 1 (EV1)
- ↑ Event 2 (EV2)
- ↑ Event 3 (EV3) or Control loop break alarm 1 (LBA1)
- ↑ Event 4 (EV4) or Control loop break alarm 2 (LBA2)

SET key

Interlock release

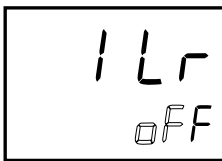

Displays the interlock status. Displayed only when the hold interlock is provided. Interlock status is release when the UP and DOWN keys a simultaneously pressed.

on: Interlock
 off: Interlock release

Inerlock function:
 The Interlock action holds the event state even if the measured value is out of the event zone after it enters the event zone once.

SET key

: Parameters related to multi-memory area function
 : Parameters displayed when function is specified.



Continued on the next page.

Continued from the previous page.

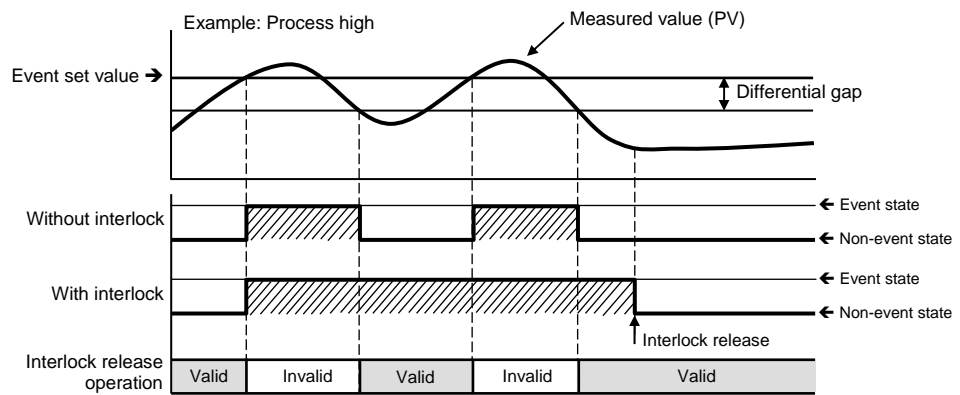

Interlock release can be made by Event input (optional). Interlock resetting by Event input is set by selecting the **Event input logic selection** within the Engineering mode on page 73.

Memory area selection

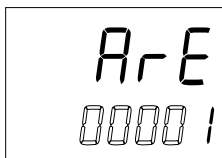

Selects the Memory area (control area) used for control.

Setting range: 1 to 16

The Memory area selection can be made by Event input (optional).

9.7 Control Area Transfer (P. 114)

SET key

Memory area soak time monitor

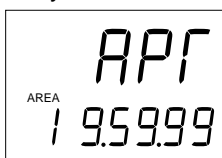

Monitors the time elapsed for memory area operation (soak time) when Ramp/Soak control by using Multi-memory area is performed.

Display range: 0 minute 00.00 second to 9 minutes 59.99 seconds or
0 hour 00 minute 00 second to 9 hours 59 minutes 59 seconds

Monitoring Example:

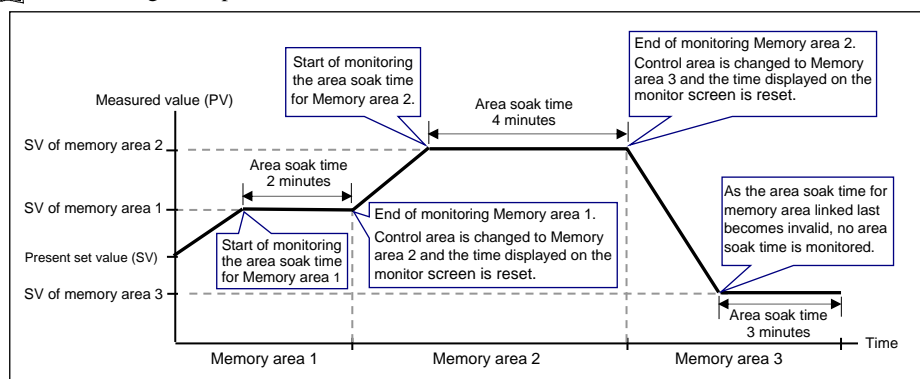

SET key



CC-Link communication status

Displays the CC-Link communication status.

Status number

For the CC-Link status number and its contents, refer to **Communication Instruction Manual [CC-Link] (IMR01N21-E□)**.

SET key

Retrun to Input 1_measured value (PV1)/set value (SV1) monitor screen

□ : Parameters related to multi-memory area function

□ □ : Parameters displayed when function is specified.

9.4 Auto/Manual Transfer

The Auto/Manual transfer can be made by Event input (optional) or Communication (optional) other than the key operation. For details of Auto/Manual transfer by communication, refer to the **Communication Instruction Manual (IMR01N13-E□)**.*

* Refer to **Communication Instruction Manual (IMR01N14-E□)** for PROFIBUS, **Communication Instruction Manual (IMR01N15-E□)** for DeviceNet, and **Communication Instruction Manual (IMR01N21-E□)** for CC-Link.

■ Auto/Manual transfer by Front key operation

Every time the UP key or the DOWN key is pressed, the Auto mode is changed to the Manual mode alternately.

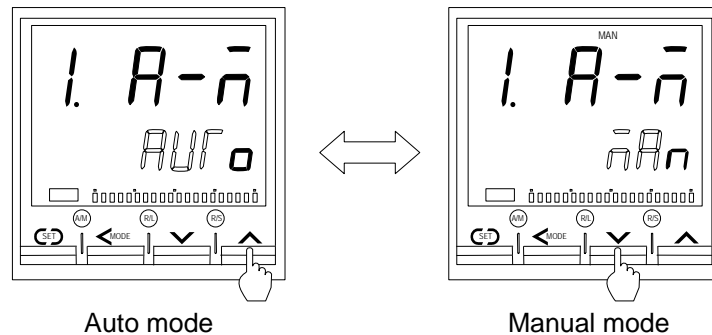

(The above figure is an image of Auto/Manual transfer of Input 1.)



When Auto/Manual mode is changed from Auto to Manual or from Manual to Auto, the balanceless-bumpless function is activated to prevent control disturbance caused by a sudden output change.

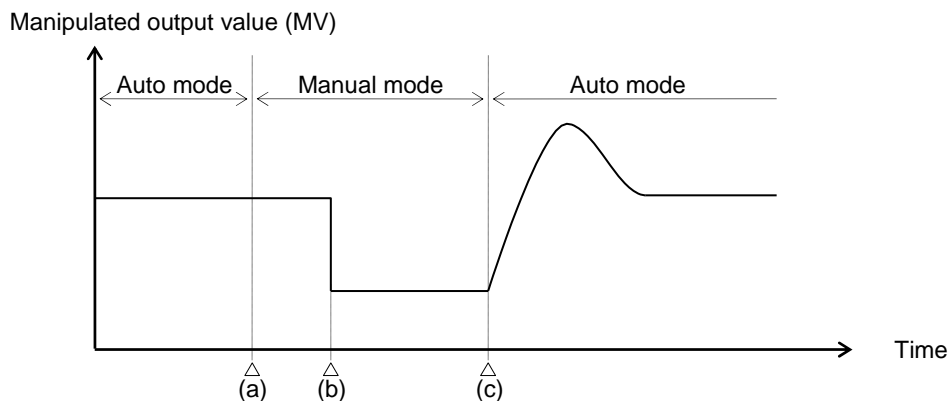

- (a) Transfer from Auto mode to Manual mode.
However, when the mode is transferred to Manual mode, the Manipulated output value used in Auto mode will be used as the Manual output value in Manual mode.
- (b) The Manipulated output value is changed (Manual mode function)
- (c) Transfer from Manual mode to Auto mode.
When the mode is transferred to Auto mode, the controller starts PID control based on the MV used in Manual mode.



For the Operation mode, refer to **9.2 Configuration of Operation Mode (P. 101)**.

■ Auto/Manual transfer by Direct key (A/M) operation

Every time the Auto/Manual (A/M) transfer key is pressed, the Auto mode is changed to the Manual mode alternately.

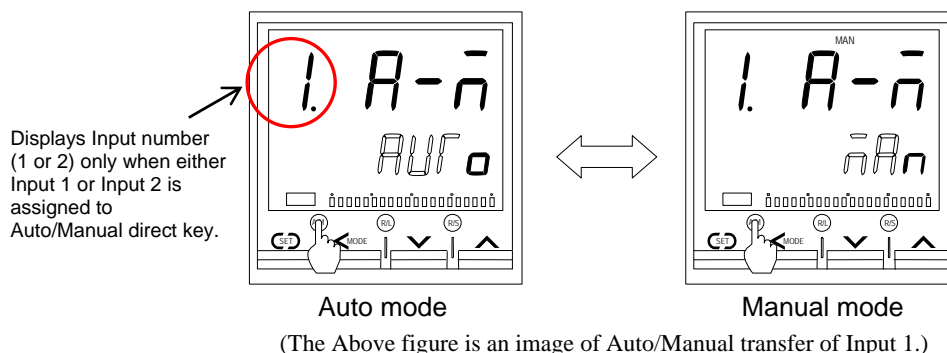

When Auto/Manual mode is changed from Auto to Manual or from Manual to Auto, the balanceless-bumpless function is activated to prevent control disturbance caused by a sudden output change.



Direct key operation setting can be changed in Engineering mode. For details, refer to **8.5 Direct Keys (F11)** on page 65.

■ Auto/Manual transfer by Event input

Auto/Manual transfer by the Event input is possible with the **Event input logic selection (P. 73)** of the Engineering mode. The table below shows the actual operation modes and lamp status under different combinations of settings by front key, communication and Event input.

Mode select from front key or communication	Event input state	Actual operation mode	Lamp state
Auto	Contact closed	Auto	MAN mode lamp OFF
	Contact open	Manual	MAN mode lamp ON
Manual	Contact closed		
	Contact open		



When the Event input is used for the setting change and the contact is closed, it takes approx. 0.5 seconds until the new setting is taken by the controller.



When Auto/Manual mode is changed from Auto to Manual or from Manual to Auto, the balanceless-bumpless function is activated to prevent control disturbance caused by a sudden output change.

■ **Procedure for setting the Manipulated output value (MV) in Manual mode**

When the controller is in Manual mode, the Manipulated output value (MV) can be manually set.

● **Setting procedure**

1. Make sure the Manual (MAN) mode lamp is lit.
2. Go to the “Input 1_PV1/SV1 monitor” screen in the SV setting & Monitor mode. Change the value by the UP and DOWN keys and then press the SET key to store the new setting.

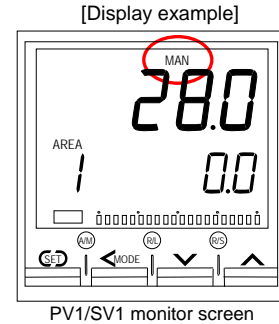

■ **Manipulated output value (MV) under Manual control is changed by Event input**

Any of the Event inputs (DI2 to DI4) enables the operation of Auto/Manual transfer, decrease/increase in Manipulated output value (motor RPM) under Manual control and resetting (manipulated output value = 0 %). The manipulation of these output values by the Event input is set by changing the **Event input logic selection (P. 73)** of the Engineering mode. The relationship between the event input contact state and the operation state is shown in the following.

● **Relationship between contact state and each operation state**

	Contact closed	Contact open	Key operation (equivalent)
Manual output down (Motor RPM down) ¹	Manual output down (Motor RPM down)	—	DOWN key
Manual output up (Motor RPM up) ²	Manual output up (Motor RPM up)	—	UP key
Manual output 0 % reset (Motor RPM reset) ³	Manual output 0 % reset (Motor RPM reset)	—	—

¹ Decreases Manipulated output value (motor RPM) under Manual control with contacts closed. (It takes about 25 seconds to 1000 digits.)

² Increases Manipulated output value (motor RPM) under Manual control with contacts closed. (It takes about 25 seconds to 1000 digits.)

³ The Manipulated output value (motor RPM) is reset to 0 % based on the edge discrimination of “open” to “closed.”

In addition, switched to “Manual Control” regardless of Auto/Manual transfer setting.



When the Event input is used for the setting change and the contact is closed, it takes approx. 0.5 seconds until the new setting is taken by the controller.

■ Remote/Local transfer by Event input

Remote/Local transfer by the Event input is possible with the **Event input logic selection (P. 73)** of the Engineering mode. The table below shows the actual operation modes and lamp status under different combinations of settings by front key, communication and Event input.

Mode select from front key or communication	Event input state	Actual operation mode	Lamp state
Remote	Contact closed	Remote	REM mode lamp ON
	Contact open	Local	REM mode lamp OFF
Local	Contact closed		
	Contact open		

 When the Event input is used for the setting change and the contact is closed, it takes approx. 0.5 seconds until the new setting is taken by the controller.

9.6 RUN/STOP Transfer

The RUN/STOP transfer can be made by Event input (optional) or Communication (optional) other than the key operation. For details of the RUN/STOP transfer by communication, refer to the **Communication Instruction Manual (IMR01N13-E□)**.*

* Refer to **Communication Instruction Manual (IMR01N14-E□)** for PROFIBUS, **Communication Instruction Manual (IMR01N15-E□)** for DeviceNet, and **Communication Instruction Manual (IMR01N21-E□)** for CC-Link.

- If the controller is transferred to STOP mode from RUN mode, the controller status is the same as the Power-off. However for the specification with current output (other than 0 to 20 mA) or voltage output, an output of -5 % is fed when at STOP.
- Operation when transferred to RUN from STOP is in accordance with the Hot/Cold start selection* setting.

* Cold start (factory shipment): The controller will automatically go to Manual mode and output from the low output limit value (factory set value: -5.0 %).

■ RUN/STOP transfer by Front key operation

Every time the UP key or the DOWN key is pressed, the RUN mode is changed to the STOP mode alternately.

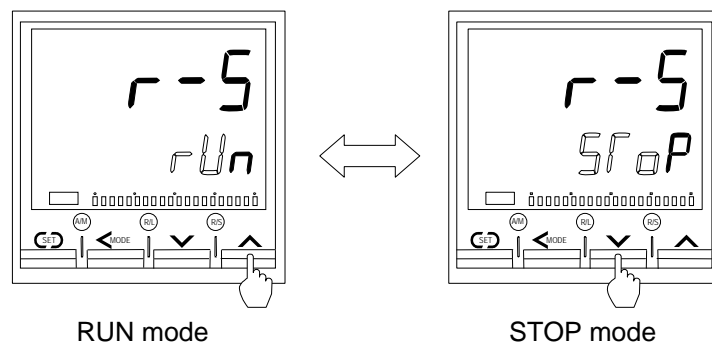

 For the Operation mode, refer to **9.2 Configuration of Operation Mode (P. 101)**.

■ RUN/STOP transfer by Direct key (R/S) operation

Every time the RUN/STOP (R/S) transfer key is pressed, the RUN mode is changed to the STOP mode alternately.

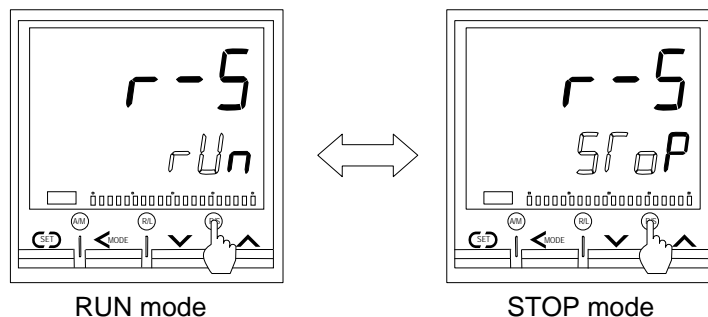

- 👉 Direct key operation setting can be changed in Engineering mode. For details, refer to **9.5 Direct Keys (F11)** on page 65.

■ RUN/STOP transfer by Event input

RUN/STOP transfer by the Event input is possible with the **Event input logic selection (P. 73)** of the Engineering mode. The table below shows the actual operation modes and displays under different combinations of settings by front key, communication and Event input.

Mode select from front key or communication	Event input state	Actual operation mode	State of STOP character display
RUN (Control RUN)	Contact closed	RUN	STOP is not displayed
	Contact open	STOP	dSfP
STOP (Control STOP)	Contact closed		eSfP
	Contact open	SfOP	

- 📖 **When the Event output is used for the setting change and the contact is closed, it takes approx. 0.5 seconds until the new setting is taken by the controller.**
- 📖 If the controller does not have Event input function, only “STOP” is displayed.

9.7 Control Area Transfer

The control area transfer can be made by Event input (optional) or Communication (optional) other than the key operation. For details of transfer by communication, refer to the **Communication Instruction Manual (IMR01N13-E□)**.*

* Refer to **Communication Instruction Manual (IMR01N14-E□)** for PROFIBUS, **Communication Instruction Manual (IMR01N15-E□)** for DeviceNet, and **Communication Instruction Manual (IMR01N21-E□)** for CC-Link.

■ Control area transfer by Front key operation

Press the UP key or the DOWN key to change the desired memory area number used for this control. Press the SET key to store the new setting.

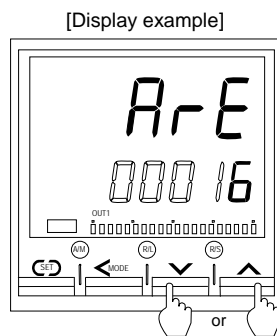

The Memory area number stored at last is taken as Control area.



The Memory area number (control area) can be changed at either RUN or STOP.



For the SV setting & Monitor mode, refer to **5. SV SETTING & MONITOR MODE (P. 30)**.

■ Control area transfer by Event input

Memory area (control area) transfer by the Event input is possible with the **Event input logic selection (P. 73)** of the Engineering mode. The table below shows the Event input status and selected memory numbers for Control area transfer.

Event input	Memory area number															
	1	2	3	4	5	6	7	8	9	10	11	12	13	14	15	16
DI 1	×	–	×	–	×	–	×	–	×	–	×	–	×	–	×	–
DI 2	×	×	–	–	×	×	–	–	×	×	–	–	×	×	–	–
DI 3	×	×	×	×	–	–	–	–	×	×	×	×	–	–	–	–
DI 4	×	×	×	×	×	×	×	×	–	–	–	–	–	–	–	–

×: Contact open

–: Contact closed



To store a new Memory area number as the Control area, close the DI for Memory area set.

9.8 Start Action at Recovering Power Failure

The operation of this instrument is not affected by a power failure of 20 ms or less. The control start mode at power recovery after more than 20 ms power failure can be selected as follows.

Power failure less than 3 seconds	Power failure 3 seconds or more
Hot start 1	Hot start 1
	Hot start 2
	Cold start
	Stop start
Hot start 2	Hot start 2
	Cold start
	Stop start
Cold start	Cold start
Stop start	Stop start

(Factory set value: Less than 3 seconds...Cold start, 3 seconds or more...Cold start)

- **Each start state is shown below.**

Hot start 1: the controller will return to the same operation mode and the same manipulated value which were used or calculated by the controller before power failure.

Hot start 2: the controller will return to the same operation mode which was used by the controller before power failure.

- In the Manual mode, the output value will be at the low output limit value.
- In the Auto mode, the controller will calculate the manipulated output value regardless that before power failure. So, the manipulated output varies.

Cold start: the controller will automatically go to Manual mode and output from the low output limit value.

Stop start: Started in the control stop (STOP) state regardless of the RUN mode (Auto/Manual) before power failure. Set to the RUN mode before power failure when changed to RUN from STOP by RUN/STOP selection.



Control start mode when the controller recovers from power failure can be selected in Engineering mode. For details, refer to **8.11 Control (F50)** on page 85.

9.9 Ramp/Soak Control

Ramp/Soak control is possible by using Area soak time, Link area number and Setting change rate limiter (up/down) in Parameter setting mode (P. 31). The operating procedure is described in the following.

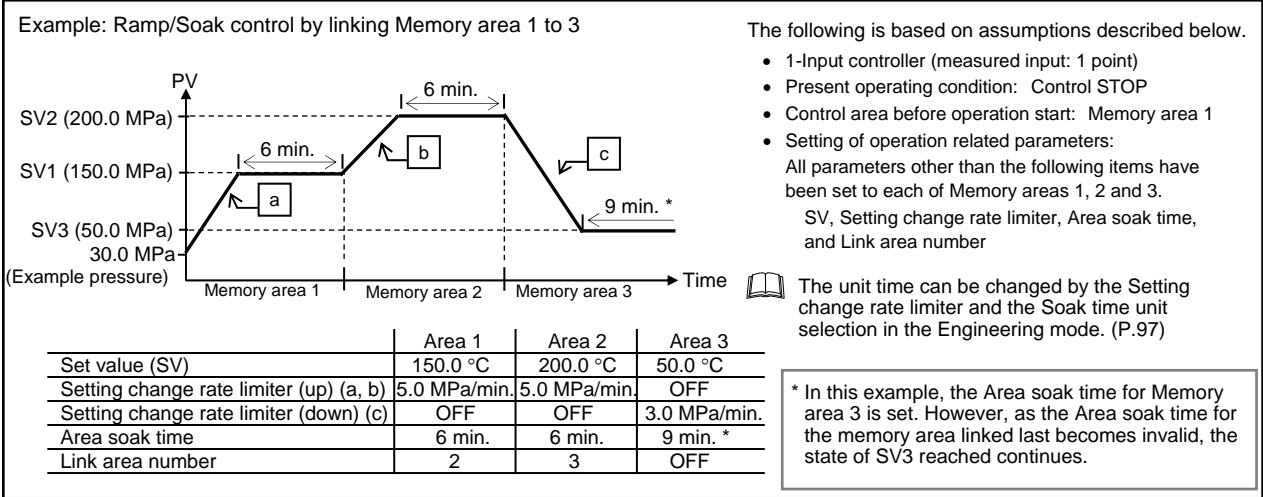

Step 1:
Set the Setting change rate limiter, Area soak time and Link area number to each of Memory area 1, 2 and 3.

1. Press the SET key several times at Parameter setting mode until Input 1_setting change rate limiter (up) setting screen is displayed.

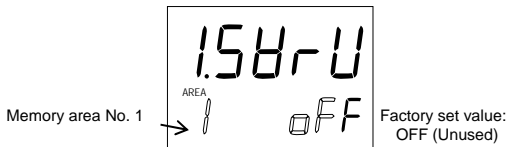

2. Press the UP key to change the number to 5.0.



3. Press the SET key to store the new value. The display goes to the next parameter. Check that this screen is set to OFF.

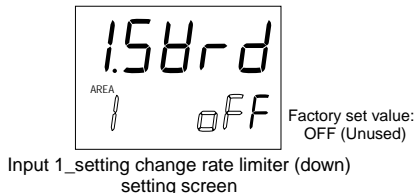

4. Press the SET key until Area soak time setting screen is displayed.

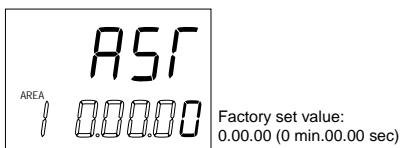

5. Press the shift key to high-light the most significant digit.

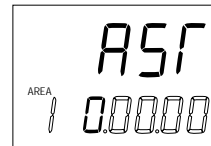

6. Press the UP key to change the number to 6.

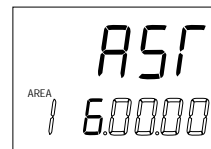

7. Press the SET key to store the new value. The display goes to the next parameter.

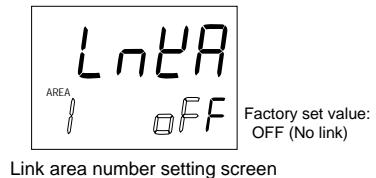

8. Press the UP key to change the number to 2.



Continued on the next page.

9. Press the SET key to store the new value. The display goes to the next parameter.



(Example: Event 1 set value setting screen)

10. Set the Memory area 2.
Press the SET key several times until Input 1_setting change rate limiter (up) setting screen is displayed.

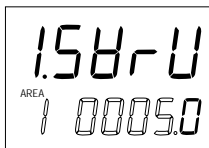

11. Press the shift key until the memory area display unit is high-lighted.

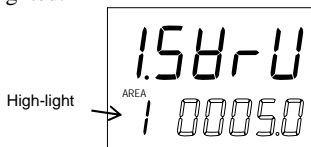

12. Press the UP key to change to 2. Area number display flashes.

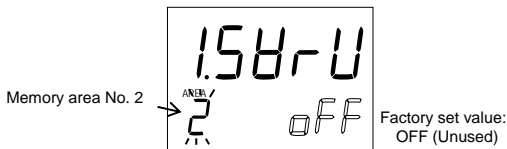

13. Press the shift key to high-light the least significant digit.

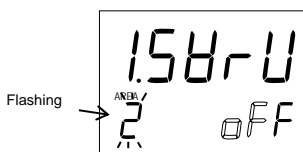

14. Press the UP key to change the number to 5.0.

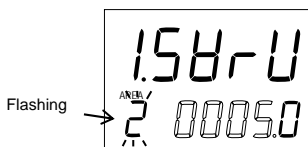

15. Press the SET key to store the new value. The display goes to the next parameter. Check that this screen is set to OFF.

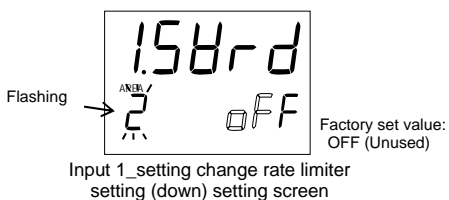

Input 1_setting change rate limiter setting (down) setting screen

16. Press the SET key until Area soak time setting screen is displayed.

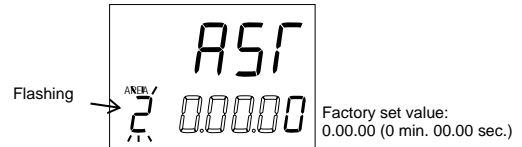

17. Press the shift key to high-light the most significant digit.

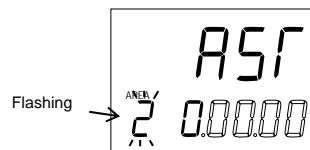

18. Press the UP key to change the number to 6.

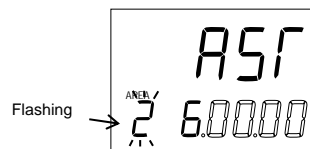

19. Press the SET key to store the new value. The display goes to the next parameter.

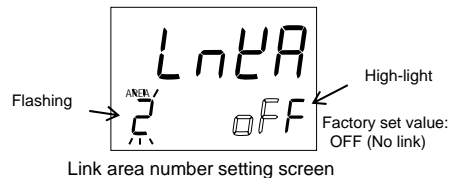

Link area number setting screen

20. Press the UP key to change the number to 3.

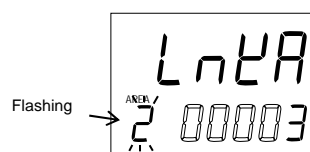

21. Press the SET key to store the new value. The display goes to the next parameter.

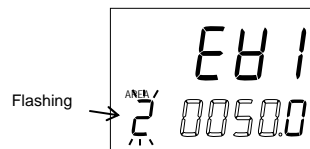

(Example: Event 1 set value setting screen)

22. Set the Memory area 3.
Press the SET key several times until Input 1_setting change rate limiter (up) setting screen is displayed.

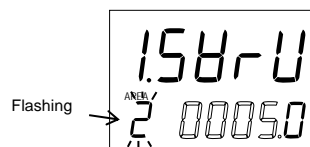

Continued on the next page.

23. Press the UP key to change the number to 3. Check that this screen is set to OFF.

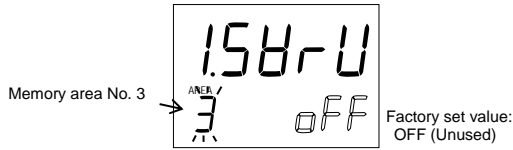

24. Press the SET key to store the new value. The display goes to the next parameter.

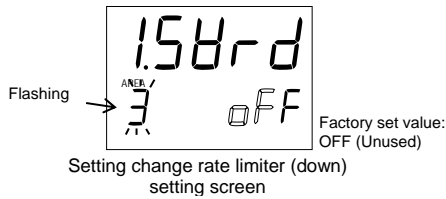

25. Press the UP key to change the number to 3.0.

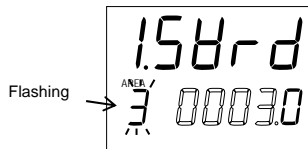

26. Press the SET key to store the new value. The display goes to the next parameter.

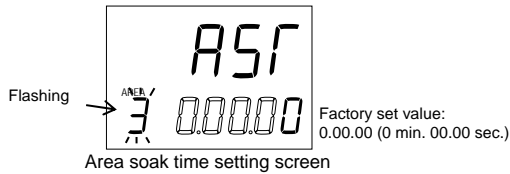

27. Press the shift key to high-light the most significant digit.

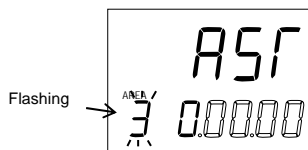

28. Press the UP key to change the number to 9.

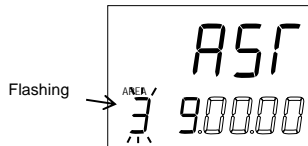

29. Press the SET key to store the new value. The display goes to the next parameter. Check that this screen is set to OFF.

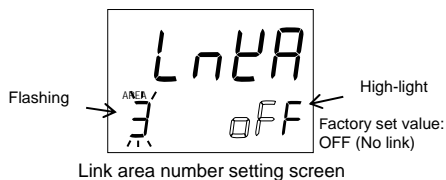

STEP 2:
Set the SV to each of Memory area 1, 2 and 3.

1. Press and hold the SET key for 2 seconds to change the mode from the Parameter Setting mode to SV setting & Monitor mode. PV1/SV1 monitor screen is displayed.

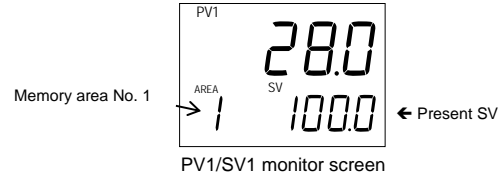

2. Press the SET key until Input 1_set value (SV1) setting screen is displayed.

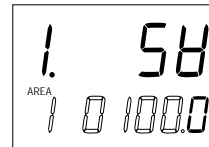

3. Press the shift key to high-light the tens digit.

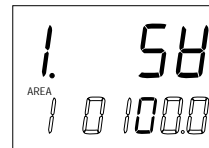

4. Press the UP key to change the number to 5.

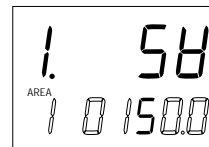

5. Press the SET key to store the new value. The display goes to the next parameter.

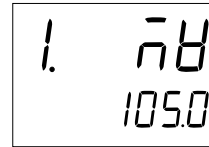

Example: Input 1_MV1 monitor screen

6. Set the Set value (SV) of Memory area 2. Press the SET key several times until Input 1_set value (SV1) setting screen is displayed.

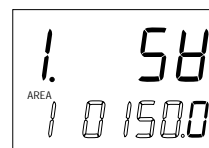

Continued on the next page.

7. Press the shift key until the memory area display unit is displayed.

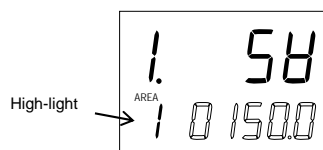

8. Press the UP key to change the number to 2. The number in AREA (Area number) display flashes.

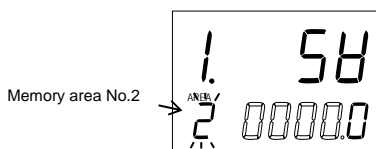

9. Press the shift key to high-light the hundreds digit.

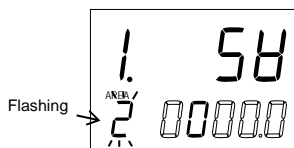

10. Press the UP key to change the number to 2.

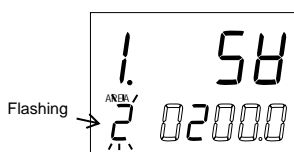

11. Press the SET key to store the new value. The display goes to the next parameter.

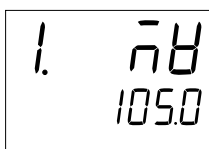

Example: Input 1_MV1 monitor screen

12. Set the Set value (SV) of Memory area 3.
Press the SET key several times until Input 1_set value (SV1) setting screen is displayed.

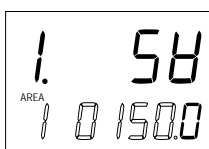

13. Press the shift key until the memory area display unit is displayed.

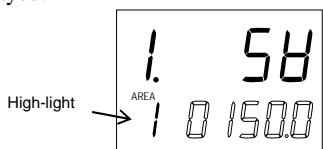

14. Press the UP key to change the number to 3. The number in AREA (Area number) display flashes.

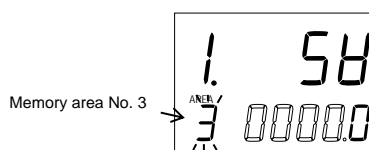

15. Press the shift key to high-light the tens digit.

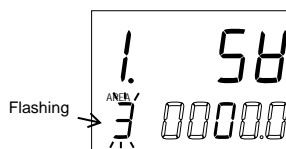

16. Press the UP key to change the number to 5.

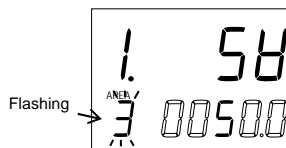

17. Press the SET key to store the new value. The display goes to the next parameter. The SV setting is finished.

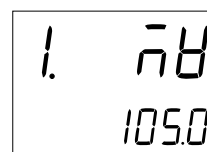

(Example: Input 1_MV1 monitor screen)

STEP 3:
Check the control area number.

Press the SET key several times at SV setting & Monitor mode until Memory area selection setting screen is displayed. Check that the memory area at the time of operation start corresponds to Memory area 1.

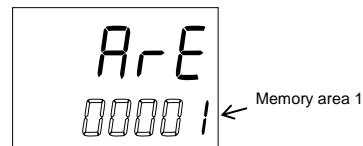

STEP 4:
Change from STOP mode to RUN mode

Operation starts if turned from STOP mode to RUN mode by pressing the RUN/STOP (R/S) transfer key.

10. ERROR DISPLAY

10.1 Over-scale and Underscale

The table below shows displays, description, control actions and solutions when the Measured value (PV) exceeds the display range.

Display	Description	Action (Output)	Solution
Measured value (PV) [Flashing]	Input error Measured value (PV) exceeds the input error determination point (high /low limit).	Action at input error: Output depending on the action at input error (high /low limit)	Check input type, input range, sensor and sensor connection.
000000 [Flashing]	Over-scale Measured value (PV) is above the display range limit high (or 99999).	Event output: Output depending on the Event action at input error	
UUUUUU [Flashing]	Underscale Measured value (PV) is below the display range limit low (or -19999).		



Prior to replacing the sensor, always turn OFF the power or change to STOP with RUN/STOP transfer. As for care which should be taken when replacing the pressure sensor, refer to the instruction manual for “Pressure sensor used.”

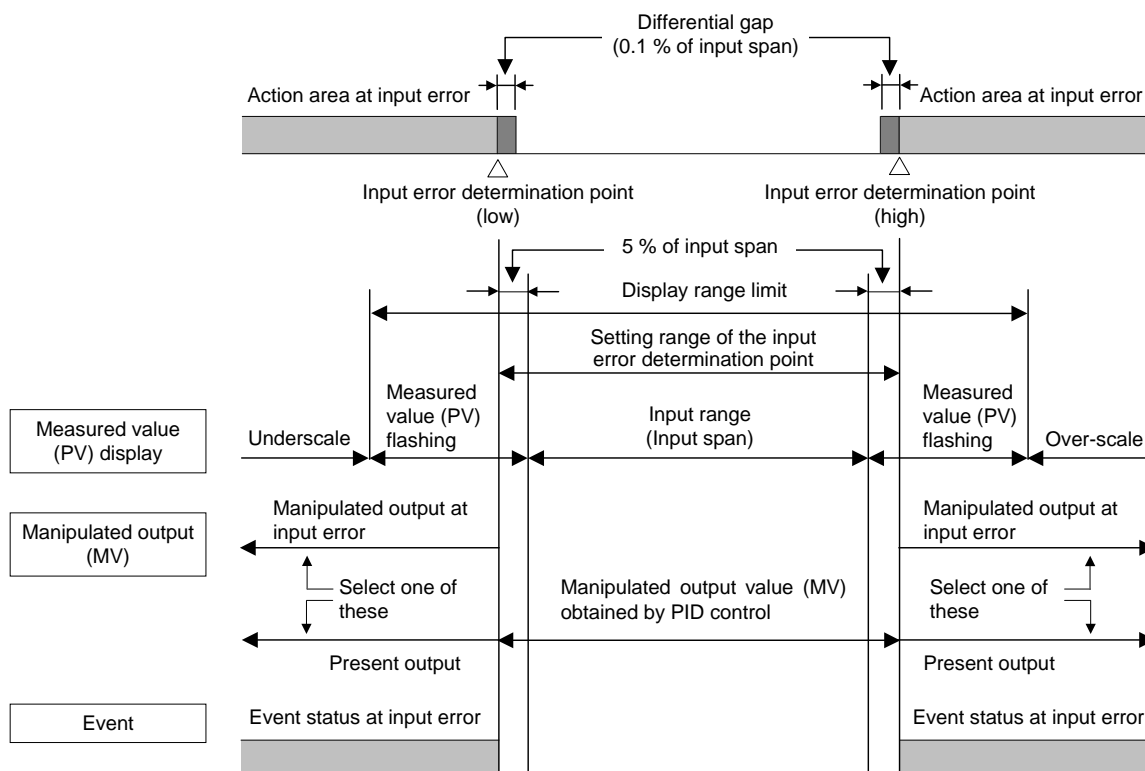

10.2 Self-diagnostic Error

Displays and description of self-diagnostics are described in the following table:

Upper display	Lower display	Description	Action	Solution
Err	1 (1)	Adjusted data error • Adjusted data range is abnormal.	Display: Error display Output: OFF Communication: Possible	Turn off the power at once. If an error occurs after the power is turned on again, please contact RKC sales office or the agent.
	2 (2)	EEPROM error • Response signal from EEPROM is abnormal. • Data write failure	Display: Error display Output: OFF Communication: Possible	
	4 (4)	A/D conversion error • Response signal from A/D converter is abnormal. • A/D conversion count value is out of the specified range.	Display: Error display Output: OFF Communication: Possible	
	8 (8)	RAM check error	Display: All display is OFF Output: OFF Communication: No response	
	16 (16)	Hardware configuration error • Hardware is abnormal except A/D conversion circuit.	Display: Error display Output: OFF Communication: Possible	
	32 (32)	Software configuration error • There is an abnormality on download data and it cannot execute.	Display: Error display Output: OFF Communication: Possible	
	128 (128)	Watchdog timer error • The part of an internal task stops the action.	Display: Error display Output: OFF Communication: Possible	
	2048 (2048)	Program busy • Could not finish an internal program in a specified time.	Display: Error display Output: OFF Communication: Possible	



When two or more errors occur simultaneously, the error code numbers are totaled and displayed as one number.

11. TROUBLESHOOTING

This section explains possible causes and solutions if any abnormality occurs in the instrument. For any inquiries or to confirm the specifications of the product, please contact RKC sales office or the agent.

If it is necessary to replace a device, always strictly observe the warnings below.

WARNING

- To prevent electric shock or instrument failure, always turn off the system power before replacing the instrument.
- To prevent electric shock or instrument failure, always turn off the power before mounting or removing the instrument.
- To prevent electric shock or instrument failure, do not turn on the power until all wiring is completed. Make sure that the wiring is correct before applying power to the instrument.
- To prevent electric shock or instrument failure, do not touch the inside of the instrument.
- All wiring must be performed by authorized personnel with electrical experience in this type of work.

CAUTION

All wiring must be completed before power is turned on to prevent electric shock, instrument failure, or incorrect action. The power must be turned off before repairing work for input break and output failure including replacement of sensor, contactor or SSR, and all wiring must be completed before power is turned on again.

11.1 Display

Problem	Possible cause	Solution
No display appears	The internal assembly is not inserted into the case correctly.	Insert the internal assembly into the case correctly.
	Power supply terminal connection not correct	Connect the terminals correctly by referring to 3.3 Wiring of Each Terminal (P. 15) .
	Power supply terminal contact defect	Retighten the terminals
	Proper power supply voltage is not being supplied.	Apply the normal power supply by referring to B. Specifications (A-27) .
Display is abnormal	Noise source is present near the instrument.	Separate the noise source from the instrument.
	Remote setting signal is input in parallel to two or more this instruments which use grounding type thermocouples.	Insert an isolator to enable isolated remote setting signal input for each instrument.

Continued on the next page.

Continued from the previous page.

Problem	Possible cause	Solution
Measured value (PV) display differs from the actual value	PV bias is set	Set the PV bias to “OFF” by referring to ■ PV bias (P. 44) . However, this is limited only to when the PV bias setting can be changed.



How to check if the input function of the controller is working correctly.

- When the controller is configured as Thermocouple input:
Short the input terminals No. 23 and No. 24 for 1-input controller type (2-input controller type: No. 23 and No. 24 [TC1], No. 20 and No. 21 [TC2]). If the controller shows a Measured value around the ambient temperature of the input terminals, the input function of the controller is working correctly.
- When the controller is configured as RTD input:
Connect a 100 Ω resistor between the input terminals No. 22 and No. 23 for 1-input controller type (2-input controller type: No. 22 and No. 23 [RTD1], No. 19 and No. 20 [RTD2]) and short the input terminals No. 23 and No. 24 (2-input controller type: No. 23 and No. 24 [RTD1], No. 20 and No. 21 [RTD2]). If the controller shows Measured value around 0 °C (32 °F), the input function of the controller is working correctly.
- When the controller is configured as Voltage/Current input:
Input a certain voltage or current from a voltage/current generator to the controller. If the controller shows the equivalent input value, the input setting and function of the controller is working correctly.

11.2 Control

Problem	Possible cause	Solution
Control is abnormal	The power supply is not correct.	Apply the normal power supply by referring to B. Specifications (A-32) .
	Sensor or input lead wires break.	Turn off the power or STOP the operation by “RUN/STOP transfer” and repair the sensor or replace it.
	Proper sensor is not used.	Use the specified sensor.
	The sensor is not wired correctly.	Conduct sensor wiring correctly by referring to 3.3 Wiring of Each Terminal (P. 15) .
	Sensor insertion depth is insufficient	Check whether sensor is inserted too loosely. If so, fully insert the sensor.
	Sensor insertion position is not appropriate	Insert the sensor at the specified location.
	Input signal wires are not separated from instrument power and/or load wires	Separate each wire.
	Noise source is present near the wiring	Separate the noise source from the wiring.
	Inappropriate PID constants	Set the correct PID constants.

Continued on the next page.

Continued from the previous page.

Problem	Possible cause	Solution
Autotuning (AT) function not activated	Requirements for performing the Autotuning (AT) function are not satisfied	Satisfy the requirements for performing the Autotuning (AT) function by referring to AT action (P. 96) .
	“2: No AT function” is selected as the AT action.	Set the AT action to “1: AT function (PI)” or “0: AT function (PID)” by referring to AT action (P. 96) . However, this is limited only to when the AT action can be changed.
Autotuning (AT) suspended	Requirements for suspending the Autotuning (AT) function are established	Identify causes for Autotuning (AT) suspension by referring to AT action (P. 96) and then remove them. Then, execute the autotuning (AT) function again.
Acceptable PID values cannot be calculated by Autotuning (AT)	The Autotuning (AT) function does not appropriately much the characteristics of the controlled object	Set PID constants manually.
	The Output change rate limiter is set	Set PID constants manually.
No output change in step	The Output change rate limiter is set	Set the Output change rate limiter to “0.0: OFF” by referring to 8.12 Control 1/Control 2 (P. 87) . However, this is limited only to when the Output change rate limiter setting can be changed.

11.3 Operation

Problem	Possible cause	Solution
Output does not become more than (or less than) a specific value	The Output limiter is set	Change the Output limiter setting by referring to 8.12 Control 1/Control 2 (P. 87) . However, this is limited only to when the Output limiter setting can be changed.
No setting change can be made by key operation	Set data is locked	Release the set data lock by referring to ■ Set lock level (P. 49) .

Continued on the next page.

Continued from the previous page.

Problem	Possible cause	Solution
Set value (SV) does not become more than (or less than) a specific value	The Setting limiter is set	Change the Setting limiter setting by referring to 8.16 Set Value 1 (SV1)/Set Value 2 (SV2) (P. 98) . However, this is limited only to when the Setting limiter setting can be changed.
Set value (SV) does not change immediately when the Set value (SV) is changed	The Setting change rate limiter is set	Set the Setting change rate limiter to "OFF" by referring to ■ Setting change rate limiter [up] (P. 38) , ■ Setting change rate limiter [down] (P. 39) .

11.4 Other

Problem	Possible cause	Solution
Event action is abnormal	Event action is different from the specification.	Change the action by referring to 8.10 Event 1/Event 2/Event 3 /Event 4 (P. 80) after the specification is confirmed.
	Event output relay contact energized/de-energized is reversed	Confirm the selection of output logic calculation by referring to 8.8 Output (P. 76) .
	Event differential gap setting is inappropriate	Set the appropriate differential gap by referring to 8.10 Event 1/Event 2/Event 3/Event 4 (P. 80) .

12. REMOVING THE INTERNAL ASSEMBLY

Removing the internal assembly from the case is rarely required. Should you remove the internal assembly without disconnecting the external wiring, take the following steps:



WARNING

- To prevent electric shock or instrument failure, only qualified personnel should be allowed to pull out the internal assembly.
- To prevent electric shock or instrument failure, always turn off the power before pulling out the internal assembly.
- To prevent injury or instrument failure, do not touch the internal printed wiring board.



Apply pressure very carefully when removing internal assembly to avoid damage to the frame.



To conform to **IEC 61010-1** requirements for protection from electric shock, the internal assembly of this instrument can only be removed with an appropriate tool.

■ Procedures

Lock (Upper: 2 places)

Recommended tool: Slotted screwdriver
Tip width: 6 mm or less

Unlock using such a slotted screwdriver.
Gently press down on handle for the upper lock and lift up for the lower lock.

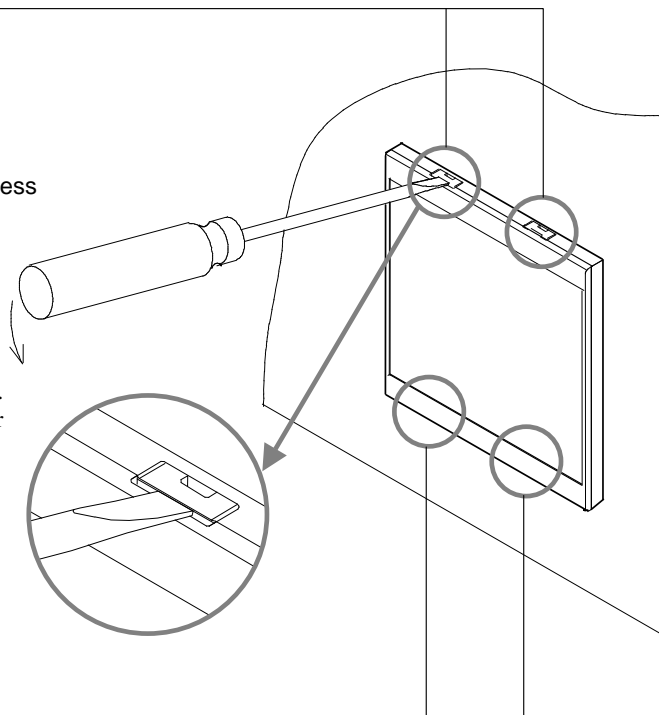

Lock (Lower: 2 places)

APPENDIX

A. Setting Data List

A-1. SV setting & Monitor mode

Name	Parameter	Data range	Factory set value	User set value	Page
Input 1_ measured value (PV1)/ set value (SV1) monitor	—	The upper section: Displays Input 1_PV1 The lower section: Displays Input 1_SV1	—		P. 30 P. 102
Input 2_ measured value (PV2)/ set value (SV2) monitor	—	The upper section: Displays Input 2_PV2 The lower section: Displays Input 2_SV2	—		P. 30 P. 103
Input 1_ measured value (PV1)/ Input 2_measured value (PV2) monitor	—	The upper section: Displays Input 1_PV1 The lower section: Displays Input 2_PV2	—		P. 30 P. 103
Input 1_set value (SV1)	1 SH (1. SV)	Input 1_setting limiter low to Input 1_setting limiter high	0.0		P. 30
Input 2_set value (SV2)	2 SH (2. SV)	Input 2_setting limiter low to Input 2_setting limiter high	0.0		P. 30
Remote input value monitor	SHr (SVr)	Input 1_setting limiter low to Input 1_setting limiter high	—		P. 30 P. 103
PV1 peak hold value monitor	1PHLd (1.PHLd)	The maximum PV1 value (peak value) of Input 1 is held and displayed.	—		P. 30 P. 103
PV1 bottom hold value monitor	1bHLd (1.bHLd)	The minimum PV1 value (bottom value) of Input 1 is held and displayed.	—		P. 30 P. 104
PV1 hold reset	1HLdr (1.HLdr)	PV1_hold value is reset when the UP and DOWN keys a simultaneously pressed.	—		P. 30 P. 105
PV2 peak hold value monitor	2PHLd (2.PHLd)	The maximum PV2 value (peak value) of Input 2 is held and displayed.	—		P. 30 P. 105
PV2 bottom hold value monitor	2bHLd (2.bHLd)	The minimum PV2 value (bottom value) of Input 2 is held and displayed.	—		P. 30 P. 105
PV2 hold reset	2HLdr (2.HLdr)	PV2_hold value is reset when the UP and DOWN keys a simultaneously pressed.	—		P. 30 P. 105
Input 1_manipulated output value (MV1) monitor	1 MV (1. MV)	Input 1_MV scaling low to Input 1_MV scaling high	—		P. 30 P. 106
Input 2_manipulated output value (MV2) monitor	2 MV (2. MV)	-5.0 to +105.0 %	—		P. 30 P. 106
Event monitor	EVr (EVM)	SV thousands digits: EV4 (LBA2) SV hundreds digits: EV3 (LBA1) SV tens digits: EV2 SV units digits: EV1	—		P. 30 P. 106

Continued on the next page.

Continued from the previous page.

Name	Parameter	Data range	Factory set value	User set value	Page
Interlock release	ILr (ILr)	<ul style="list-style-type: none"> Displays the interlock status. Interlock status is release when the UP and Down keys a simultaneously pressed. 	—		P. 30 P. 106
Memory area selection	ArE (ArE)	1 to 16	1		P. 30 P. 107
Memory area soak time monitor	APr (APT)	0 minute 00.00 second to 9 minutes 59.99 seconds or 0 hour 00 minute 00 second to 9 hours 59 minutes 59 seconds	—		P. 30 P. 107
CC-Link communication status	$CCLs$ (CCLS)	Displays the status number.	—		P. 30 P. 107

A-2. Setup setting mode

Name	Parameter	Data range	Factory set value	User set value	Page
Input 1_PV bias	$1. Pb$ (1. Pb)	–Input span to +Input span	0		P. 44
Input 1_PV digital filter	$1. dF$ (1. dF)	OFF (Unused) 0.01 to 10.00 seconds	OFF		P. 44
Input 1_PV ratio	$1. Pr$ (1. Pr)	0.500 to 1.500	1.000		P. 44
Input 1_PV low input cut-off	$1. PLC$ (1. PLC)	0.00 to 25.00 % of input span	0.00		P. 45
Input 1_proportional cycle time	$1. T$ (1. T)	0.1 to 100.0 seconds Other outputs: Voltage pulse output and Triac output	Relay contact output: 20.0 Other outputs: 2.0		P. 45
Input 2_PV bias	$2. Pb$ (2. Pb)	–Input span to +Input span	0		P. 44
Input 2_PV digital filter	$2. dF$ (2. dF)	OFF (Unused) 0.01 to 10.00 seconds	OFF		P. 44
Input 2_PV ratio	$2. Pr$ (2. Pr)	0.500 to 1.500	1.000		P. 44
Input 2_PV low input cut-off	$2. PLC$ (2. PLC)	0.00 to 25.00 % of input span	0.00		P. 45
Input 2_proportional cycle time	$2. T$ (2. T)	0.1 to 100.0 seconds Other outputs: Voltage pulse output and Triac output	Relay contact output: 20.0 Other outputs: 2.0		P. 45

Continued on the next page.

Continued from the previous page.

Name	Parameter	Data range	Factory set value	User set value	Page
Device address (Slave address)	<i>Add2</i> (Add2)	0 to 99 (RKC communication, Modbus) 0 to 63 (DeviceNet) 0 to 126 (PROFIBUS) 0 to 64 (CC-Link: 1 station occupied 1 time, 1 station occupied 4 times, 1 station occupied 8 times) 1 to 61 (CC-Link: 4 stations occupied 1 time)	0		P. 46
Communication speed	<i>bPS2</i> (bPS2)	2.4: 2400 bps 156: 156 kbps ² 4.8: 4800 bps 625: 625 kbps ² 9.6: 9600 bps 2500: 2.5 kbps ² 19.2: 19200 bps 5000: 5 Mbps ² 38.4: 38400 bps 10000: 10 Mbps ² 125: 125 kbps ¹ 250: 250 kbps ¹ 500: 500 kbps ¹ ¹ DeviceNet only ² CC-Link only	RKC communication, Modbus: 9.6 DeviceNet: 125 CC-Link: 156		P. 46
Data bit configuration	<i>bit2</i> (bIT2)	Refer to Data bit configuration on the next page.	8n1		P. 46
Interval time	<i>InT2</i> (InT2)	0 to 250 ms	10		P. 47
Infrared communication address	<i>Add3</i> (Add3)	0 to 99	0		P. 47
Infrared communication speed	<i>bPS3</i> (bPS3)	9.6: 9600 bps 19.2: 19200 bps	19.2		P. 47
Auto-zero (Input 1)	<i>AZE_r</i> (AZE _r)	Adjust the zero point of the Measured value (PV1) on the Input 1 side. Relevant pressure sensors: CZ-100P, CZ-200P	—		P. 48
Auto calibration (Input 1)	<i>ACAL</i> (ACAL)	Adjust the full scale point of the Measured value (PV1) on the Input 1 side.	—		P. 49
Set lock level	<i>LCK</i> (LCK)	Refer to Set lock level list on the next page.	00000		P. 49

Continued on the next page.

Continued from the previous page.

Data bit configuration

Set value	Data bit	Parity bit	Stop bit
<i>B_n1</i> (8n1)	8	None	1
<i>B_n2</i> (8n2)	8	None	2
<i>BE1</i> (8E1)	8	Odd	1
<i>BE2</i> (8E2)	8	Even	2
<i>Bo1</i> (8o1)	8	Odd	1
<i>Bo2</i> (8o2)	8	Even	2
<i>7_n1</i> (7n1)	7	None	1
<i>7_n2</i> (7n2)	7	None	2
<i>7E1</i> (7E1)	7	Odd	1
<i>7E2</i> (7E2)	7	Odd	2
<i>7o1</i> (7o1)	7	Even	1
<i>7o2</i> (7o2)	7	Even	2

(7n1 to 7o2: Invalid for Modbus)

Set lock level list

Set value	Parameters which can be changed
00000	All parameters [Factory set value]
00001	SV, EV1 to EV4, Memory area selection, Parameters in F10 to F91
00010	All parameters except for EV1 to EV4
00011	SV
00100	All parameters except for SV
00101	EV1 to EV4
00110	All parameters except for SV and EV1 to EV4
00111	No parameter (All Locked)

A-3. Parameter setting mode

Name	Parameter	Data range	Factory set value	User set value	Page
Event 1 set value	<i>EV1</i> (EV1)	Deviation: –Input span to +Input span Process/SV: Input scale low to Input scale high	50.0		P. 35
Event 2 set value	<i>EV2</i> (EV2)	Deviation: –Input span to +Input span Process/SV: Input scale low to Input scale high	50.0		P. 35
Event 3 set value	<i>EV3</i> (EV3)	Deviation: –Input span to +Input span Process/SV: Input scale low to Input scale high	50.0		P. 35
Control loop break alarm 1 (LBA1) time	<i>LbA1</i> (LbA1)	OFF (Unused) 1 to 7200 seconds	480		P. 35
LBA1 deadband	<i>Lbd1</i> (Lbd1)	0.0 to Input span (Varies with the setting of the Decimal point position)	0.0		P. 36
Event 4 set value	<i>EV4</i> (EV4)	Deviation: –Input span to +Input span Process/SV: Input scale low to Input scale high	50.0		P. 35
Control loop break alarm 2 (LBA2) time	<i>LbA2</i> (LbA2)	OFF (Unused) 1 to 7200 seconds	480		P. 35
LBA2 deadband	<i>Lbd2</i> (Lbd2)	0.0 to Input span (Varies with the setting of the Decimal point position)	0.0		P. 36
Input 1_proportional band	<i>I P</i> (I. P)	0.0 to 1000.0 % of input span 0.0: ON/OFF action	100.0		P. 37
Input 1_integral time	<i>I I</i> (I. I)	OFF (PD action) 1 to 3600 seconds, 0.1 to 3600.0 seconds, or 0.01 to 360.00 seconds (Varies with the setting of the Integral/Derivative time decimal point position selection)	5.00		P. 37
Input 1_derivative time	<i>I d</i> (I. d)	OFF (PI action) 1 to 3600 seconds, 0.1 to 3600.0 seconds, or 0.01 to 360.00 seconds (Varies with the setting of the Integral/Derivative time decimal point position selection)	OFF		P. 37

Continued on the next page.

Continued from the previous page.

Name	Parameter	Data range	Factory set value	User set value	Page
Input 1_control response parameter	1. rPt (1. rPt)	0: Slow 1: Medium 2: Fast	0		P. 38
Input 2_proportional band	2. P (2. P)	TC/RTD inputs: 0 (0.0, 0.00) to Input span (Unit: °C [°F]) (Varies with the setting of the Decimal point position) Voltage (V)/Current (I) inputs: 0.0 to 1000.0 % of input span 0 (0.0, 0.00): ON/OFF action	30.0		P. 37
Input 2_integral time	2. I (2. I)	OFF (PD action) 1 to 3600 seconds, 0.1 to 3600.0 seconds, or 0.01 to 360.00 seconds (Varies with the setting of the Integral/Derivative time decimal point position selection)	240.00		P. 37
Input 2_derivative time	2. d (2. d)	OFF (PI action) 1 to 3600 seconds, 0.1 to 3600.0 seconds, or 0.01 to 360.00 seconds (Varies with the setting of the Integral/Derivative time decimal point position selection)	60.00		P. 37
Input 2_control response parameter	2. rPt (2. rPt)	0: Slow 1: Medium 2: Fast	0		P. 38
Input 1_setting change rate limiter (up)	1SVrU (1.SVrU)	OFF (Unused) 0.1 to Input span/unit time *	OFF		P. 38
Input 1_setting change rate limiter (down)	1SVrd (1.SVrd)	(Varies with the setting of the Decimal point position)	OFF		P. 39
Input 2_setting change rate limiter (up)	2SVrU (2. SVrU)		OFF		P. 38
Input 2_setting change rate limiter (down)	2SVrd (2.SVrd)	* Unit time: 60 seconds (factory set value)	OFF		P. 39
Area soak time	AST (AST)	0 minute 00.00 second to 9 minutes 59.99 seconds or 0 hour 00 minute 00 second to 9 hours 59 minutes 59 seconds	0.00.00		P. 40
Link area number	LnKA (LnKA)	OFF (No link) 1 to 16	OFF		P. 41

A-4. Engineering mode (F10 to F91)



In Engineering mode, the function blocks (F45, F46 and F55) and setting items which do not exist in the HA430/930 are also displayed. For these function blocks and setting items, use their factory set values with these values left intact.

■ Function block F10: Screen configuration

Name	Parameter	Data range	Factory set value	User set value	Page
STOP display selection	\overline{SPCH} (SPCH)	0: Displays on the Measured value (PV1/PV2) unit 1: Displays on the Set value (SV) unit	0		P. 63
Bar graph display selection	\overline{dE} (dE)	0: No display 1: Input 1_manipulated output value (MV) 2: Input 1_measured value (PV) 3: Input 1_set value (SV) 4: Input 1_deviation value 5: Unused (Not available) 6: Input 2_manipulated output value (MV) 7: Input 2_measured value (PV) 8: Input 2_set value (SV) 9: Input 2_deviation value	0		P. 63
Bar graph resolution setting	\overline{dEUF} (dEUT)	1 to 100 digit/dot	100		P. 64
Decimal point position of MV scaling	\overline{MVdP} (MVdP)	0: No decimal place 1: One decimal place 2: Two decimal places 3: Three decimal places 4: Four decimal places	1		P. 64
Input 1_MV scaling high	\overline{MVHS} (MVHS)	-1999.9 to +9999.9	100.0		P. 64
Input 1_MV scaling low	\overline{MVLS} (MVLS)	-1999.9 to +9999.9	0.0		P. 65

■ Function block F11: Direct key

Name	Parameter	Data range	Factory set value	User set value	Page
Auto/Manual transfer key operation selection (A/M)	$\overline{Fn1}$ (Fn1)	0: Unused 1: Auto/Manual transfer for Input 1 2: Auto/Manual transfer for Input 2 3: Auto/Manual transfer for Input 1 and Input 2	3		P. 65
Remote/Local transfer key operation selection (R/L)	$\overline{Fn2}$ (Fn2)	0: Unused 1: Remote/Local transfer	1		P. 65
RUN/STOP transfer key operation selection (R/S)	$\overline{Fn3}$ (Fn3)	0: Unused 1: RUN/STOP transfer	1		P. 65

■ Function block F21: Input 1

Name	Parameter	Data range	Factory set value	User set value	Page
Input 1_input type selection	<i>I I nP</i> (1. InP)	Voltage (V)/Current (I) inputs -19999 to +99999 14: 0 to 20 mA DC 24: ± 100 mV DC 15: 4 to 20 mA DC 25: ± 10 mV DC 16: 0 to 10 V DC 26: ± 10 V DC 17: 0 to 5 V DC 27: ± 5 V DC 18: 1 to 5 V DC 28: ± 1 V DC 19: 0 to 1 V DC 20: 0 to 100 mV DC 21: 0 to 10 mV DC Pressure sensor input 0.0 to 250.0 MPa 29: Resin pressure sensor Relevant pressure sensors: CZ-100P, CZ-200P 22, 23: Unused (Not available)	Based on model code. When not specifying: Pressure sensor input		P. 66
Input 1_display unit selection	<i>UnI T</i> (1.UnIT)	2: MPa 3: bar 4: kgf/cm ² 5: psi The display unit selection becomes invalidated when the Voltage (V)/ Current (I) input is selected as input type.	Pressure sensor input: 2 V/I: 0		P. 67
Gain setting	<i>GAI n</i> (GAI n)	0.500 to 4.000 mV/V Relevant pressure sensors: CZ-100P, CZ-200P	CZ-100P, CZ-200P: 1.500		P. 67
Linearize type selection	<i>LI nS</i> (LI nS)	0: Unused 1 to 20: Used * Relevant pressure sensors: CZ-100P, CZ-200P	0		P. 68
Shunt resistance output value	<i>SHnT</i> (SHnT)	40.0 to 100.0 %	80.0		P. 68

* Linearizing type:

Set value	1	2	3	4	5	6	7	8	9	10	11	12	13	14	15	16	17	18	19	20
Symbol	C	D	E	F	G	H	J	K	L	M	P	Q	R	S	T	U	V	W	X	Y

Continued on the next page.

Continued from the previous page.

Name	Parameter	Data range	Factory set value	User set value	Page
Input 1_decimal point position	<i>1PGdP</i> (1.PGdP)	0: No decimal place 1: One decimal place 2: Two decimal places 3: Three decimal places 4: Four decimal places Less than 1 MPa (Rated pressure): Decimal point position 0 to 4 Less than 10 MPa (Rated pressure): Decimal point position 0 to 3 Less than 100 MPa (Rated pressure): Decimal point position 0 to 2 100 MPa or more (Rated pressure): Decimal point position 0 or 1 Voltage (V)/Current (I) inputs: Decimal point position 0 to 4	1		P. 69
Input 1_input scale high	<i>1PGSH</i> (1.PGSH)	Pressure sensor input: Input scale low to Maximum value of the selected input range Voltage (V)/Current (I) inputs: -19999 to +99999 (Varies with the setting of the Decimal point position)	Pressure sensor input: 50.0 V/I: 100.0		P. 69
Input 1_input scale low	<i>1PGSL</i> (1.PGSL)	Pressure sensor input: Minimum value of the selected input range to Input scale high Voltage (V)/Current (I) inputs: -19999 to +99999 (Varies with the setting of the Decimal point position)	Pressure sensor input: 0.0 V/I: 0.0		P. 70
Input 1_input error determination point (high)	<i>1PoH</i> (1. PoV)	Input scale low – (5 % of input span) to Input scale high + (5 % of input span)	Pressure sensor input: Input scale high + (5 % of input span) V/I: 105.0		P. 70
Input 1_input error determination point (low)	<i>1PUl</i> (1. PUn)		Pressure sensor input: Input scale low – (5 % of input span) V/I: -5.0		P. 71
Input 1_burnout direction	<i>1boS</i> (1. boS)	0: Upscale 1: Downscale	0		P. 71
Input 1_square root extraction selection	<i>1SQr</i> (1. SQr)	0: Unused 1: Used	0		P. 72
Input 1_PV1 hold function	<i>1HLdS</i> (1.HLdS)	0: Unused 1: Used	0		P. 72
Power supply frequency selection	<i>PFrQ</i> (PFrQ)	0: 50 Hz 1: 60 Hz	0		P. 72

■ Function block F22: Input 2

Name	Parameter	Data range	Factory set value	User set value	Page
Input 2_input type selection	$\overline{2} \text{ InP}$ (2. InP)	TC input 0: K -200 to +1372 °C -328.0 to +2501.6 °F 1: J -200 to +1200 °C -328.0 to +2192.0 °F 2: R -50 to +1768 °C -58.0 to +3214.4 °F 3: S -50 to +1768 °C -58.0 to +3214.4 °F 4: B 0 to 1800 °C 32.0 to 3272.0 °F 5: E -200 to +1000 °C -328.0 to +1832.0 °F 6: N 0 to 1300 °C 32.0 to 2372.0 °F 7: T -200 to +400 °C -328.0 to +752.0 °F 8: W5Re/W26Re 0 to 2300 °C 32.0 to 4172.0 °F 9: PLII 0 to 1390 °C 32.0 to 2534.0 °F RTD input (3-wire system) 12: Pt100 -200 to +850 °C -328.0 to +1562.0 °F 13: JPt100 -200 to +600 °C -328.0 to +1112.0 °F Voltage (V)/Current (I) inputs -19999 to +99999 14: 0 to 20 mA DC 24: ± 100 mV DC 15: 4 to 20 mA DC 25: ± 10 mV DC 16: 0 to 10 V DC 26: ± 10 V DC 17: 0 to 5 V DC 27: ± 5 V DC 18: 1 to 5 V DC 28: ± 1 V DC 19: 0 to 1 V DC 20: 0 to 100 mV DC 21: 0 to 10 mV DC 22, 23: Unused (Not available)	Based on model code. When not specifying: Type K		P. 66
Input 2_display unit selection	$\overline{2} \text{ UnIT}$ (2.UnIT)	0: °C 1: °F The display unit selection becomes invalidated when the Voltage (V)/Current (I) input is selected as input type.	0		P. 67

Continued on the next page.

Continued from the previous page.

Name	Parameter	Data range	Factory set value	User set value	Page
Input 2_decimal point position	<i>2PGdP</i> (2.PGdP)	0: No decimal place 1: One decimal place 2: Two decimal places 3: Three decimal places 4: Four decimal places	1		P. 69
Input 2_input scale high	<i>2PGSH</i> (2.PGSH)	TC/RTD inputs: Input scale low to Maximum value of the selected input range Voltage (V)/Current (I) inputs: -19999 to +99999 (Varies with the setting of the Decimal point position)	TC/RTD: Maximum value of the selected input range V/I: 100.0		P. 69
Input 2_input scale low	<i>2PGSL</i> (2.PGSL)	TC/RTD inputs: Minimum value of the selected input range to Input scale high Voltage (V)/Current (I) inputs: -19999 to +99999 (Varies with the setting of the Decimal point position)	TC/RTD: Minimum value of the selected input range V/I: 0.0		P. 70
Input 2_input error determination point (high)	<i>2.PoH</i> (2. PoV)	Input scale low – (5 % of input span) to Input scale high + (5 % of input span)	TC/RTD: Input scale high + (5 % of input span) V/I: 105.0		P. 70
Input 2_input error determination point (low)	<i>2.PUn</i> (2. PUn)		TC/RTD: Input scale low – (5 % of input span) V/I: -5.0		P. 71
Input 2_burnout direction	<i>2.boS</i> (2. boS)	0: Upscale 1: Downscale	0		P. 71
Input 2_square root extraction selection	<i>2.SQr</i> (2. SQr)	0: Unused 1: Used	0		P. 72
Input 2_PV2 hold function	<i>2.HLdS</i> (2.HLdS)	0: Unused 1: Used	0		P. 72

■ Function block F23: Event input

Name	Parameter	Data range	Factory set value	User set value	Page
Event input logic selection	<i>di SL</i> (dISL)	0 to 15 (Refer to the following table.)	1		P. 73

Event input logic selection

Set value	DI 1	DI 2	DI 3	DI 4	DI 5
	Terminal No. 30-31	Terminal No. 30-32	Terminal No. 30-33	Terminal No. 30-34	Terminal No. 35-36
0	Unused (No function assignment)				
1	Memory area number selection (1 to 16)				Memory area set
2	Memory area number selection (1 to 16)				Memory area set
3	Memory area number selection (1 to 16)				Memory area set
4	Memory area number selection (1 to 8)			Memory area set	RUN/STOP transfer
5	Memory area number selection (1 to 8)			Memory area set	Remote/Local transfer
6	Memory area number selection (1 to 8)			Memory area set	Auto/Manual transfer
7	Memory area number selection (1 to 8)			Memory area set	Hold reset
8	Memory area number selection (1 to 8)			Memory area set	Interlock release
9	Memory area number selection (1 to 4)		Memory area set	RUN/STOP transfer	Auto/Manual transfer
10	Memory area number selection (1 to 4)		Memory area set	RUN/STOP transfer	Remote/Local transfer
11	Memory area number selection (1 to 4)		Memory area set	Remote/Local transfer	Auto/Manual transfer
12	Memory area number selection (1 to 4)		Memory area set	Hold reset	Interlock release
13	Auto/Manual transfer	RUN/STOP transfer	Remote/Local transfer	Hold reset	Interlock release
14	Auto/Manual transfer	Input 1_ manual output down (motor RPM down) ¹	Input 1_ manual output up (motor RPM up) ²	Input 1_manual output 0 % reset (motor RPM reset) ³	RUN/STOP transfer
15	Auto/Manual transfer	Input 2_ manual output down (motor RPM down) ¹	Input 2_ manual output up (motor RPM up) ²	Input 2_manual output 0 % reset (motor RPM reset) ³	RUN/STOP transfer

¹ Decreases manipulated output value (motor RPM) under Manual control with contacts closed.

² Increases manipulated output value (motor RPM) under Manual control with contacts closed.

³ Manipulated output value (motor RPM) is reset to 0 % based on the edge discrimination of “open” to “closed.”



With Event input, terminals 30 to 36 are allocated to Event input. Event input must be specified when ordering.

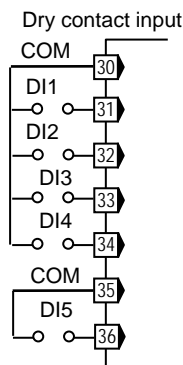

Contact input from external devices or equipment should be dry contact input. If it is not dry contact input, the input should have meet the specifications below.

Contact specifications: At OFF (contact open): 500 kΩ or more
At ON (contact closed) 10 Ω or less

■ Function block F30: Output

Name	Parameter	Data range	Factory set value	User set value	Page
Output logic selection	LOGC (LoGC)	1 to 11 (Refer to the following table.) 1, 2, 9 and 10: Unused	1-input: 3 2-input: 5		P. 76
Output 1 timer setting	oTT1 (oTT1)	0.0 to 600.0 seconds	0.0		P. 77
Output 2 timer setting	oTT2 (oTT2)		0.0		P. 77
Output 3 timer setting	oTT3 (oTT3)		0.0		P. 77
Output 4 timer setting	oTT4 (oTT4)		0.0		P. 77
Output 5 timer setting	oTT5 (oTT5)		0.0		P. 77
Alarm lamp lighting condition setting	ALC1 (ALC1)		SV ten thousand digits: "0" Fixed SV thousands digits: 0 or 1 (Event 4) SV hundreds digits: 0 or 1 (Event 3) SV tens digits: 0 or 1 (Event 2) SV units digits: 0 or 1 (Event 1)	01111 (0: ALM lamp isn't lit 1: ALM lamp is lit)	
Unused *	ALC2 (ALC2)	—	00011	—	—
Interlock function	oTIL (oTIL)	SV ten thousands digits: 0 or 1 (OUT5) SV thousands digits: 0 or 1 (OUT4) SV hundreds digits: 0 or 1 (OUT3) SV tens digits: 0 or 1 (OUT2) SV units digits: 0 or 1 (OUT1)	00000 (0: Unused 1: Used)		P. 78

* This item is not used for the HA430/930.

Output logic selection

Set value	OUT1	OUT2	OUT3	OUT4	OUT5
1	This set value is not used for the HA430/930.				
2	This set value is not used for the HA430/930.				
3	MV1	EV3 or EV4 (Energized)	EV2 (Energized)	EV1 (Energized)	FAIL (De-energized)
4	MV1	EV3 or EV4 (De-energized)	EV2 (De-energized)	EV1 (De-energized)	FAIL (De-energized)
5	MV1	MV2	EV4 (Energized)	EV3 (Energized)	EV1 or EV2 (Energized)
6	MV1	MV2	EV4 (De-energized)	EV3 (De-energized)	EV1 or EV2 (De-energized)
7	MV1	MV2	EV3 or EV4 (Energized)	EV2 (Energized)	EV1 (Energized)
8	MV1	MV2	EV3 or 4 (De-energized)	EV2 (De-energized)	EV1 (De-energized)
9	This set value is not used for the HA430/930.				
10	This set value is not used for the HA430/930.				
11	MV1	EV4 (Energized)	EV3 (Energized)	EV2 (Energized)	EV1 (Energized)

■ Function block F31: Transmission output 1

Name	Parameter	Data range	Factory set value	User set value	Page
Transmission output 1_ type selection	<i>Ao1</i> (Ao1)	-----: None 1. PV: Input 1_ measured value (PV) 1. SV: Input 1_set value (SV) 1.dEV: Input 1_deviation value 1. MV: Input 1_manipulated output value (MV) 2. PV: Input 2_ measured value (PV) 2. SV: Input 2_set value (SV) 2.dEV: Input 2_deviation value 2. MV: Input 2_manipulated output value (MV) PoS: Unused (Not available)	-----: None		P. 79
Transmission output 1_ scale high	<i>AHS1</i> (AHS1)	Measured value (PV) and Set value (SV): Input scale low to Input scale high Manipulated output value (MV): -5.0 to +105.0 %	PV/SV: Input scale high MV: 100.0 Deviation: +Input span		P. 79
Transmission output 1_ scale low	<i>ALS1</i> (ALS1)	Deviation: -Input span to +Input span	PV/SV: Input scale low MV: 0.0 Deviation: -Input span		P. 79

■ Function block F32: Transmission output 2

Name	Parameter	Data range	Factory set value	User set value	Page
Transmission output 2_ type selection	<i>Ao2</i> (Ao2)	-----: None 1. PV: Input 1_ measured value (PV) 1. SV: Input 1_set value (SV) 1.dEV: Input 1_deviation value 1. MV: Input 1_manipulated output value (MV) 2. PV: Input 2_ measured value (PV) 2. SV: Input 2_set value (SV) 2.dEV: Input 2_deviation value 2. MV: Input 2_manipulated output value (MV) PoS: Unused (Not available)	-----: None		P. 79
Transmission output 2_ scale high	<i>AHS2</i> (AHS2)	Measured value (PV) and Set value (SV): Input scale low to Input scale high Manipulated output value (MV): -5.0 to +105.0 %	PV/SV: Input scale high MV: 100.0 Deviation: +Input span		P. 79
Transmission output 2_ scale low	<i>ALS2</i> (ALS2)	Deviation: -Input span to +Input span	PV/SV: Input scale low MV: 0.0 Deviation: -Input span		P. 79

■ Function block F33: Transmission output 3

Name	Parameter	Data range	Factory set value	User set value	Page
Transmission output 3_ type selection	<i>Ao3</i> (Ao3)	-----: None 1. PV: Input 1_ measured value (PV) 1. SV: Input 1_set value (SV) 1.dEV: Input 1_deviation value 1. MV: Input 1_manipulated output value (MV) 2. PV: Input 2_ measured value (PV) 2. SV: Input 2_set value (SV) 2.dEV: Input 2_deviation value 2. MV: Input 2_manipulated output value (MV) PoS: Unused (Not available)	-----: None		P. 79
Transmission output 3_ scale high	<i>AHS3</i> (AHS3)	Measured value (PV) and Set value (SV): Input scale low to Input scale high Manipulated output value (MV): -5.0 to +105.0 %	PV/SV: Input scale high MV: 100.0 Deviation: +Input span		P. 79
Transmission output 3_ scale low	<i>ALS3</i> (ALS3)	Deviation: -Input span to +Input span	PV/SV: Input scale low MV: 0.0 Deviation: -Input span		P. 79

■ Function block F41: Event 1

Name	Parameter	Data range	Factory set value	User set value	Page
Event 1 type selection	<i>ES1</i> (ES1)	0: None 1: Deviation high 2: Deviation low 3: Deviation high/low 4: Band 5: Process high 6: Process low 7: SV high 8: SV low	0		P. 80
Event 1 hold action	<i>EHo1</i> (EHo1)	0: OFF 1: ON 2: Re-hold action ON	0		P. 82
Event 1 differential gap	<i>EH1</i> (EH1)	0 to Input span (Varies with the setting of the Decimal point position)	Pressure sensor input: 2.0 MPa TC/RTD: 2.0 °C [°F] V/I: 0.2 % of input span		P. 83
Event 1 action at input error	<i>EEo1</i> (EEo1)	0: Normal processing 1: Turn the event output ON	0		P. 84
Event 1 assignment	<i>EVA1</i> (EVA1)	1: For Input 1 2: For Input 2	1		P. 84

■ Function block F42: Event 2

Name	Parameter	Data range	Factory set value	User set value	Page
Event 2 type selection	<i>ES2</i> (ES2)	0: None 1: Deviation high 2: Deviation low 3: Deviation high/low 4: Band 5: Process high 6: Process low 7: SV high 8: SV low	0		P. 80
Event 2 hold action	<i>EHo2</i> (EHo2)	0: OFF 1: ON 2: Re-hold action ON	0		P. 82
Event 2 differential gap	<i>EH2</i> (EH2)	0 to Input span (Varies with the setting of the Decimal point position)	Pressure sensor input: 2.0 MPa TC/RTD: 2.0 °C [°F] V/I: 0.2 % of input span		P. 83

Continued on the next page.

Continued from the previous page.

Name	Parameter	Data range	Factory set value	User set value	Page
Event 2 action at input error	<i>EEo2</i> (EEo2)	0: Normal processing 1: Turn the event output ON	0		P. 84
Event 2 assignment	<i>EVA2</i> (EVA2)	1: For Input 1 2: For Input 2	1		P. 84

■ Function block F43: Event 3

Name	Parameter	Data range	Factory set value	User set value	Page
Event 3 type selection	<i>ES3</i> (ES3)	0: None 1: Deviation high 2: Deviation low 3: Deviation high/low 4: Band 5: Process high 6: Process low 7: SV high 8: SV low 9: Control loop break (LBA)	0		P. 80
Event 3 hold action	<i>EHo3</i> (EHo3)	0: OFF 1: ON 2: Re-hold action ON	0		P. 82
Event 3 differential gap	<i>EH3</i> (EH3)	0 to Input span (Varies with the setting of the Decimal point position)	Pressure sensor input: 2.0 MPa TC/RTD: 2.0 °C [°F] V/I: 0.2 % of input span		P. 83
Event 3 action at input error	<i>EEo3</i> (EEo3)	0: Normal processing 1: Turn the event output ON	0		P. 84
Event 3 assignment	<i>EVA3</i> (EVA3)	1: For Input 1 2: For Input 2	1		P. 84

■ Function block F44: Event 4

Name	Parameter	Data range	Factory set value	User set value	Page
Event 4 type selection	$ES4$ (ES4)	0: None 1: Deviation high 2: Deviation low 3: Deviation high/low 4: Band 5: Process high 6: Process low 7: SV high 8: SV low 9: Control loop break (LBA)	0		P. 80
Event 4 hold action	$EHo4$ (EHo4)	0: OFF 1: ON 2: Re-hold action ON	0		P. 82
Event 4 differential gap	$EH4$ (EH4)	0 to Input span (Varies with the setting of the Decimal point position)	Pressure sensor input: 2.0 MPa TC/RTD: 2.0 °C [°F] V/I: 0.2 % of input span		P. 83
Event 4 action at input error	$EEo4$ (EEo4)	0: Normal processing 1: Turn the event output ON	0		P. 84
Event 4 assignment	$EVA4$ (EVA4)	1: For Input 1 2: For Input 2	1		P. 84

■ Function block F50: Control

Name	Parameter	Data range	Factory set value	User set value	Page
Hot/Cold start selection	Pd (Pd)	Power failure less than 3 seconds: 0: Hot 1 5: Cold 1: Hot 1 6: Hot 1 2: Hot 1 7: Hot 2 3: Hot 2 8: Stop 4: Hot 2 Power failure 3 seconds or more: 0: Hot 1 5: Cold 1: Hot 2 6: Stop 2: Cold 7: Stop 3: Hot 2 8: Stop 4: Cold	5		P. 85
Input 2_use selection	CAn (CAN)	0: Single loop control 1: Remote input	0		P. 85
Unused *	CAr (CAr)	—	1.0000	—	—
Unused *	CAb (CAb)	—	0.0	—	—
SV tracking	TrK (TrK)	0: Unused 1: Used	1		P. 86

* These items are not used for the HA430/930.

■ Function block F51: Control 1

Name	Parameter	Data range	Factory set value	User set value	Page
Input 1_control action type selection	<i>l oS</i> (1. oS)	0: Direct action 1: Reverse action	1		P. 87
Input 1_integral/derivative time decimal point position selection	<i>lI ddP</i> (1.I ddP)	0: No decimal place 1: One decimal place 2: Two decimal places	2		P. 87
Input 1_derivative gain	<i>l dGA</i> (1. dGA)	0.1 to 10.0	6.0		P. 87
Input 1_ON/OFF action differential gap (upper)	<i>l oHH</i> (1. oHH)	0 to Input span (Varies with the setting of the Decimal point position)	Pressure sensor input: 1.0 MPa V/I: 0.1 % of input span		P. 88
Input 1_ON/OFF action differential gap (lower)	<i>l oHL</i> (1. oHL)				P. 88
Input 1_action at input error (high)	<i>lAoBE</i> (1.AoBE)	0: Normal control 1: Manipulated output value at input error	0		P. 89
Input 1_action at input error (low)	<i>lAUeE</i> (1.AUeE)		0		P. 89
Input 1_manipulated output value at input error	<i>l PSn</i> (1. PSM)	-5.0 to +105.0 %	-5.0		P. 90
Input 1_manipulated output value when transferred to Auto from Manual	<i>l PSn'</i> (1. PSM')	-5.0 to +105.0 %	—		P. 90
Input 1_output change rate limiter (up)	<i>l orU</i> (1. orU)	0.0 to 1000.0 %/second of manipulated output (0.0: Unused)	0.0		P. 90
Input 1_output change rate limiter (down)	<i>l ord</i> (1. ord)		0.0		P. 91
Input 1_output limiter high	<i>l oLH</i> (1. oLH)	Input 1_output limiter low to 105.0 %	105.0		P. 92
Input 1_output limiter low	<i>l oLL</i> (1. oLL)	-5.0 % to Input 1_output limiter high	-5.0		P. 92
Unused *	<i>l PFF</i> (1. PFF)	—	0 or 1	—	—
Unused *	<i>l PFFS</i> (1.PFFS)	—	1.00	—	—
Input 1_MV transfer function	<i>l MVTS</i> (1.MVTS)	0: Unused 1: Used	0		P. 92

* These items are not used for the HA430/930.

■ Function block F52: Control 2

Name	Parameter	Data range	Factory set value	User set value	Page
Input 2_control action type selection	2. oS (2. oS)	0: Direct action 1: Reverse action	1		P. 87
Input 2_integral/derivative time decimal point position selection	2I ddP (2.I ddP)	0: No decimal place 1: One decimal place 2: Two decimal places	2		P. 87
Input 2_derivative gain	2. dGA (1. dGA)	0.1 to 10.0	6.0		P. 87
Input 2_ON/OFF action differential gap (upper)	2. oHH (2. oHH)	0 to Input span (Varies with the setting of the Decimal point position)	TC/RTD: 1.0 °C [°F] V/I: 0.1 % of input span		P. 88
Input 2_ON/OFF action differential gap (lower)	2. oHL (2. oHL)			TC/RTD: 1.0 °C [°F] V/I: 0.1 % of input span	
Input 2_action at input error (high)	2AoVE (2.AoVE)	0: Normal control 1: Manipulated output value at input error	0		P. 89
Input 2_action at input error (low)	2AUeE (2.AUnE)		0		P. 89
Input 2_manipulated output value at input error	2. PSM (2. PSM)	-5.0 to +105.0 %	-5.0		P. 90
Input 2_manipulated output value when transferred to Auto from Manual	2PSM' (2. PSM')	-5.0 to +105.0 %	—		P. 90
Input 2_output change rate limiter (up)	2. orU (2. orU)	0.0 to 1000.0 %/second of manipulated output (0.0: Unused)	0.0		P. 90
Input 2_output change rate limiter (down)	2. ord (2. ord)		0.0		P. 91
Input 2_output limiter high	2. oLH (2. oLH)	Input 2_output limiter low to 105.0 %	105.0		P. 92
Input 2_output limiter low	2. oLL (2. oLL)	-5.0 % to Input 2_output limiter high	-5.0		P. 92
Unused *	2. PFF (2. PFF)	—	0 or 1	—	—
Unused *	2PFFS (2.PFFS)	—	1.00	—	—
Input 2_MV transfer function	2MVTs (2.MVTS)	0: Unused 1: Used	0		P. 92

* These items are not used for the HA430/930.

■ Function block F53: Autotuning 1 (AT1)

Name	Parameter	Data range	Factory set value	User set value	Page
Input 1_AT bias	<i>1. ATb</i> (1. ATb)	-Input span to +Input span	0		P. 93
Input 1_AT cycle	<i>1. ATC</i> (1. ATC)	0: 1.5 cycles 2: 2.5 cycles 1: 2.0 cycles 3: 3.0 cycles	1		P. 94
Input 1_AT differential gap time	<i>1. ATH</i> (1. ATH)	0.00 to 50.00 seconds	0.10		P. 95
Input 1_AT action	<i>1. ATt</i> (1. ATt)	0: AT function (PID) 1: AT function (PI) 2: No AT function	2		P. 96

■ Function block F54: Autotuning 2 (AT2)

Name	Parameter	Data range	Factory set value	User set value	Page
Input 2_AT bias	<i>2. ATb</i> (2. ATb)	-Input span to +Input span	0		P. 92
Input 2_AT cycle	<i>2. ATC</i> (2. ATC)	0: 1.5 cycles 2: 2.5 cycles 1: 2.0 cycles 3: 3.0 cycles	1		P. 94
Input 2_AT differential gap time	<i>2. ATH</i> (2. ATH)	0.00 to 50.00 seconds	0.10		P. 95
Input 2_AT action	<i>2. ATt</i> (2. ATt)	0: AT function (PID) 1: AT function (PI) 2: No AT function	2		P. 96

■ Function block F60: Communication function

Name	Parameter	Data range	Factory set value	User set value	Page
Unused *	<i>CMPS1</i> (CMPS1)	—	0	—	—
Communication protocol selection	<i>CMPS2</i> (CMPS2)	0: RKC communication 1: Modbus 1 2: Modbus 2 10: CC-Link (1 station occupied 1 time) 11: CC-Link (1 station occupied 4 times) 12: CC-Link (1 station occupied 8 times) 13: CC-Link (4 stations occupied 1 time)	RKC communication: 0 Modbus: 2 CC-Link: 10		P. 97

* This item is not used for the HA430/930.

■ Function block F70: Set value (SV)

Name	Parameter	Data range	Factory set value	User set value	Page
Setting change rate limiter unit time	S_{HrT} (SVrT)	1 to 3600 seconds	60		P. 97
Soak time unit selection	S_{TdP} (STdP)	0: 0 hour 00 minutes 00 second to 9 hours 59 minutes 59 seconds 2: 0 minutes 00.00 seconds to 9 minutes 59.99 seconds	2		P. 97

■ Function block F71: Set value 1 (SV1)

Name	Parameter	Data range	Factory set value	User set value	Page
Input 1_setting limiter high	I_{SLH} (1. SLH)	Input 1_setting limiter low to Input 1_input scale high	Input scale high		P. 98
Input 1_setting limiter low	I_{SLL} (1. SLL)	Input 1_input scale low to Input 1_setting limiter high	Input scale low		P. 98
Input 1_PV transfer function	I_{PVTS} (1.PVTS)	0: Unused 1: Used	0		P. 98

■ Function block F72: Set value 2 (SV2)

Name	Parameter	Data range	Factory set value	User set value	Page
Input 2_setting limiter high	2_{SLH} (2. SLH)	Input 2_setting limiter low to Input 2_input scale high	Input scale high		P. 98
Input 2_setting limiter low	2_{SLL} (2. SLL)	Input 2_input scale low to Input 2_setting limiter high	Input scale low		P. 98
Input 2_PV transfer function	2_{PVTS} (2.PVTS)	0: Unused 1: Used	0		P. 98

■ Function block F91: System information display

Name	Parameter	Data range	Factory set value	User set value	Page
ROM version display	r_{oM} (roM)	Displays the version of loaded software.	—		P. 99
Integrated operating time display	W_T (WT)	0 to 99999 hours	—		P. 99
Holding peak value ambient temperature display	T_{CJ} (TCJ)	-10.0 to +100.0 °C Displays the maximum ambient temperature of the instrument.	—		P. 99
Unused *	H_{EAT} (HEAT)	—	—	—	—

* This item is not used for the HA430/930.

B. Specifications

■ Measured input

Pressure sensor input (Input 1):

Specify when ordering

Corresponding sensor: Strain gauge type of pressure sensor

Temperature input (Input 2):

Specify when ordering

TC: K, J, T, S, R, E, B, N (JIS-C1602-1995)

PL II (NBS), W5Re/W26Re (ASTM-E988-96)

RTD: Pt100 (JIS-C1604-1997)

JPt100 (JIS-C1604-1989, JIS-C1604-1981 of Pt100)

3-wire system

Voltage and Current inputs (Input 1/Input 2):

Specify when ordering

Voltage (low) group

Voltage: 0 to 1 V, 0 to 10 mV, 0 to 100 mV, ± 10 mV, ± 100 mV

Current: 0 to 20 mA, 4 to 20 mA

Input impedance: 50 Ω

Voltage (high) group

Voltage: 0 to 5 V, 1 to 5 V, 0 to 10 V, ± 1 V, ± 5 V, ± 10 V

Input range:

Refer to **Input range table (P. 25)**

Sampling cycle:

25 ms

Influence of external resistance:

0.25 $\mu\text{V}/\Omega$ (TC input)

Influence of input lead:

0.01 $^{\circ}\text{C}/\Omega$ or less 10 Ω or less per wire (RTD input)

RTD sensor current:

Approx. 1 mA

Digital filter

First order lag digital filter

Time constant: 0.00 to 10.00 seconds (0.00: OFF)

PV bias:

\pm Input span

PV ratio:

0.500 to 1.500

Zero-point calibration range (Pressure sensor):

-5.0 to +5.0 mV (Input conversion)

Gain setting range (Pressure sensor):

0.500 to 4.000 mV/V

Action at input beak:

Pressure sensor: Upscale or Downscale

TC: Upscale or Downscale

RTD: Upscale

Voltage (low): Upscale or Downscale

Voltage (high): Downscale (Indicates value near 0 V)

Current: Downscale (Indicates value near 0 mA)

Action at input short circuit: Downscale (RTD input)

Square root extraction function:

Calculation method: Measured value = $\sqrt{(\text{Input value} \times \text{PV ratio} + \text{PV bias})}$

Low level cutoff: 0.00 to 25.00 % of input span

■ Non-isolated remote input (Optional) *

*Non-isolated remote input is not available with 2-input controller (Temperature or voltage input type).

Input type:

a) 0 to 1 V, 0 to 10 mV, 0 to 100 mV, ± 10 mV, ± 100 mV

b) 0 to 5 V, 1 to 5 V, 0 to 10 V, ± 1 V, ± 5 V, ± 10 V

c) 0 to 20 mA, 4 to 20 mA

a) to c): Specify when ordering

Sampling cycle:

75 ms

Accuracy:

± 0.1 % of input span

■ Event input (Optional)

Number of inputs:	Up to 5 points
Input method:	Dry contact input OPEN (OFF) state: 500 k Ω or more CLOSE (ON) state: 10 Ω or less
Functions:	Memory area selection, RUN/STOP transfer, Remote/Local transfer, Auto/Manual transfer, Hold reset, Interlock release, Manual output up/down (Motor RPM up/down), Manual output 0 % reset (Motor RPM reset)

■ Control action

Number of control points:	Up to 2 points
Control method:	Brilliant PID control Direct action or Reverse action is available With Autotuning, Output limiter and Output change rate limiter

■ Control loop break alarm (LBA)

LBA time:	0 to 7200 seconds (0: OFF)
LBA deadband:	0 to Input span

■ Output

● Sensor power supply (Optional)

Rated voltage:	24 V DC \pm 5 %
Rated current:	24 mA max. Sensor power supply is isolated from both OUT1 and OUT2 OUT3 to OUT5: Not available

● Power supply for strain gauge type of pressure sensor

Rated voltage:	8 V DC \pm 3 %
Temperature drift:	80 ppm/ $^{\circ}$ C
Rated current:	30 mA max.

● OUT1 to OUT3 (Used for control output, event output or transmission output)

Number of outputs:	Up to 3 points (Specify when ordering) OUT3 is isolated from both OUT1 and OUT2. OUT1 and OUT2 are not isolated from each other except for relay or triac output. When relay or triac output is used, there is isolation between outputs. There is isolation between input and output. There is isolation between output and power supply terminals. If the Sensor power supply (optional) is specified, OUT3 cannot be used.
---------------------------	---

Output type:

Relay contact output

Contact type:	1a contact
Rating:	250 V AC, 3A (Resistive load)
Electrical life:	300,000 or more (Rated load)

Voltage pulse output

Output voltage:	0/12 V DC
Allowable load resistance:	600 Ω or more

Current output

Output current:	0 to 20 mA DC, 4 to 20 mA DC (Specify when ordering)
Allowable load resistance:	600 Ω or less

Voltage output

Output type:	0 to 5 V DC, 1 to 5 V DC, 0 to 10 V DC (Specify when ordering)
Allowable load resistance:	1 k Ω or more

Triac output

Output method:	AC output (Zero-cross method)
Allowable load current:	0.4 A (Ambient temperature 40 °C or less) Ambient temperature 50 °C: 0.3 A
Load voltage:	75 to 250 V AC
Minimum load current:	30 mA
ON voltage:	1.6 V or less (at maximum load current)

- **OUT4, OUT5 (Used for event output)**

Number of outputs: Up to 2 points (Specify when ordering)
If OUT3 is selected for the Sensor power supply (optional), OUT4 and OUT5 cannot be used.

Output type: **Relay contact output**

Contact type:	1a contact
Rating:	250 V AC, 1A (Resistive load)
Electrical life:	300,000 or more (Rated load)

- **Transmission output**

Number of outputs: Up to 3 points (Varies depending on the Output logic selection setting and Output type)

Output contents: Measured value, Set value, Manipulated output value and Deviation

Scaling range:

Measured value/Set value:	Same as input range
Manipulated output value:	-50 to +105.0 %
Deviation:	±Input span

■ Performance

Display accuracy (At the ambient temperature 23 °C ±2 °C):

Pressure sensor input (Strain gauge type pressure sensor)

±0.1 % of span

±0.5 % of span (When combined with pressure sensor)

TC input (K, J, T, PL II, E)

Less than -100 °C [-148 °F]: ±1.0 °C [±2.0 °F]

Less than -100 to +500 °C [-148 to +932 °F]: ±0.5 °C [±1.0 °F]

500 °C [932 °F] or more: ±(0.1 % of reading+1digit)

TC input (S, R, N, W5Re, W26Re)

Less than -100 °C [-148 °F]: ±2.0 °C [±4 °F]

Less than -100 °C to +1000 °C [-148 to +1832 °F]: ±1.0 °C [±2.0 °F]

1000 °C [1832 °F] or more: ±(0.1 % of reading+1digit)

TC input (B)

Less than 400 °C [752 °F]: ±70.0 °C [±130 °F]

Less than 400 °C to 1000 °C [752 to 1832 °F]: ±1.0 °C [±2.0 °F]

1000 °C [1832 °F] or more: ±(0.1 % of reading+1digit)

RTD input

Less than 200 °C [392 °F]: ±0.2 °C [±0.4 °F]

200 °C [392 °F] or more: ±(0.1 % of reading+1digit)

Voltage input ±0.1 % of span

Current input ±0.1 % of span

Cold-junction temperature compensation error: ±1.0 °C (At the ambient temperature 23 °C ±2 °C)
±1.5 °C (At the ambient temperature -10 to +50 °C)

Minimum indication resolution:

Pressure sensor input:

Rated pressure:	Less than 1 MPa:	0.0001 MPa
	Less than 10 MPa:	0.001 MPa
	Less than 100 MPa:	0.01 MPa
	100 MPa or more:	0.1 MPa

TC input: 0.1 °C [°F]

(The decimal point position of the input range is selectable.)

RTD input: 0.01 °C [°F]

(The decimal point position of the input range is selectable.)

Voltage/Current input: 1 to 0.0001 (Programmable)

■ Hold function

Hold type: Peak hold, Bottom hold

■ Event output function

Number of calculations: 4 points

Event type: Deviation high, Deviation low, Deviation high/low, Band, Process high, Process low, SV high, SV low, Control loop break alarm (LBA)

Additional function: Hold action (Effective only when deviation or process action is selected)
Event action at input error selection

Setting range: Deviation: -Input span to +Input span
Process: Input scale low to +Input scale high
SV: Input scale low to + Input scale high

Differential gap: 0 to Input span

■ Multi-memory area function

Number of multi-memory areas: 16 areas

Setting item for multi-memory area function:

Set value (SV), Event 1 setting, Event 2 setting, Event 3 setting, Event 4 setting, Proportional band setting, Integral time setting, Derivative time setting, Control response parameter, Setting change rate limiter (up/down), Area soak time setting, Link area number

■ Communication function (Optional)

Interface: Based on RS-232C, EIA standard
Based on RS-422A, EIA standard
Based on RS-485, EIA standard
Specify when ordering

Protocol: RKC communication (ANSI X3.28-1976 subcategories 2.5 and A4)
Modbus
PROFIBUS-DP (EN50170)
DeviceNet
CC-Link
Specify when ordering

■ Infrared communication function

Communication method: Half-duplex two-way communication

Communication speed: 9600 bps, 19200 bps

Protocol: RKC communication (ANSI X3.28-1976 subcategories 2.5 and A4)

■ Self-diagnostic function

Check items: CPU power supply voltage monitoring, Adjusted data error, EEPROM error, A/D conversion error, RAM check error, Hardware configuration error, Software configuration error, Watchdog timer error, Program busy

Action at self-diagnostic error: For CPU power supply voltage monitoring, RAM check error and Software configuration error
Display: All the display is OFF (Operation is impossible)
Output: All the output is OFF
Communication: No response
Other than the above:
Display: Error display (Operation is possible)
Output: All the output is OFF
Communication: Possible

■ Power

Power supply voltage:	90 to 264 V AC [Including power supply voltage variation] (Rating 100 to 240 V AC), 50/60 Hz	
	24 V AC $\pm 10\%$ [Including power supply voltage variation] (Rating 24 V AC), 50/60 Hz	
	24 V DC $\pm 10\%$ [Including power supply voltage variation] (Rating 24 V DC) Specify when ordering	
Power consumption:	HA430: 16.5 VA max. (at 100 V AC)	22.5 VA max. (240 V AC)
	15.0 VA max. (at 24 V AC)	430 mA max. (24 V DC)
	HA930: 17.5 VA max. (at 100 V AC)	24.0 VA max. (240 V AC)
	16.0 VA max. (at 24 V AC)	470 mA max. (24 V DC)

■ General specifications

Insulation resistance:	Between measuring terminal and grounding:	20 M Ω or more at 500 V DC
	Between power terminal and grounding:	20 M Ω or more at 500 V DC
	Between measuring terminal and power terminal:	20 M Ω or more at 500 V DC
Withstand voltage:	Between measuring terminal and grounding:	1 minute at 1000 V AC
	Between power terminal and grounding:	1 minute at 1500 V AC
	Between power and measuring terminals:	1 minute at 2300 V AC
Power failure:	A power failure of 20 ms or less will not affect the control action. If power failure of more than 20 ms occurs, controller will reset. HOT start (1, 2) or COLD start (selectable).	
Memory backup:	Backed up by non-volatile memory (EEPROM) Number of writing: Approx. 100,000 times Data retaining period: Approx. 10 years Depending on storage and operating conditions.	
Allowable ambient temperature:	-10 to +50 °C (14 to 122 °F)	
Allowable ambient humidity:	5 to 95 %RH	
	Absolute humidity: MAX.W.C 29 g/m ³ dry air at 101.3 kPa	
Ambient atmosphere:	There should be neither corrosive gases nor much dust.	
Dimensions:	HA430: 48 (W) \times 96 (H) \times 100 (D) mm	
	HA930: 96 (W) \times 96 (H) \times 100 (D) mm	
Weight:	HA430: Approx. 360 g	
	HA930: Approx. 460 g	
■ Standard		
Safety standards:	UL: UL61010-1	
	cUL: CAN/CSA-C22.2 No.61010-1	
CE marking:	LVD: EN61010-1 OVERVOLTAGE CATEGORY II, POLLUTION DEGREE 2, Class II (Reinforced insulation)	
	EMC: EN61326-1	
RCM:	EN55011	
Panel sealing:	IP65	

C. Memory Area Data List (Copy this sheet for its use.)

Sheet No.	Memory area No.	Date	Name
Display	Item	Set value	Memo
Input 1	1 SV	Set value 1 (SV1)	
	1 P	Proportional band 1	
	1 I	Integral time 1	
	1 d	Derivative time 1	
	1 rPF	Control response parameter 1	
	1SV-U	Set value 1 (SV1) change rate limiter (up)	
	1SV-d	Set value 1 (SV1) change rate limiter (down)	
Input 2	2 SV	Set value 2 (SV2)	
	2 P	Proportional band 2	
	2 I	Integral time 2	
	2 d	Derivative time 2	
	2 rPF	Control response parameter 2	
	2SV-U	Set value 2 (SV2) change rate limiter (up)	
	2SV-d	Set value 2 (SV2) change rate limiter (down)	
Common	EB1	Event 1	
	EB2	Event 2	
	EB3	Event 3 (Including LBA and LBD)	
	EB4	Event 4 (Including LBA and LBD)	
	AST	Area soak time	
	LnLA	Link area number	

Easy program operation	1	2	3	4	5	6	7	8
<p>A 1 to 3: Soak time B 1 to 3: Setting change rate limiter</p>								
Link area number								
Area soak time								
Setting change rate limiter (up)								
Setting change rate limiter (down)								

MEMO

INDEX

◆ Alphabetical order ◆

A

Action at input error (high)	89
Action at input error (low)	89
Alarm (ALM) lamp	8
Alarm lamp lighting condition setting	77
Area (AREA) lamp	8
Area soak time	40
AT action	96
AT bias	93
AT cycle	94
AT differential gap time	95
Auto calibration	49
Auto/Manual transfer	101
Auto/Manual transfer key operation selection	65
Autotuning	96
Autotuning (AT) lamp	8
Auto-zero	48
Auto-zero adjustment	44, 48

B

Bar graph display	8
Bar graph display selection	63
Bar graph resolution setting	64
Burnout direction	71

C

CC-Link communication status	30, 107
Changing Parameter Settings	28
Communication (terminal)	20, 21
Communication protocol selection	97
Communication speed	46
Control action type selection	87
Control area	114
Control loop break alarm (LBA) time	35
Control response parameter	38

D

Data bit configuration	46
Decimal point position	69
Decimal point position of MV scaling	64, 102, 106
Derivative gain	87
Derivative time	37
Device address	46
Dimensions	11
Direct key	7, 27, 65
Display unit selection	67
Dot (Bar graph)	8

E

Engineering mode	50, A-7
Event action at input error	84
Event assignment	84
Event differential gap	83
Event hold action	82
Event input logic selection	73
Event input	4, 19, 73
Event monitor	30, 106
Event set value	35
Event type selection	80

F

Full scale adjustment	44, 49
-----------------------------	--------

G

Gain setting	67
--------------------	----

H

Hold function	104
Holding peak value ambient temperature display	99
Hot/Cold start selection	85, 115

I

Infrared communication address	47
Infrared communication speed	47
Input 1 (terminal)	17, 18
Input 2 (terminal)	19
Input 2_use selection	85
Input error determination point (high)	70
Input error determination point (low)	71
Input scale high	69
Input scale low	70
Input type and input range display	25
Input type selection	66
Integral time	37
Integral/Derivative time decimal point position selection	87
Integrated operating time display	99
Interlock function	78
Interlock release	30, 106
Interval time	47

L

LBA deadband	36
Linearize type selection	68
Link area number	41

M

Manipulated output value (MV1) monitor	30, 106
Manipulated output value (MV2) monitor	30, 106
Manipulated output value at input error	90
Manipulated output value when transferred to Auto from Manual	90
Manual (MAN) mode lamp	8
Measured value (PV1)/set value (SV1) monitor	30, 102
Measured value (PV1)/ measured value (PV2) monitor	30, 103
Measured value (PV2)/set value (SV2) monitor	30, 103
Measured value 1 (PV1) lamp	8
Measured value 2 (PV2) lamp	8
Memory area soak time monitor	30, 107
Memory area	30, 107, 114
Model Code	2
Motor RPM	64, 65, 102
Mounting procedures	12
Mounting Cautions	10
MV scaling high	64, 102, 106
MV scaling low	65, 102, 106
MV transfer function	92

O

ON/OFF action differential gap (lower)	88
--	----

ON/OFF action differential gap (upper)88
 Operation Menu24
 Output (OUT1 to OUT5) lamp.....8
 Output 1 to 3 (OUT1 to OUT3) 16
 Output 4 to 5 (OUT4 to OUT5) 16
 Output change rate limiter (down)91
 Output change rate limiter (up)90
 Output limiter high.....92
 Output limiter low92
 Output logic selection.....76
 Output timer setting.....77
 Over-scale and Underscale120

P

Parameter setting mode..... 32, A-5
 PID/AT transfer101
 Power supply [terminal]..... 15
 Power supply frequency selection72
 Pressure sensor input.....14, 17, 66
 Procedure for Set Value (SV) Setting.....31
 Proportional band.....37
 Proportional cycle time.....45
 PV bias.....44
 PV digital filter44
 PV hold function.....72
 PV low input cut-off.....45
 PV ratio44
 PV transfer function98
 PV1 bottom hold value monitor.....30, 104
 PV1 hold reset30, 105
 PV1 peak hold value monitor.....30, 103
 PV2 bottom hold value monitor.....30, 105
 PV2 hold reset30, 105
 PV2 peak hold value monitor.....30, 105

R

Ramp/Soak control 40, 41, 116
 Remote input.....2, 4, 67
 Remote input (terminal) 19
 Remote input value monitor.....30, 103
 Remote/Local transfer key operation selection65
 Remote (REM) mode lamp8
 Removing procedures.....12
 Removing The Internal Assembly.....126
 ROM version display99
 RUN/STOP transfer101
 RUN/STOP transfer key operation selection65

S

Self-diagnostic error121
 Sensor power supply (terminal)20
 Set lock level.....49
 Setup setting mode 42, A-2
 Set value (SV) lamp8
 Set value (SV1) setting30
 Set value (SV2) setting30
 Setting change rate limiter (down)39
 Setting change rate limiter (up).....38
 Setting change rate limiter unit time97
 Setting limiter high98

Setting limiter low 98
 Shunt resistance output value.....68
 Soak time unit selection97
 Square root extraction selection.....72
 STOP display selection63
 SV setting & Monitor mode..... 30, A-1
 SV tracking86

T

Terminal Layout..... 14
 Transmission output scale high.....79
 Transmission output scale low79
 Transmission output type selection.....79

W

Wiring Cautions 13

◆ Required operations and functions ◆

Control panel needs to be designed and fabricated.

Dimensions	11
Wiring	13
Terminal Layout	14
Wiring of Each Terminal.....	15

The accessory, Model code and specification of this controller need to be checked.

Checking the Product.....	1
Model Code.....	2
Specifications.....	A-24

This controller needs to be installed and wired.

Mounting	10
Wiring	13
Specifications.....	A-24

Basic key operation needs to be checked.

Parts Description.....	7
Key Operation	26
Changing Parameter Settings.....	28

Initial settings need to be made before operation.

● Check of the setting procedure

Setting Procedure to Operation	22
Operation Menu	24

● Check of the parameters for controller's basic functions (Engineering mode)

Input type selection	66
Display unit selection	67
Gain setting.....	67
Linearize type selection	68
Shunt resistance output value	68
Power supply frequency selection	72
Output logic selection.....	76
Control action type selection.....	87

● Setup data setting

SETUP SETTING MODE	42
--------------------------	----

● Check of the parameter and SV

PARAMETER SETTING MODE	32
SV SETTING & MONITOR MODE	30

Set value (SV) needs to be changed.

Changing Parameter Settings.....	28
Set value (SV1) setting	30
Set value (SV2) setting	30

Direct key operation needs to be restricted.

Direct Key (F11)	65
------------------------	----

RUN/STOP needs to be switched.

Configuration of Operation Mode.....	101
RUN/STOP Transfer.....	112

Autotuning needs to be started (suspended).

Configuration of Operation Mode.....	101
AT action.....	96
Autotuning (AT) function	96

Auto/Manual needs to be switched.

Configuration of Operation Mode	101
Auto/Manual Transfer.....	108

Remote/Local needs to be switched.

Configuration of Operation Mode	101
Remote/Local Transfer.....	111

Parameter change due to misoperation needs to be prevented.

Set lock level	49
----------------------	----

Manipulated output value (MV) under Manual control needs to be manually set.

Procedure for setting the manipulated output value (MV) in Manual mode.....	110
---	-----

Control area needs to be changed.

Control Area Transfer.....	114
----------------------------	-----

The setting range of high and low limit values needs to be changed.

Setting limiter low	98
Setting limiter high.....	98

The scale range of the input range needs to be changed.

Decimal point position	69
Input scale high	69
Input scale low.....	70

Event (EV1 to EV4)

● Event output destination needs to be changed.

Output logic selection (LoGC)	76
-------------------------------------	----

● The condition of alarm lamp lighting needs to be changed.

Alarm lamp lighting condition setting (ALC1)	77
--	----

● Event action type needs to be changed.

Event type selection (ES1 to ES4)	80
Event hold action (EHO1 to EHO4)	82
Event differential gap (EH1 to EH4)	83

● Input subject to event judgment needs to be changed.

Event assignment (EVA1 to EVA4)	84
---------------------------------------	----

The assignment of event input (DI) needs to be changed.

Event input logic selection (dISL)	73
--	----

Interlock needs to be activated (or released).

Interlock function	78
Interlock release.....	30, 106

The content of transmission output needs to be changed.

Transmission output type selection.....	79
---	----

Display position of STOP characters during control STOP needs to be changed.

STOP display selection	63
------------------------------	----

The content of bar-graph display needs to be changed.

Bar graph display selection.....63
 Bar graph resolution setting.....64

The maximum and minimum PV values need to be monitored (reset).

PV hold function (1.HLdS, 2.HLdS)72
 PV1 peak hold value monitor.....30, 103
 PV1 hold reset30, 105
 PV1 bottom hold value monitor.....30, 104
 PV2 peak hold value monitor.....30, 105
 PV2 hold reset30, 105
 PV2 bottom hold value monitor.....30, 105

Motor RPM needs to be monitored.

Measured value (PV1)/set value (SV1) monitor30, 102
 Manipulated output value (MV1) monitor.....30, 106
 MV scaling high..... 64, 102, 106
 MV scaling low 65, 102, 106
 Decimal point position of MV scaling..... 64, 102, 106

Deviation of pressure displayed value needs to be calibrated. [Input 1 side]

Auto-zero.....48
 Auto calibration49
 PV bias (1. Pb).....44
 PV ratio (1. Pr)44
 Gain setting.....67
 Linearize type selection68
 Shunt resistance output value68

Measured value 2 (PV2) needs to be corrected [Input 2 side]

PV bias (2. Pb).....44
 PV ratio (2. Pr)44

Sudden change in set value or manipulated output value caused by operation mode transfer needs to be avoided.

- **When transferred to Remote from Local**
 SV tracking.....86
- **When transferred to Manual control from Auto control**
 PV transfer function98

Sudden change in output needs to be avoided by changing manipulated output variation.

Output change rate limiter (up).....90
 Output change rate limiter (down)91

Sudden change in set value caused by change in Set value (SV) needs to be avoided.

Setting change rate limiter (up).....38
 Setting change rate limiter (down)39

Response of controlled object caused by change in Set value (SV) needs to be changed.

Control response parameter38

Start operation when power failure recovers needs to be changed.

Hot/Cold start selection 85
 Start Operation when Power Failure Recovers..... 115

Ramp/soak control needs to operate.

Set value (SV1) setting..... 30
 Set value (SV2) setting..... 30
 Parameter Setting mode 32
 Setting change rate limiter unit time..... 97
 Soak time unit selection 97
 Ramp/Soak Control..... 116
 Memory Area Data List.....A-29



RKC INSTRUMENT INC.

HEADQUARTERS: 16-6, KUGAHARA 5-CHOME, OHTA-KU TOKYO 146-8515 JAPAN

PHONE: 03-3751-9799 (+81 3 3751 9799)

E-mail: info@rkcinst.co.jp

Website: <http://www.rkcinst.com/>

