Digital Alarm Indicator

REX-AC110/AC410

Instruction Manual

CAUTION

IM41AC01-E4

Thank you for purchasing the RKC instrument. In order to achieve maximum performance and ensure proper operation of your new instrument, carefully read all the instructions in this manual. Please place this manual in a convenient location for easy reference.

SYMBOLS

WARNING :

This mark indicates precautions that must be taken if there is danger of electric shock, fire, etc., which could result in loss of life or injury.

CAUTION :

This mark indicates that if these precautions and operating procedures are not taken, damage to the instrument may result.

NOTE :

Extra notes or precautions are added to operating procedures and explanations.

 : This mark indicates that all precautions should be taken for safe usage.

* : This mark is used to add extra notes, precautions or supplementary explanations to table and figures.

- This is a Class A instrument. In a domestic environment, this instrument may cause radio interference, in which case the user may be required to take adequate measures.
- This instrument is protected from electric shock by reinforced insulation. Provide reinforced insulation between the wire for the input signal and the wires for instrument power supply, source of power and loads.
- This instrument is designed for installation in an enclosed instrumentation panel. All high-voltage connections such as power supply terminals must be enclosed in the instrumentation panel to avoid electric shock by operating personnel.
- All precautions described in this manual should be taken to avoid damage to the instrument or equipment.
- All wiring must be in accordance with local codes and regulations.
- To prevent instrument damage or failure, protect the power line and the input/output lines from high currents with a protection device such as fuse, circuit breaker, etc.
- Prevent metal fragments or lead wire scraps from falling inside instrument case to avoid electric shock, fire or malfunction.
- Tighten each terminal screw to the specified torque found in the manual to avoid electric shock, fire or malfunction.
- For proper operation of this instrument, provide adequate ventilation for heat dispensation.
- Do not connect wires to unused terminals as this will interfere with proper operation of the instrument.
- Turn off the power supply before cleaning the instrument.
- Do not use a volatile solvent such as paint thinner to clean the instrument. Deformation or discoloration will occur. Use a soft, dry cloth to remove stains from the instrument.
- To avoid damage to instrument display, do not rub with an abrasive material or push front panel with a hard object.

 **WARNING**

- An external protection device must be installed if failure of this instrument could result in damage to the instrument, equipment or injury to personnel.
- All wiring must be completed before power is turned on to prevent electric shock, fire or damage to instrument and equipment.
- This instrument must be used in accordance with the specifications to prevent fire or damage to instrument and equipment.
- This instrument is not intended for use in locations subject to flammable or explosive gases.
- Do not touch high-voltage connections such as power supply terminals, etc. to avoid electric shock.
- RKC is not responsible if this instrument is repaired, modified or disassembled by other than factory-approved personnel. Malfunction can occur and warranty is void under these conditions.

NOTICE

- This manual assumes that the reader has a fundamental knowledge of the principles of electricity, process control, computer technology and communications.
- The figures, diagrams and numeric values used in this manual are only for purpose of illustration.
- RKC is not responsible for any damage or injury that is caused as a result of using this instrument, instrument failure or indirect damage.
- Periodic maintenance is required for safe and proper operation of this instrument. Some components have a limited service life, or characteristics that change over time.
- Every effort has been made to ensure accuracy of all information contained herein. RKC makes no warranty expressed or implied, with respect to the accuracy of the information. The information in this manual is subject to change without prior notice.
- No portion of this document may be reprinted, modified, copied, transmitted, digitized, stored, processed or retrieved through any mechanical, electronic, optical or other means without prior written approval from RKC.

1. PRODUCT CHECK

Check whether the delivered product is as specified by referring to the following model code list.

Model code

REX-AC110	□□□	-□*	□□□	N
	① ② ③		④⑤⑥	
REX-AC410	□□□	-□*	□□□□	
	① ② ③		④⑤⑥⑦	

④ First Alarm [ALM1]

N : No first alarm
 H : Process high alarm *1
 J : Process low alarm *1
 K : Process high alarm *2
 L : Process low alarm *2

⑥ Third Alarm [ALM3]

N : No third alarm
 H : Process high alarm *1
 J : Process low alarm *1
 K : Process high alarm *2
 L : Process low alarm *2

⑤ Second Alarm [ALM2]

N : No second alarm
 H : Process high alarm *1
 J : Process low alarm *1
 K : Process high alarm *2
 L : Process low alarm *2

⑦ Fourth Alarm [ALM4]*

N : No fourth alarm
 H : Process high alarm *1
 J : Process low alarm *1
 K : Process high alarm *2
 L : Process low alarm *2

*Fourth alarm is not provided for REX-AC110.

*1 : Without hold action

*2 : With hold action

① Input type

See 8. INPUT RANGE TABLE.

② Input range

See 8. INPUT RANGE TABLE.

③ Power supply type

3 : 24 V AC/DC 4 : 100 to 240 V AC

■ **Accessories:** Mounting brackets (2 pieces), Instruction Manual [IM41AC01-E4] (1 copy)

2. MOUNTING



WARNING

To prevent electric shock or instrument failure, always turn off the power before mounting or removing the instrument.

■ Cautions for mounting

- (1) This instrument is intended to be used under the following environmental conditions. (IEC61010-1)
 [OVERVOLTAGE CATEGORY II, POLLUTION DEGREE 2]
- (2) Avoid the following when selecting the mounting location.

- Ambient temperature of less than 0 °C or more than 50 °C.
- Ambient humidity of less than 45 % or more than 85 % RH.
- Rapid changes in ambient temperature which may cause condensation.
- Corrosive or inflammable gases.
- Direct vibration or shock to the mainframe.
- Water, oil, chemicals, vapor or steam splashes.
- Excessive dust, salt or iron particles.
- Excessive induction noise, static electricity, magnetic fields or noise.
- Direct air flow from an air conditioner.
- Exposure to direct sunlight.
- Excessive heat accumulation.

■ Dimensions

<REX-AC110>

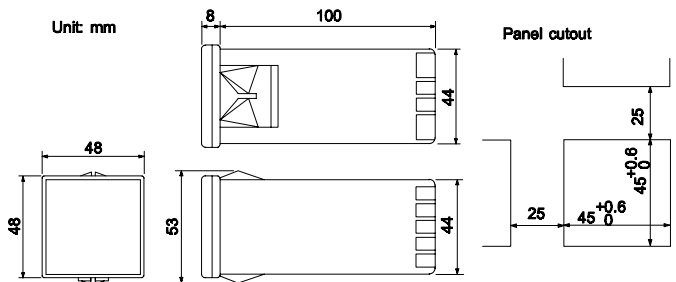

<REX-AC410>

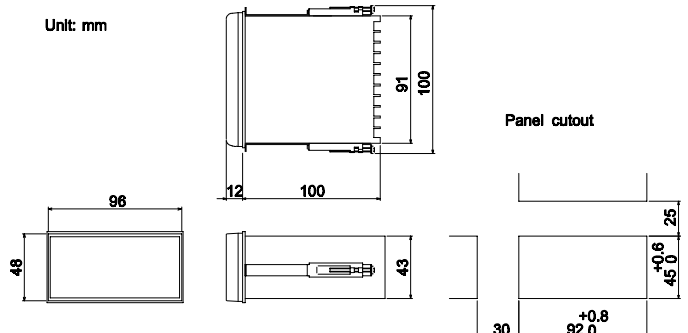

■ Mounting procedures

● REX-AC110

<When the instruments are mounted on panel with 1 to 5 mm in thickness>

Since the mounting brackets are already installed on the instrument, insert the instrument into the panel front without removal of the brackets.

<When the instruments are mounted on panel with 5 to 9 mm in thickness>

Remove the mounting brackets from the instrument with a slotted screwdriver.

Engage each mounting bracket with holes marked with "5-9" on the housing and then insert the instrument through from the panel cutout.

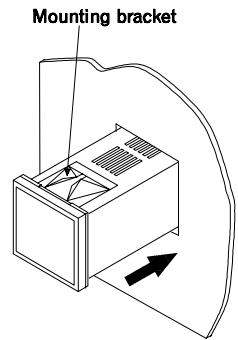

● REX-AC410

- ① Prepare the panel cutout as specified in Dimensions.
- ② Insert the instrument through the panel cutout.
- ③ Insert an upper mounting bracket along the bracket insertion groove from the back, and then engage a projection at the bracket end with a recess at the groove front and also insert metal fitting legs into slots.
- ④ Tighten a bracket setscrew from the rear of the bracket with Phillips screwdriver. Do not overtighten the bracket setscrew.
- ⑤ The other mounting bracket should be installed in the same way described in ③ and ④.

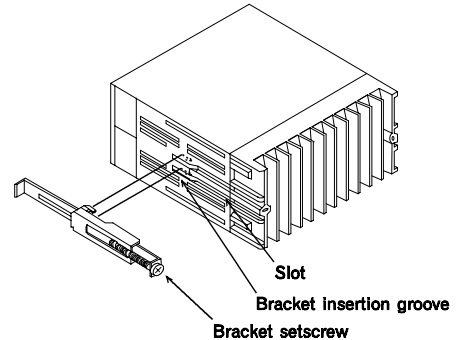

3. WIRING



To prevent electric shock or instrument failure, do not turn on the power until all the wiring is completed.

■ Cautions for wiring

- (1) For thermocouple input, use the specified compensation wire.
- (2) For RTD input, use low resistance lead wire with no difference in resistance between the three lead wires.
- (3) To avoid noise induction, keep input signal wire away from instrument power line, load lines and power lines of other electric equipment.
- (4) If there is electrical noise in the vicinity of the instrument that could affect operation, use a noise filter.
 - Shorten the distance between the twisted power supply wire pitches to achieve the most effective noise reduction.
 - Always install the noise filter on a grounded panel. Minimize the wiring distance between the noise filter output and the instrument power supply terminals to achieve the most effective noise reduction.
 - Do not connect fuses or switches to the noise filter output wiring as this will reduce the effectiveness of the noise filter.
- (5) Power supply wiring must be twisted and have a low voltage drop.
- (6) About five or six seconds are required as preparation time for contact output every time the instrument is turned on. Use a delay relay when the output line is used for an external interlock circuit.
- (7) This instrument is not furnished with a power supply switch or fuse. Therefore, if a fuse or power supply switch is required, install close to the instrument.

[Recommended fuse rating: Rated voltage 250 V, Rated current 1 A Fuse type: Time-lag fuse]
- (8) Do not excessively tighten the terminal screws. In addition, use the solderless terminal appropriate to the screw size. (Screw size : M3x6, recommended tightening torque : 0.4 N·m [4 kgf·cm])
- (9) For an instrument with 24V power supply, supply power from a SELV circuit.

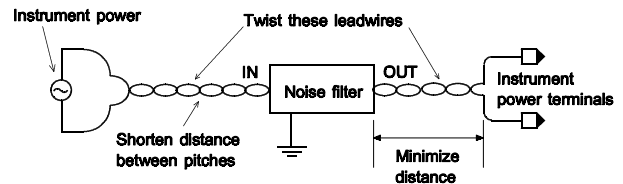

Terminal configuration

<REX-AC110>

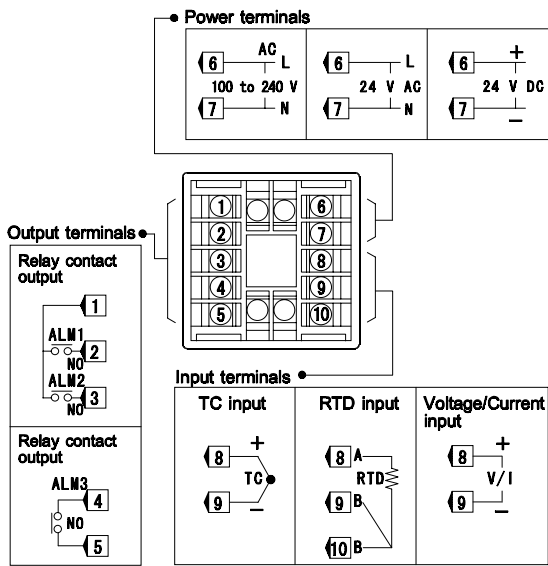

- Output rated

Relay contact output ALM1, ALM2: 250 V AC, 1 A (Resistive load) 1a contact
 ALM3, ALM4: 250 V AC, 3 A (Resistive load) 1a contact

- Power supply used

100 to 240 V AC (50/60 Hz)
 24 V AC (50/60 Hz)
 24 V DC

- Power consumptions

9 VA or less (at 240 V AC)
 6 VA or less (at 100 V AC)
 6 VA or less (at 24 V AC)
 145 mA or less (at 24 V DC)

- Crimp-style terminal lug

Therefore, use the lug suitable for a screw of M3.



Recommended tighten torque: 0.4 N·m [4 kgf·cm]

Maximum allowance tighten torque: 1 N·m [10 kgf·cm]

NOTE

Terminals which are used according to the controller type are all removed.

<REX-AC410>

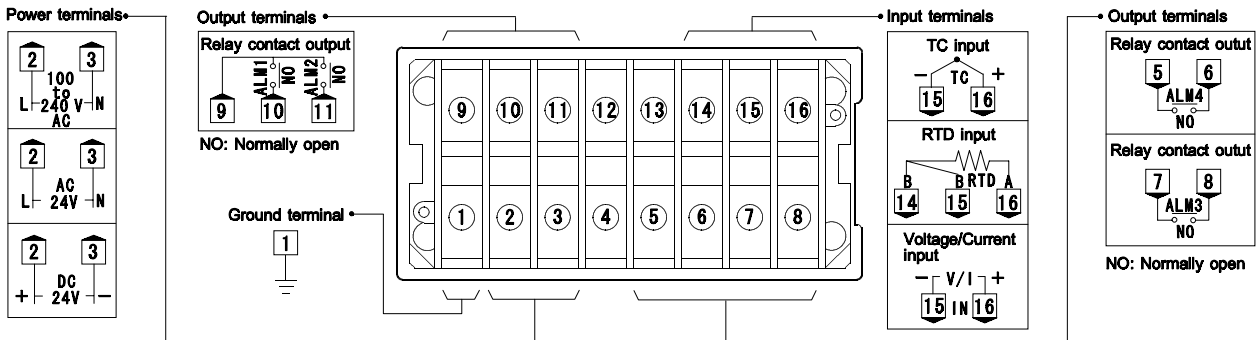

Wiring example

- When used as a temperature indicator

<REX-AC110>

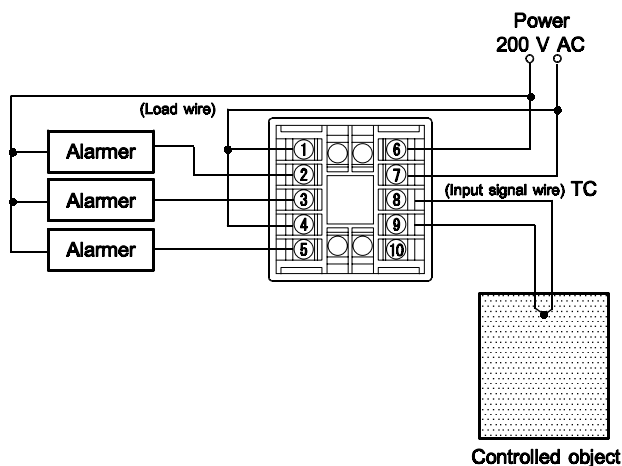

<REX-AC410>

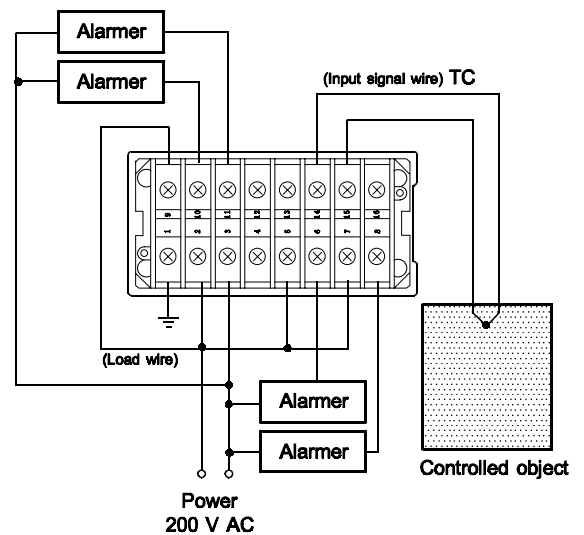

4. PARTS DESCRIPTION

<REX-AC110>

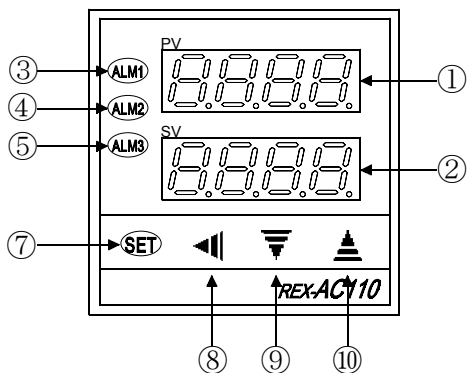

<REX-AC410>

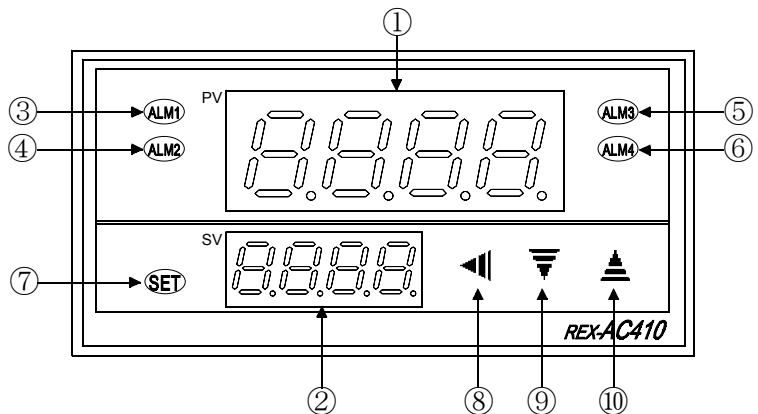

- ① Measured value (PV) display
 - Displays measured value (PV).
 - Displays a parameter symbol in the parameter setting mode and alarm set value mode.
- ② Alarm set value display
 - Displays alarm set value (ALM).
 - Displays alarm set value corresponding to the parameter symbol displayed on the measured value (PV) display.
- ③ Alarm (ALM1) lamp [Red]
 - Light when first alarm is turned on.
- ④ Alarm (ALM2) lamp [Red]
 - Light when second alarm is turned on.
- ⑤ Alarm (ALM3) lamp [Red]
 - Light when third alarm is turned on.
- ⑥ Alarm (ALM4) lamp [Red]
 - Light when fourth alarm is turned on.
- ⑦ Set (SET) key
 - The set value thus changed is entered.
 - Alarm set value mode and parameters in the parameter setting mode are selected in due order.
 - Can select PV display mode, alarm set value mode and parameter setting mode.
- ⑧ Setting digit shift key.
 - Used when the cursor (brightly lit) is moved to the digit whose number needs to be changed for set value change.
- ⑨ Set value decrement key
 - Used when the number needs to be decreased for set value change.
- ⑩ Set value increment key
 - Used when the number needs to be increased for set value change.

5. OPERATION

■ Calling-up procedure of each mode and parameter types

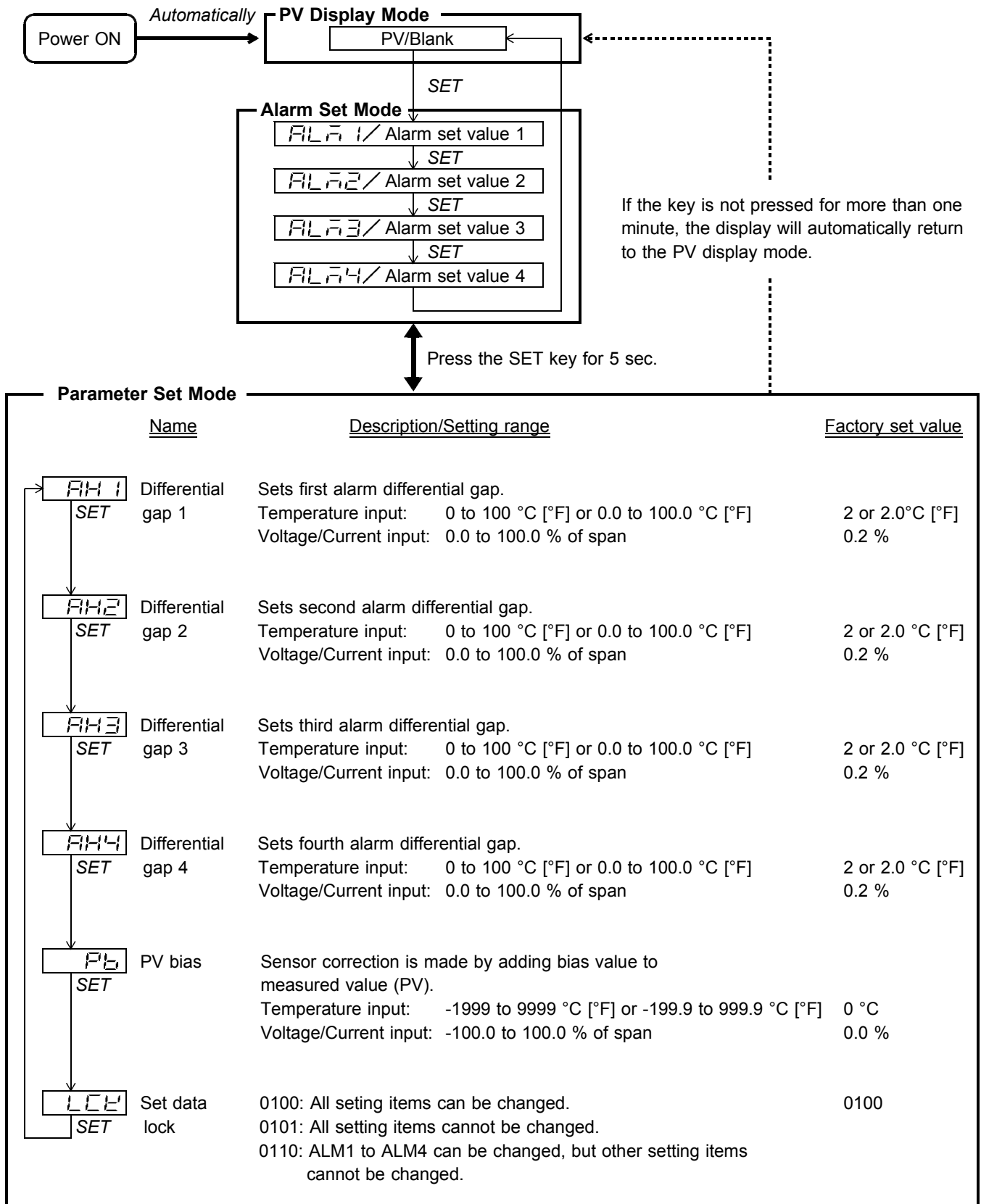

*Some parameter symbols may not be displayed depending on the specification.

Parameter setting procedure

Setting alarm set value (ALM)

When alarm set value (ALM) of 200 °C is changed to 210 °C

① Set to the Alarm setting mode.

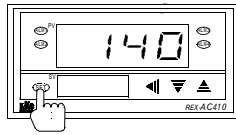

Press the SET key enter the alarm setting mode.
*When there is no alarm function, the ALM change state cannot be set.

② Shift of the digit brightly lit

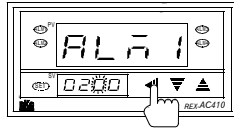

Press the SHIFT key to shift the digit which lights brightly up to the tenth digit.

③ Numeric value change



Press the UP key to set "1". Pressing the UP key increments numerals, and pressing the DOWN key decrements numerals.

④ Set value entry

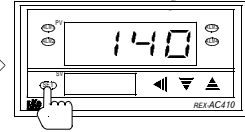

Pressing the SET key registers the numeric value as the set value to move to the next setting item or return to PV display mode.

Set value increase or decrease

Example : When a temperature of 199 °C is changed to 200 °C

Press the SHIFT key to shift the digit brightly lit to the least significant digit. Press the UP key to change "9" to "0", thereby obtaining 200 °C. The same applies to set value decrease.

Minus (-) value setting

Example : For changing 200 to -100.

Press the SHIFT key to shift the digit brightly lit to the hundreds digit. Press the DOWN key to decrement figures in order of 1 → 0 → -1.

Setting parameters other than alarm set value (ALM)

PV display mode

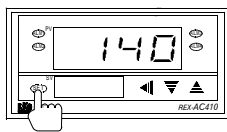

Parameter setting mode



For more than 5 sec.

Press the SET key for more than 5 sec. to set controller to the parameter setting mode.

Press the SET key by the required number of times until the parameter symbol to be set is displayed.

The setting procedures are the same as those of example ② to ④ in the above "Setting alarm set value (ALM)".

Pressing the SET key after the numeric value is changed registers that value as the set value and moves the display to the next parameter.

After the parameter is changed, press the SET key for more than 5 sec. to return to PV display mode.

Key operational cautions

- When the set value is changed, it is not automatically stored. To store it, press the SET key.
- If each value is not brightly or dimly lit even after the controller moves to alarm set value mode or parameter setting mode, the set data may be locked. In this case, change the "LCK" parameter set value to "0100."
- For this controller, if no key operation is performed for more than one minute in alarm set value mode or parameter setting mode, the controller returns to the PV display mode.

Cautions for operation

- Connect the input signal wiring and then turn on. All mounting and wiring must be completed before the power is turned on.
 - TC input Upscale or downscale
 - RTD input Upscale (Action with the input shorted : Downscale)
 - Voltage/current input Downscale (Becomes indefinite for 0 to 20 mA DC or 0 to 5 V DC.)
- A power failure of 20 ms or less will not affect the control action. When a power failure of more than 20 ms occurs, the instrument assumes that the power has been turned off. When power returns, the controller will retain the conditions that existed prior to shut down.

6. FUNCTIONS

Alarm (ALM) function

Alarm action: (Δ : Alarm set value)

Process alarm function

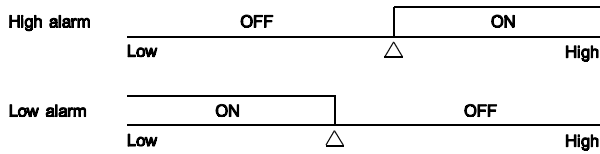

Differential gap of alarm

This function can be used to set the alarm differential gap.

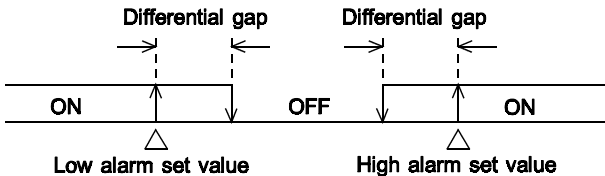

Alarm hold action

This hold action is used to make alarm invalid until the input value exits once from the alarm region by ignoring the alarm state even if the input value is in the alarm state when the power is turned on.

Set data lock function

The set data lock function permits locking of critical parameters and prevents unauthorized personnel from changing parameters.

- Press the SET key for five seconds to return to parameter setting mode to display "LCK" on the measured value (PV) display.
- Press the SHIFT, UP, and DOWN keys to set the number in the table. Thus the set data lock state can be selected.

0100	No set data locked. (All parameters changeable)
0101	Set data locked. (All parameters not changeable)
0110	Only the SV is changeable with the set data locked.

- Do not change the upper two digits "01" of the set value, as it may cause malfunction.
- Checking each set value is possible during data lock.

7. ERROR DISPLAYS

Error display

E r r	RAM failure (Incorrect set data write, etc.)	Please contact your nearest RKC sales office or agent.
--------------	--	--

Overscale and Underscale

Measured value (PV) is flashing	PV is outside of input range.	<div style="border: 1px solid black; padding: 5px;"> <p>WARNING</p> <p>To prevent electric shock, always turn off the power before replacing the sensor.</p> <p>Check the sensor or input lead.</p> </div>
0000 (0000 flashing)	Overscale PV is above the high input display range limit.	
UUUU (UUUU flashing)	Underscale PV is below the low input display range limit.	

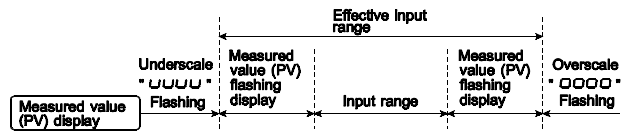

8. INPUT RANGE TABLE

TC

Input type Character	Range	Code	
K (JIS/IEC)	0 to 200°C	01	
	0 to 400°C	02	
	0 to 600°C	03	
	0 to 800°C	04	
	0 to 1000°C	06	
	0 to 1200°C	06	
	0 to 1372°C	07	
	0 to 100°C	K 13	
	0 to 300°C	14	
	0 to 450°C	17	
	0 to 500°C	20	
	0 to 800°F	A1	
	0 to 1600°F	A2	
	0 to 2502°F	A3	
	20 to 70°F	A9	
	J (JIS/IEC)	0 to 200°C	01
0 to 400°C		02	
0 to 600°C		03	
0 to 800°C		04	
0 to 1000°C		05	
0 to 1200°C		06	
0 to 450°C		J 10	
0 to 800°F		A1	
0 to 1600°F		A2	
0 to 2192°F		A3	
R#1 (JIS/IEC)	0 to 1600°C	01	
	0 to 1789°C	02	
r (JIS/IEC)	0 to 1789°C	R 04	
	0 to 3200°F	A1	
S#1 (JIS/IEC)	0 to 1600°C	01	
	0 to 1789°C	S 02	
S (JIS/IEC)	0 to 3200°F	A1	
	0 to 3216°F	A2	
B#1 (JIS/IEC)	400 to 1800°C	01	
	0 to 1820°C	B 02	
b (JIS/IEC)	800 to 3200°F	A1	
	0 to 3308°F	A2	
E (JIS/IEC)	0 to 800°C	01	
	0 to 1000°C	02	
	0 to 1600°C	E 03	
	0 to 1832°C	04	
N (JIS/IEC)	0 to 1200°C	01	
	0 to 1300°C	02	
	0 to 1000°C	N 04	
	0 to 2300°F	A1	
n (JIS/IEC)	0 to 2372°F	A2	
	-199.9 to +400.0°C	01	
T (JIS/IEC)	-199.9 to +100.0°C	02	
	-100.0 to +200.0°C	03	
	0.0 to 350.0°C	T 04	
	-199.9 to +752.0°F	A1	
	-100.0 to +200.0°F	A2	
	-100.0 to +400.0°F	A3	
	0.0 to 450.0°F	A4	
	0.0 to 752.0°F	A5	
	WSRe/W25Re (ASTM)	0 to 2000°C	W 01
		0 to 2320°C	02
0 to 4000°F		A1	
PL II (NBS)	0 to 1300°C	01	
	0 to 1380°C	02	
	0 to 1200°C	A 03	
	0 to 2400°F	A1	
p (JIS/IEC)	0 to 2534°F	A2	

#1 : Accuracy is not guaranteed between 0 to 399°C (0 to 799°F).

Input type Character	Range	Code
U (DIN)	-199.9 to +800.0°C	01
	-199.9 to +100.0°C	02
	0.0 to 400.0°C	U 03
	-199.9 to +889.9°F	A1
	-100.0 to +200.0°F	A2
L (DIN)	0 to 400°C	01
	0 to 800°C	02
	0 to 1600°C	L A2

RTD

Input type Character	Range	Code	
Pt100 (JIS/IEC)	-199.9 to +849.0°C	01	
	-199.9 to +200.0°C	02	
	-100.0 to +50.0°C	03	
	-100.0 to +100.0°C	04	
	-100.0 to +200.0°C	05	
	0.0 to 50.0°C	06	
	0.0 to 100.0°C	07	
	0.0 to 200.0°C	08	
	0.0 to 300.0°C	09	
	0.0 to 500.0°C	10	
P100 (JIS/IEC)	-199.9 to +849.0°C	A1	
	-199.9 to +400.0°F	A2	
	-100.0 to +100.0°F	A4	
	-100.0 to +300.0°F	A5	
	0.0 to 100.0°F	A6	
	0.0 to 200.0°F	A7	
	0.0 to 400.0°F	A8	
	0.0 to 500.0°F	A9	
	JPT100 (JIS)	-199.9 to +849.0°C	01
		-199.9 to +200.0°C	02
-100.0 to 50.0°C		03	
-100.0 to +100.0°C		04	
-100.0 to +200.0°C		05	
0.0 to 50.0°C		06	
0.0 to 100.0°C		07	
0.0 to 200.0°C		08	
0.0 to 300.0°C		09	
0.0 to 500.0°C		10	

Voltage/Current

Input type Character	Range	Code
0 to 5 V 1 to 5 V	0.0 to 100.0 %	4 01
	0.0 to 100.0 %	6 01
0 to 20 mA 4 to 20 mA	0.0 to 100.0 %	7 01
	0.0 to 100.0 %	8 01
(Other)	0.0 to 100.0 %	9 01

RKC. RKC INSTRUMENT INC.

HEADQUARTERS: 16-6, KUGAHARA 5-CHOME, OHTA-KU TOKYO 146-8515 JAPAN

PHONE: 03-3751-9799 (+81 3 3751 9799)

E-mail: info@rkinst.co.jp

FAX: 03-3751-8585 (+81 3 3751 8585)