

REF-900

INSTRUCTION MANUAL

RKC[®] RKC INSTRUMENT INC.

IM900F01-E6

Thank you very much for your purchase of our Model "REX-F900" digital controllers. Prior to operating the controller, carefully read this instruction manual. The contents of the INSTRUCTION MANUAL are subject to change without notice. The instrument was manufactured and delivered under close quality control by us. However, if you have any questions regarding the manual, contact one of our sales people, our nearest sales office, or the place where you have purchased this controller.

This manual consists of the following 5 chapters.

Chapter 1 PREPARATION	Describes handling procedures and also mounting and wiring procedures required prior to operation.
Chapter 2 OPERATION	Describes setting and each operation status, and also operation procedures.
Chapter 3 ENGINEER LEVEL	Describes the details of engineer level in which setting items related to functions and specifications are collected.
Chapter 4 MAINTENANCE	Describes maintenance, inspection, and display and measures to be taken when error occurs.
Chapter 5 SPECIFICATION	Summarizes REX-F900 specifications.

CONTENTS

Chapter 1	PREPARATION	5
1.	HANDLING PROCEDURE	5
2.	MODEL CODE	6
3.	MOUNTING	8
3.1	Dimensions	8
3.2	Mounting procedures	9
3.3	Cautions for mounting	9
4.	WIRING	10
4.1	Terminal configuration	10
4.2	Cautions for wiring	12
4.3	Wiring example	14
Chapter 2	OPERATION	16
1.	NAME OF PARTS	16
2.	OPERATION	18
2.1	Calling-up procedure of each status	18
2.2	Monitoring (MONI) status	20
2.3	Set (SET) status	22
2.4	Area (AREA) status	27
2.5	Mode (MODE) status	28
2.6	Contact input usage	31
2.7	Feedback resistance adjustment	32
3.	CAUTIONS FOR OPERATION	34
3.1	Operation execution (RUN)/STOP	34
3.2	Requirements for auto-tuning (AT)	35
3.3	Action during power failure	36
Chapter 3	ENGINEER LEVEL	37
1.	OVERVIEW OF ENGINEER LEVEL	37
1.1	Engineer level calling procedure	37
1.2	Parameter list	38
2.	DESCRIPTION OF EACH PARAMETER	40
2.1	PV (measured-value) section [Parameter group (PG) 10]	40
2.2	RS (remote setting input) section [Parameter group (PG) 11]	40
2.3	Output section [Parameter group (PG) 12]	41
2.4	AT (auto-tuning) section [Parameter group (PG) 13]	41
2.5	Alarm section 1 [Parameter group (PG) 14]	42
2.6	Analog output section [Parameter group (PG) 15]	43
2.7	Position proportioning PID action section [Parameter group (PG) 16]	43
2.8	Bar-graph section [Parameter group (PG) 17]	44

2.9	Input section		
	[Parameter group (PG) 20]	45
2.10	Setting section		
	[Parameter group (PG) 21]	47
2.11	Control section		
	[Parameter group (PG) 22]	48
2.12	Alarm section 2		
	[Parameter group (PG) 23]	49
2.13	Communication section		
	[Parameter group (PG) 24]	50
2.14	Data lock section		
	[Parameter group (PG) 40]	51
Chapter 4	MAINTENANCE	53
1.	MAINTENANCE AND INSPECTION	53
2.	TROUBLESHOOTING	54
3.	DISPLAY AT ABNORMALITY	56
Chapter 5	SPECIFICATION	58
INDEX		72
1.	CHARACTER INDEX	72
2.	INDEX	78

Chapter 1 PREPARATION

1. HANDLING PROCEDURE

Conduct necessary work according to the following procedures:

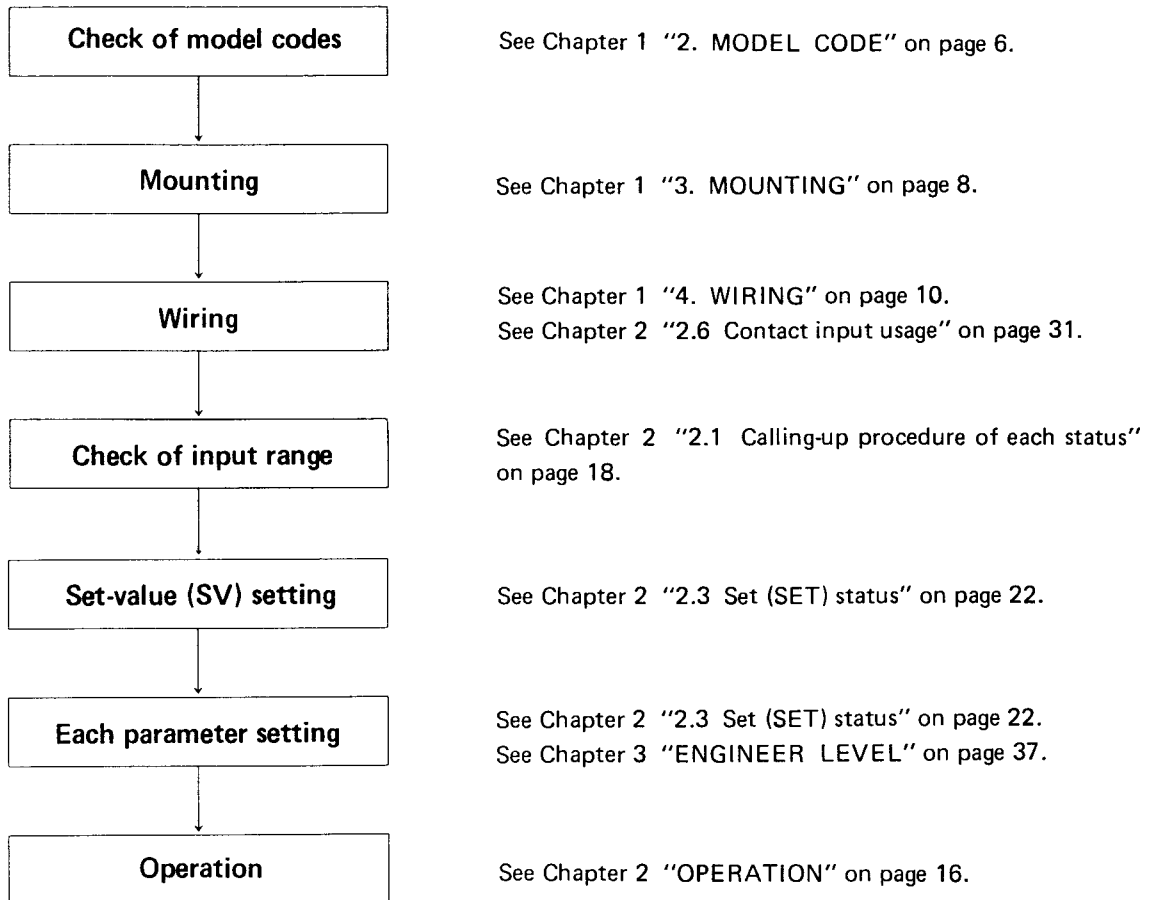

Cautions

1. Connect the input signal wiring, and then turn ON the power. If the input signal wiring opens, the controller judges that input is disconnected to cause the upscale or downscale of measured-value (PV) display.
Upscale For TC or RTD input
Downscale For TC (To be specified when ordering), voltage or current input
2. For position proportioning PID action, it is recommended that feedback resistance be adjusted prior to operation. For the feedback resistance adjustment, see Chapter 2 "2.7 Feedback resistance adjustment" on page 32.

2. MODEL CODE

Check the model code from the following list to determine if the product delivered is as desired.

■ Model code

REX-F900 model code

F900 □ □ □ - □ □ * □ □ - □ □ □ - □ □
 ① ② ③ ④ ⑤ ⑥ ⑦ ⑧ ⑨ ⑩ ⑪ ⑫

- | | | |
|---|--|--|
| <p>① Control action
 A : ON/OFF action *1
 F : PID action with auto-tuning
 V : Heating/cooling PID action
 Y : Position proportioning PID action *2</p> <p>② Input type
 See input range table "Model code" on page 7</p> <p>③ Input range
 See input range table "Mode code" on page 7</p> <p>④ First control output [OUT1]
 M : Relay contact
 V : Voltage pulse
 G : Trigger (for triac driving)
 4 : Continuous voltage 0 to 5V DC
 5 : Continuous voltage 0 to 10V DC
 6 : Continuous voltage 1 to 5V DC
 7 : Current 0 to 20mA DC
 8 : Current 4 to 20mA DC</p> <p>⑤ Second control output [OUT2]
 No symbol : When control action is A, F or Y
 Specified for heating/cooling PID action (V). The symbol is the same as that in item ④.
 [However, no trigger output (G) can be specified.]</p> | <p>⑥ First alarm
 A : Deviation high alarm *3
 B : Deviation low alarm *3
 C : Deviation high/low alarm *3
 D : Band alarm
 E : Deviation high alarm *4
 F : Deviation low alarm *4
 G : Deviation high/low alarm *4
 H : Process high alarm *3
 J : Process low alarm *3
 K : Process high alarm *4
 L : Process low alarm *4
 M : FAIL alarm
 N : No first alarm</p> <p>⑦ Second alarm
 A : Deviation high alarm *3
 B : Deviation low alarm *3
 C : Deviation high/low alarm *3
 D : Band alarm
 E : Deviation high alarm *4
 F : Deviation low alarm *4
 G : Deviation high/low alarm *4
 H : Process high alarm *3
 J : Process low alarm *3
 K : Process high alarm *4
 L : Process low alarm *4
 M : FAIL alarm
 P : Heater break alarm
 CTL-6-P-N *5
 S : Heater break alarm
 CTL-12-S56-10L-N *5
 N : No second alarm</p> | <p>⑧ Remote input *5
 1 : Voltage 0 to 10mV DC
 2 : Voltage 0 to 100mV DC
 3 : Voltage 0 to 1V DC
 4 : Voltage 0 to 5V DC
 5 : Voltage 0 to 10V DC
 6 : Voltage 1 to 5V DC
 7 : Current 0 to 20mA DC
 8 : Current 4 to 20mA DC
 N : No remote input</p> <p>⑨ Contact input
 1 : Memory area transfer
 2 : AUTO/MAN transfer
 3 : REM/LOC transfer
 4 : COMP/LOC transfer
 5 : Memory area transfer and AUTO/MAN transfer
 6 : Memory area transfer and REM/LOC transfer
 7 : Memory area transfer and COMP/LOC transfer
 N : No contact input</p> <p>⑩ Analog output
 1 : Voltage 0 to 10mV DC
 2 : Voltage 0 to 100mV DC
 3 : Voltage 0 to 1V DC
 4 : Voltage 0 to 5V DC
 5 : Voltage 0 to 10V DC
 6 : Voltage 1 to 5V DC
 7 : Current 0 to 20mA DC
 8 : Current 4 to 20mA DC
 N : No analog output</p> <p>⑪ Communication
 1 : RS-232C
 4 : RS-422A
 5 : RS-485
 N : No communication</p> <p>⑫ Front sheet color
 N : Standard color [Blue base]
 A : Black base</p> |
|---|--|--|

*1 For ON/OFF action, only the [M, V and G] can be specified as control outputs.
 *2 For position proportioning PID action, only the [M] can be specified as control outputs.
 *3 Without hold action
 *4 With hold action
 *5 No common use of heater break alarm and remote input is available.

Caution

Items ②, ③, ⑥, ⑦ or ⑧ can be changed on your side. If this change was made, please enter the new Model code in space of the Model code seals stuck inside and outside the instrument.

■ Input range table

Group		Input type		Model code	
Temperature input	TC	K (℄)	-199.9 to 300.0℃	K	08
			0.0 to 400.0℃		09
			0.0 to 800.0℃		10
			0 to 1300 ℃		11
			0.0 to 800.0℉		A4
		0 to 2400 ℉	A5		
		J (℄)	-199.9 to 300.0℃	J	07
			0.0 to 400.0℃		08
		R (℄)	0.0 to 800.0℃	R	09
			0 to 1200 ℃		06
		S (℄)	0.0 to 700.0℉	S	A4
			0 to 2100 ℉		A5
		B (b) #	0 to 1700 ℃	B	03
			0 to 3200 ℉		A1
E (℄)	0 to 1700 ℃	E	03		
	0 to 3200 ℉		A1		
T (℄)	0 to 1800 ℃	T	03		
	0 to 3300 ℉		A3		
	0.0 to 700.0℃		02		
N (℄)	0 to 1000 ℃	N	A3		
	0 to 1800 ℉		05		
	-199.9 to 300.0℃		06		
PLII (℄)	0.0 to 400.0℃	A	A6		
	-199.9 to 400.0℉		A7		
	0.0 to 700.0℉		02		
W5Re/W26Re (℄)	0 to 1300 ℃	W	A1		
	0 to 2300 ℉		01		
U (℄)	0 to 2300 ℃	U	03		
	0 to 4200 ℉		A2		
L (℄)	0.0 to 600.0℃	L	04		
	0 to 1100 ℉		A4		
RTD	JPt100 (℄℄)	P	04		
			-100.0 to 100.0℃	11	
RTD	Pt100 (℄℄)	D	B1		
			-199.9 to 500.0℃	B2	
Voltage input	Voltage input (Low)	mV, V (℄)	-150.0 to 200.0℉	1	01
			-199.9 to 900.0℉		
Voltage input	Voltage input (High)	V (℄)	0 to 10mV	3	01
			0 to 100mV		
Voltage input	Voltage input (High)	V (℄)	0 to 1 V	5	01
			0 to 5 V		
Current input	mA (℄)		1 to 5 V	7	01
			0 to 10 V		
Current input		mA (℄)	0 to 20mA	7	01
			4 to 20mA		

. Accuracy in the range of 0 to 400°C (0 to 800°F): Not guaranteed.

3. MOUNTING

3.1 Dimensions

Unit: mm (inch)

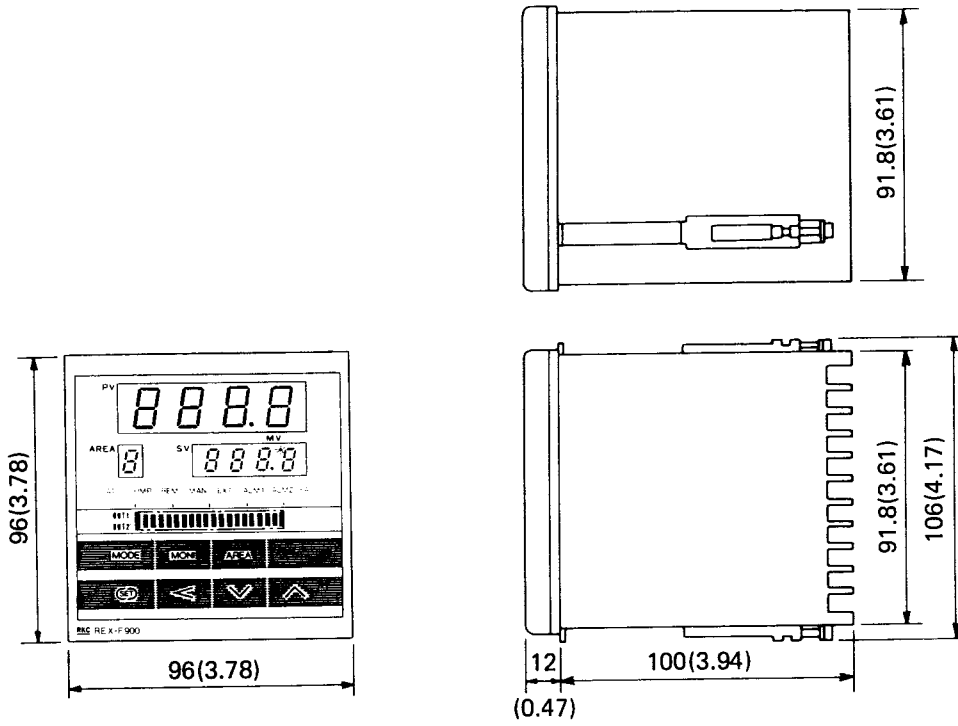

Panel cutout

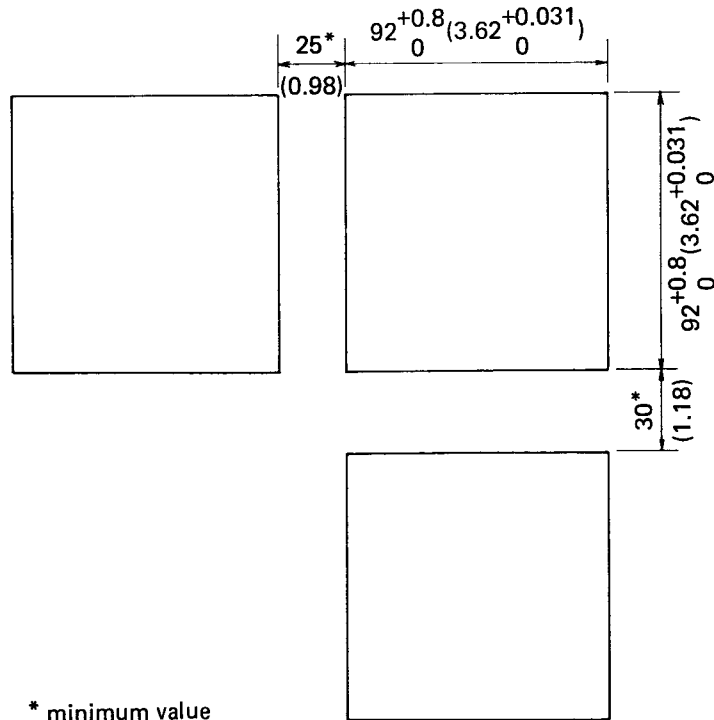

* minimum value

☆ Dimensions in inches are shown for reference.

3.2 Mounting procedures

- ① Mount the panel cutout corresponding to the number of units on the panel by referring to panel cutout dimensions.
- ② Insert the instrument into the panel from the front side.
- ③ Engage each mounting bracket with the bracket insertion slots (Fig. 1).
- ④ Then tighten the mounting bracket setscrew from the rear with a Phillips screwdriver (Fig. 2). Do not overtighten the bracket setscrew.
- ⑤ Engage the other bracket with the slots in the same way as in items ③ and ④.

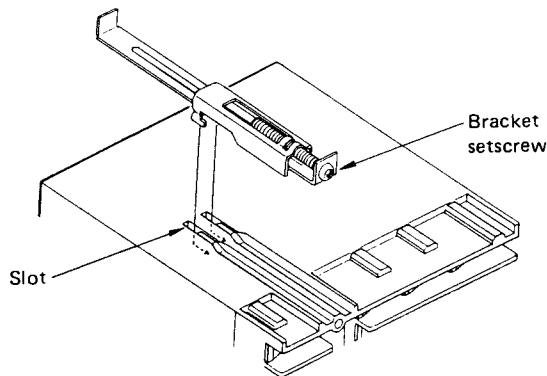

Fig. 1

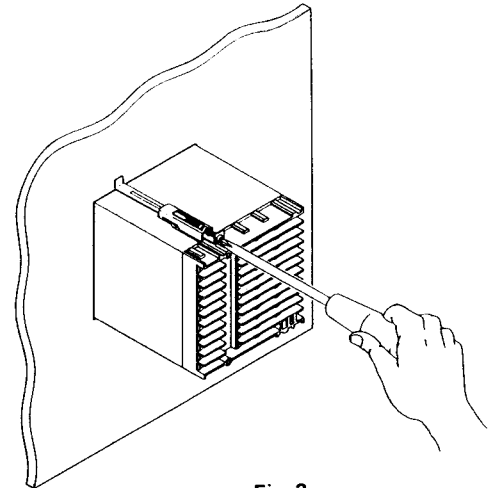

Fig. 2

3.3 Cautions for mounting

Avoid the following location where the controller is mounted.

- Location where ambient temperature is more than 50°C (122°F) or less than 0°C (32°F).
- Location where humidity is high.
- Location where corrosive gas is generated.
- Location where strong vibration and shock exist.
- Location where flooding and oil splash exist.
- Location where much dust exists.
- Location where inductive disturbance is large and other location where bad influence is exerted on electric instrument.

4. WIRING

4.1 Terminal configuration

Conduct wiring by referring to following diagrams.

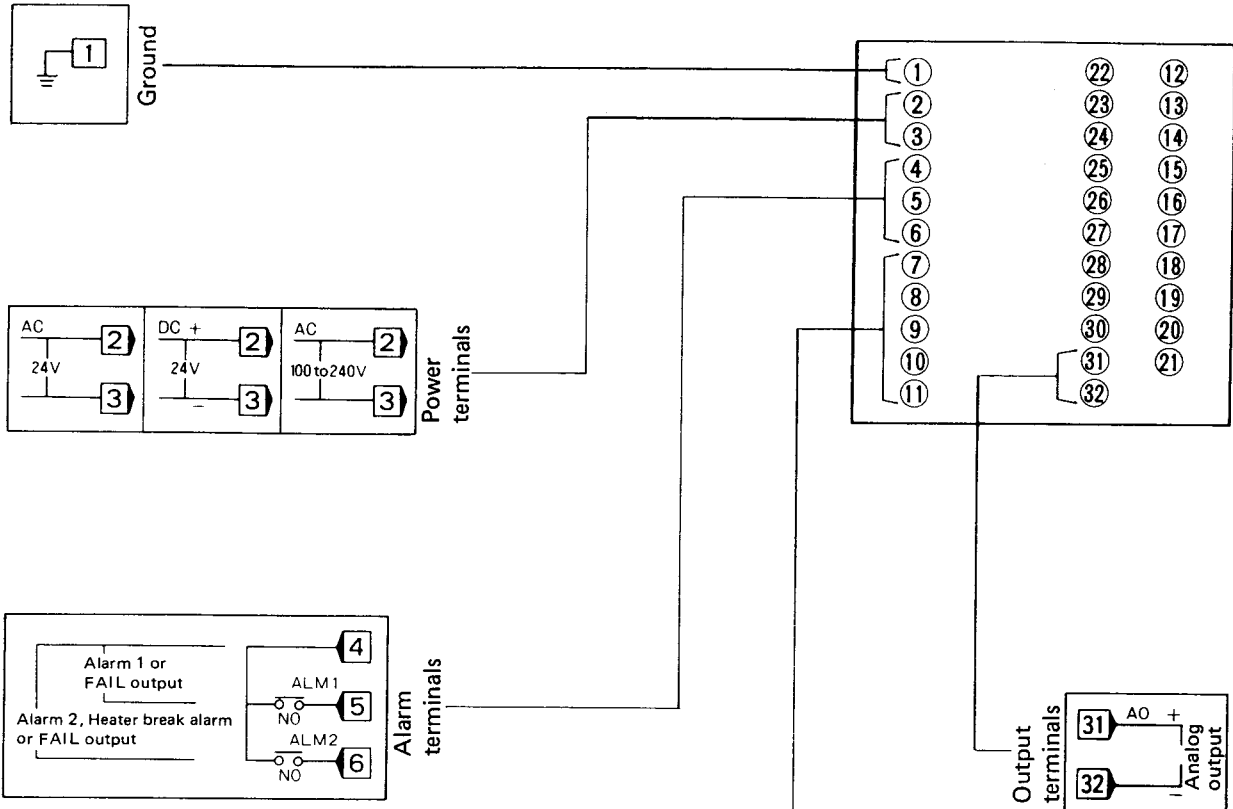

- **Output rated**
Relay contact output : 250V AC 1A (Resistive load)

- **Output rated**
Voltage output
: 0 to 10mV DC
: 0 to 100mV DC
: 0 to 1 V DC
: 0 to 5 V DC
: 0 to 10 V DC
: 0 to 5 V DC
Current output
: 0 to 20mA DC
: 4 to 20mA DC

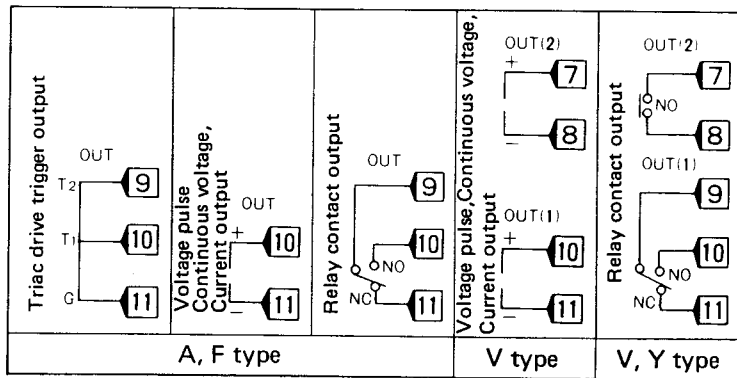

- A: ON/OFF action
- F: PID action with auto-tuning
- V: Heating/cooling PID action
- Y: Position proportioning PID action

- OUT(1): Heating-side (V), Open (Y)
- OUT(2): Cooling-side (V), Closed (Y)
- NO: Normally open
- NC: Normally closed

- **Output rated**
Relay contact output : 250V AC 3A (Resistive load)
Voltage pulse output : 0/12V DC
Continuous voltage output : 0 to 5V DC, 0 to 10V DC, 1 to 5V DC
Current output : 0 to 20mA DC, 4 to 20mA DC

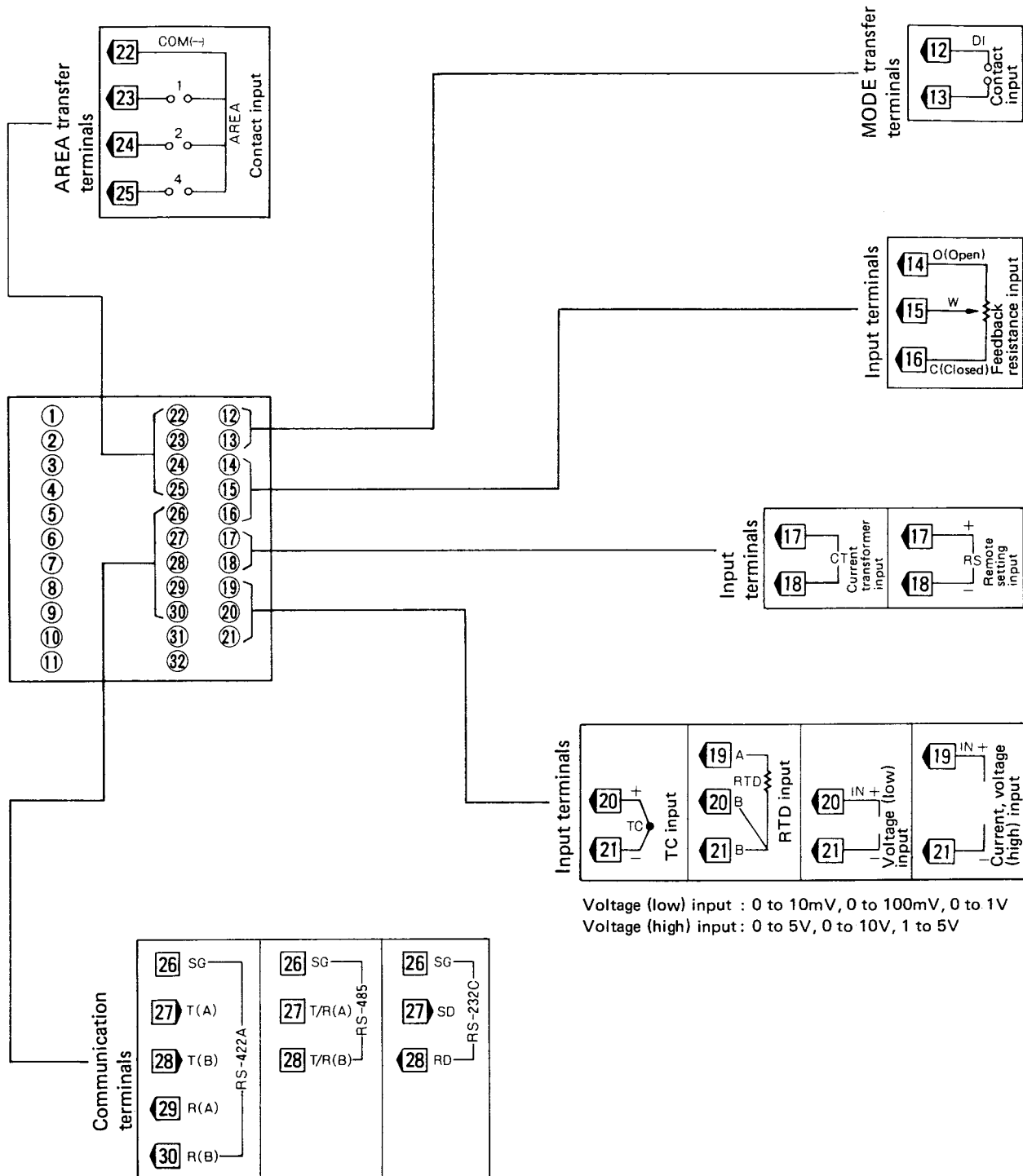

Cautions

1. Terminals which are not used according to the controller type are all removed.
2. For thermocouple input, the temperature compensation element in the internal assembly is projected from the lower part of the terminal No. 21.
Do not damage the above temperature compensation element when the internal assembly is removed from the case.
3. Use solderless terminals with 6.2mm wide or less.

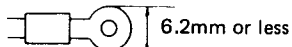

4.2 Cautions for wiring

- (1) For thermocouple input, use the specified compensation wire.
- (2) For RTD input, use leads with low resistance and having no resistance differences between the 3 leads.
- (3) Conduct input signal wiring away from instrument power, electric equipment power and load lines as such as possible to avoid noise induction.
- (4) When a shielded lead is used, ground the shield as follows to prevent noise generated by both stray capacitance between the shield and each conductor, and by the shield potential difference with the earth.
 - ① When a signal source is grounded, ground one end of the shield near the source.

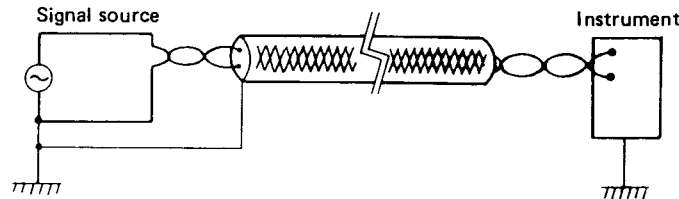

- ② If no signal source is grounded, ground one end of the shield near the instrument.

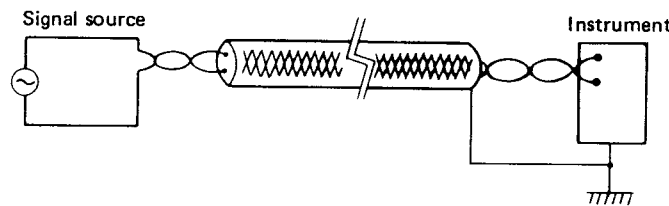

- (5) Conduct instrument power wiring so as not to be influenced by noise from the electric equipment power. If it is assumed that a noise generation source is located near the controller and the controller is influenced by noise, use a noise filter.
 - ① To obtain a satisfactory noise filter effect, select the most suitable type after due consideration of instrument power supply voltage and filter frequency characteristics.
 - ② For instrument power wiring, if it is assumed that noise exerts a bad influence upon the controller, shorten the distance between twisted power supply wire pitches. (The shorter the distance between the pitches, the more effective for noise reduction.)
 - ③ Install the noise filter on the panel which is always grounded and minimize the wiring distance between the noise filter output side and the instrument power terminals. Otherwise, the longer the distance wiring, the less effective for noise.
 - ④ Do not install fuses and/or switches on the filter output signal since this may lessen filter effect.

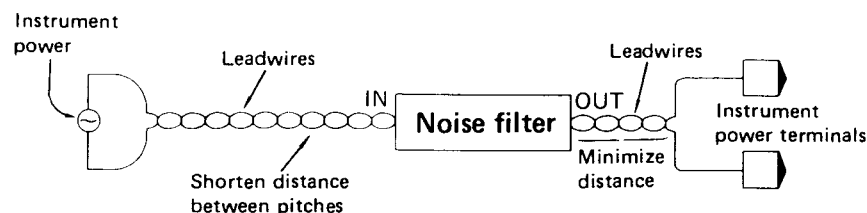

- (6) For wiring, use wires conforming to the domestic standard of each country. (For instrument grounding, use wires with nominal sectional area of 1.25 to 2.0mm², and securely ground the instrument at the minimum distance.)
- (7) About 3 sec. are required as the preparation time of contact output during power-ON. Use a delay relay when the output line, is used for an external interlock circuit.

(8) Display accuracy of current transformer (CT) input value at heater break alarm is within $\pm 5\%$ of input value or $\pm 2A$, whichever is greater.
 Therefore, when a heater break alarm is used, set load current flowing through the current transformer (CT) at a value to be sufficiently large.

(9) The following diagram shows the REX-F900 circuit configuration. Since the inside output circuit, inside input circuit and MCU section and input circuit, and the communications and contact input sections are not isolated, exercise care in wiring.

[Examples]

1. Since measured-value (PV) input and remote setting (RS) input circuits are not isolated, parallel remote setting signal inputs to two or more REX-F900s using grounding type thermocouples cause abnormal display owing to the formation of an abnormal loop between the above REX-F900s through thermocouple grounding.
2. Since heating-side output and cooling-side output circuits are not isolated in heating/cooling PID action, for the control output type of current or for continuous voltage, the connection of the above output to actuators with the output minus (or plus) sides connected in common may disable normal control.

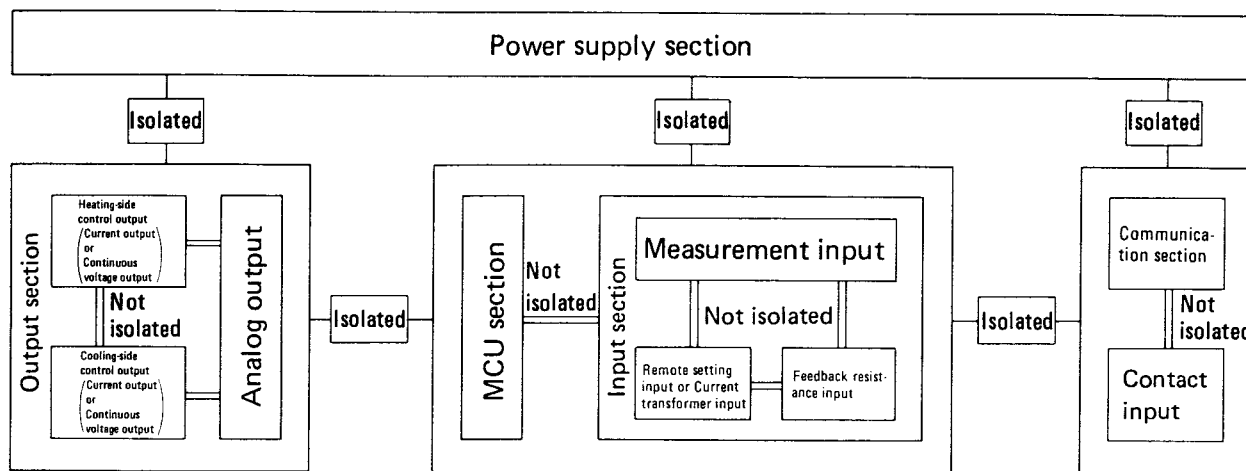

REX-F900 circuit configuration

4.3 Wiring example

(1) Wiring example by action type

■ PID action with auto-tuning type

F900F□□-M*AN-N4N-1□

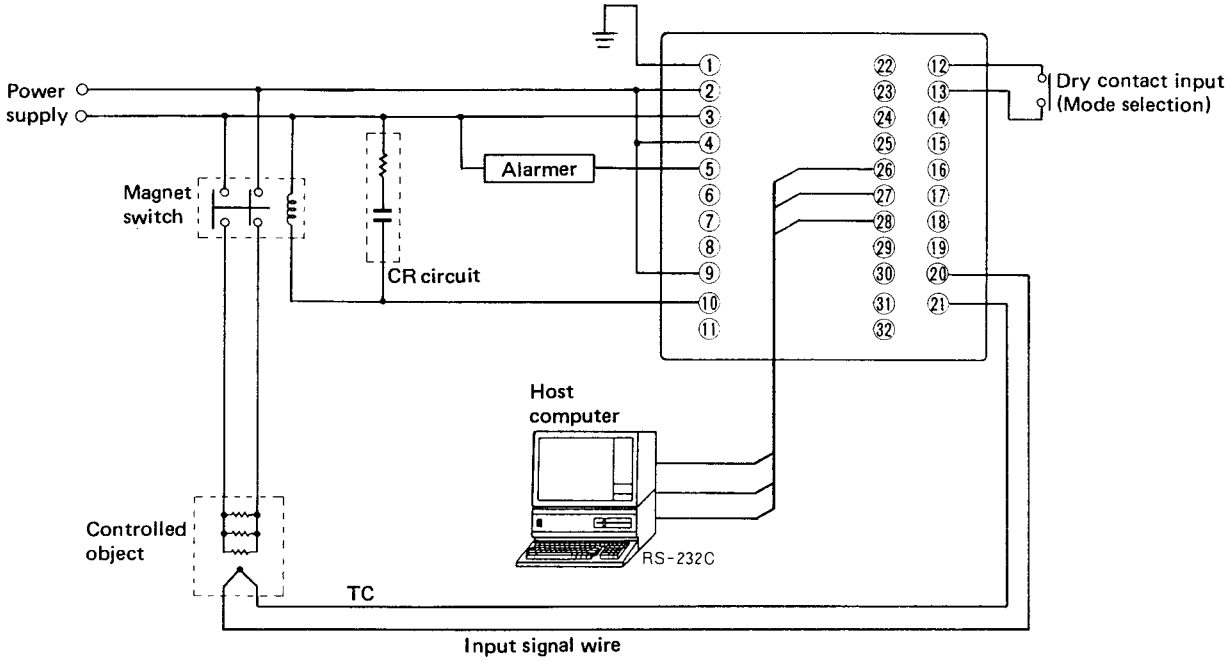

■ Heating/Cooling PID action type

F900V□□-MM*AP-N51-4□

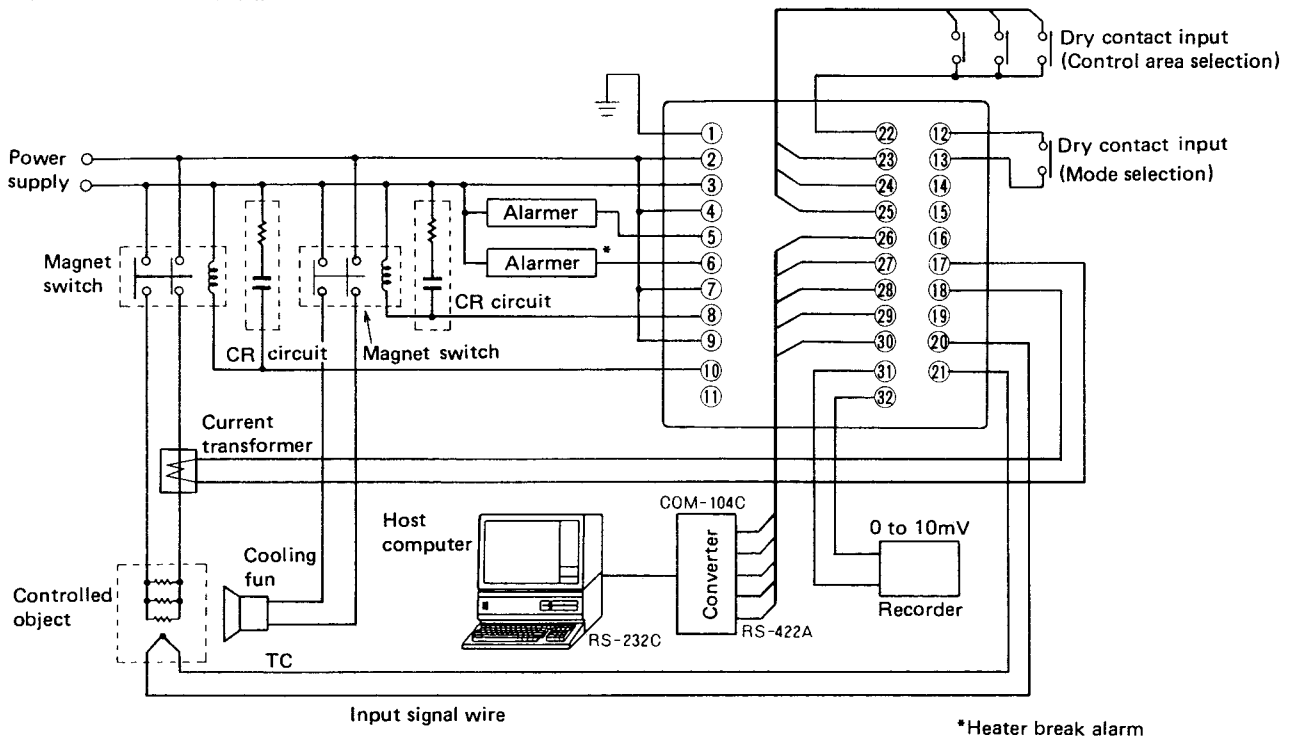

■ Position proportioning PID action type

F900Y□□-M*AM-651-5□

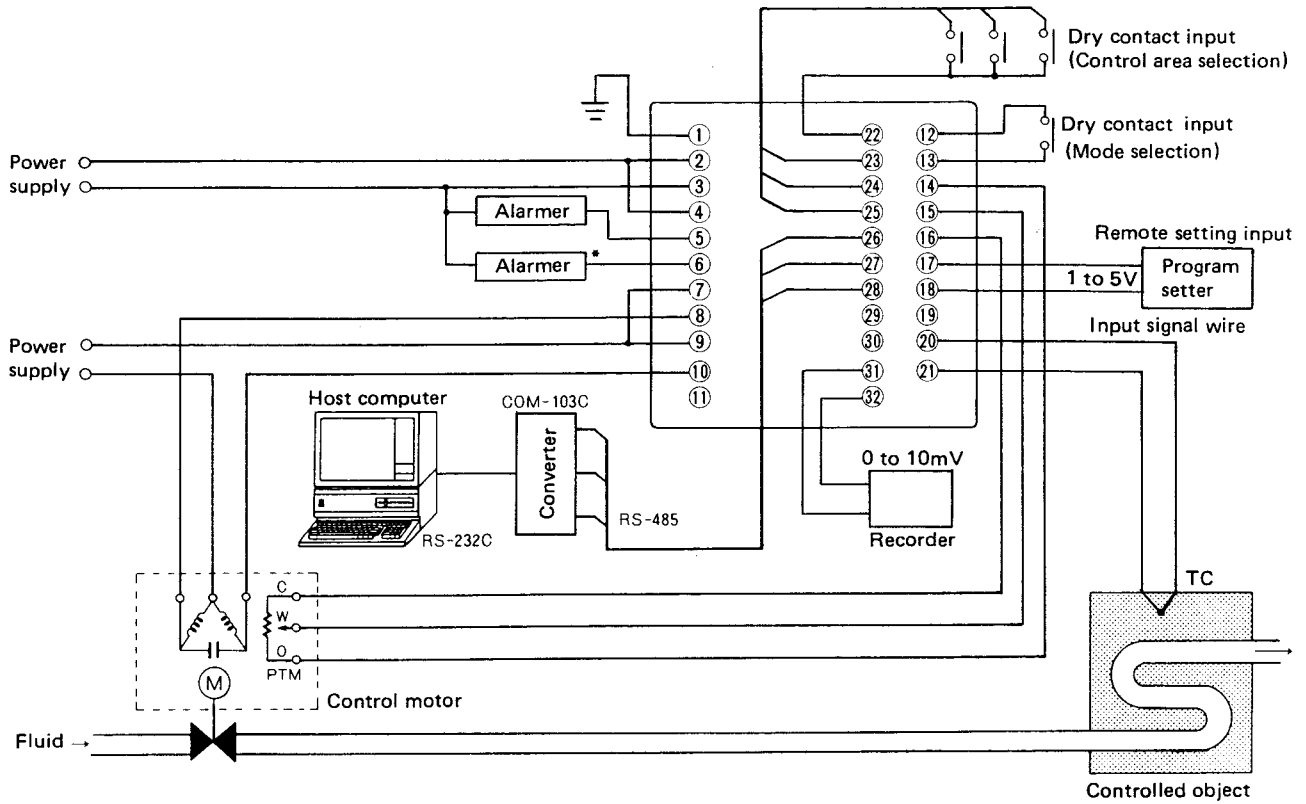

*FAIL alarm

Chapter 2 OPERATION

1. NAME OF PARTS

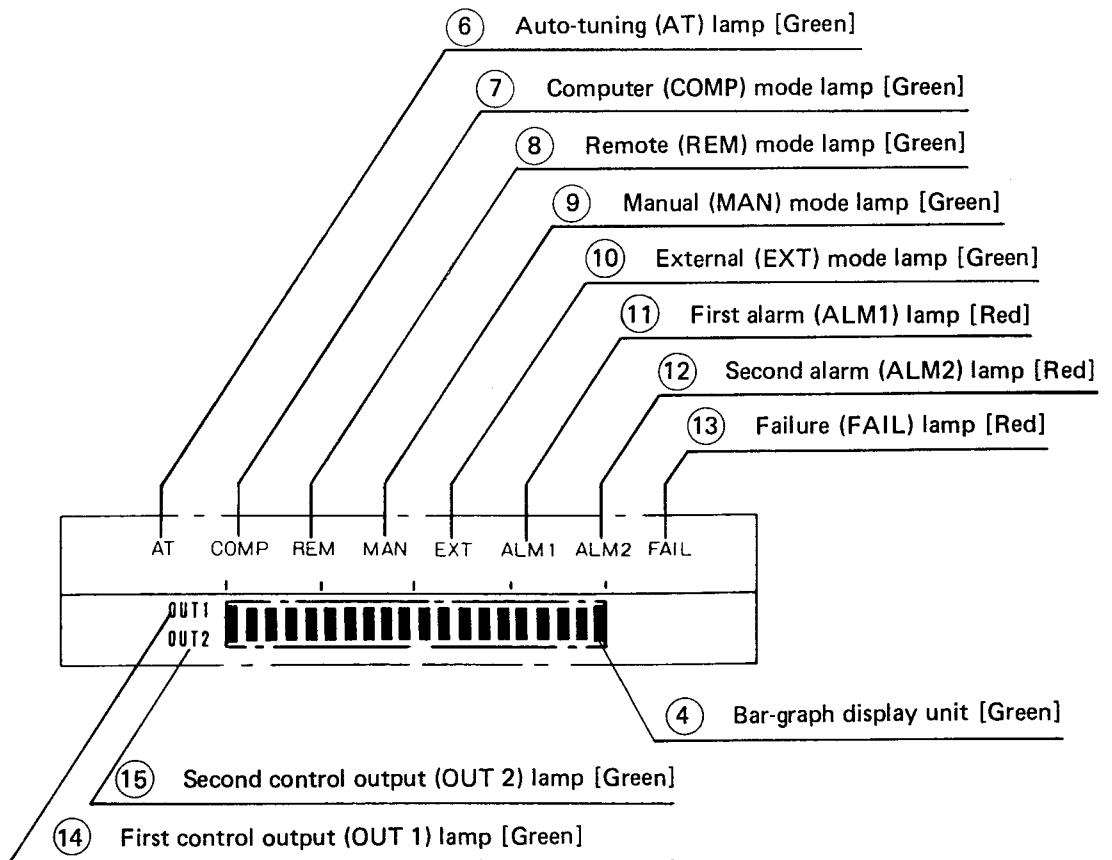
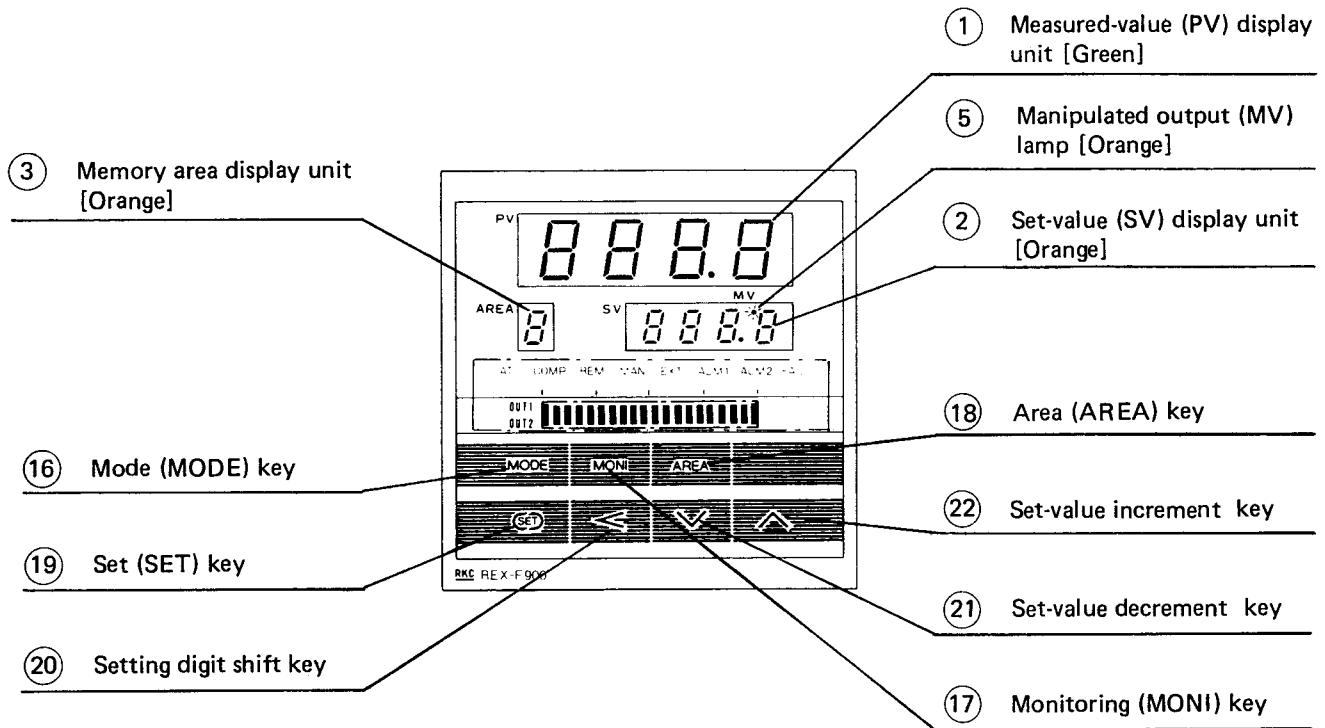

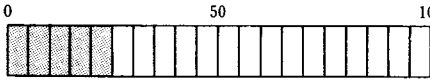
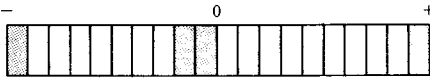
	Name	Details	
Display unit	① Measured-value (PV) display unit	<ul style="list-style-type: none"> Displays measured-value (PV). Displays various characters depending on the instrument status. 	
	② Set-value (SV) display unit	<ul style="list-style-type: none"> Displays set-value (SV). Displays each parameter set-value. Displays input value, output value and various characters depending on the instrument status. 	
	③ Memory area display unit	<ul style="list-style-type: none"> Displays memory area No. used for control. Displays memory area No. at which the setting is changed for operator level 1 and 2. 	
	④ Bar-graph display unit	<ul style="list-style-type: none"> [Manipulated output value (MV) display] When manipulated output value (MV) becomes 0% or less, the dot at the left end of the bar-graph only flashes and when it exceeds 100%, that at the right end flashes. Further feedback resistance input is displayed for position proportioning control. [Example of display]  [Deviation display] The dots at both ends of bar-graph light to indicate deviation display. [Example of display]  	
Indication lamps	⑤ Manipulated output (MV) lamp	<ul style="list-style-type: none"> Flashes when manipulated output value (MV) is displayed on the set-value (SV) display unit. 	
	⑥ Auto-tuning (AT) lamp	<ul style="list-style-type: none"> Flashes during auto-tuning execution. 	
	⑦ Computer (COMP) mode lamp	<ul style="list-style-type: none"> Lights in the computer mode (during communication). 	
	⑧ Remote (REM) mode lamp	<ul style="list-style-type: none"> Lights in the remote mode. 	
	⑨ Manual (MAN) mode lamp	<ul style="list-style-type: none"> Lights in the manual mode. 	
	⑩ External (EXT) mode lamp	<ul style="list-style-type: none"> Lights in the external mode (at control area external selection). 	
	⑪ First alarm (ALM1) lamp	<ul style="list-style-type: none"> Lights with the first alarm turned ON. 	
	⑫ Second alarm (ALM2) lamp	<ul style="list-style-type: none"> Lights with the second alarm turned ON. When heater break alarm (HBA) is selected as the second alarm, this lamp lights at heater break. 	
	⑬ Failure (FAIL) lamp	<ul style="list-style-type: none"> Lights in the fail status. 	
	⑭ First control output (OUT 1) lamp	<ul style="list-style-type: none"> Lights with the first control output turned ON. (Heating/cooling PID action type: Heating-side) (Position proportioning PID action type: Open-side) 	
	⑮ Second control output (OUT 2) lamp	<ul style="list-style-type: none"> Lights with the second control output turned ON. (Heating/cooling PID action type: Cooling-side) (Position proportioning PID action type: Closed-side) 	
	Operation key	⑯ Mode (MODE) key	<ul style="list-style-type: none"> Used when the instrument is set to the mode status and each display is selected in the mode status.
		⑰ Monitoring (MONI) key	<ul style="list-style-type: none"> Used when the instrument is set to the monitoring status and each monitoring display is selected.
		⑱ Area (AREA) key	<ul style="list-style-type: none"> Used when the instrument is set to the area status.
		⑲ Set (SET) key	<ul style="list-style-type: none"> Used when the instrument is set to the set status (Operator level 1, operator level 2 and engineer level).
⑳ Setting digit shift key		<ul style="list-style-type: none"> Used when the cursor (brightly lit) is moved to the digit whose numeric value needs to be changed for set-value change. 	
㉑ Set-value decrement key		<ul style="list-style-type: none"> Used when the numeric value needs to be decreased for set-value change. Used for operation mode transfer in the mode status. 	
㉒ Set-value increment key		<ul style="list-style-type: none"> Used when the numeric value needs to be increased for set-value change. Used for operation mode transfer in the mode status. 	

2. OPERATION

2.1 Calling-up procedure of each status

Broadly, the following four statuses are available for this instrument.

- Monitoring (MONI) status : Status in which each input/output monitoring and checking are performed
- Set (SET) status : Status in which set-value (SV) and various parameters are set and checked
- Area (AREA) status : Status in which the memory area used for control (control area) is transferred
- Mode (MODE) status : Status in which each operation mode is transferred

The calling-up procedure of each status is shown in the following.

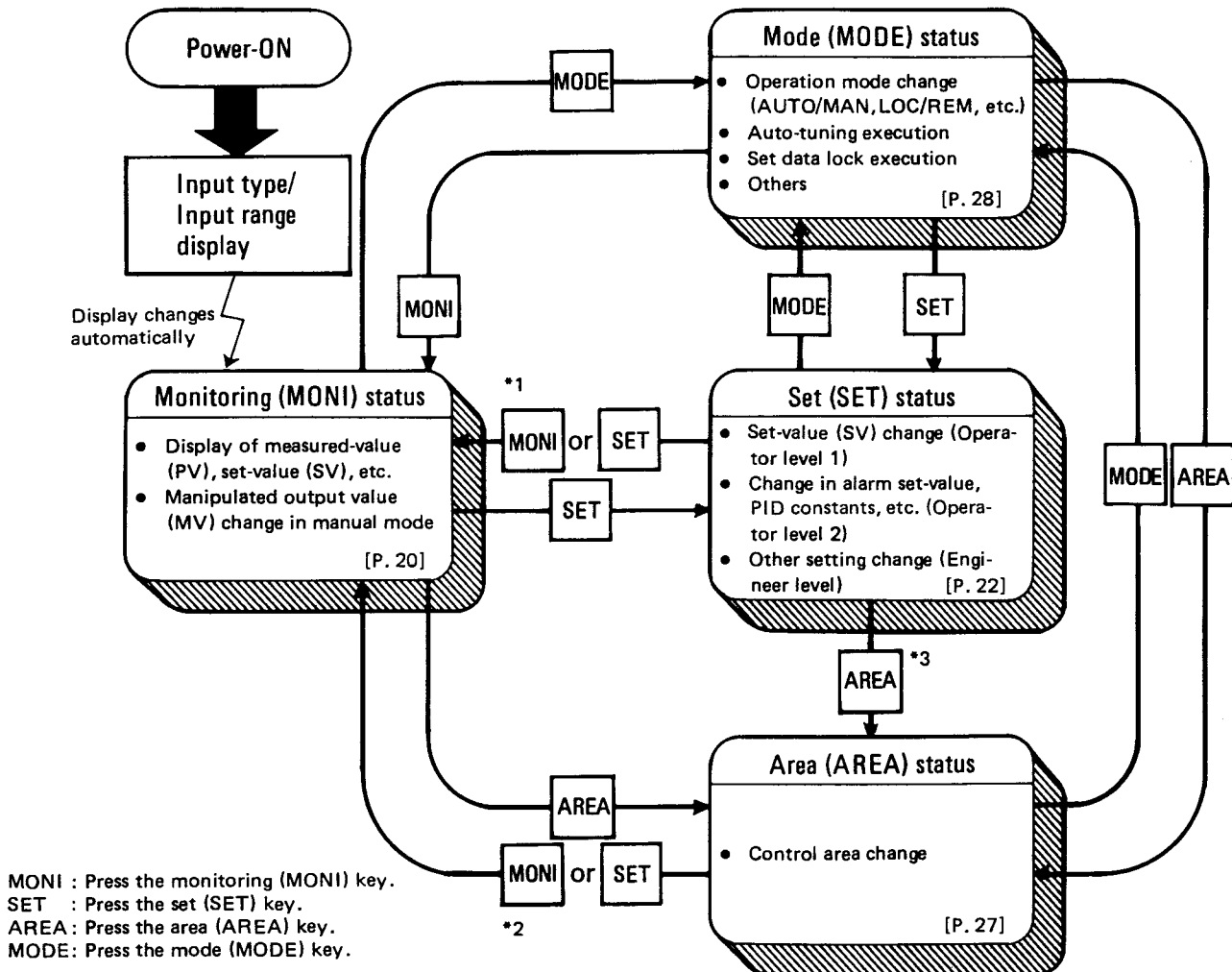

*1 For transfer from the SET status to the MONI status, basically press the MONI key. However, if the instrument is set to the operator level 1 in the SET status, it is set to the MONI status even if the SET key is pressed.

*2 When the control area is changed in the AREA status, the instrument is set to the MONI status automatically. Also, when the control area is not changed, the instrument is set to the MONI status even if either the MONI or SET key is pressed.

*3 It is impossible to set the SET status directly from the AREA status.

Caution

The instrument is set to the MONI status automatically if key operation is not performed for more than 1 min.

■ Input type/input range display

This instrument immediately confirms input type and range following power-ON.

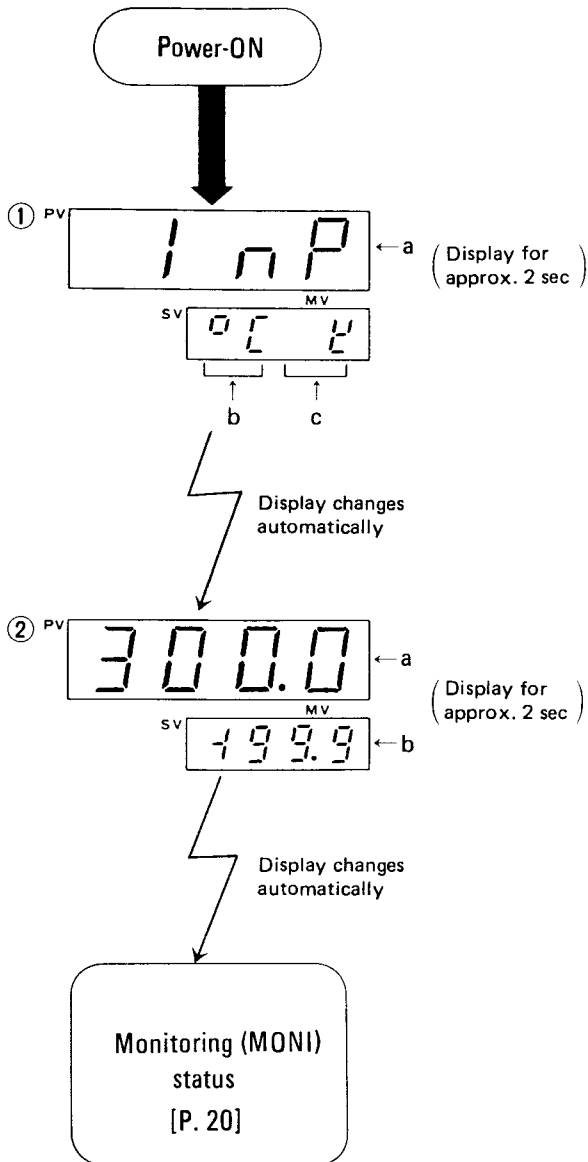

① Input type display (Display for approx. 2 sec)

a: Input display character (InP)

b: Unit

Display	Unit
0C	°C
0F	°F
None	%

c: Input type

Display	Input type	
K	TC	K
J		J
R		R
S		S
B		B
E		E
T		T
N		N
PL II		PL II
W5Re/W26Re		W5Re/W26Re
U		U
L		L
JP	RTD	JPt100
Pt		Pt 100
V	Voltage input	
I	Current input	

② Input range display (Display for approx. 2 sec)

a: High input range limit value

b: Low input range limit value

2.2 Monitoring (MONI) status

This is the status to monitor and check each input/output. Each monitoring display is shown in the following. Display in the MONI status is changed by the MONI key.

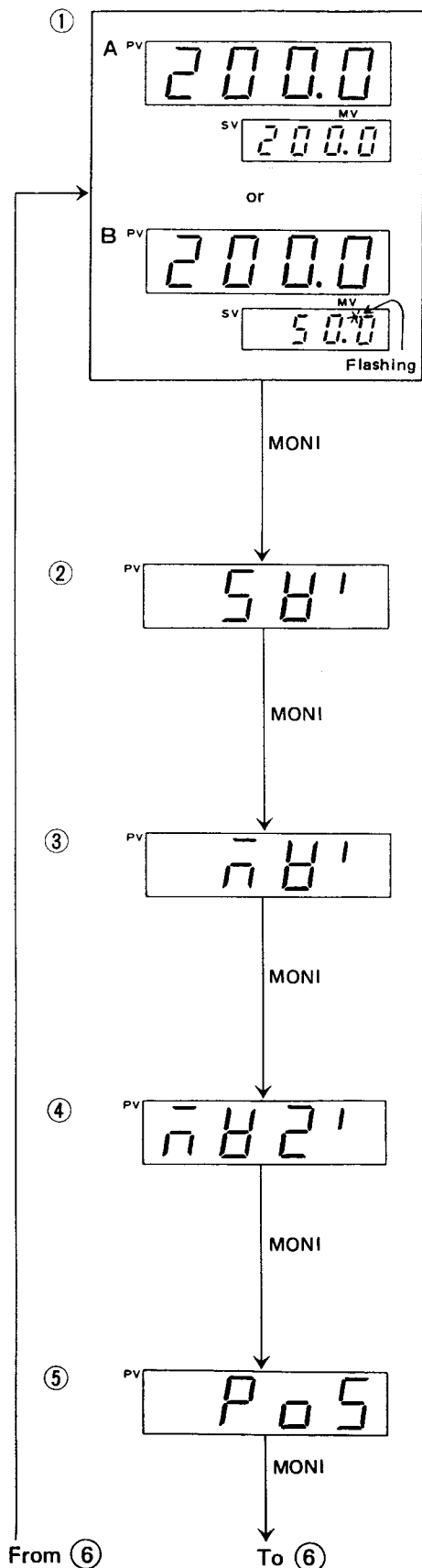

A. Measured-value (PV)/set-value (SV) displays

[Displayed during auto (AUTO) mode operation]

The measured-value (PV) display unit displays the current measured-value (PV), and the set-value (SV) display unit displays desired value. In the remote (REM) mode, the display unit displays the remote setting input value (RS).

Display range: Same as the input range

B. Measured-value (PV)/manipulated output value (MV) displays

[Displayed during manual (MAN) mode operation]

The measured-value (PV) display unit displays the current measured-value (PV), and the set-value (SV) display unit displays the manipulated output value (MV). At this time, the point above the manipulated output value (MV) decimal-point (between the lower first and second digits) flashes to indicate that the display unit shows the manipulated output value (MV).

Display range: Same as the input range (Measured-value (PV))
-5.0 to +105.0% (Manipulated output value (MV))

Set-value (SV) display during setting change

Display set-value (SV) which changes every moment by a setting change rate limit function when the set-value (SV) is changed. This display becomes the same as ① A set-value (SV) display with the setting change rate limit function turned OFF (Setting "0.0").

Display range: Within setting limit range

Manipulated output value (MV) display during output change

Displays manipulated output value (MV) actually output from the instrument. Therefore, when the output change rate limit function is set, displays manipulated output value (MV) via that function.

Display range: Within output limit range [%]

(For heating/cooling PID action, displays manipulated output value (MV) on the heating-side.)

Manipulated output value (MV) display during output change (Cooling-side)

[Displayed only during heating/cooling PID action]

For heating/cooling PID action, displays manipulated output value (MV) on the cooling-side.

Display range: Within output limit range [%]

Feedback resistance input value (POS) display

[Displayed only during position proportioning PID action]

Displays feedback resistance input value (POS) for position proportioning PID action.

Display range: 0.0 to 100.0%

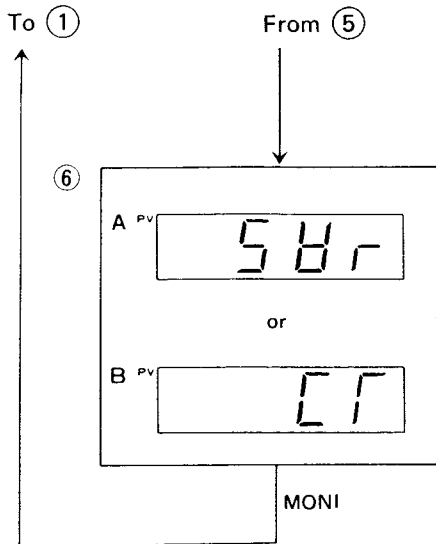

A. Remote setting input value (RS) display

[Displayed only when the remote setting input function is provided]
 Displays remote setting input value (RS) which is the controlled target value in the remote (REM) mode.

Display range: Within setting limit range

B. Current transformer input value (CT) display

[Displayed only when the heater break alarm (HBA) function is provided]
 Displays the input value of the current transformer used when the instrument is provided with the heater break alarm (HBA) function.

Display range: 0.0 to 105.0 A

Caution

① is displayed when the power is turned ON or the instrument is transferred from the other status.

■ **Manipulated output value (MV) setting in the manual (MAN) mode**

Manipulated output value (MV) in the manual (MAN) mode can be manually set in the monitoring (MONI) mode.

[Display example]

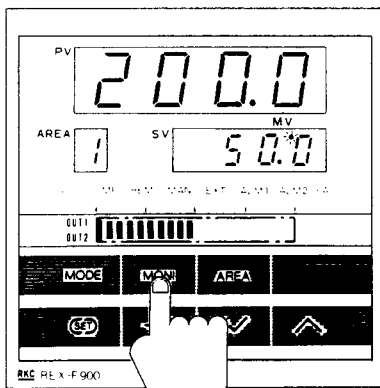



- Press the MONI key to display "Measured-value (PV)/manipulated output value (MV) displays" (① B display).
- Press the \wedge key at this time increments manipulated output value (MV) and pressing the \vee key decrements the same value. Keeping pressing the \wedge or \vee key makes numeric value change faster.

2.3 Set (SET) status

(1) Set (SET) status outline

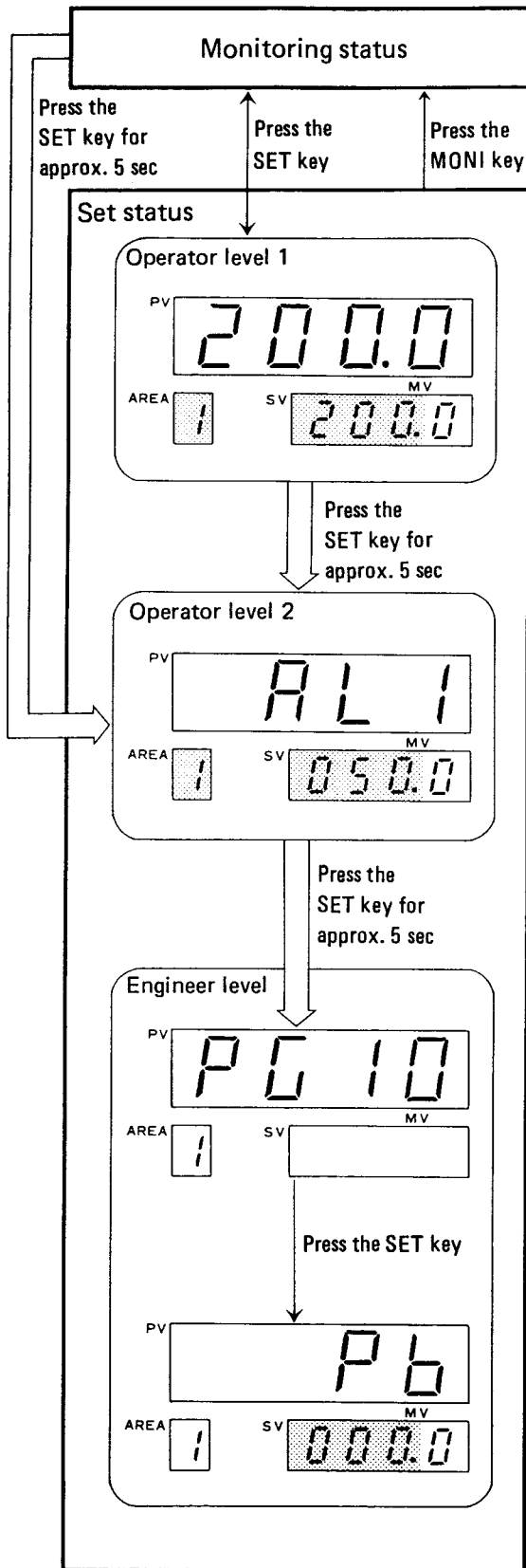
[Display flow example]



The  section indicates dim lighting.

① Operator level 1

- Pressing the SET key in the monitoring or mode status sets the instrument to the operator level 1.
- The operator level 1 enables a change in the control target set-value (SV).
- No. of memory areas: 8
(One set-value (SV): 1 memory)
- Setting range : Same as input range
- Initial value prior to shipment : 0 (Decimal-point position varies with input type.)

② Operator level 2

- Pressing the SET key for approx. 5 sec sets the instrument to the operator level 2.
- The operator level 2 enables changes in parameters such as alarm setting values, PID constants, etc.
- Pressing the SET key changes each parameter in the operator level 2 in due order.
- No. of memory areas: 8
(All operator level 2 items: 1 memory)

*For the details of the operator level 2, see "(2) Description of each parameter" on page 23.

③ Engineer level

- Pressing the SET key for approx. 5 sec in the operator level 2 status sets the instrument to the engineer level.
- The engineer level enables the setting of control action, input/output, alarm and additional function operation selection, and the presence or absence of function. Therefore, this setting is not frequently used.
- In the engineer level status, first parameter group (PG) No. is displayed. This parameter group (PG) is selected by the \wedge and \vee keys. Pressing the SET key changes each parameter in the parameter group (PG) in due order.

*For the details of the engineer level, see Chapter 3. "ENGINEER LEVEL" on page 37.

(2) Description of each parameter (Operator level 2)

Each parameter in the operator level 2 status is shown in the following. Every time the SET key is pressed, each parameter changes in the following order. (The first parameter appears after one cycle is finished.)

Symbol	Name	Setting range	Description	Initial value prior to shipment
*1 AL1	First alarm	<ul style="list-style-type: none"> • Deviation alarm High alarm, low alarm: (–span or –1999) to (+span or +9999) High and low alarm, band alarm: 0 to (+span or +9999) 	Sets the first alarm set-value.	50.0 or 500
AL1				
*2 AL2	Second alarm	<ul style="list-style-type: none"> • Process alarm Same as input range * Decimal-point position varies with input type 	Sets the second alarm set-value.	50.0, 500, –50.0 or –500
AL2				
*3 P	(Heating-side) Proportional band	0.1 to 999.9% of span ("0.0" cannot be set.)	Set when PI or PID control is performed. For heating/cooling PID action: Proportional band setting on the heating-side.	3.0
P				
*3 I	Integral time	1 to 3600 sec ("0" cannot be set.)	Eliminates offset occurring in proportional control.	240
I				
*3 d	Derivative time	0 to 3600 sec ("0" setting: Derivative action OFF)	Prevents ripples by predicting output change, thereby improving control stability.	60
d				
*3 rPT	Control response designation parameter	0: Slow 1: Medium 2: Fast	Response required due to set-point change in PID control is specified.	0
rPT				
*4 PC	Cooling-side proportional band	0.1 to 999.9% of span ("0.0" cannot be set.)	Sets cooling-side proportional band when heating/cooling PID action is performed.	3.0
PC				
*4 db	Deadband	–10.0 to +10.0% of span	Sets control deadband between heating-side and cooling-side proportional bands. Minus (–) setting results in overlap.	0.0
db				
*4 SVrL	Setting change rate limit	0.0 to 100.0%/min of span ("0.0" setting: Setting change rate limit OFF)	Setting amount of set-value (SV) change per one minute when the set-value (SV) is change.	0.0
SVrL				

*1 Does not display when no alarm is provided and/or FAIL is selected for the first alarm.

*2 Does not display when no alarm is provided, there is only one alarm output, FAIL is selected for the second alarm and/or heater break alarm function is provided.

*3 No display is made for ON/OFF action.

*4 Displayed only for heating/cooling PID action.

(3) Setting change procedure

(a) When set-value (SV) is changed

[Example] When the set-value (SV) is changed to 200.0°C

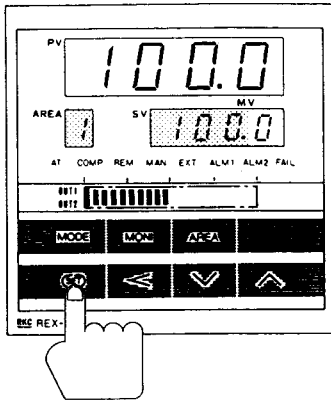

① Set the instrument to the operator level 1 status.

Press the SET key to set the instrument to the operator level 1 status. The least significant digit on the set-value (SV) display unit lights up brightly, and other digits and the memory area display unit light up dimly. The brightly lit digit can be set.

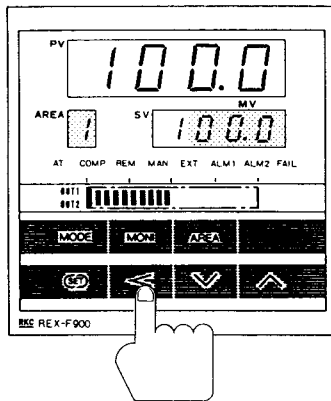

② Shift of brightly lit digit

Press the < key to move the brightly lit digit up to the most significant digit. Every time the < key is pressed, each brightly lit digit moves as follows.

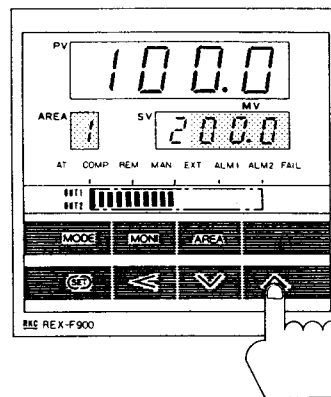
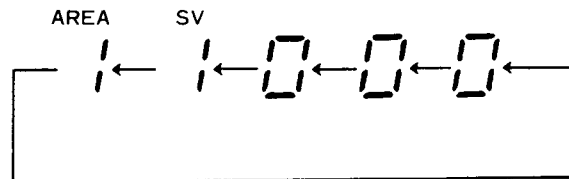

③ Numeric value change

Press the ^ key to set "2".

Pressing the ^ key increments numeric value, and pressing the v key decrements the value.

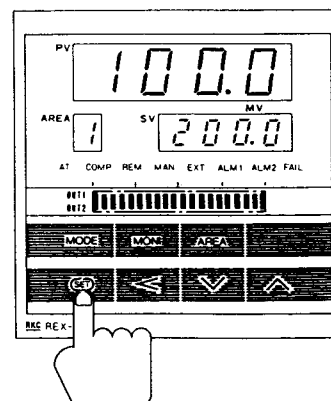

④ Set-value (SV) registration

After the displayed value is changed, press the SET key.

All digits corresponding to set-value and memory area No. display are brightly lit. Thus, the instrument is set to the monitoring status to register the set-value.

(b) When another area set-value (SV) is changed without changing control area

[Example] When memory area No. 2 set-value (SV) is changed to 100.0°C with control area set to memory area No.1

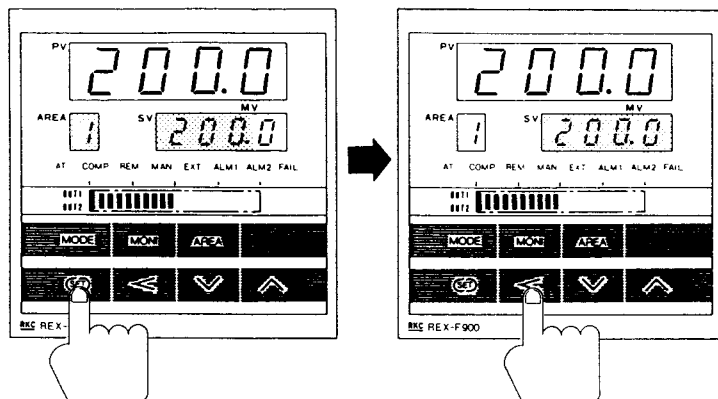

- ①
- Press the SET key to set the instrument to the operator level 1.
 - Press the < key to move the brightly lit digit up to the memory area No. display.

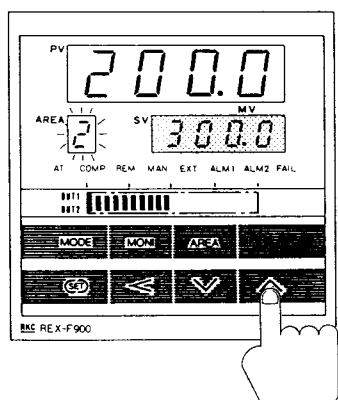

- ②
- Press the ▲ key to set memory area No. to "2". The set-value (SV) display unit displays memory area No. 2 set-value (SV). Also, the memory area No. display flashes in order to indicate that the memory area now displayed differs from the control area.

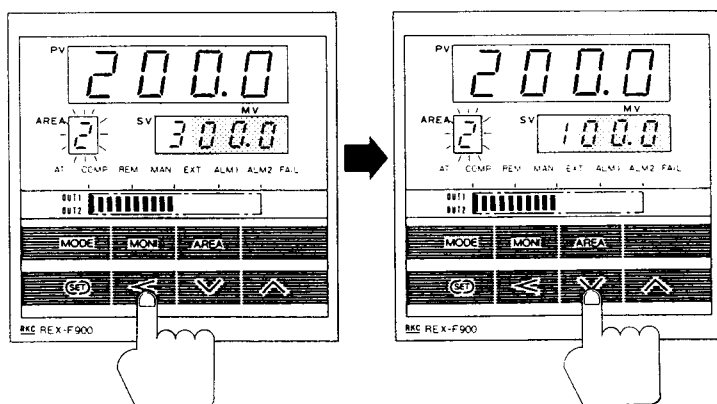

- ③
- Press the < key again to move the brightly lit digit up to the most significant digit.
 - Press the ▼ key to set the digit to "1".

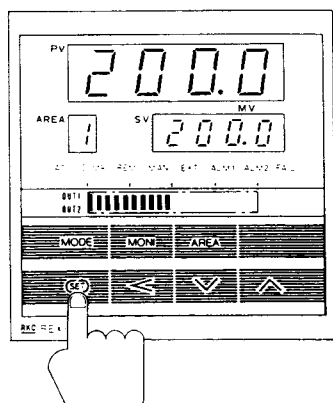

- ④
- After the displayed value is changed, press the SET key. Thus, instrument status changes to the monitoring status and also the display is for the control area. At this time, the changed memory area No. 2 set-value (SV) is registered.

- (c) When each parameter set-value (SV) is changed
[Example]

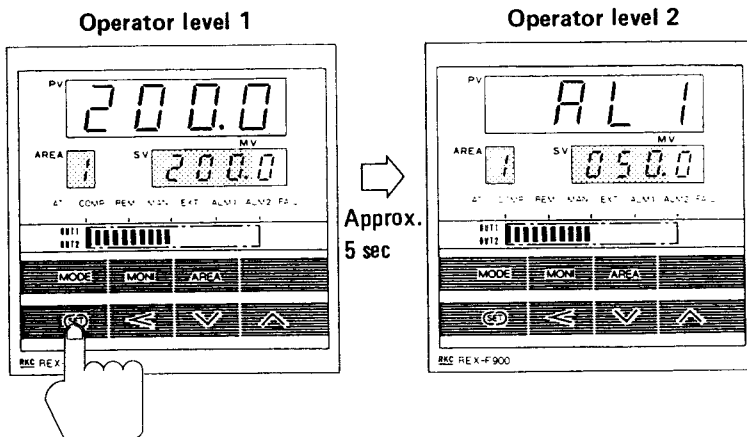

- Press the SET key for approx. 5 sec to set the instrument to the operator level 2.
 - Press the SET key once each time until the parameter symbol whose setting needs to be changed is displayed.
 - In the same way as in items ② to ④ on page 24, change the setting.
- For the operator level 2, pressing the SET key at the time of setting registration moves the display to the next parameter.

- (d) When parameter set-value in another area is changed without changing control area

- Press the SET key for approx. 5 sec to set the instrument to the operator level 2.
- Press the SET key once each time to display the parameter symbol whose setting needs to be changed.
- In the same way as in item (b) on page 25, display the memory area No. to be changed to change the set-value.
- After the displayed value is changed, pressing the SET key registers the changed value and moves the display to the next parameter.

However, the memory area No. remains with the status changed (memory area No. display flashing). Press the MONI key when the display needs to be returned to the control area display.

* The following is also available when changing the set-value

Set-value increase or decrease Example: When a temperature of 199°C is changed to 200°C.

Press the ◀ key to shift the digit brightly lit to the least significant digit. Press the ▲ key to change "9" to "0", thereby obtaining 200°C. The same applies to set-value decrease.

Minus (-) value setting Example: For changing 200 to -100.

Press the ◀ key to shift the digit brightly lit to the hundreds digit. Press the ▼ key to decrement figures in order of 1 → 0 → -1.

Key operation cautions

- This instrument cannot register the setting just changed. The value can be registered for the first time after it is changed and then the SET key is pressed.
- If the instrument is not set to the operator level 1 even when the SET key is pressed or the set-value does not light brightly or dimly even when set to the operator level 2, the set data lock may be activated. In this case press the MODE key to set the instrument to the mode status to confirm whether the instrument is set to the unlock status by "Set data unlock/lock transfer" (See page 28).
- This instrument returns to the monitoring status automatically if key operation is not performed for more than 1 min.

2.4 Area (AREA) status

The AREA status is for changing memory area used for control (control area). Control area changing procedure is described in the following.

[Example] When the control area is changed from memory area No.1 to No. 2.

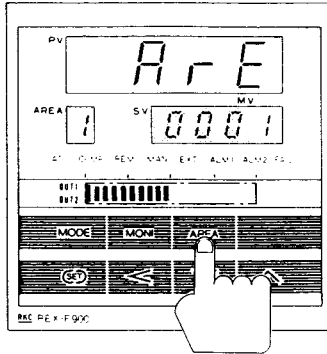

- ① Press the AREA key to set the instrument to the AREA status. The measured-value (PV) display unit displays "ArE" (ArE) to indicate that the instrument is in the AREA status. The set-value (SV) display unit also shows control area No.

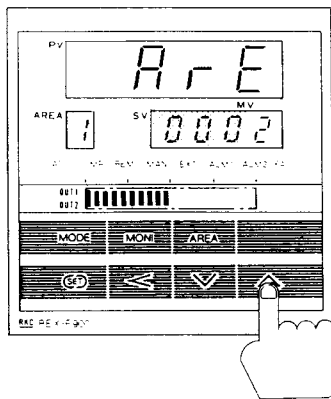

- ② Press the \blacktriangle key to display "2" on the set-value (SV) display unit. At this time, the control area is not as yet changed. The No. displayed on the memory area display unit corresponds to the control area.

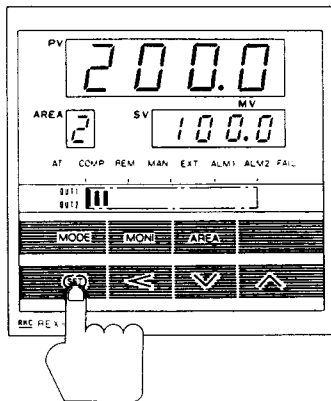

- ③ Press the SET key to change the control area. The instrument is set to the monitoring status.

Caution

This instrument returns to the monitoring status automatically if key operation is not performed for more than 1 min.

2.5 Mode (MODE) status

(1) Display flowsheet

The MODE status is for each operation mode transfer, a display flowsheet in the MODE status is shown in the following. Display in the MODE status is changed by the MODE key.

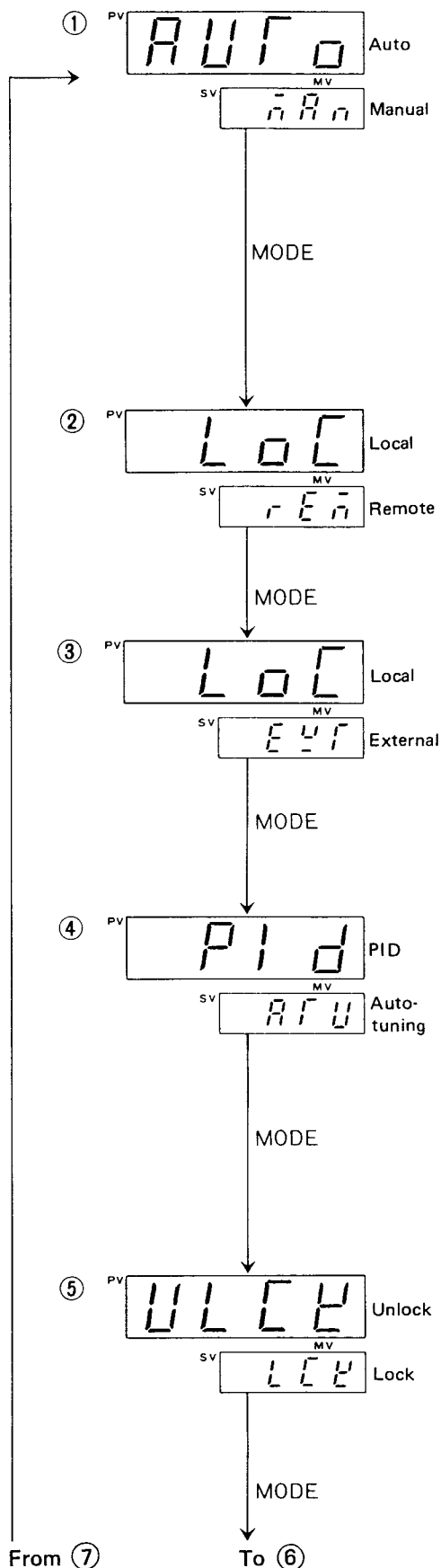

Auto (AUTO)/manual (MAN) transfer

[Displayed only when the manual mode is provided]

Selected when control is performed in either the automatic or manual mode.

*The manual mode is provided for the following cases:

- For PID action with auto-tuning (F), and voltage input or current input.
- For position proportioning PID action

*The manual setting of manipulated output value (MV) in the manual mode is made in the monitoring status (See page 20).

Local (LOC)/remote (REM) transfer

[Display only when the instrument is provided with the remote setting input function]

Selected when either data within the instrument (local) is used as set-value (SV) or external (remote) setting input data is used.

Control area internal (local)/external transfer

[Displayed only when the instrument is provided with the control area contact input transfer function]

Selected when control area is transferred either by key operation (local) or contact input (external).

* For contact input, see 2.6 Contact input usage (Page 31).

PID/auto-tuning (AT) transfer

[Displayed only when the instrument is provided with the auto-tuning (AT) function]

Selected when either PID control or auto-tuning (AT) is performed. The selection of auto-tuning immediately starts the auto-tuning function. After this function is completed, the controller is transferred automatically to PID action.

Set data unlock/lock transfer

Selected when either the set data lock function is invalidated (unlock) or validated (lock).

*Details of set data lock are set by engineer level in set status (See Chapter 3. "ENGINEER LEVEL" on page 37).

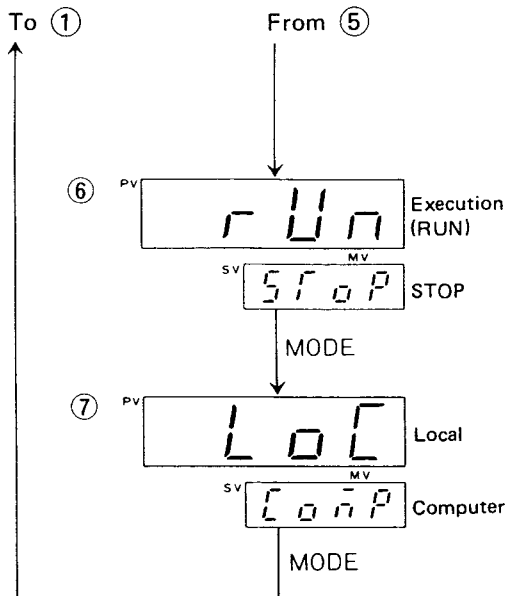

Operation execution (RUN)/STOP transfer

Selected when operation is either executed (RUN) or stopped (STOP).
 *When set to STOP, the set-value (SV) display unit shows "S T O P" in the monitoring status.

*If the instrument is transferred to execution (RUN) from STOP, it performs the same operation as the power-ON.

Local (LOC)/computer (COMP) transfer

[Displayed only when the instrument is provided with the communication function]

Selected when either control by key operation (local) is performed or control via communication (computer) is performed.

Cautions

1. Normally, when the instrument is set to the MODE status, first ① is displayed, but ⑦ is first displayed when control via communication is performed. Also ⑥ is first displayed in the operation STOP status.
2. This instrument returns to the monitoring status automatically if key operation is not performed for more than 1 min.

(2) Operation mode transfer procedure

[Example] When operation is changed from execution (RUN) to STOP

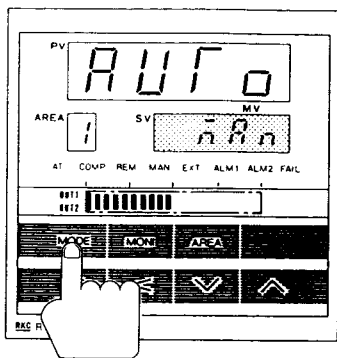

- ① Press the MODE key to set the instrument to the MODE status.
Usually, "AUTO/MAN transfer" is displayed first, but during communication "LOC/COMP transfer" is displayed first.

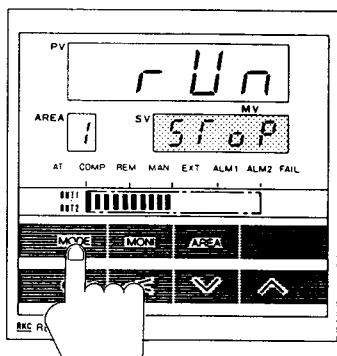

- ② Press the MODE key to display "Operation execution (RUN)/STOP transfer".
The display selected is brightly lit.

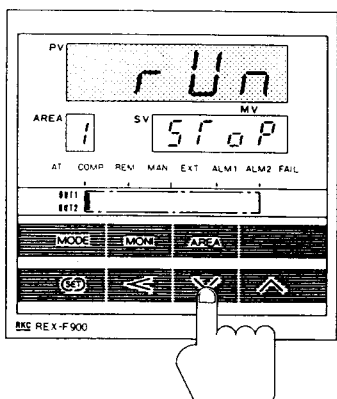

- ③ Press the \blacktriangledown key to change the instrument from RUN to STOP.
For operation mode transfer, mode transfer becomes valid at this time. Press the \blacktriangle key changes the display on the set-value (SV) display unit to that on the measured-value (PV) display unit. Pressing the \blacktriangledown key changes the above display unit in reverse order.

*If the instrument is transferred to RUN from STOP, it performs the same operation (see page 19) as the power-ON.

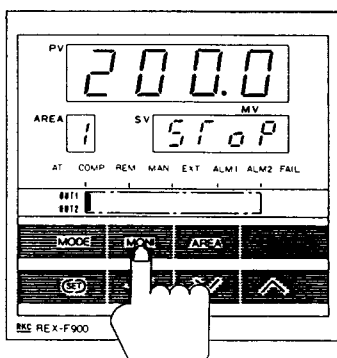

- ④ After the above transfer is finished, press any key of MONI, SET and AREA to set the instrument to the desired status. (The figure at left shows the monitoring status.)

2.6 Contact input usage

In this instrument, the control area and each operation mode can be transferred by the front keys and also by contact input. (Optional)

(1) Control area transfer

The control area can be transferred according to the open/close status of rear terminals Nos. 22 to 25.

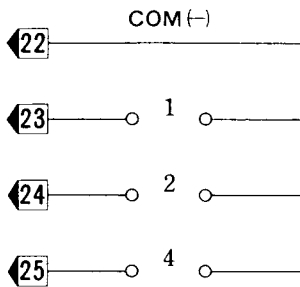

● Control area transfer according to rear terminal open/close status

Control area Terminal	1	2	3	4	5	6	7	8
No. 22-23	-	×	-	×	-	×	-	×
No. 22-24	-	-	×	×	-	-	×	×
No. 22-25	-	-	-	-	×	×	×	×

- : Open × : Closed

Cautions

- When the control area is transferred by contact input, set the instrument to the external mode (*EXT*) according to the MODE status "Control area internal (local)/external transfer" (see page 28).
- In this instrument, the control area is transferred approx. 2 sec after the rear terminal (Nos. 22 to 25) open/close status is changed.

(2) Operation mode transfer

The operation mode can be transferred according to the open/close status of the rear terminal Nos. 12 and 13.

The operation mode transferred by contact input is any one of AUTO/MAN, LOC/REM and LOC/COMP.

(To be specified when ordering)

The operation mode transfer status by contact input is shown in the following.

	Front key mode selection	Status of rear terminal Nos. 12 and 13	Actual operation mode	Lamp status	
				Lamp	Status
Auto/manual transfer	Auto	Closed	Auto	MAN Manual mode lamp	OFF
		Open	Manual		Flashing
	Manual	*		MAN	ON
Local/remote transfer	Remote	Closed	Remote	REM Remote mode lamp	ON
		Open	Local		Flashing
	Local	*			OFF
Local/computer transfer	Computer	Closed	Computer	COMP Computer mode lamp	ON
		Open	Local		Flashing
	Local	*			OFF

* The open or close status of rear terminal Nos. 12 and 13 is acceptable.

Caution

In this instrument, the operation mode is transferred approx. 1 sec after the rear terminal (Nos. 12 and 13) open/close status is changed.

2.7 Feedback resistance adjustment

Prior to shipment, this instrument has already been adjusted so as to match feedback resistance specified by the customer. However for its more accurate control, adjust it according to the following. When this instrument adjusting, confirm that the wiring is correct and control motor load is activated.

First connect wiring as shown in the following:

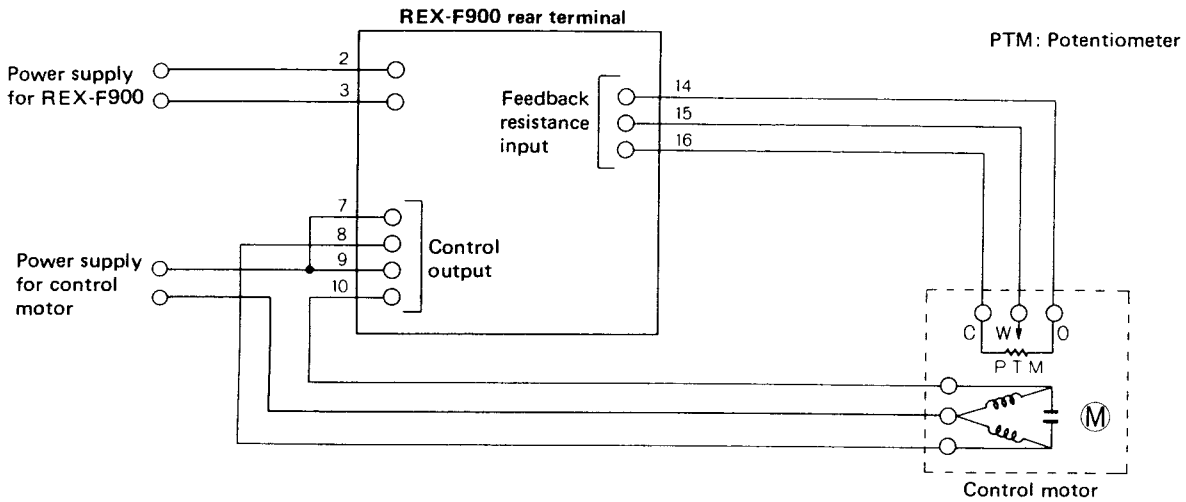

Next, perform operations in accordance with the following flowsheet:

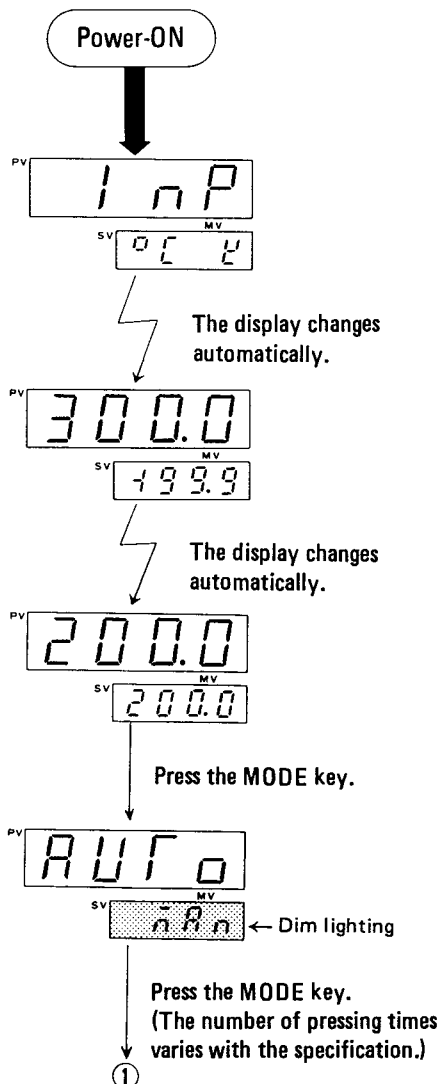

- Input type display**
 The Figure at the left is for thermocouple input K and unit °C.
- Input range display**
 The Figure at the left is for the range of -199.9 to +300.0.
- Monitoring status**
 The Figure at the left is for measured-value (PV)/set-value (SV) display.
- Mode status**
 The Figure at the left is for auto/manual transfer display.

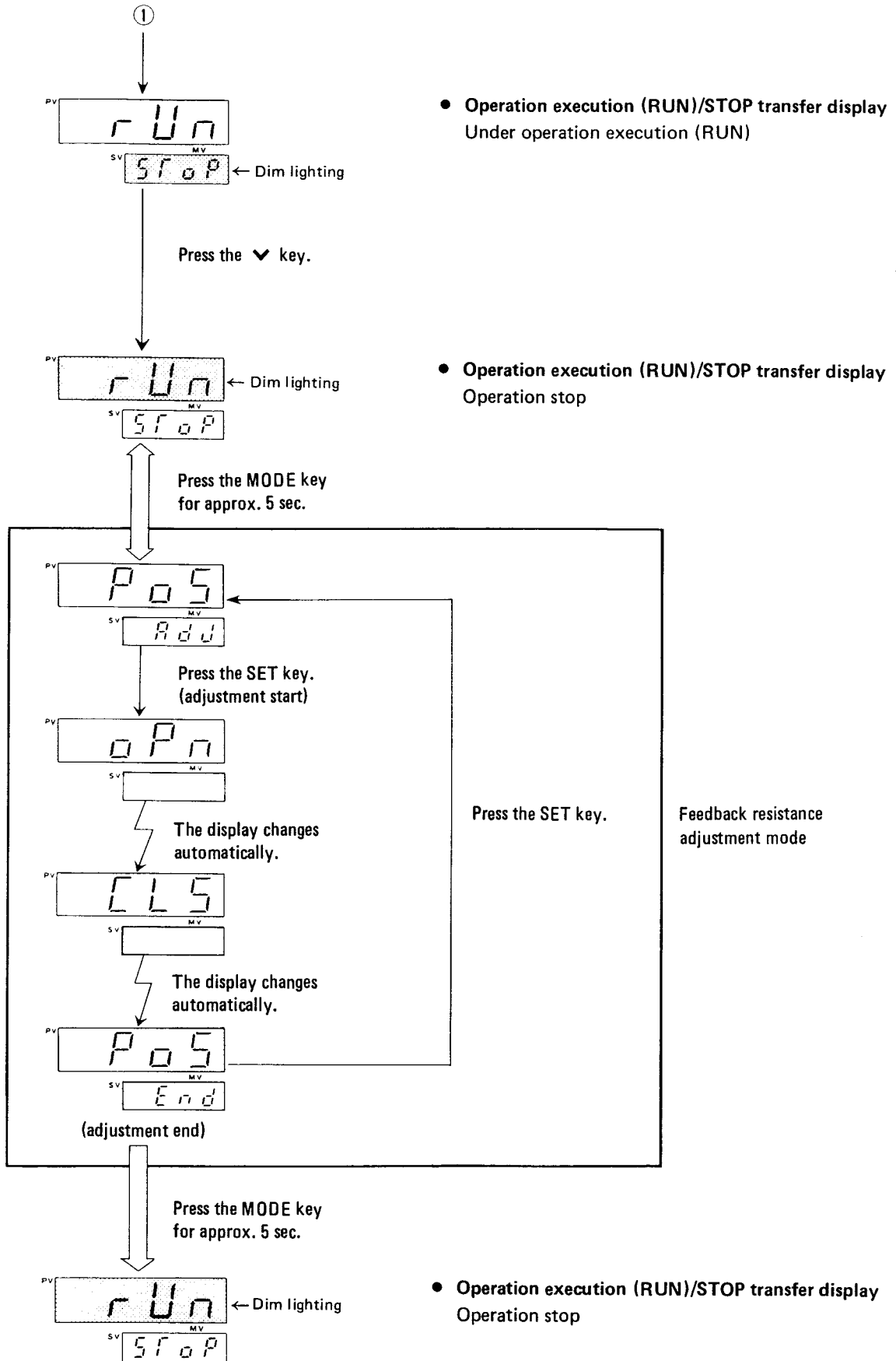

3. CAUTIONS FOR OPERATION

3.1 Operation execution (RUN)/STOP

Since there is no power switch on this instrument, the instrument starts operation immediately following initial power-ON.* However, there are some setting items which cause inconvenience when changed during RUN. For these settings, stop instrument operation at "Operation execution (RUN)/STOP transfer" (see page 29) in the MODE status.

Since parameters which are set in the operation STOP status belong to the engineer level in the SET status, see Chapter 3. "ENGINEER LEVEL" (Page 37) for details.

The start status when executed from operation stop becomes that selected in "3.3 (1) Hot/cold start selection" (Page 36).

*"Operation execution (RUN)/STOP transfer" prior to shipment is set to "execution (RUN)".

■ Operation under operation execution (RUN)

- For needing a change in the details of display in the monitoring status, see "2.2 Monitoring (MONI) status" (Page 20).
- When needing a change in the set-value (SV) or each parameter, see "2.3 Set (SET) status" (Page 22).
Also if any parameter to be changed is in the engineer level, refer to the Chapter 3. "ENGINEER LEVEL" (Page 37) in addition to the above section.
- When needing a change in the control area, see "2.4 Area (AREA) status" (Page 27).
- When needing a change in the operation mode, see "2.5 Mode (MODE) status" (Page 28).
- When needing control area transfer by contact input or operation mode transfer, see "2.6 Contact input usage" (Page 31).
- When needing activation of the auto-tuning (AT) function, see "3.2 Requirements for auto-tuning (AT)" (Page 35).

*For calling of each status, see "2.1 Calling-up procedure of each status" (Page 18).

■ Cautions at operation stop (STOP)

- In the monitoring status, the measured-value (PV) display unit shows measured-value (PV). Also the set-value (SV) display unit, "STOP" (STOP).
- When "No operation execution/stop display" is set by PG40 (see Chapter 3. "ENGINEER LEVEL" on page 37) in the engineer level status, the "Operation execution (RUN)/STOP selection" display panel is not displayed even with the MODE key pressed.

3.2 Requirements for auto-tuning (AT)

Auto-tuning (AT) is the function of measuring, computing and setting the optimum PID constants.

The requirements for auto-tuning (AT) start and suspension are described in the following.

Auto-tuning (AT) is started/stopped by "PID/auto-tuning (AT) transfer" in the mode status (See page 28).

(1) Requirements for auto-tuning (AT) start

Start auto-tuning (AT) when all the following conditions are satisfied:

- ① In the MODE status
 - AUTO/MAN transfer → Auto mode
 - LOC/REM transfer → Local mode
 - PID/auto-tuning (AT) transfer → PID control
 - Operation execution (RUN)/STOP transfer → execution (RUN)
- ② Input value should not be abnormal. (According to the input abnormality determination point)
- ③ The high output limiter value should be 0.1% or more and the low output limiter value, 99.9% or less

(2) Requirements for auto-tuning (AT) suspension

- When set-value (SV) is changed
- When the control area is changed
- When high or low output limiter value is changed
- When PV bias and/or PV digital filter are changed
- When AT bias is changed
- When the instrument is transferred to the manual mode by "AUTO/MAN transfer"
- When the instrument is transferred to the remote mode by "LOC/REM transfer"
- When the instrument is transferred to PID control by "PID/AT transfer"
- When operation is stopped by "Operation execution (RUN)/STOP transfer"
- When input value becomes abnormal. (According to the input abnormality determination point)
- When power failure occurs
- When the instrument is in the FAIL status

Cautions

1. When auto-tuning (AT) suspension requirements are established, the instrument immediately suspends auto-tuning (AT) function to transfer the above function to PID control. PID constants at that time are left as they were before auto-tuning (AT) start.
2. If the output change late limit (see Chapter 3. "ENGINEER LEVEL" on page 37) is set, the optimum PID constants may not be obtained even with the auto-tuning (AT) function activated.

3.3 Action during power failure

(1) Hot/cold start selection

Instrument action is not influenced by instantaneous power failure. Also power recovery action after extended power failure can be selected from the following 3 items. Selection is made in the engineer level (See Chapter 3. "ENGINEER LEVEL" on page 37).

	Operation mode at power recovery	Output value at power recovery	
Hot start 1	Same as that before power failure	Same as that before power failure	
Hot start 2	Same as that before power failure	MAN mode	Low output limiter value
		AUTO mode	Value as a result of * control computation
Cold start	MAN mode	Low output limiter value	

* The result of control computation varies with the control designation parameter. (For setting status and operator level 2, see page 23.)

(2) Start determination point setting

Apart from hot/cold start selection, a start determination point is set for the above start. Start determination point becomes set-value (SV) deviation setting.

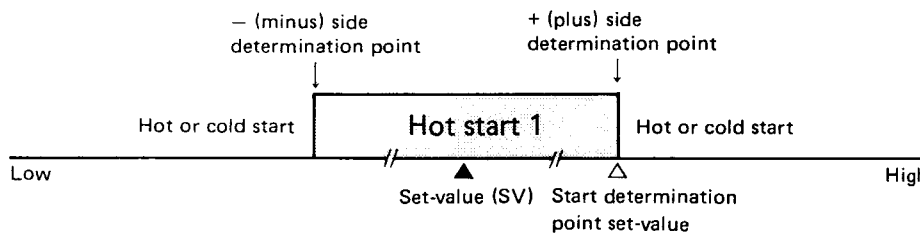

The start status is determined according to the measured-value (PV) level (deviation from set-value (SV)) at power recovery. When the measured-value (PV) is between the + (plus) and - (minus) side determination points, start power recovery always becomes "Hot start 1". When the measured-value (PV) is outside the determination points, operation starts in the start status selected by hot/cold start selection.

The start determination point is set by the engineer level in the setting status (See Chapter 3. "ENGINEER LEVEL" on page 37).

Cautions

1. Even when the instrument is transferred from operation STOP to RUN, the same start as that at the time of power recovery is attained.
2. No cold start can be selected when there is no manual mode.
3. In this instrument, instantaneous power failure action is guaranteed for power failure of 50 msec or less.

Chapter 3 ENGINEER LEVEL

1. OVERVIEW OF ENGINEER LEVEL

Engineer level is one of setting levels in the set status and in this level parameters not frequently changed under normal operation are collected. In addition a parameter group (PG) is formed for each related parameter.

1.1 Engineer level calling procedure

[Example] Calling from monitoring status

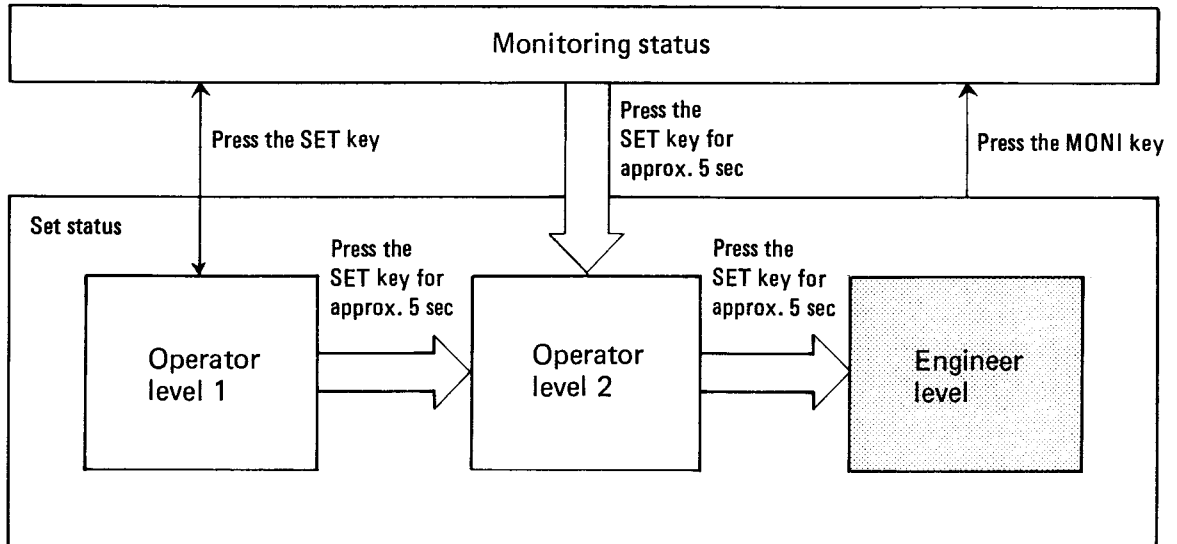

*For calling in any status other than the monitoring status, see Chapter 2, "2.1 Calling-up procedure in each status" (Page 18).

1.2 Parameter list

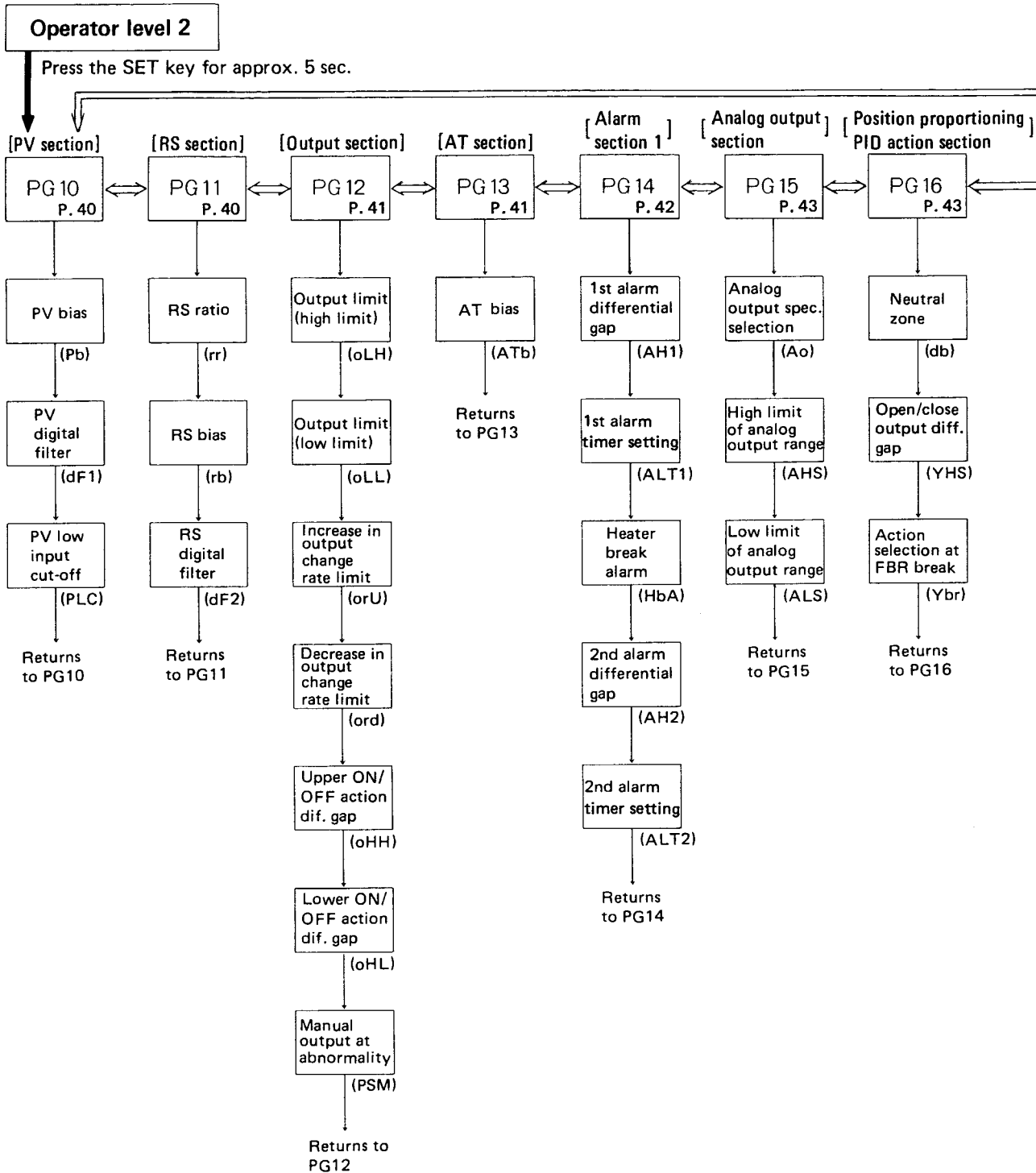

Cautions

1. There may be items not displayed depending on the specification.
2. Numeric value setting procedure is the same as Chapter 2, "2.3 (3) Setting change procedure" (Page 24).
3. Parameters from PG20 to PG24 can be changed only when the instrument is set to the STOP status by "Operation execution (RUN)/STOP transfer" in the MODE status. (Within)

↓ : Press the SET key
 ⇔ : Press the ▲ key or ▼ key
 PG : Means parameter group

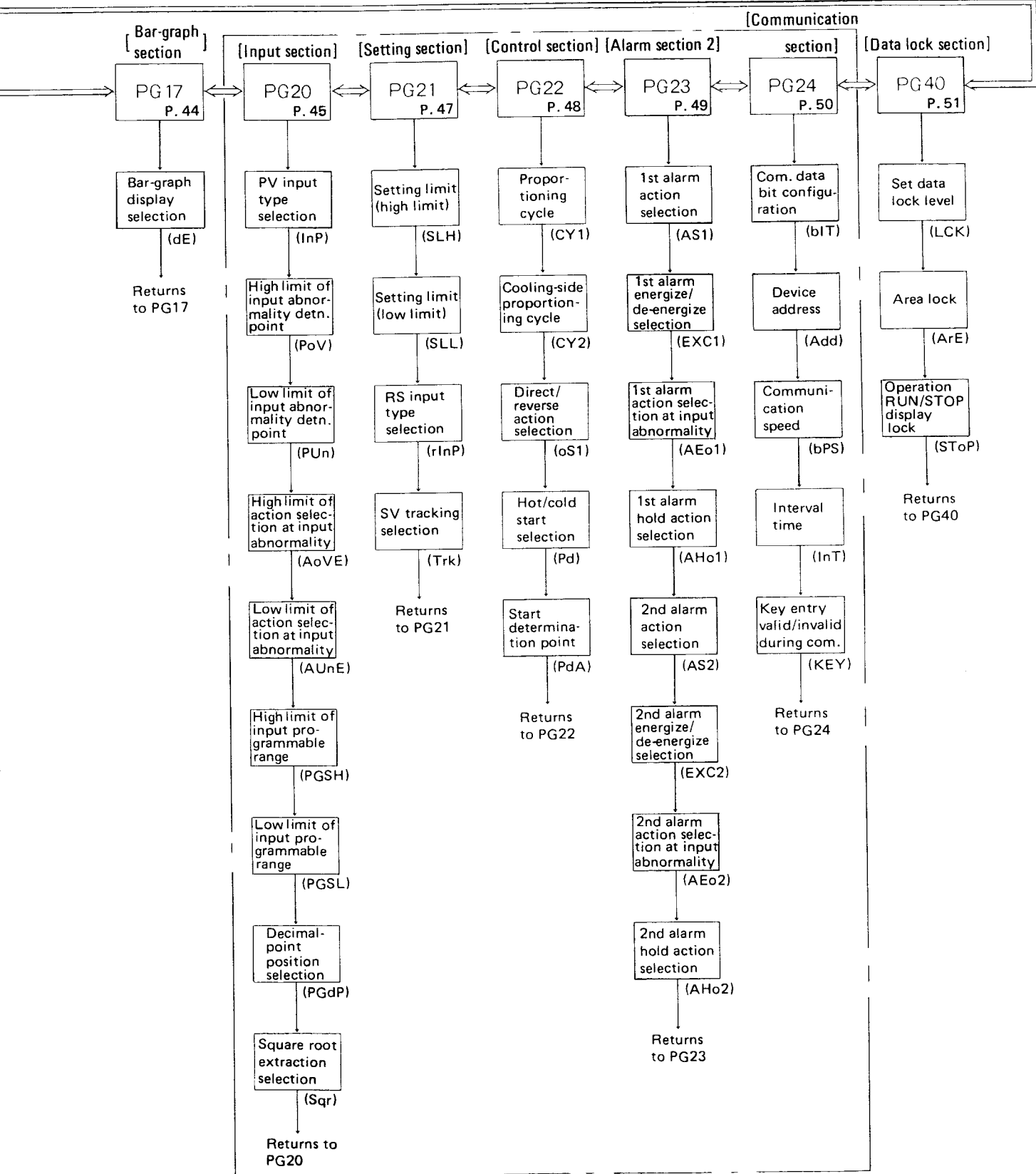

2. DESCRIPTION OF EACH PARAMETER

2.1 PV (measured-value) section [Parameter group (PG) 10]

Symbol	Name	Setting range	Description	Initial value prior to shipment
PG 10 PG 10	Parameter group 10		The first characters of parameter group (PG) 10. They are also displayed first when the instrument is set to engineer level.	
Pb Pb	PV bias	-5.00 to +5.00% of span	Sensor correction is made by adding bias value to measured-value (PV).	0.00
dF 1 dF 1	PV digital filter	0 to 100 sec ("0" setting: PV digital filter OFF)	Noise in measured-value (PV) input is reduced by the employment of first-order lag filter.	0
PLC PLC	PV low input cut-off	0.00 to 25.00% of span	As a result of square root extraction, low input value with large variation is cut.	1.00

*Displayed only when "Square root extraction provided" (PG20) is selected for voltage and current inputs.

2.2 RS (remote setting input) section [Parameter group (PG) 11]

Symbol	Name	Setting range	Description	Initial value prior to shipment
PG 11 PG 11	Parameter group 11		The first characters of parameter group (PG) 11.	
rr rr	RS ratio	0.001 to 9.999 of remote set-value (RS) ("0.000" cannot be set.)	Multiplying factor is set to remote set-value (RS) to adjust input gradient.	1.000
rb rb	RS bias	-19.99 to +50.00% of span	Input correction is made by adding bias value to remote set-value (RS).	0.00
dF 2 dF 2	RS digital filter	0 to 100 sec ("0" setting: RS digital filter OFF)	Noise in remote set-value (RS) input is reduced by the employment of first-order lag filter.	0

*Not displayed when there is no remote setting input function.

2.3 Output section [Parameter group (PG) 12]

Symbol	Name	Setting range	Description	Initial value prior to shipment
PG 12	Parameter group 12		The first characters of parameter group (PG) 12.	
PG 12				
*1 oLH	Output limit (high limit)	-5.0 to 105.0% of manipulated output	High limit of manipulated output value (MV). For heating/cooling PID action: Output limit (high limit) on the heating-side output.	105.0
oLH				
*1 oLL	Output limit (low limit)		Low limit of manipulated output value (MV). For heating/cooling PID action: Output limit (high limit) on the cooling-side output.	-5.0 (For heating/cooling PID action: 105.0)
oLL				
*2 orU	Increase in output change rate limit	0.0 to 100.0%/sec of span ("0.0" setting: Output change rate limit OFF)	Sets gradient when output needs to be gradually increased.	0.0
orU				
*2 ord	Decrease in output change rate limit		Sets gradient when output needs to be gradually decreased.	0.0
ord				
*3 oHH	Upper ON/OFF action differential gap	0.00 to 10.00% of span	Sets differential gap above ON/OFF action set-value (SV).	0.02
oHH				
*3 oHL	Lower ON/OFF action differential gap		Sets differential gap below ON/OFF action set-value (SV).	0.02
oHL				
*2 PSn	Manual output at abnormality	-5.0 to +105.0% of manipulated output (For heating/cooling PID action: -105.0 to +105.0% of manipulated output)	Sets manual output value output when measured-value (PV) input exceeds input abnormality determination point.	0.0
PSM				

*1 The low limit on the heating and cooling sides for heating/cooling PID action is fixed to "-5.0%".

*1, *2 Not displayed for ON/OFF action.

*3 Displayed only for ON/OFF action.

2.4 AT (auto-tuning) section [Parameter group (PG) 13]

Symbol	Name	Setting range	Description	Initial value prior to shipment
PG 13	Parameter group 13		The first characters of parameter group (PG) 13.	
PG 13				
* ATb	Auto-tuning (AT) bias	-span to +span %	Adds bias to set-value (SV) when auto-tuning (AT) is performed.	0.0
ATb				

*Displayed only when the auto-tuning (AT) function is provided.

2.5 Alarm section 1 [Parameter group (PG) 14]

Symbol	Name	Setting range	Description	Initial value prior to shipment
PG 14 PG 14	Parameter group 14		The first characters of parameter group (PG) 14.	
*1 AH 1 AH 1	First alarm differential gap	0.00 to 10.00% of span	Sets first alarm differential gap.	0.10
*1 ALT 1 ALT 1	First alarm timer setting	0 to 600 sec	Sets time until alarm is turned ON after measured-value (PV) enters first alarm area.	0
*2 HbA HbA	Heater break alarm	0.0 to 100.0A	Set by referring to current transformer input value (CT) in the monitoring status.	0.0
*3 AH 2 AH 2	Second alarm differential gap	0.00 to 10.00% of span	Sets second alarm differential gap.	0.10
*4 ALT 2 ALT 2	Second alarm timer setting	0 to 600 sec	Sets timer until alarm is turned ON after measured-value (PV) enters second alarm area.	0 (*A)

*1 Not displayed when there is no alarm or FAIL is selected as first alarm.

*2 • Displayed only when heater break alarm is selected as second alarm.

• Set heater break alarm set-value to a value about 85% current transformer input value (CT). However, when power supply variations are large, set the alarm to a slightly smaller value.

In addition, when two or more heaters are connected in parallel, set the alarm to a slightly larger value so that it is activated even with only one heater is broken (However, within the value of CT).

• When the heater break alarm set-value is set to "0.0" or the current transformer is not connected, the heater break alarm is turned ON.

*3 Not displayed when there is no alarm, alarm output is one point, of FAIL or heater break alarm is selected as second alarm.

*4 Not displayed when there is no alarm, of alarm output is one point or FAIL is selected as second alarm.

*A When a heater break alarm is selected as second alarm: 3 sec

2.6 Analog output section [Parameter group (PG) 15]

Symbol	Name	Setting range	Description	Initial value prior to shipment
PG 15	Parameter group 15		The first characters of parameter group (PG) 15.	
PG 15				
Ao	Analog output specification selection	0: Measured-value (PV) 1: Deviation between measured-value (PV) and set-value (SV) 2: Set-value (SV) 3: Remote set-value (RS) 4: Manipulated output 1 (heating-side) 5: Manipulated output 2 (cooling-side) 6: Feedback resistance input (POS)	Selects analog output type.	0
AHS	High limit analog output range	Specification selection 0, 2, 3: Within input range 1 : -span to +span 4, 5, 6: 100.0 (Fixed)	Sets high limit of analog output range.	Temperature input: High input limit Voltage/current input: 100.0
ALS	Low limit analog output range	Specification selection 0, 2, 3: Within input range 1 : -span to +span 4, 5, 6: 0.0 (Fixed)	Sets low limit of analog output range.	Temperature input: Low input limit Voltage/current input: 0.0

*Not displayed when there is no analog output function.

2.7 Position proportioning PID action section [Parameter group (PG) 16]

Symbol	Name	Setting range	Description	Initial value prior to shipment
PG 16	Parameter group 16		The first characters of parameter group (PG) 16.	
PG 16				
db	Neutral zone	0.1 to 10.0% of output ("0.0" cannot be set.)	Sets output OFF status between open-side and closed-side outputs.	2.0
YHS	Open/close output differential gap	0.1 to 5.0% of output ("0.0" cannot be set.)	Sets differential gap of open-side and closed-side outputs.	0.2
Ybr	Action selection at feedback resistance (FBR) break	0: Open-side output OFF, closed-side output OFF 1: Open-side output OFF, closed-side output ON 2: Open-side output ON, closed-side output OFF	Selects action at feedback resistance (FBR) break.	0

*Displayed only for position proportioning PID action.

2.8 Bar-graph section [Parameter group (PG) 17]

Symbol	Name	Setting range	Description	Initial value prior to shipment
PG 17 PG 17	Parameter group 17		The first characters of parameter group (PG) 17.	
dE dE	Bar-graph display selection	0: Manipulated output value (MV) display 1 to 100 (digit/dot): Display of deviation between measured-value (PV) and set-value (SV).	Selects the details of bar-graph display	0

- *
- For manipulated output value (MV) display: 10%/bar-graph dot
 - For deviation display: Sets deviation corresponding to one dot at the specified number of digits regardless of decimal-point.
 - For position proportioning PID action: At "0" setting; feedback resistance input value (POS) display

2.9 Input section [Parameter group (PG) 20]

In this parameter group (PG), neither setting nor change can be made if the instrument is not set to the STOP status at "Operation execution (RUN)/STOP transfer" in the MODE status.

	Symbol	Name	Setting range	Description	Initial value prior to shipment
	PG20	Parameter group 20		The first characters of parameter group (PG) 20.	
#	InP	Measured-value (PV) input type selection	Sets setting code No. in "Input range table" on page 46.	If measured-value (PV) exceeds high limit of input abnormality determination point, input abnormality action is taken.	To be specified when ordering
	PoH	High limit of input abnormality determination point	Within input range	If measured-value (PV) falls below low limit of input abnormality determination point, input abnormality action is taken.	Temperature input: High input limit Voltage/current input: 100.0
	PUn	Low limit of input abnormality determination point		If measured-value (PV) falls below this limit, input abnormality action is taken.	Temperature input: Low input limit Voltage/current input: 0.0
*1	AoHE	High limit of action selection at input abnormality	0: Control output (under normal control) 1: Outputs manual output at abnormality	Selects action when measured-value (PV) exceeds high limit of input abnormality determination point.	0 (For heating/ cooling PID action: 1)
*1	AUnE	Low limit of action selection at input abnormality		Selects action when measured-value (PV) falls below low limit of input abnormality determination point.	0
*2	PGSH	High limit of input programmable range	-1999 to +9999	Sets high limit of voltage/current input scale.	1000
*2	PGSL	Low limit of input programmable range		Sets low limit of voltage/current input scale.	0
*2	PGdP	Decimal-point position selection	0: No digit below decimal-point 1: 1 digit below decimal-point 2: 2 digits below decimal-point 3: 3 digits below decimal-point	Sets decimal-point position on voltage/current input scale.	1
*2	Sqr	Square root extraction selection	0: Not provided 1: Provided	Selects the presence or absence of square root extraction function.	0

*1 Not displayed for ON/OFF action.

*2 Displayed only for voltage/current input.

. Changing this item also changes the Chapter 1, "2. Model code" (on page 6). If it is changed, please enter the new Model code in space of the Model code seals stuck inside and outside the instrument.

■ Input range table

For parameter group (PG) 20 "Measured-value (PV) input type selection", select setting code in the table.

Group		Input type	Model code	Setting code	
Temperature input	① TC	K (K)		08	0
				09	1
				10	2
				11	3
				A4	4
			A5	5	
		J (J)		07	6
				08	7
				09	8
				06	9
				A4	10
			A5	11	
		R (r)		03	12
				A1	13
S (s)		03	14		
		A1	15		
B (b) #		03	16		
		A3	17		
E (E)		03	18		
		02	19		
		A3	20		
T (T)		05	21		
		06	22		
		A6	23		
		A7	24		
N (n)		02	25		
		A1	26		
PL II (P)		01	27		
		A3	28		
W5Re/W26Re (W)		03	29		
		A2	30		
U (U)		04	31		
		A4	32		
L (L)		03	33		
		04	34		
		A2	35		
② RTD	JPt 100 (JP)		04	50	
			11	51	
			B1	52	
			B2	53	
Pt 100 (PF)		04	54		
		12	55		
		B1	56		
		B3	57		
Voltage input	③ Voltage input (Low)	mV, V (H)		60	
				61	
				62	
④ Voltage input (High)	V (H)		63		
			64		
			65		
⑤ Current input	mA (I)		66		
			67		

* Setting can be changed in each of 3 input groups ① and ②, ③ and ④, and ③ and ⑤.

. Accuracy in the range of 0 to 400°C (0 to 800°F): Not guaranteed.

2.10 Setting section [Parameter group (PG) 21]

In this parameter group (PG), neither setting nor change can be made if the instrument is not set to the STOP status at "Operation execution (RUN)/STOP transfer" in the MODE status.

Symbol	Name	Setting range	Description	Initial value prior to shipment
PG21	Parameter group 21		The first characters of parameter group (PG) 21.	
PG 21				
SLH	Setting limit (high limit)	Within input range	Sets high limit of setting range.	Temperature input: High input limit Voltage/ current input: 100.0
SLH				
SLL	Setting limit (low limit)		Sets low limit of setting range.	Temperature input: Low input limit Voltage/ current input: 0.0
SLL				
# * rInP	Remote setting (RS) input type selection	See *A	Selects remote setting (RS) input type.	To be specified when ordering
rInP				
# * TrK	SV tracking selection	0: Not provided 1: Provided	Selects the presence or absence of SV tracking in which local set-value (SV) follows remote set-value (RS).	0
TrK				

* Not displayed when there is no remote setting input function.

*A Setting range

Setting range			
	Type	Set-value	Details
①	DC voltage input (Low)	0	0 to 10mV
		1	0 to 100mV
		2	0 to 1 V
②	DC voltage input (High)	3	0 to 5 V
		4	1 to 5 V
		5	0 to 10 V
③	DC current input	6	0 to 20mA
		7	4 to 20mA

Hardware is different for ①, ② and ③. Therefore only setting meeting the specification can be used.

For example, for current input, only "6" or "7" can be set.

. Changing this item also changes the Chapter 1. "2. Model code" (on page 6). If it is changed, please enter the new Model code in space of the Model code seals stuck inside and outside the instrument.

2.11 Control section [Parameter group (PG) 22]

In this parameter group (PG), neither setting nor change can be made if the instrument is not set to the STOP status at "Operation execution (RUN)/STOP transfer" in the MODE status.

Symbol	Name	Setting range	Description	Initial value prior to shipment
PG22 PG 22	Parameter group 22		The first characters of parameter group (PG) 22.	
*1 CY1 CY 1	Proportioning cycle	1 to 100 sec ("0" cannot be set)	Sets control output cycle. For heating/cooling PID: Heating-side proportioning cycle	20 (*A)
*2 CY2 CY 2	Cooling-side proportioning cycle		Sets cooling-side output cycle for heating/cooling PID action.	20 (For voltage pulse output: 2)
*3 oS1 oS 1	Direct/reverse action selection	0: Direct action 1: Reverse action	Selects direct or reverse control action.	1
*4 Pd Pd	Hot/cold start selection	0: Hot start 1 1: Hot start 2 2: Cold start	Selects action after power recovery.	0 (For heating/cooling PID action: 1)
*4 PdA PdA	Start determination point	0.1 to 100.0% of span ("0.0" cannot be set)	Setting of deviation form set-value (SV).	3.0

*1 Not displayed for ON/OFF action, position proportioning PID action and current/continuous voltage output.

*2 Displayed only for heating/cooling PID action, but not displayed for current/continuous voltage output.

*3 Not displayed for heating/cooling PID action.

*4 Not displayed for ON/OFF action.

For details, see Chapter 2, "3.3 Action during power failure" on page 36.

*A For voltage pulse output or trigger for triac driving output: 2 sec

2.12 Alarm section 2 [Parameter group (PG) 23]

In this parameter group (PG), neither setting nor change can be made if the instrument is not set to the STOP status at "Operation execution (RUN)/STOP transfer" in the MODE status.

	Symbol	Name	Setting range	Description	Initial value prior to shipment
	PG23	Parameter group 23		The first character of parameter group (PG) 23.	
#	AS1	First alarm action selection	See *A	Selects first alarm action.	To be specified when ordering.
*2	EXC1	First alarm energized/de-energized selection	0: Energized alarm 1: De-energized alarm	Selects whether first alarm is set to energized alarm or de-energized alarm.	0
*2	AEo1	First alarm action selection at input abnormality	See *B	Selects first alarm action when measured-value (PV) exceeds input abnormality determination point.	0
#	AHo1	First alarm hold action selection	See *C	Selects the first alarm hold action	To be specified when ordering.
#	AS2	Second alarm action selection	See *A	Selects second alarm action.	To be specified when ordering.
*4	EXC2	Second alarm energized/de-energized selection	0: Energized alarm 1: De-energized alarm	Selects whether second alarm is set to energized alarm or de-energized alarm.	0
*4	AEo2	Second alarm action selection at input abnormality	See *B	Selects second alarm action when measured-value (PV) exceeds input abnormality determination point.	0
#	AHo2	Second alarm hold action selection	See *C	Selects the second alarm hold action.	To be specified when ordering.

*1, *2 . . . Not displayed when there is no alarm

*2 Not displayed if "6" (FAIL) is selected in "First alarm action selection".

*3, *4 . . . Not displayed when there is no alarm or alarm output is 1 point.

*4 Not displayed when "6" (FAIL) or "7" (heater break alarm) is selected in "Second alarm action selection".

*A 0: Process alarm (High limit)

1: Process alarm (Low limit)

2: Deviation alarm (High limit)

3: Deviation alarm (Low limit)

4: Deviation high/low alarm

5: Band alarm

6: FAIL

7: Heater break alarm (Displayed only for second alarm action selection)

Not displayed when there is no heater break alarm function.

*B 0: No alarm action

1: Alarm ON when measured-value (PV) is out of high or low limit of input abnormality determination point.

2: Alarm ON when measured-value (PV) exceeds high limit of input abnormality determination point.

3: Alarm ON when measured-value (PV) falls below low limit of input abnormality determination point.

*C 0: No hold action

1: Hold action1: Hold action is valid when the instrument is power-ON or transferred operation mode from STOP to execution (RUN).

2: Hold action2: Hold action is valid when the instrument is power-ON, transferred operation mode from STOP to execution (RUN) or changed the set-value (SV).

. . . . Changing this item also changes the Chapter 1, "2. Model code" (on page 6). If it is changed, please enter the new Model code in space of the Model code seals stuck inside and outside the instrument.

2.13 Communication section [Parameter group (PG) 24]

In this parameter group (PG), neither setting nor change can be made if the instrument is not set to the STOP status at "Operation execution (RUN)/STOP transfer" in the MODE status.

Symbol	Name	Setting range	Description	Initial value prior to shipment
PG24 PG 24	Parameter group 24		The first characters of parameter group (PG) 24.	
*1 bIT	Communication data bit configuration	See *A	Selects data bit configuration during communication.	11
*1 Add	Device address	0 to 99	Sets device address of this instrument.	0
*1 bPS	Communication speed	0: 1200bps 1: 2400bps 2: 4800bps 3: 9600bps 4: 19200bps	Selects communication speed.	3
*1 InT	Interval time	0 to 250msec	Sets interval time to match timing during data send and receive.	0
*2 KEY	Key entry valid/invalid during communication	0: Invalid 1: Valid	Selects whether key entry is valid or not during communication.	0

*1, *2 . . . Not displayed when there is no communication function.

*2 The setting of "1" is valid only for setting changes at operator levels 1 and 2. Also each setting by key operation can be confirmed regardless of validity or invalidity.

*A

Setting	Parity bit	Data bit [bit]	Stop bit [bit]
0	None	8	1
1	None	8	2
2	Even	8	1
3	Even	8	2
4	Odd	8	1
5	Odd	8	2
6	None	7	1
7	None	7	2
8	Even	7	1
9	Even	7	2
10	Odd	7	1
11	Odd	7	2

2.14 Data lock section [Parameter group (PG) 40]

Symbol	Name	Setting range	Description	Initial value prior to shipment
PG40	Parameter group 40		The first characters of parameter group (PG) 40.	
PG 40				
LCE	Set data lock level	0: All settings locked 1: Only set-value (SV) can be changed. 2: Engineer level lock	Set level which enables set data lock.	0
LCK				
ArE	Area lock	0: Enable of memory area change when set data locked. 1: Disable of memory area change when set data locked.	Selects enable/disable of memory area change when set data is locked.	1
ArE				
* SToP	Operation RUN/STOP display lock	0: Not displayed "Operation execution (RUN)/STOP transfer" 1: Displayed "Operation execution (RUN)/STOP transfer"	Selects the presence or absence of "Operation execution (RUN)/STOP transfer" display in MODE status.	1
SToP				

* If "0" (not displayed) is selected after the operation is stopped by the "Operation execution (RUN)/STOP transfer" in the MODE status, the operation may not be executed (RUN).

Chapter 4 MAINTENANCE

1. MAINTENANCE AND INSPECTION

Always perform the following maintenance and inspection, to use this instrument under the best conditions.

Sensor	<ul style="list-style-type: none"> ● Confirm that the sensor is installed correctly. ● Replace the sensor before deterioration of its characteristics. ● Confirm that there is no wire break nor shorting.
Instrument	<ul style="list-style-type: none"> ● Confirm that the data satisfying the requirements is set. ● Confirm that the instrument operates normally. ● Confirm that the installation direction is correct. ● Confirm that communication is conducted normally during communication.
Output and load circuit	<ul style="list-style-type: none"> ● For the relay contact output type, inspect control output relay burning, wear and tear and imperfect contact. If the control output relay is deteriorated, replace the relay. * Relay used: Manufactured by Matsushita Denko DSP1-DC12V [Model No.: AGP2013 (For general purpose) AGP20139 (For UL/CSA specifications)] ● For the continuous voltage output and voltage pulse output types, confirm output voltage. In addition, confirm the operation of actuators connected externally. ● For the current output type, confirm output current. In addition, confirm the operation of actuators connected externally. ● Confirm no load is disconnected. ● Confirm the wiring is correct. ● Confirm no imperfect contact exists.

2. TROUBLESHOOTING

Instrument trouble, causes and remedies considered to be general are described in the following tables.

For any trouble occurring due to causes other than the following, contact your agent where you purchased the instrument or directly us after confirming the Model No. and specifications.

Trouble		Cause	Remedy
Display	No display appears	The internal assembly is not inserted into the case correctly	Insert the internal assembly into the case correctly.
		Power supply terminal connection not correct	Connect the terminals correctly by referring to Chapter 1 "4.1 Terminal configuration" (Page 10).
		Normal power supply voltage not supplied	Apply the normal power supply voltage by referring to Chapter 5 "8. General specification" (Page 61).
	Display is abnormal	Noise source present near the instrument	Separate the noise source from the instrument.
		Remote setting signal is input in parallel to two or more REX-F900s which use grounding type thermocouples	Insert an isolator to enable isolated remote setting signal input for each instrument.
Measured-value (PV) display differs from the actual value	A PV bias is set	Set the PV bias to "0" by referring to Chapter 3 "2.1 PV section" (Page 40). However, this is limited only to when the PV bias setting can be changed.	
Remote set-value display differs from the actual value	An RS bias is set	Set the RS bias to "0" by referring to Chapter 3 "2.2 RS section" (Page 40). However, this is limited only to when the RS bias setting can be changed.	
Control	Control is abnormal	Normal power supply voltage is not supplied	Apply the normal power supply voltage by referring to Chapter 5 "8. General specification" (Page 61).
		Break of sensor and input lead wires	Turn off the power or stop the operation by "Operation execution/stop transfer" referring to Chapter 2, "2.5 Mode status" (Page 28) and repair the sensor or replace it.
		Proper sensor is not used	Check the sensor and use it satisfying the specification.
		Sensor wiring improperly conducted	Conduct sensor wiring correctly by referring to Chapter 1 "4.1 Terminal configuration" (Page 10).
		Sensor insertion depth is insufficient	Check whether sensor is inserted loosely. If yes, fully insert the sensor.
		Sensor insertion position is not appropriate	Insert the sensor at the specified location.
		Input signal wires are not separated from instrument power and/or load wires	Separate the former from the latter.
		Noise source is present near the wiring	Separate the noise source from the wiring
		Inappropriate PID constants	Set the correct PID constants.
	The minus or plus sides of heating and cooling-side outputs are connected to actuators in common for heating/cooling PID action	Separate each output.	
Auto-tuning (AT) function not activated	Requirements for performing the auto-tuning (AT) function are not satisfied	Satisfy the requirements for performing the auto-tuning (AT) function by referring to Chapter 2, "3.2 Requirements for auto-tuning (AT)" (Page 35).	
Auto-tuning suspended	Requirements for suspending the auto-tuning (AT) function are established	Identify causes for auto-tuning (AT) suspension by referring to Chapter 2, "3.2 Requirements for auto-tuning (AT)" (Page 35) and then remove them. Thus, execute the auto-tuning (AT) function again.	

	Trouble	Cause	Remedy
Control	No optimum PID constants obtained even after auto-tuning (AT) function execution	The auto-tuning (AT) function does not match the characteristic of controlled object	Set PID constants manually.
		The output change rate limit is set	Set PID constants manually. Set the output change rate limit to "0.0" by referring to Chapter 3, "2.3 Output section" (Page 41). However, this is limited only to the case where output change rate limit setting may be changed.
	No output change in step	The output change rate limit is set	Set the output change rate limit to "0.0" by referring to Chapter 3, "2.3 Output section" (Page 41). However, this is limited only to the case where output change rate limit setting may be changed.
Operation	Output does not become more than (or less than) a specific value	The output limit is set	Change the output limit setting by referring to Chapter 3, "2.3 Output section" (Page 41). However, this is limited only to the case where output limit setting may be changed.
	No operation performed *Excluding the case where communication is conducted	"0" (Not displayed) is set at "Operation RUN/STOP display lock" of ENGINEER LEVEL (PG40)	Set "Operation RUN/STOP display lock" to "1" by referring to Chapter 3, "2.14 Data lock section" (Page 51).
	No setting change can be made by key operation	Set data is locked	Set the "Set data unlock/lock transfer" to the "unlock" by referring to Chapter 2, "2.5 Mode status" (Page 28).
		Set to the computer mode	Set the controller to the "local mode" by "Local/computer transfer" referring to Chapter 2, "2.5 Mode status" (Page 28).
	No control area transfer can be made by key operation	Set to the external mode	Set the "Control area internal (local)/external transfer" to the "local mode" by referring to Chapter 2, "2.5 Mode status" (Page 28).
		Set to the computer mode	Set the controller to the "local mode" by the "Local/computer transfer" referring to Chapter 2, "2.5 Mode status" (Page 28).
	No control area transfer can be made by contact input	Set to the local mode	Set the "Control area internal (local)/external transfer" to the "external mode" by referring to Chapter 2, "2.5 Mode status" (Page 28).
Set-value (SV) does not become more than (or less than) a specific value	The setting limit is set	Change the setting limit setting by referring to Chapter 3, "2.10 Setting section" (Page 47). This is limited only to the case where the setting limit may be changed.	
Set-value (SV) does not change immediately when the set-value (SV) is changed	The setting change rate limit is set	Set the "setting change rate limit" to "0.0" by referring to Chapter 2, "2.3 Set status" (Page 22). However, this is limited only to the case where the setting change rate limit may be changed.	
Others	Alarm action is abnormal	Alarm action is different from the specification	Change the action by referring to Chapter 3, "2.12 Alarm section 2" (Page 49) after the specification is confirmed.
		Alarm output relay contact energized/de-energized is reversed	Set contact energized/de-energized by referring to Chapter 3, "2.12 Alarm section 2" (Page 49).
		Alarm differential gap setting is inappropriate	Set the appropriate differential gap by referring to Chapter 3, "2.5 Alarm section 1" (Page 42).
		The alarm timer is set	Change the timer setting by referring to Chapter 3, "2.5 Alarm section 1" (Page 42). This is limited only to the case where the alarm timer setting may be changed.

3. DISPLAY AT ABNORMALITY

■ For input abnormality

Display	Details	Action (output)	Measures
Measured-value (PV) Flashing	Input abnormality (Measured-value (PV) exceeds the high input abnormality determination limit or less than the low input abnormality determination limit.)	<ul style="list-style-type: none"> Action at input abnormality (Outputs manual output value at abnormality.) *However, only when the action at input abnormality selected. Alarm output (Outputs by operation selection at alarm input abnormality.) 	Check input type, range, sensor and sensor connection. When replace the sensor, turn off the power or stop the operation by "Operation execution/stop transfer" in the MODE status.
□□□□ Flashing	Overscale (Measured-value (PV) is beyond the effective input range.)		
▭▭▭▭ Flashing	Underscale (Measured-value (PV) is below the effective input range.)		

Each status at input abnormality is shown in the following:

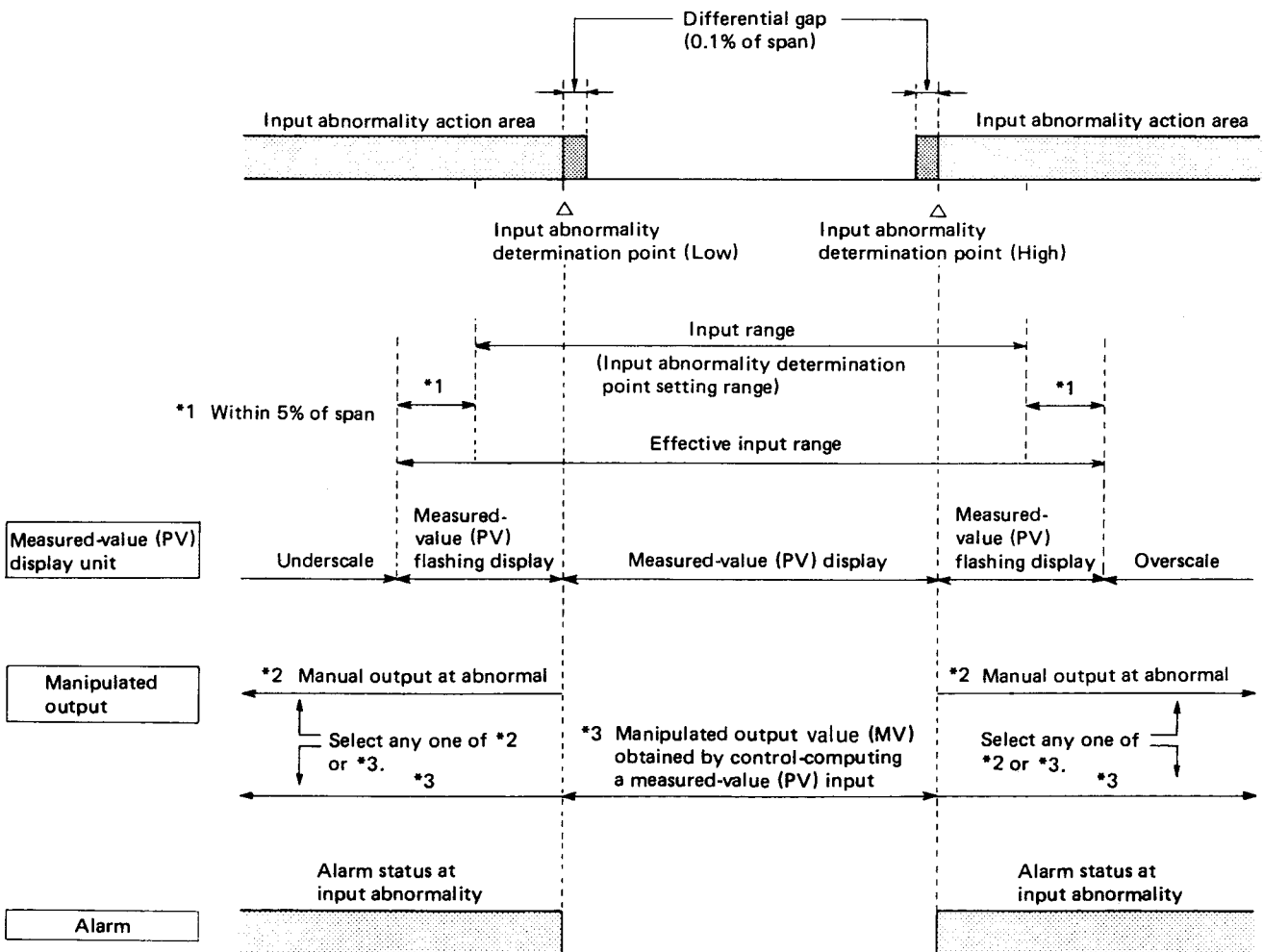

Cautions

1. Set input abnormality determination point (high/low limit) setting, action (high/low limit) selection at input abnormality and manual output setting at abnormality using the engineer level (see Chapter 3. "ENGINEER LEVEL" on page 37) in the SET status.
2. Even when there is no manual mode, manual output at abnormality is valid.
3. For ON/OFF action, there is no manual output at abnormality.

■ **Self-diagnostic function**

Display	Details	Action (output)	Measures
<p>Err 1</p> <p>Lights</p>	<p>Auto-tuning error (Auto-tuning did not end) (normally)</p>	<p>As usual</p>	<p>Pressing any key erases error display to display each status.</p>
<p>Err 2</p> <p>Flashing (Others extinguish)</p>	<p>Input value error</p>	<p>All outputs: OFF (When FAIL is selected for the first or second alarm: FAIL output; Contact open)</p>	<p>Turn the power-OFF once. If the instrument resets to error status after power-ON, contact your nearest RKC's agent or our sales office.</p>
<p>Err 3</p> <p>Flashing (Others extinguish)</p>	<p>RAM error</p>		
<p>FAIL lamp lights (Others extinguish)</p>	<ul style="list-style-type: none"> ● ROM error ● CPU power supply error ● Watch-dog timer error 		

Chapter 5

SPECIFICATION

1. Input

- (1) Input type
- : (a) Thermocouple input group
 - ① Thermocouple input type : K, J, R, S, B, E, T, N, PLII, W5Re/W26Re, U, L
 - ② Signal source resistance effect : Approx. $0.20\mu\text{V}/\Omega$
 - ③ Input impedance : $1\text{M}\Omega$ or more
 - ④ Action at input break : Specify any of upscale or downscale
 - (b) RTD input group
 - ① RTD input type : Pt100, JPt100
 - ② Sensor current : Approx. 0.25mA
 - ③ Allowable input lead : 20Ω or less
 - ④ Action at input break : Upscale
 - ⑤ Action at input shorting : Downscale
 - (c) DC voltage (low) input group
 - ① DC voltage (low) input type : 0 to 10mV DC , 0 to 100mV DC , 0 to 1V DC
 - ② Input impedance : Approx. $1\text{M}\Omega$
 - ③ Allowable input voltage : Within $\pm 4\text{V}$
 - ④ Action at input break : Downscale (Indicates value near 0.)
 - (d) DC voltage (high) input group
 - ① DC voltage (high) input type : 0 to 5V DC , 1 to 5V DC , 0 to 10V DC
 - ② Input impedance : Approx. $1\text{M}\Omega$
 - ③ Allowable input voltage : Within $\pm 12\text{V}$
 - ④ Action at input break : Downscale (Indicates value near 0.)
 - (e) DC current input group
 - ① DC current input type : 0 to 20mA DC , 4 to 20mA DC
 - ② Input impedance : Approx. 50Ω
 - ③ Action at input break : Downscale (Indicates value near 0.)
- (2) Accuracy
- : (a) Measuring accuracy : $\pm(0.1\%$ of span + 1 digit)
(However, thermocouple type B input 0 to 400°C (0 to 800°F): not guaranteed)
 - (b) Cold junction temperature compensation error : Within $\pm 1.0^\circ\text{C}$ (From 0 to 50°C)
However, When measured-value (PV) is between -100°C and -150°C : Within $\pm 2.0^\circ\text{C}$
When measured-value (PV) is between -150°C and -200°C : Within $\pm 3.0^\circ\text{C}$
- (3) Sampling cycle : 0.25sec
- (4) PV bias : -5.00 to $+5.00\%$ of span
- (5) PV digital filter : The first order lag filter : 0 to 100sec ("0" setting: PV digital filter OFF)
- (6) Square root extraction : The presence or absence of this function can be selected.
- (a) PV low input cut off : 0.00 to 25.00% of span
 - (b) Square root extraction accuracy : $\pm 0.2\%$ of span when the square root extraction result is more than 1%.
- * The square root extraction function can be selected only when measured-value (PV) input is voltage or current input.

2. Display function

- (1) Measured-value (PV) display unit : 4-digit, 7-segment LED (Green)
- (2) Set-value (SV) display unit : 4-digit, 7-segment LED (Orange)
- (3) Memory area display unit : 1-digit, 7-segment LED (Orange)
- (4) Bar-graph display unit : 20 dot LED (Green)

3. Setting

- (1) Setting range : Set-value (SV) : Same as input range
- (2) Setting resolution : (a) Thermocouple input : 1°C[°F] or 0.1°C[°F]
(b) RTD input : 1°C[°F] or 0.1°C[°F]
(c) Voltage•Current input : Depending on input range
- (3) Setting limit : Any input range value
- (4) Setting change rate limit : 0.0 to 100.0%/minute of span ("0.0" setting: Setting change rate limit OFF)
- (5) Memory area function : (a) No. of memory areas : 8
(b) Memory area selection
 - ① Selection by front key
 - ② Selection by contact input (See Additional function "D. Contact input" on page 65.)
 - ③ Selection by communication
- (6) Remote setting : See Additional function "B. Remote setting" (Page 63).

4. Control

- (1) Control action type : (a) ON/OFF control : Differential gap (upper)
: 0.00 to 10.00% of span
: Differential gap (lower)
: 0.00 to 10.00% of span
(b) Brilliant PID control : Proportional band (P)
: 0.1 to 999.9% of span ("0.0" can not be set.)
Integral time (I)
: 1 to 3600 sec ("0" can not be set.)
Derivative time (D)
: 0 to 3600 sec
("0" setting: Derivative action OFF)
Control response designation parameter
: Slow, Medium, Fast (3-Step selection)
Proportioning cycle
: 1 to 100 sec ("0" can not be set.)
Output limit (high-limit)
: -5.0 to +105.0%
Output limit (low-limit)
: -5.0 to +105.0%
Output change rate limit
: 0.0 to 100.0%/sec
("0.0" setting: output change rate limit OFF)
* For enhanced auto-tuning function, see Additional function "F. Auto-tuning function" (Page 68).
(c) Position proportioning control
: See Additional function "G. Position proportioning control" (Page 69).
(d) Heating/cooling control
: See Additional function "H. Heating/cooling control" (Page 70).

- (2) Control cycle : 0.25 sec
- (3) Operation (control) execution/stop function : Provided as standard
- (4) Direct/Reverse action : Changeable by setting
- (5) Balanceless/bumpless function : Bi-directionally Balanceless/bumpless during auto/manual transfer

5. Control output

- (1) Continuous current output : 0 to 20mA DC, 4 to 20mA DC
 - (a) Allowable load resistance : 600Ω or less
 - (b) Output impedance : 5MΩ or more
- (2) Continuous voltage output : 0 to 5V DC, 0 to 10V DC, 1 to 5V DC
 - (a) Allowable load resistance : 1kΩ or more
 - (b) Output impedance : 0.1Ω or less
- (3) Voltage pulse output : 0/12V DC
 - (a) Allowable load resistance : 600Ω or more
 - (b) Cycle : 1 to 100sec variable
- (4) Relay contact output : 250V AC, 3A (Resistive load) 1c contact
 - (a) Electrical life : 300,000 time or more (Rated load)
 - (b) Cycle : 1 to 100sec variable
- (5) Trigger output for triac driving : (a) Trigger type : Zero-cross method
 (b) Execution ON current : 50mA (At=50°C), 70mA (At=25°C)

6. Action at input abnormality

- (1) Setting : (a) Input abnormality determination point (High, Low limit) : Same as input range
 (b) Differential gap : 0.1% of span (Fixed)
 (c) Outputs manual output value at abnormality : -5.0 to +105.0%
 (For heating/cooling PID action: -105.0 to +105.0%)
 (d) Action selection at input abnormality : Selects whether manual output value at abnormal is output or value as a result of control computation is output.
- (2) Display : Measured-value (PV) flashes if the measured-value (PV) is above or below the high/low limits of input abnormality determination point.

7. Self-diagnostic function

- (1) Check item : (a) ROM•RAM check
 (b) Input value check
 (c) CPU power monitoring
 (d) Watch-dog timer
- (2) Display in trouble : Only the FAIL lamp lights up
 (Error message display at back up and input value checking)
- (3) Output in trouble : All outputs : OFF
 FAIL output : Open
 FAIL output : Relay contact
 250V AC, 1A (Resistive load)
 1a contact

* Alarm output can be selected to FAIL output.

8. General specification

- (1) Insulation resistance : Between measuring and grounding terminals
: 20MΩ or more at 500V DC
Between power and grounding terminals
: 20MΩ or more at 500V DC
- (2) Dielectric resistance : Between measuring and grounding terminals
: 1 minute at 1000V AC
Between power and grounding terminals
: 1 minute at 1500V AC
- (3) Power supply voltage : 90 to 264V AC [Including power supply variation] (Rated: 100 to 240V AC)
24V AC, 24V DC
- (4) Power consumption : 90 to 264 V AC : 15VA or less
24V AC : 8VA or less
24V DC : 350mA or less
- (5) Power failure effect : No influence even under power failure of less than 50msec
Instantaneous power failure : Hot start 1, 2 and Cold start
(According to the mode specified by setting)
- (6) Warm up time : 60 minutes
- (7) Memory back up : RAM back up by lithium cells
About 10 years
(However, varies with product storage period, storage environment and operating environment.)
- (8) Weight : Approx. 450g or less
- (9) Accessories : Mounting brackets, 2pcs. (1 set)
Engineering unit seal

9. Working environment conditions (Normal operating conditions)

- (1) Ambient temperature : 5 to 40°C (41 to 104°F)
- (2) Ambient humidity : 20 to 80% (RH)
- (3) Operating environment : There should be neither corrosive gases nor much dust
- (4) Power supply voltage : ±10% of rating
- (5) Power supply frequency : ±5% of rating
- (6) Magnetic field : 400AT/m or less
- (7) Warm-up time : 60 minutes or more

10. Transportation and storage conditions

- (1) Temperature : -20 to +50°C (-4 to +122°F)
- (2) Humidity : 95% (RH) or less (non-condensing)
- (3) Vibration : 5m/sec²
- (4) Mechanical shock : 100m/sec²

*Prior to operating the instrument stored for more than 6 months, its re-calibration and operation check are required

[ADDITIONAL FUNCTION]

A. Alarm function

- (1) No. of alarm point : 2 points
- (2) Alarm types : High-limit process alarm, Low-limit process alarm, High-limit deviation alarm, Low-limit deviation alarm, Deviation High/Low alarm, Band alarm, FAIL alarm (Changeable by setting)
- (3) Setting range : (a) Process alarm : Same as input range
(b) Deviation alarm : (–span or –1999) to (+span or +9999)
(c) Band alarm : 0 to (+span or +9999)
(d) Deviation High/Low alarm : 0 to (+span or +9999)
- (4) Differential gap : 0.00 to 10.00% of span
- (5) Alarm timer : 0 to 600sec
- (6) Hold action functions : (a) No hold action*
(b) Hold action 1*: Hold action is valid when the instrument is power-ON or transferred from STOP to execution (RUN).
(c) Hold action 2*: Hold action is valid when the instrument is power-ON, transferred from STOP to execution (RUN) or changed the set-value (SV).
*Changeable by setting
- (7) Energized/de-energized alarm : The presence or absence of this function can be selected.
- (8) Output : (a) Relay contact output 1a contact
(b) 250V AC, 1A (Resistive load)
(c) Electrical life : 50,000 time or more (Rated load)
(d) Energized/de-energized alarm (Changeable by setting)
- (9) Alarm action at input abnormality : (a) No alarm action *
(b) Alarm ON when measured-value (PV) is out of high or low limit of input abnormality determination point. *
(c) Alarm ON when measured-value (PV) exceeds high limit of input abnormality determination point. *
(d) Alarm ON when measured-value (PV) falls below low limit of input abnormality determination point. *
*Changeable by setting

B. Remote setting (RS) function

- (1) Setting signal : (a) DC (Low) voltage : 0 to 10mV DC, 0 to 100mV DC, 0 to 1V DC
Input impedance : Approx. $1M\Omega$
(b) DC (High) voltage : 0 to 10V DC, 0 to 5V DC, 1 to 5V DC
Input impedance : Approx. $1M\Omega$
(c) DC current : 0 to 20mA DC, 4 to 20mA DC
Input impedance : Approx. 50Ω
- (2) RS sampling cycle : 0.5 sec
- (3) RS bias : -19.99% to 50.00% of span
- (4) RS ratio : 0.001 to 9.999
- (5) RS digital filter : The first order lag filter : 0 to 100 sec ("0" setting: RS digital filter OFF)
- (6) Allowable input voltage : (a) DC (low) voltage : Within $\pm 4V$
(b) DC (high) voltage : Within $\pm 12V$
- (7) Action at remote setting (RS) input break : Downscale (Indicates value near 0.)

C. Analog output function

- (1) No. of output point : 1 point
- (2) Output types : Measured-value (PV), Deviation value, Set-value (SV), Remote set-value (RS), Manipulated output 1 (Heating-side), Manipulated output 2 (Cooling-side), Feedback resistance input value (POS)
- * Changeable by setting.
- * Feedback resistance input is valid only for position proportioning control.
- * Manipulated output 2 (cooling-side) is valid only for heating/cooling control.
- (3) Setting signal : DC voltage input : 0 to 10mV DC, 0 to 100mV DC, 0 to 1V DC, 0 to 5V DC, 1 to 5V DC, 0 to 10V DC
- DC current input : 0 to 20mA DC, 4 to 20mA DC

[Output impedance/allowable load resistance]

Output signal	Output impedance	Allowable load resistance
0 to 10mV DC	Approx. 10Ω	20kΩ or more
0 to 100mV DC		
0 to 1 V DC	0.1Ω or less	1kΩ or more
0 to 5 V DC		
0 to 10 V DC		
1 to 5 V DC		
0 to 20mA DC	5MΩ or more	600Ω or less
4 to 20mA DC		

- (4) Analog output range :
- (a) Measured-value (PV) : Same as input range
 - (b) Deviation of measured-value (PV) from set-value (SV) : (-span or -1999) to (+span or +9999)
 - (c) Set-value (SV) : Same as input range
 - (d) Remote set-value (RS) : Same as input range
 - (e) Manipulated output 1 (Heating-side) : 0.0 to 100.0 (Fixed)
 - (f) Manipulated output 2 (Cooling-side) : 0.0 to 100.0 (Fixed)
 - (g) Feedback resistance input value (POS) : 0.0 to 100.0 (Fixed)
- (5) Output resolution : 11 bit or more
- (6) Output accuracy : 0.1% of span

D. Contact input function

- (1) No. of input point : (a) Memory area selection : 3 point
(b) Operation mode selection : 1 point
- ① AUTO/MAN transfer, MAN when opened *
 - ② REM/LOC transfer, LOC when opened *
 - ③ COMP/LOC transfer, LOC when opened *
- *Specify any of the above.
- (2) Input type : Dry contact input
- (a) $500\text{k}\Omega$ or more : Open
 - (b) 10Ω or less : Close

E. Communication function

- (1) Interface : ① EIA standard Based on RS-422A
 ② EIA standard Based on RS-485
 ③ EIA standard Based on RS-232C
- (2) Connection method : ① 4-wire system, half-duplex multi-drop connection *1
 ② 2-wire system, half-duplex multi-drop connection *2
 ③ 3-wire system, half-duplex point to point connection *3
 *1 Specification conforming to RS-422A
 *2 Specification conforming to RS-485
 *3 Specification conforming to RS-232C
- (3) Communication distance : ① RS-422A, RS-485 : 1km (Max)
 ② RS-232C : 15m (Max)
 *However, communication distance varies slightly with the surroundings such as cables, etc.
- (4) Synchronous method : Start/stop synchronous type
- (5) Communication speed : 1200bps, 2400bps, 4800bps, 9600bps, 19200bps
- (6) Data type : ① Start bit : 1
 ② Data bit : 7 or 8
 ③ Parity bit : None or 1 (Odd number or even number)
 ④ Stop bit : 1 or 2
- (7) Transmission control procedure : ANSI X3.28 subcategory 2.5, A4
 Polling/selecting type
- (8) Error control : ① Vertical parity (With parity bit selected)
 ② Horizontal parity
- (9) Block length : Within 16 bytes
- (10) Maximum connection : ① RS-422A : 32 sets including a host computer
 (However, 32 sets may not always be connected depending on host-computer driver performance.)
 ② RS-485 : 32 sets including a host computer
 ③ RS-232C : 1 point
- (11) Communication code : JIS/ASCII 7-bit code
- (12) Details of terminals : ① RS-422A (4-wire system)

Terminal No.	Signal name	Sig. direction REX-F900 ↔ HOST	Remarks
26	SG	↔	Signal ground
27	T(A)	→	Send data
28	T(B)	→	Send data
29	R(A)	←	Receive data
30	R(B)	←	Receive data

② RS-485 (2-wire system)

Terminal No.	Signal name	Sig. direction REX-F900 ↔ HOST	Remarks
26	SG	↔	Signal ground
27	T/R(A)	↔	Send data/Receive data
28	T/R(B)	↔	Send data/Receive data

③ RS-232C

Terminal No.	Signal name	Sig. direction REX-F900 ↔ HOST	Remarks
26	SG	↔	Signal ground
27	SD	→	Send data
28	RD	←	Receive data

(13) Signal logic

: ① RS-422A, RS-485

Signal voltage	Logic
$V(A) > V(B)$	0 (Space status)
$V(A) < V(B)$	1 (Mark status)

② RS-232C

Signal voltage	Logic
+3V or more	0 (Space status)
-3V or less	1 (Mark status)

(14) Bit configuration

Example; For data bit: 7, parity bit: 1 and stop bit: 2

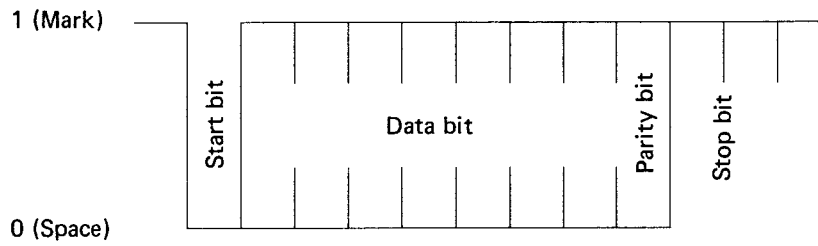

F. Auto-tuning function

- (1) Display : Transmission type surface light emitting diode (LED) display (Green)
- (2) AT cycle : 2 cycle (Fixed)
- (3) Requirement for auto-tuning (AT) start
- : (a) In the MODE status
 - AUTO/MAN transfer → Auto mode
 - LOC/REM transfer → Local mode
 - PID/Auto-tuning → PID control
 - Operation execution (RUN)/Stop (STOP) transfer → execution (RUN)
 - (b) Input value should not be abnormal.
(According to the input abnormality determination point)
 - (c) The high output limit value should be 0.1% or more and the low output limit value, 99.9% or less
- (4) Requirements for auto-tuning (AT) suspension
- : (a) When set-value (SV) is changed
 - (b) When the control area is changed
 - (c) When high or low output limit value is changed
 - (d) When PV bias and/or PV digital filter are changed
 - (e) When AT bias is changed
 - (f) When the instrument is transferred to the manual mode by "AUTO/MAN transfer"
 - (g) When the instrument is transferred to the remote mode by "LOC/REM transfer"
 - (h) When the instrument is transferred to PID control by "PID/AT transfer"
 - (i) When operation is stopped by "operation execution (RUN)/STOP transfer"
 - (j) When input value becomes abnormal.
(According to the input abnormality determination point)
 - (k) When power failure occurs
 - (l) When the instrument is in the FAIL status
- (5) AT bias : (–span or –1999) to (+span or +9999)

G. Position proportioning control

- (1) Setting : (a) Neutral zone : 0.1 to 10.0% of output
(b) Differential gap : 0.1 to 5.0% of output
(c) Action at feedback resistance (FBR) input break
: ① Open-side output OFF, *
closed-side output OFF
: ② Open-side output OFF, *
closed-side output ON
: ③ Open-side output ON, *
closed-side output OFF
* Changeable by setting
- (2) Feedback resistance input : 135Ω (standard)(Can be specified from 100Ω to 10kΩ)
- (3) Output : (a) Relay contact output
(b) 250V AC, 3A (Resistive load)
(c) Electrical life : 300,000 time or more (Rated load)
(d) Open side : 1c contact
(e) Close side : 1a contact
- (4) Motor revolution : Conforming to 20 to 240 sec
- (5) Minimum output ON time : 25msec

H. Heating/cooling control

- (1) Setting
- : (a) Cooling-side proportional band : 0.1 to 999.9% of span ("0.0" can not be set)
 - (b) Deadband : 0.0 to 10.0% of span
 - (c) Overlap : -10.0 to 0.0% of span
 - (d) Cooling-side proportioning cycle : 1 to 100sec
- (2) Output
- : (a) Relay contact output : ① 250V AC, 3A (Resistive load)
 - ② Electrical life : 300,000 time or more (Rated load)
 - ③ Heating-side : 1c contact
 - ④ Cooling-side : 1a contact
 - (b) Voltage pulse output : 0/12V DC
(Allowable load resistance 600Ω or more)
 - (c) Continuous current output : 0 to 20mA DC, 4 to 20mA DC
(Allowable load resistance 600Ω or less)
 - (d) Continuous voltage output : 0 to 1V DC, 0 to 10V DC, 1 to 5V DC
(Allowable load resistance 1kΩ or more)

I. Heater break alarm function

- (1) Input : Current transformer input : CTL-6P-N *
CTL-12-S56-10L-N *
*Specify any of above
- (2) Display accuracy : $\pm 5\%$ of input value or 2A (Within the value whichever is the greater)
- (3) Setting range : 0.0 to 100.0 A
- (4) Display : Transmission type surface light emitting diode (LED) display (Red)
- (5) Output : Relay contact output : ① 250V AC, 1A (Resistive load)
② Electrical life : 50,000 time or more
(Rated load)
③ 1a contact

INDEX

CHARACTER INDEX

Various characters used in this instrument are displayed on 4-digit and 7-segment LEDs. However, alphabets are used mainly for these various characters to make their expression difficult on the 4-digit and 7-segment LEDs. Thus, "CHARACTER INDEX" are attached to make the meaning of various characters quickly understood and also to clarify on what pages these characters are described.

■ In order to understand the characters quickly:

Refer to the following conversion tables before checking the "Character index".

Conversion table

Normal display	$\bar{\quad}$ (Minus)	-1	1	2	3	4	5	6	7	8	9	0
7-segment display	$\bar{\quad}$	-1	1	2	3	4	5	6	7	8	9	0

A	B (b)	C	D (d)	E	F	G	H	I	J	K	L
A	b	C	d	E	F	G	H	I	J	K	L

M	N (n)	O (o)	P	Q (q)	R (r)	S	T	U (Lowercase)	V	W
m	n	o	p	q	r	s	t	u	v	w

X	Y	Z	' (Dash)	° (Degree)
x	y	z	'	°

■ How to use the character index

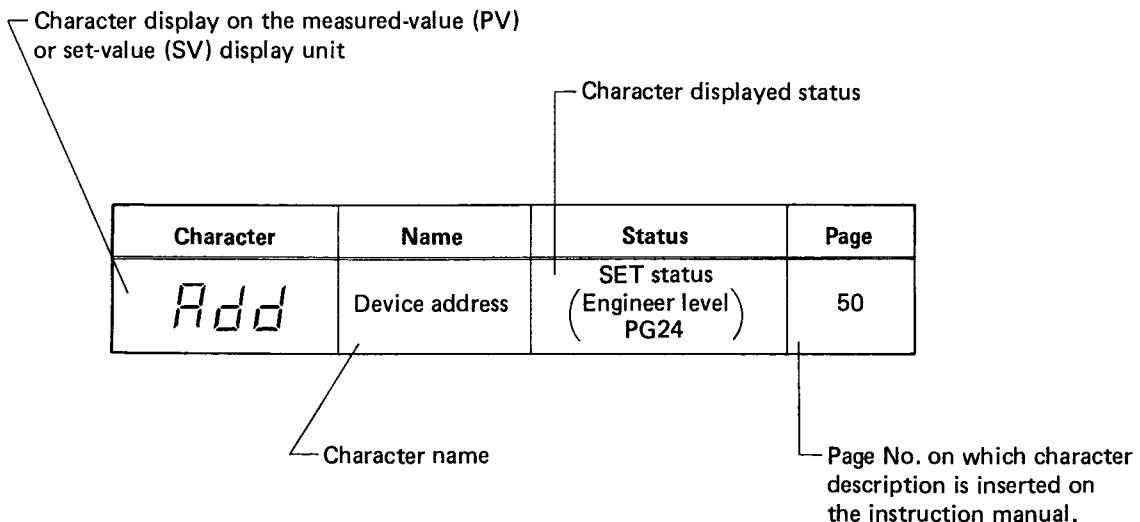

■ Character index

A (A)

Character	Name	Status	Page
<i>Add</i>	Device address	SET status (Engineer level) PG24	50
<i>Adv</i>	Feedback resistance adjustment	MODE status	33
<i>AEo1</i>	First alarm action selection at input abnormality	SET status (Engineer level) PG23	49
<i>AEo2</i>	Second alarm action selection at input abnormality		49
<i>AH1</i>	First alarm differential gap	SET status (Engineer level) PG14	42
<i>AH2</i>	Second alarm differential gap		42
<i>AHS</i>	High limit of analog output range	SET status (Engineer level) PG15	43
<i>AHo1</i>	First alarm hold action selection	SET status (Engineer level) PG23	49
<i>AHo2</i>	Second alarm hold action selection		49
<i>AL1</i>	First alarm	SET status (Operator level 2)	23
<i>AL2</i>	Second alarm		23
<i>ALS</i>	Low limit of analog output range	SET status (Engineer level) PG15	43
<i>ALF1</i>	First alarm timer setting	SET status (Engineer level) PG14	42
<i>ALF2</i>	Second alarm timer setting		42
<i>AO</i>	Analog output specification selection	SET status (Engineer level) PG15	43
<i>AOBE</i>	High limit of action selection at input abnormality	SET status (Engineer level) PG20	45
<i>ArE</i>	Memory area	Area status	27
	Area lock	SET status (Engineer level) PG40	51
<i>AS1</i>	First alarm action selection	SET status (Engineer level) PG23	49

<i>AS2</i>	Second alarm action selection	SET status (Engineer level) PG23	49
<i>ATb</i>	Auto-tuning (AT) bias	SET status (Engineer level) PG13	41
<i>ATU</i>	Auto-tuning (AT)	MODE status (PID/AT transfer)	28
<i>AUNE</i>	Low limit of action selection at input abnormality	SET status (Engineer level) PG20	45
<i>AUFo</i>	Auto mode	MODE status (AUTO/MAN transfer)	28

B (b)

Character	Name	Status	Page
<i>b</i>	TC input type B	Input type display	19
<i>bit</i>	Communication data bit configuration	SET status (Engineer level) PG24	50
<i>bP5</i>	Communication speed		50

C (C)

Character	Name	Status	Page
<i>CLS</i>	Feedback resistance adjustment closed-side output	MODE status	33
<i>COMP</i>	Computer mode	MODE status (LOC/COMP transfer)	29
<i>CT</i>	Current transformer input value (CT)	MONI status	21
<i>CY1</i>	Proportioning cycle	SET status (Engineer level) PG22	48
<i>CY2</i>	Cooling-side proportioning cycle		48

D (d)

Character	Name	Status	Page
d	Derivative time	SET status (Operator level 2)	23
db	Deadband		23
de	Neutral zone	SET status (Engineer level) PG16	43
de	Bar-graph display selection	SET status (Engineer level) PG17	44
df1	PV digital filter	SET status (Engineer level) PG10	40
df2	RS digital filter	SET status (Engineer level) PG11	40

E (E)

Character	Name	Status	Page
E	TC input type E	Input type display	19
End	Feedback resistance adjustment end	MODE status	33
Err1	Auto-tuning error	Display at abnormality	57
Err2	Input value error		57
Err3	RAM error		57
EUC1	First alarm energized/de-energized selection	SET status (Engineer level) PG23	49
EUC2	Second alarm energized/de-energized selection		49
EUF	External mode	MODE status Control area (LOC/EXT) transfer	28

H (H)

Character	Name	Status	Page
HbA	Heater break alarm	SET status (Engineer level) PG14	42

I (i)

Character	Name	Status	Page
i	Current input	Input type display	19
	Integral time	SET status (Operator level 2)	23
inP	Measured-value (PV) input type selection	SET status (Engineer level) PG20	45
inT	Interval time	SET status (Engineer level) PG24	50

J (J)

Character	Name	Status	Page
J	TC input type J	Input type display	19
JP	RTD input type JPt100		19

K (K)

Character	Name	Status	Page
K	TC input type K	Input type display	19
KEY	Key entry Valid/invalid during communication	SET status (Engineer level) PG24	50

L (L)

Character	Name	Status	Page
L	TC input type L	Input type display	19
LCU	Lock mode	MODE status Set data (ULCK/LCK) transfer	28
	Set date lock level	SET status (Engineer level) PG40	51
LoC	Local mode	MODE status (LOC/REM) transfer	28
	Local mode	MODE status Control area (LOC/EXT) transfer	28
	Local mode	MODE status (LOC/COMP) transfer	29

M(\bar{n})

Character	Name	Status	Page
$\bar{n}A\bar{n}$	Manual mode	MODE status (AUTO/MAN) transfer	28
$\bar{n}Y'$	Manipulated output value (MV) during output change	MONI status	20
$\bar{n}Y2'$	Manipulated output value (MV) during output change (cooling-side)		20

N(n)

Character	Name	Status	Page
n	TC input type N	Input type display	19

O(o)

Character	Name	Status	Page
oHH	Upper ON/OFF action differential gap	SET status (Engineer level) PG12	41
oHL	Lower ON/OFF action differential gap		41
oLH	Output limit (high limit)		41
oLL	Output limit (low limit)		41
$oooo$	Overscale	Display at abnormality	56
oPn	Feedback resistance adjustment open-side output	MODE status	33
ord	Decrease in output change rate limit	SET status (Engineer level) PG12	41
oru	Increase in output change rate limit		41
$o51$	Direct/reverse action selection	SET status (Engineer level) PG22	48

P(P)

Character	Name	Status	Page
P	TC input type PLII	Input type display	19
	Proportional band	SET status (Operator level 2)	23
Pb	PV bias	SET status (Engineer level) PG10	40
PC	Cooling-side proportional band	SET status (Operator level 2)	23
Pd	Hot/cold start selection	SET status (Engineer level) PG22	48
PdA	Start determination point		48
$PG10$	Parameter group 10	SET status (Engineer level) PG10	40
$PG11$	Parameter group 11	SET status (Engineer level) PG11	40
$PG12$	Parameter group 12	SET status (Engineer level) PG12	41
$PG13$	Parameter group 13	SET status (Engineer level) PG13	41
$PG14$	Parameter group 14	SET status (Engineer level) PG14	42
$PG15$	Parameter group 15	SET status (Engineer level) PG15	43
$PG16$	Parameter group 16	SET status (Engineer level) PG16	43
$PG17$	Parameter group 17	SET status (Engineer level) PG17	44
$PG20$	Parameter group 20	SET status (Engineer level) PG20	45
$PG21$	Parameter group 21	SET status (Engineer level) PG21	47
$PG22$	Parameter group 22	SET status (Engineer level) PG22	48
$PG23$	Parameter group 23	SET status (Engineer level) PG23	49
$PG24$	Parameter group 24	SET status (Engineer level) PG24	50
$PG40$	Parameter group 40	SET status (Engineer level) PG40	51

P0DP	Decimal point position selection	SET status (Engineer level) PG20	45
P0SH	High limit of input programmable range		45
P0SL	Low limit of input programmable range		45
PI d	PID control	MODE status (PID/AT transfer)	28
PLC	PV low input cut-off	SET status (Engineer level) PG10	40
PSn	Manual output at abnormality	SET status (Engineer level) PG12	41
PI	RTD input type Pt100	Input type display	19
P0S	Feedback resistance input value (POS)	MONI status	20
	Feedback resistance adjustment	MODE status	33
P0H	High limit of input abnormality determination point	SET status (Engineer level) PG20	45
PUn	Low limit of input abnormality determination point		45

S(S)

Character	Name	Status	Page
S	TC input type S	Input type display	19
SLH	Setting limit (high limit)	SET status (Engineer level) PG21	47
SLL	Setting limit (low limit)		47
Sqr	Square root extraction selection	SET status (Engineer level) PG20	45
STOP	Operation STOP	MODE status Operation (RUN/STOP) transfer	29
	Operation RUN/STOP display lock	SET status (Engineer level) PG40	51
SH'	Set-value (SV) during setting change	MONI status	20
SHr	Remote setting input value (RS)		21
SHrL	Setting change rate limit	SET status (Operator level 2)	23

R(r)

Character	Name	Status	Page
r	TC input type R	Input type display	19
rb	RS bias	SET status (Engineer level) PG11	40
REn	Remote mode	MODE status (LOC/REM) transfer	28
rinP	Remote setting (RS) input type selection	SET status (Engineer level) PG21	47
rPI	Control response designation parameter	SET status (Operator level 2)	23
rr	RS ratio	SET status (Engineer level) PG11	40
rUn	Operation execution (RUN)	MODE status Operation (RUN/STOP) transfer	29

T(T)

Character	Name	Status	Page
T	TC input type T	Input type display	19
TrE	SV tracking selection	SET status (Engineer level) PG21	47

U(U,u)

Character	Name	Status	Page
U	TC input type U	Input type display	19
ULCE	Unlock mode	MODE status Set data (ULCK/LCK) transfer	28
UUUU	Underscale	Display at abnormality	56

V(H)

Character	Name	Status	Page
H	Voltage input	Input type display	19

W(U)

Character	Name	Status	Page
U	TC input type W5Re/W26Re	Input type display	19

Y(Y)

Character	Name	Status	Page
Ybr	Action selection at feedback resistance break	SET status (Engineer level) PG16	43
YH5	Open/close output differential gap		43

Others

Character	Name	Status	Page
OC	°C	Input type display	19
OF	°F		19

2. INDEX

[A]

Abnormality	
• at input abnormality	
Action —	45, 56
Activation area —	56
Alarm action —	49
Alarm status —	56
• Input abnormality determination point	45, 56
• Manual output at —	41, 56
Alarm	
• — action	49
• — action at input abnormality	49
• Deviation —	49
• — differential gap	42
• — energized/de-energized	49
• Heater break —	42
• — hold action	49
• Process —	49
• — setting	23
• — timer	42
Analog output	
• — range	43
• — specification selection	43
Area lock	51
AT bias	41
Auto	
• — /manual transfer	28, 31
• — mode	28
Auto-tuning	
• — bias	41
• Requirements for —	35
• — transfer	28

[B]

Bar-graph display	44
Bias	
• AT —	41
• PV —	40
• RS —	40
Bit configuration	50

[C]

Circuit configuration	13
Cold start	36
Communication	
• — data bit configuration	50
• Key entry during —	50
• — speed	50
Computer mode	29
Control	
• — area	27, 31
• — area internal/external transfer	28
• — response designation parameter	23
Cooling-side	
• — proportional band	23
• — proportioning cycle	48
Current transformer input value (CT)	21

[D]

Deadband	23
Decimal-point position selection	45
Derivative time	23
Deviation alarm	49
Device address	50
Differential gap	
• Alarm —	42
• ON/OFF action —	41
• Open/close output —	43
Digital filter	
• RS —	40
• PV —	40
Direct/reverse action	48
Downscale	5

[E]

Energized/de-energized	49
Error	57
External mode	28

[F]

Fail	49, 57
Feedback resistance	
• Action selection at — (FBR) break	43
• — adjustment	32
• — input value (POS)	20

[H]

Heater break alarm	42
Hold action	49
Hot/cold start	36, 48
Hot start	36

[I]

Input abnormality	
• Action at —	45, 56
• Activation area at —	56
• Alarm action at —	49
• Alarm status at —	56
• — determination point	45, 56
Input programmable range	45
Input range	
• — display	19
• — table	7, 46
Input type display	19
Integral time	23
Interval time	50

[L]

Limit	
• Output —	41
• Output change rate —	41
• Setting —	47
• Setting change rate —	33
Local	
• — /computer transfer	29, 31
• — mode	28, 29
• — /remote transfer	28, 31
Lock mode	28

[M]

Manipulated output value display during output change	20
Manual mode	21, 28
Memory area	27
Measured-value (PV) input type	45

[N]	
Neutral zone	43
[O]	
ON/OFF action differential gap	41
Open/close output differential gap	43
Operation execution/stop	
• – display lock	51
• – transfer	29, 34
Operator level	22
Output	
• – change rate limit	41
• – limit	41
• Manipulated output value (MV) display during output change	20
Overlap	23
Overscale	56
[P]	
PID/auto-tuning transfer	28
Process alarm	49
Proportional band	23
Proportioning cycle	48
PV	
• – bias	40
• – digital filter	40
• – input type	45
[R]	
Ratio	40
Remote	
• – mode	28
• – setting input type	47
• – setting input value (RS)	21
RS	
• – bias	40
• – digital filter	40
• – input type selection	47
• – ratio	40
RTD input	7, 46
[S]	
Set data	
• – lock	28
• – lock level	51
• – unlock/lock transfer	28
Setting	
• – change rate limit	23
• – limit	47
Square root extraction	45
Start determination point	36, 48
SV tracking	47
[T]	
TC input	7, 46
Temperature input	7, 46
Timer	42
[U]	
Underscale	56
Unlock mode	28
Upscale	5
[V]	
Voltage input	7, 46

RKc® **RKC INSTRUMENT INC.**

IM900F01-E6

HEAD OFFICE: 16-6, KUGAHARA 5-CHOME, OHTA-KU TOKYO JAPAN
PHONE: 03-3751-9799 (+81 3 3751 9799)
TELEX : 0246-8818 RKCTOK J
CABLE : RKCRIKAROL
FAX : 03-3751-8585 (+81 3 3751 8585)