



Single-phase Thyristor Unit

THV-1

Instruction Manual

IMR01M01-E16

Thank you for purchasing this RKC product. In order to achieve maximum performance and ensure proper operation of the instrument, carefully read all the instructions in this manual. Please place the manual in a convenient location for easy reference.

SYMBOLS

WARNING : This mark indicates precautions that must be taken if there is danger of electric shock, fire, etc., which could result in loss of life or injury.

CAUTION : This mark indicates that if these precautions and operating procedures are not taken, damage to the instrument may result.

 : This mark indicates that all precautions should be taken for safe usage.

 : This mark indicates important information on installation, handling and operating procedures.

 : This mark indicates supplemental information on installation, handling and operating procedures.

 : This mark indicates where additional information may be located.



WARNING

- An external protection device must be installed if failure of this instrument could result in damage to the instrument, equipment or injury to personnel.
- All wiring must be completed before power is turned on to prevent electric shock, fire or damage to the instrument and the equipment.
- This instrument must be used in accordance with the specifications to prevent fire or damage to the instrument and the equipment.
- This instrument is not intended for use in locations subject to flammable or explosive gases.
- Do not touch high-voltage connections such as power supply terminals, etc. to avoid electric shock.
- When the withstand voltage test or each test is performed, please contact RKC sales office or the agent. If you make a mistake in the test method, the instrument failure may result.
- RKC is not responsible if this instrument is repaired, modified or disassembled by other than factory-approved personnel. Malfunction may occur and warranty is void under these conditions.



High temperature caution:
Do not touch the heat radiation fin while the power is turned on or just after the power is turned off as it may be at high temperatures. If touched, burning may result.

CAUTION

- This product is intended for use with industrial machines, test and measuring equipment. (It is not designed for use with medical equipment and nuclear energy plant.)
- This is a Environment A instrument. In a domestic environment, this instrument may cause radio interference, in which case the user may be required to take additional measures.

- Be sure to provide an appropriate surge control circuit respectively for the following:
 - If input/output or signal lines within the building are longer than 30 meters.
 - If input/output or signal lines leave the building, regardless the length.
- This product is manufactured on the assumption that it is mounted within a control panel. All high-voltage connections such as power supply terminals must be enclosed in the control panel to avoid electric shock to operating personnel.
- All precautions described in this manual should be taken to avoid damage to the instrument or equipment.
- All wiring must be in accordance with local codes and regulations.
- Always use this product at the rated power supply voltage, load current and power frequency.
- All wiring must be completed before power is turned on to prevent electric shock, instrument failure, or incorrect action.
- To prevent instrument damage or failure, protect the power line and the input/output lines with a protection device such as fuse, etc.
- If this product is used for phase control, higher harmonic noise may be generated. Therefore in this case, take such measures as separating the power line from the high-voltage line for load drive.
- Prevent metal fragments or lead wire scraps from falling inside instrument case to avoid electric shock, fire or malfunction.
- Tighten each terminal screw to the specified torque found in the manual to avoid electric shock, fire or malfunction.
- For proper operation of this instrument, provide adequate ventilation for heat dissipation.
- Do not connect wires to unused terminals as this will interfere with proper operation of the instrument.
- Turn off the power supply before cleaning the instrument.
- Do not use a volatile solvent such as paint thinner to clean the instrument. Deformation or discoloration may occur. Use a soft, dry cloth to remove stains from the instrument.
- To avoid damage to the instrument display, do not rub with an abrasive material or push the front panel with a hard object.

NOTICE

- This manual assumes that the reader has a fundamental knowledge of the principles of electricity, process control, computer technology and communications.
- The figures, diagrams and numeric values used in this manual are only for explanation purpose.
- RKC is not responsible for any damage or injury that is caused as a result of using this instrument, instrument failure or indirect damage.
- RKC is not responsible for any damage and/or injury resulting from the use of instruments made by imitating this instrument.
- Periodic maintenance is required for safe and proper operation of this instrument. Some components have a limited service life, or characteristics that change over time.
- Every effort has been made to ensure accuracy of all information contained herein. RKC makes no warranty, expressed or implied, with respect to the accuracy of the information. The information in this manual is subject to change without prior notice.
- No portion of this document may be reprinted, modified, copied, transmitted, digitized, stored, processed or retrieved through any mechanical, electronic, optical or other means without prior written approval from RKC.

1. CHECKING THE PRODUCT

When unpacking your new instrument, please confirm that the following items are included. If any item is missing, damaged, or if your manual is incomplete, please contact RKC sales office or the agent.

- | | |
|--|---|
| <ul style="list-style-type: none"> • THV-1: 1 unit • Instruction manual (IMR01M01-E16): 1 copy • Setting of Heater Break Alarm (IMR01M05-E□) [For THV-1 with optional function 1]: 1 copy • Short bar: 1 piece | <p>Accessories (optional)</p> <ul style="list-style-type: none"> • Setter for open loop control (potentiometer, knob and scale plate) • Fuse unit (fast-blow fuse [1 piece] and holder) • Output voltmeter (150 V span or 300 V span) • Connector (plug) |
|--|---|

 The short bar is connected to the input and power supply terminals.

2. CONFIRMATION OF THE MODEL CODE

Check whether the delivered product is as specified by referring to the following model code list. If the product is not identical to the specifications, please contact RKC sales office or the agent.

THV- 1 P Z □ - □ * □ N - □ (-□.....) *
 (1) (2) (3) (4) (5)(6) (7)

* The code for accessory will be more than one if the product has more than one accessory.

- (1) Power supply
 1: Single-phase 100 to 240 V AC
- (2) Control method
 PZ: Phase control/Zero-cross control (configurable)
- (3) Rated current
 020: 20 A 045: 45 A 080: 80 A
 030: 30 A 060: 60 A 100: 100 A
- (4) Input signal
 5: Voltage input: 0 to 10 V DC
 6: Voltage input: 1 to 5 V DC
 8: Current input: 4 to 20 mA DC
- (5) Optional function 1
 N: No heater break alarm, current limiter, constant current control and protection function for control of primary side of a transformer functions
 H: Heater break alarm, current limiter, constant current control and protection function for control of primary side of a transformer functions (The current limiter, constant current control and protection function for control of primary side of a transformer functions are not available when the Zero-cross control.)

- (6) Optional function 2
 N: No function
- (7) Accessories
 1: Setter for open loop control (potentiometer, knob and scale plate) [1 set] and Connector (plug)
 2: Setter for open loop control (potentiometer, knob and scale plate) [2 sets] and Connector (plug)
 3: Fuse unit for 20 A and 30 A (fast-blow fuse [1 piece] and holder [3 circuits type])
 4: Output voltmeter (150 V span) [For Phase control]
 5: Output voltmeter (300 V span) [For Phase control]
 6: Fuse unit for 20 A, 30 A, 45 A, 60 A, 80 A and 100 A (fast-blow fuse [1 piece] and holder [1 circuit type])
 7: Fuse unit (UL approved instrument) for 20A, 30A, 45A, 60A, 80A, and 100A (fast-blow fuse [1 piece] and holder [1 circuit type])
 9: Connector (plug)
- Combination example of accessories
 -1-3: Setter for open loop control [1 set] and Connector (plug) and Fuse unit

 To control the primary side of the transformer, it is recommended to purchase a THV-1 with a protection function for control of primary side of a transformer.

■ Accessories (Order Separately)

Code	Details	Code	Details
THVP-S01	Setter (potentiometer, knob and scale plate)	THVP-F60	Fast-blow fuse for 60 A (1 circuit type)
THVP-F21	Fuse unit for 20 A (fast-blow fuse [1 piece] and holder [3 circuits type])	THVP-FA0	Fast-blow fuse for 80 A/100 A (1 circuit type)
THVP-F31	Fuse unit for 30 A (fast-blow fuse [1 piece] and holder [3 circuits type])	THVP-F2B	Fast-blow fuse (UL approved instrument) for 20 A (1 circuit type)
THVP-F22	Fuse unit for 20 A (fast-blow fuse [1 piece] and holder [1 circuit type])	THVP-F3B	Fast-blow fuse (UL approved instrument) for 30 A (1 circuit type)
THVP-F32	Fuse unit for 30 A (fast-blow fuse [1 piece] and holder [1 circuit type])	THVP-F4B	Fast-blow fuse (UL approved instrument) for 45 A (1 circuit type)
THVP-F42	Fuse unit for 45 A (fast-blow fuse [1 piece] and holder [1 circuit type])	THVP-F6B	Fast-blow fuse (UL approved instrument) for 60 A (1 circuit type)
THVP-F62	Fuse unit for 60 A (fast-blow fuse [1 piece] and holder [1 circuit type])	THVP-F8B	Fast-blow fuse (UL approved instrument) for 80 A (1 circuit type)
THVP-FA2	Fuse unit for 80 A/100 A (fast-blow fuse [1 piece] and holder [1 circuit type])	THVP-FAB	Fast-blow fuse (UL approved instrument) for 100 A (1 circuit type)
THVP-F23	Fuse unit (UL approved instrument) for 20 A (fast-blow fuse [1 piece] and holder [1 circuit type])	THVP-V01	Output voltmeter (150 V span) [For Phase control]
THVP-F33	Fuse unit (UL approved instrument) for 30 A (fast-blow fuse [1 piece] and holder [1 circuit type])	THVP-V02	Output voltmeter (300 V span) [For Phase control]
THVP-F43	Fuse unit (UL approved instrument) for 45 A (fast-blow fuse [1 piece] and holder [1 circuit type])	THVP-C01	Connector (plug)
THVP-F63	Fuse unit (UL approved instrument) for 60 A (fast-blow fuse [1 piece] and holder [1 circuit type])	THVP-H01	Fuse holder for 20 A and 30 A (3 circuits type)
THVP-F83	Fuse unit (UL approved instrument) for 80 A (fast-blow fuse [1 piece] and holder [1 circuit type])	THVP-H02	Fuse holder for 20 A, 30 A and 45 A (1 circuit type)
THVP-FA3	Fuse unit (UL approved instrument) for 100 A (fast-blow fuse [1 piece] and holder [1 circuit type])	THVP-H03	Fuse holder for 60 A, 80 A and 100 A (1 circuit type)
THVP-F20	Fast-blow fuse for 20 A (3 circuits type)	THVP-H04	Fuse holder (UL approved instrument) for 20 A and 30 A (1 circuit type)
THVP-F2A	Fast-blow fuse for 20 A (1 circuit type)	THVP-H05	Fuse holder (UL approved instrument) for 45 A, 60 A, 80 A and 100 A (1 circuit type)
THVP-F30	Fast-blow fuse for 30 A (3 circuits type)		
THVP-F3A	Fast-blow fuse for 30 A (1 circuit type)		
THVP-F45	Fast-blow fuse for 45 A (1 circuit type)		

 Refer to the **10. Accessories (P. 29)** for the actual rated current for Fast-blow fuse to confirm the rating between Thyristor unit and Fast-blow fuse.

3. PARTS DESCRIPTION

The 20 A and 30 A types are used in the following figures for explanation, but the same explanations also apply to 45 A, 60 A, 80 A and 100 A types.

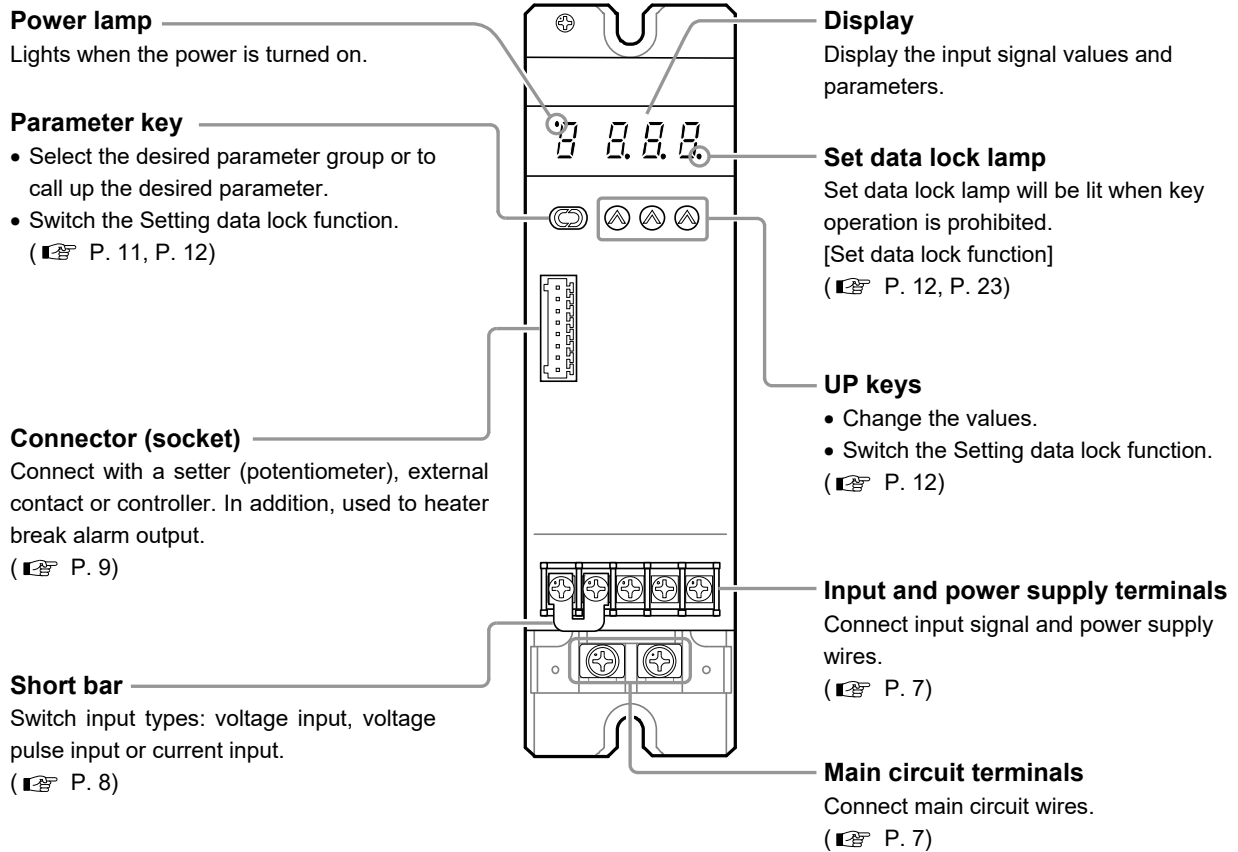

4. MOUNTING



WARNING

To prevent electric shock or instrument failure, always turn off the power before mounting or removing the instrument.

4.1 Mounting Environment

Avoid the following conditions when selecting the mounting location:

- Ambient temperature of less than 0 °C or more than 40 °C. (The rated current drops when the ambient temperature exceeds 40 °C.) The temperature inside the control panel increases due to heat generation of this instrument itself. Therefore, take into account full ventilation by mounting forced ventilation fans on the panel.
- Ambient humidity of less than 5 % or more than 95 %RH.
- Rapid changes in ambient temperature which may cause condensation.
- Corrosive or inflammable gases.
- Direct vibration or shock to the mainframe.
- Water, oil, chemicals, vapor or steam splashes.
- Excessive dust, salt or iron particles.
- Excessive induction noise, static electricity, magnetic fields or noise.
- Exposure to direct sunlight.
- Excessive heat accumulation.

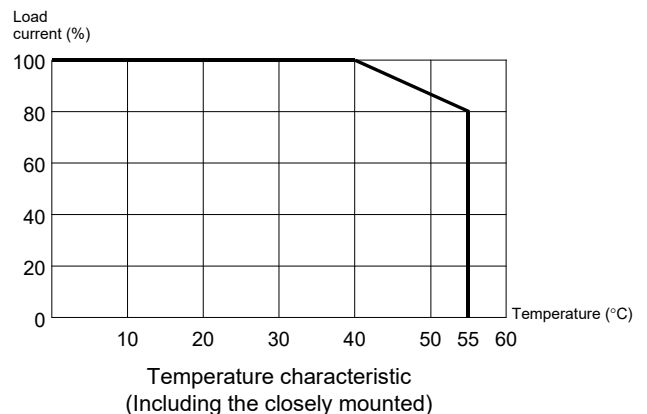

The temperature characteristic is common to the all types (20 A, 30 A, 45 A, 60 A, 80 A and 100 A).

4.2 Dimensions

■ 20 A and 30 A types

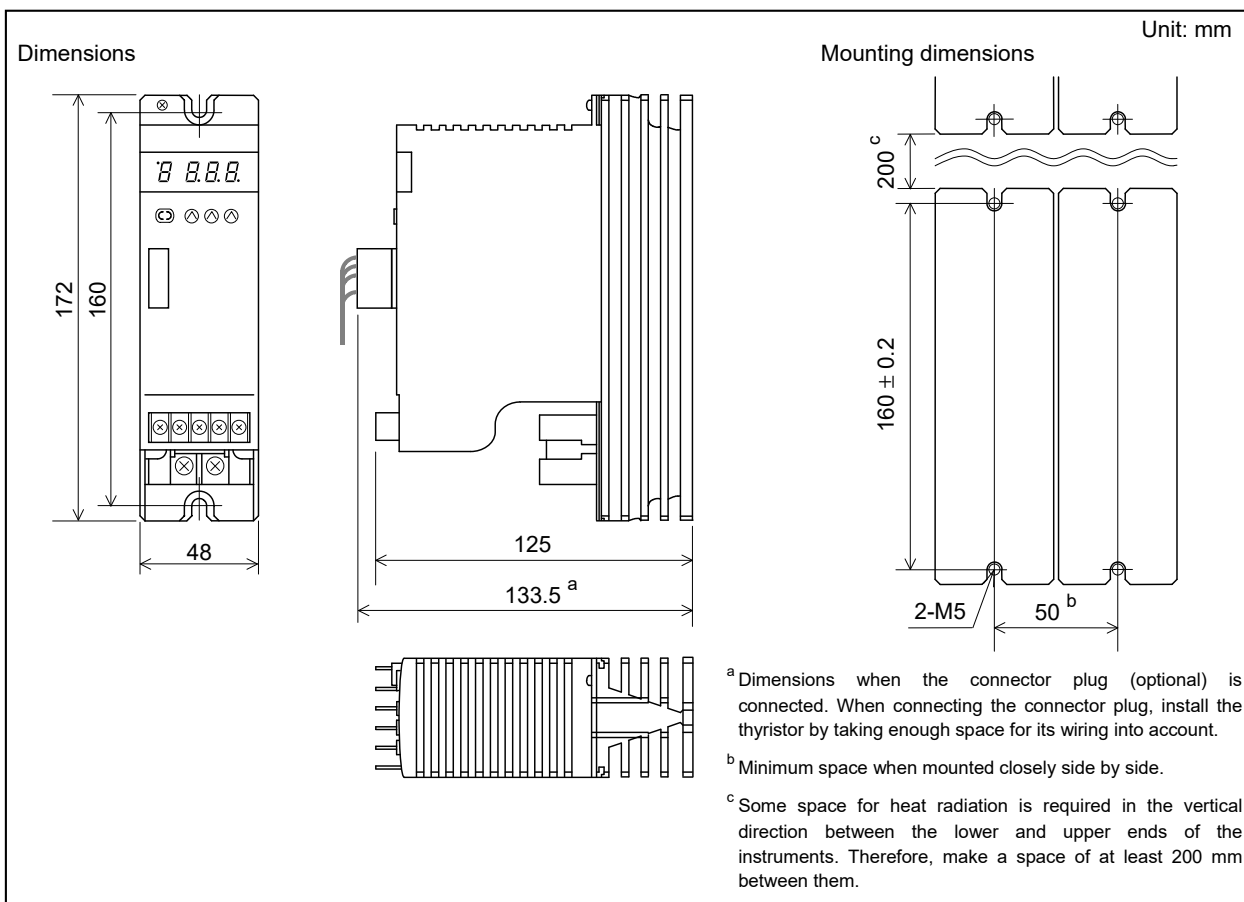

■ 45 A and 60 A types

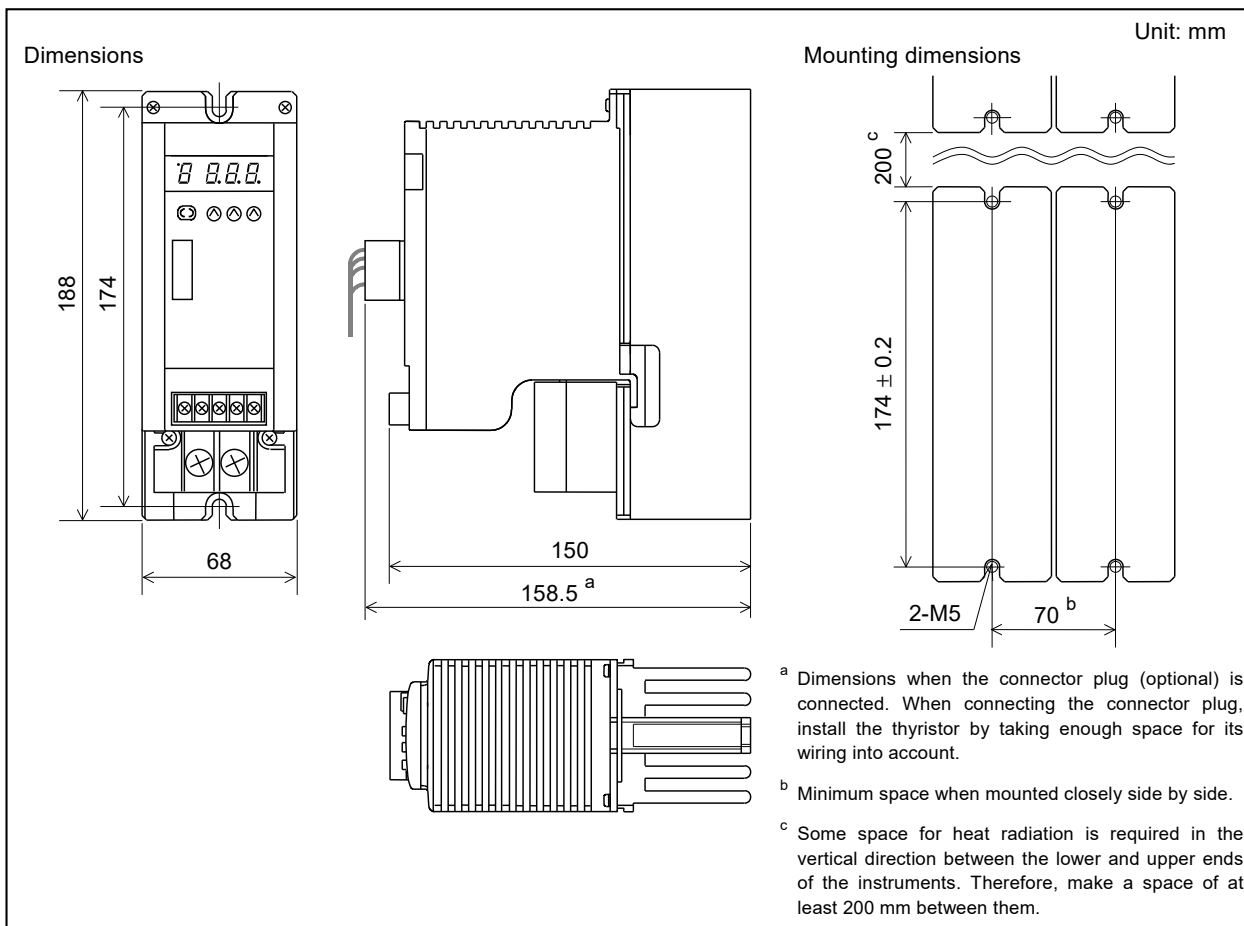

■ 80 A and 100 A types

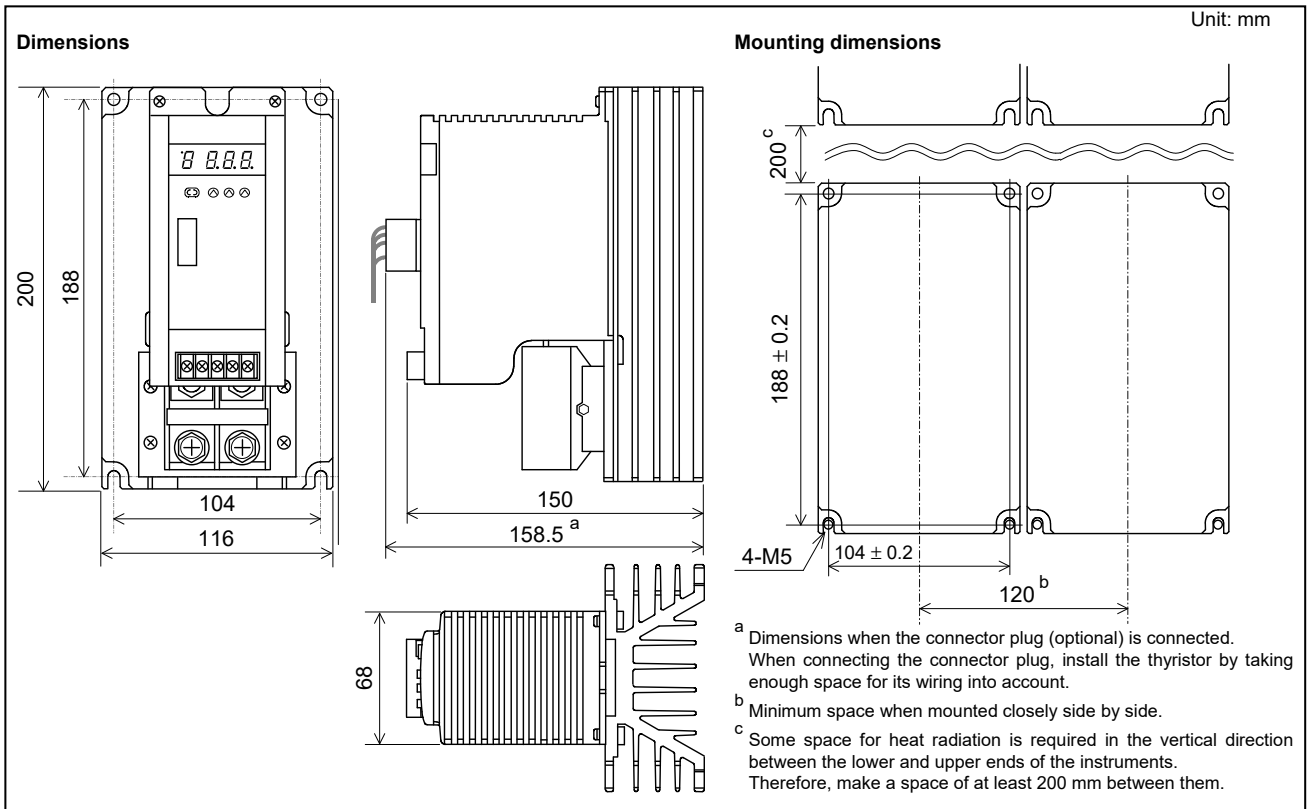

4.3 Mounting Procedures

The mounting direction of the instrument must be the same as the direction shown in the figure below to provide adequate ventilation space so that heat does not build up.

CAUTION

This unit generates heat. It is cooled by air convection when installed as shown. Failure to observe the instructions in 4.2 and 4.3 could cause damage to the instrument, equipment or injury to personnel. Precautions should be made for heat dissipation in the control cabinet.

1. Prepare the holes as specified in **4.2 Dimensions**.
2. Place the instrument in mounting position.
3. Insert the mounting screws into the holes, then tighten them with a screwdriver.

Recommended tighten torque: 1 N·m [10 kgf·cm]



Customer must provide the set of screws.

Screw type: Pan-head screws (Size: M5, Length: 10 mm)

■ 20 A, 30 A, 45 A and 60 A types

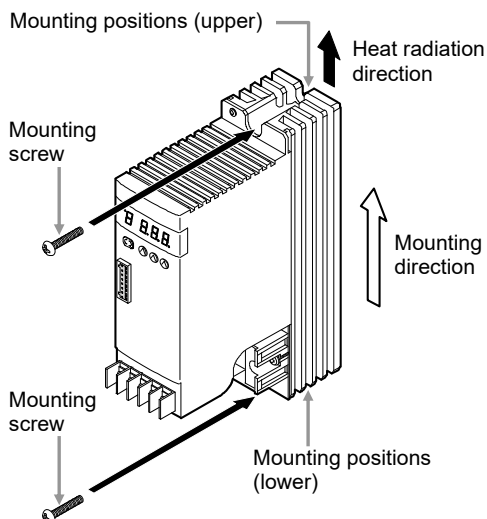

(The Figure shows the type of 20 A and 30 A. However, the mounting procedure is the same as for the type of 45 A and 60 A.)

■ 80 A and 100 A types

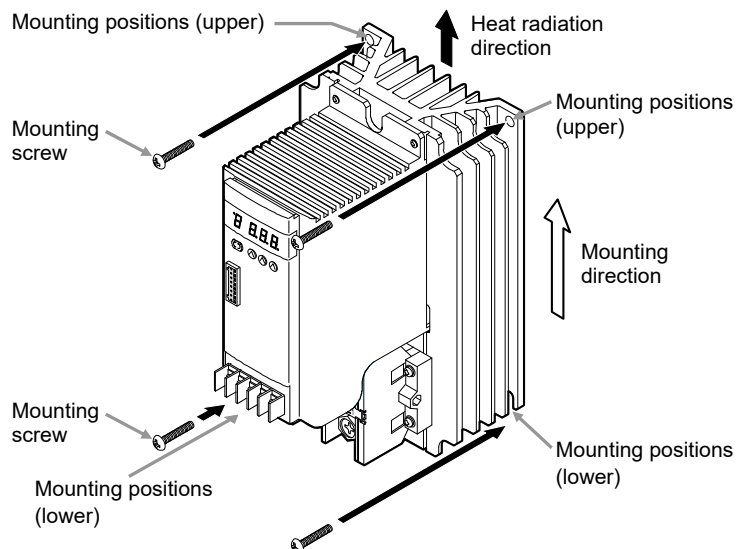

5. WIRING



WARNING

To prevent electric shock or instrument failure, do not turn on the power until all wiring is completed. Make sure that the wiring is correct before applying power to the instrument.

5.1 Wiring of Main Circuit

CAUTION

- Always conduct wiring so that the phase of the main circuit (2/T1) coincides with that of terminal No. 4 and the phase of the main circuit (1/L1), with that of terminal No. 5. Otherwise the instrument may not function properly or the load may be damaged.
- Caution for connecting a transformer to the load side of the instrument
 - When a protection function for control of primary side of a transformer is provided:
 - To conduct control of primary side of a transformer, make sure protection function for control of primary side of a control is set. Appropriately adjust the soft-start time for in case of secondary side breakdown depending on the operating condition.
 - When a protection function for control of primary side of a transformer is not provided:
 - If the action of the device is influenced by excessive current (inrush current, current due to flux saturation of transformer), use a transformer 1.25 T (magnetic flux density) or less.
 - Make sure soft-start time is appropriately set.

When connecting a transformer to the load side of this product, make sure that the current value of the primary side of the transformer is equal to or more than the minimum load current of this product. When the current value of the primary side of the transformer is less than the minimum load current value of this product, connect a bleeder resistor in parallel with the primary side of the transformer, and allow the current more than the minimum load current to flow.

Minimum load current: 0.6 A (20 A type) 1 A (30 A type or more)

When control is started on this instrument without connecting a load to the transformer, it may result in heat generation or failure of the transformer. Control must be always conducted with the load connected.

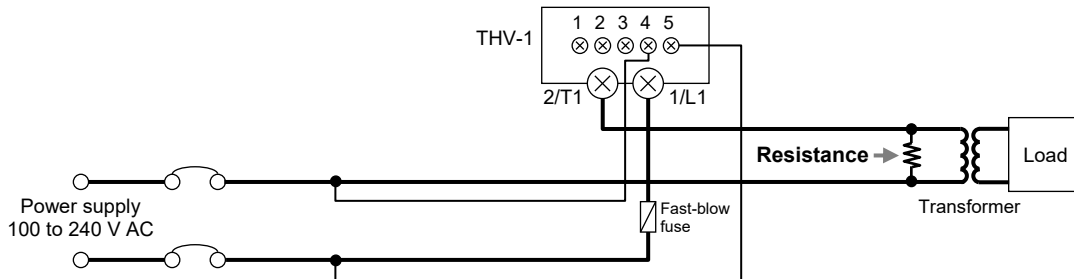

- Caution for connecting a noise filter to the load side of the instrument
 - When the control of this instrument is started without connecting a load in a configuration where a noise filter is connected to the load side of the instrument, a large surge may occur to the noise filter and a damage of the instrument may result. Control must be always conducted with the load connected.

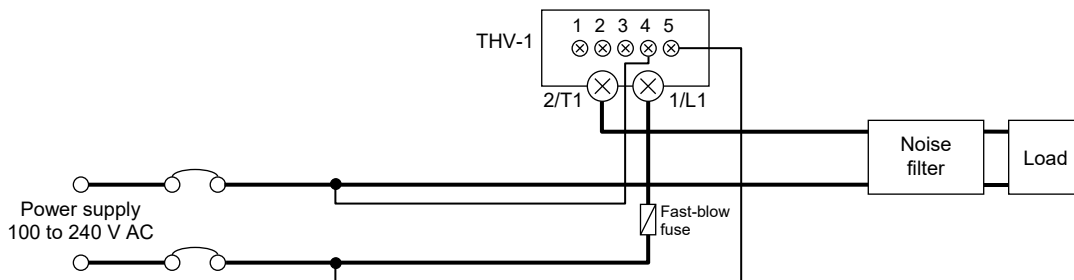

- THV-1 conforms to CE marking by using the noise filter.
 The noise filter specified: SOSHIN ELECTRIC CO., LTD.

20 A/30 A: LF2030A-NH	60 A: HF2060A-UP	100 A: HF2100A-UP
45 A: HF2050A-UP	80 A: HF2080A-UP	

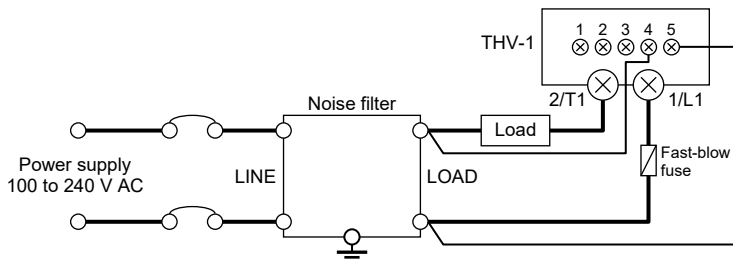

- There are neither fuses nor power switches in the power circuit of this instrument. Therefore install the fuses and switches near the instrument, if necessary.
- Use wires satisfying the rated current capacity.
- Firmly tighten each terminal screw with the tightening torque specified below. Otherwise, electric shock, fire or heat generation may result.
- When using a solderless terminal lug, use ring type.

Ring type solderless terminal size and tightening torque



Ring type solderless terminal

Item	Power terminals (4, 5)	Main circuit terminals (2/T1, 1/L1)		
		20 A and 30 A	45 A and 60 A	80 A and 100 A
ϕ	3.2 mm or more	4.3 mm or more	6.4 mm or more	8.4 mm or more
D (mm)	5.5 mm or less	9.5 mm or less	13.2 mm or less	22.6 mm or less
Recommended tightening torque	0.4 N·m (4 kgf·cm)	1.6 N·m (16 kgf·cm)	3.8 N·m (38 kgf·cm)	9.0 N·m (90 kgf·cm)

- Make sure that the any wiring such as solderless terminal is not in contact with the adjoining terminals.

Wiring diagram of main circuit

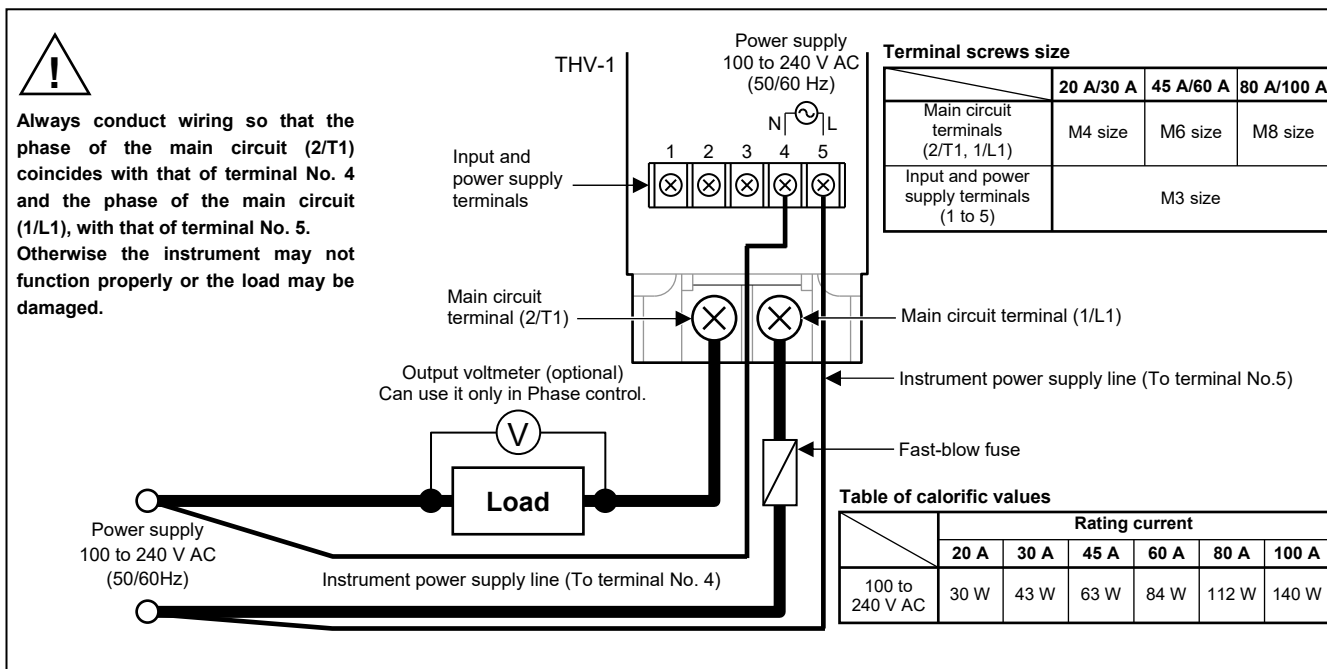

5.2 Wiring of Input Signal

■ Current input 4 to 20 mA DC, voltage input 0 to 10 V DC, 1 to 5 V DC and voltage pulse input 0/12 V DC

The input signal type can be changed by moving the short bar position. Any parameter change is not required for input type change.

CAUTION

- Firmly tighten each terminal screw with the tightening torque specified below. Otherwise, electric shock, fire or the generation of heat may result.
- When using a solderless terminal lug, use ring type.

Ring type solderless terminal size and tightening torque

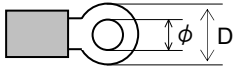

Ring type solderless terminal

Item	Input terminals (1, 2 and 3)
ϕ	3.2 mm or more
D (mm)	5.5 mm or less
Recommended tightening torque	0.4 N·m (4 kgf·cm)

Current input 4 to 20 mA DC

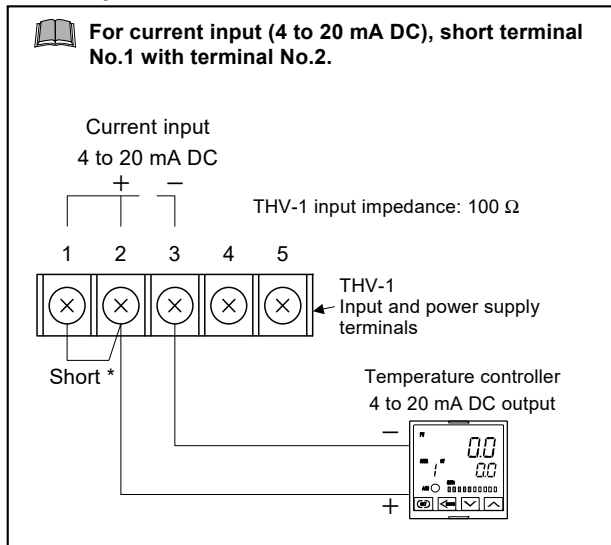

Voltage input 0 to 10 V DC, 1 to 5 V DC or Voltage pulse input 0/12 V DC

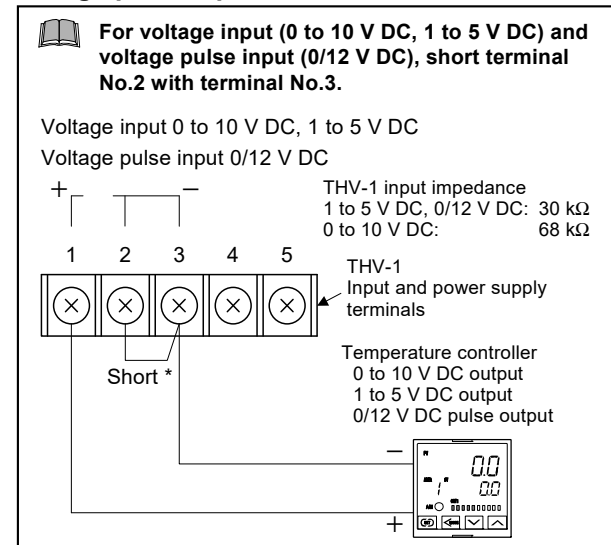

*The input signal type can be changed by moving the short bar position. Any parameter change is not required for input type change. However for a voltage input of 1 to 10 V DC, no input signal can be changed.

Application: Current input 4 to 20 mA DC (Series connection)

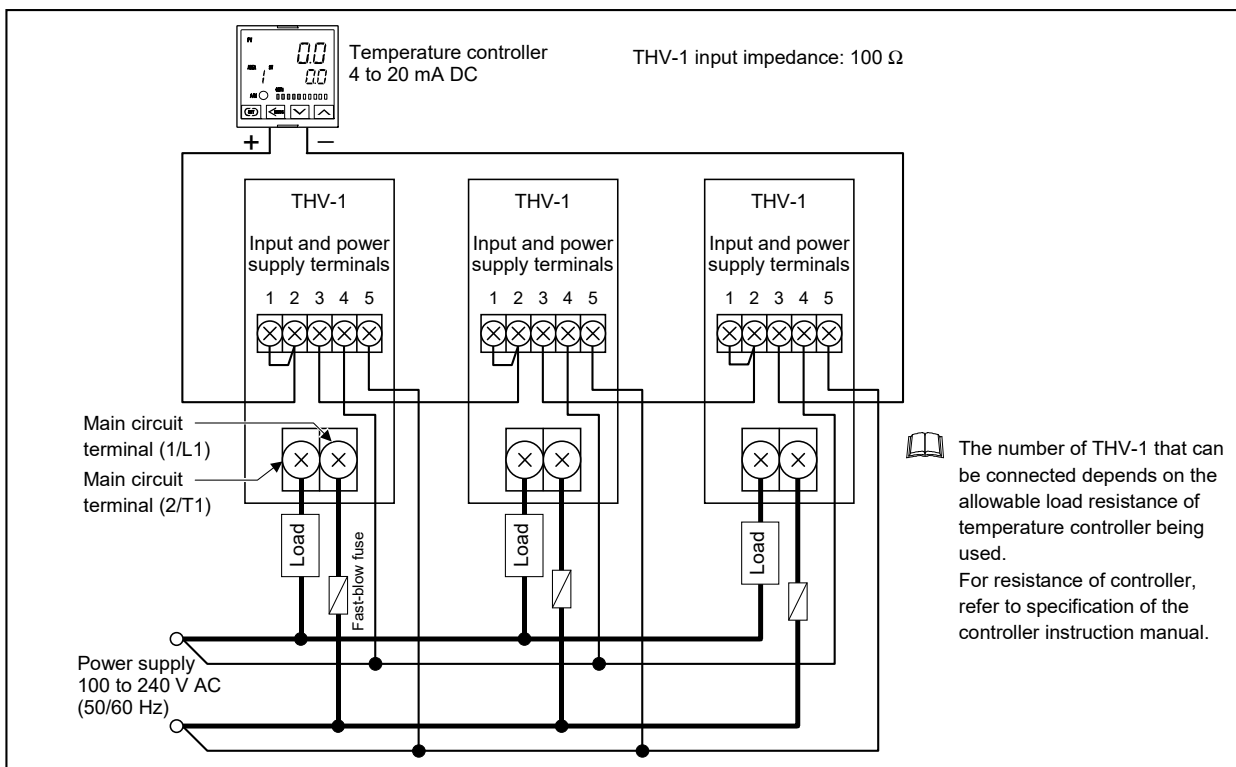

**Application: Voltage input 0 to 10 V DC, 1 to 5 V DC or Voltage pulse input 0/12 V DC
(Parallel connection)**

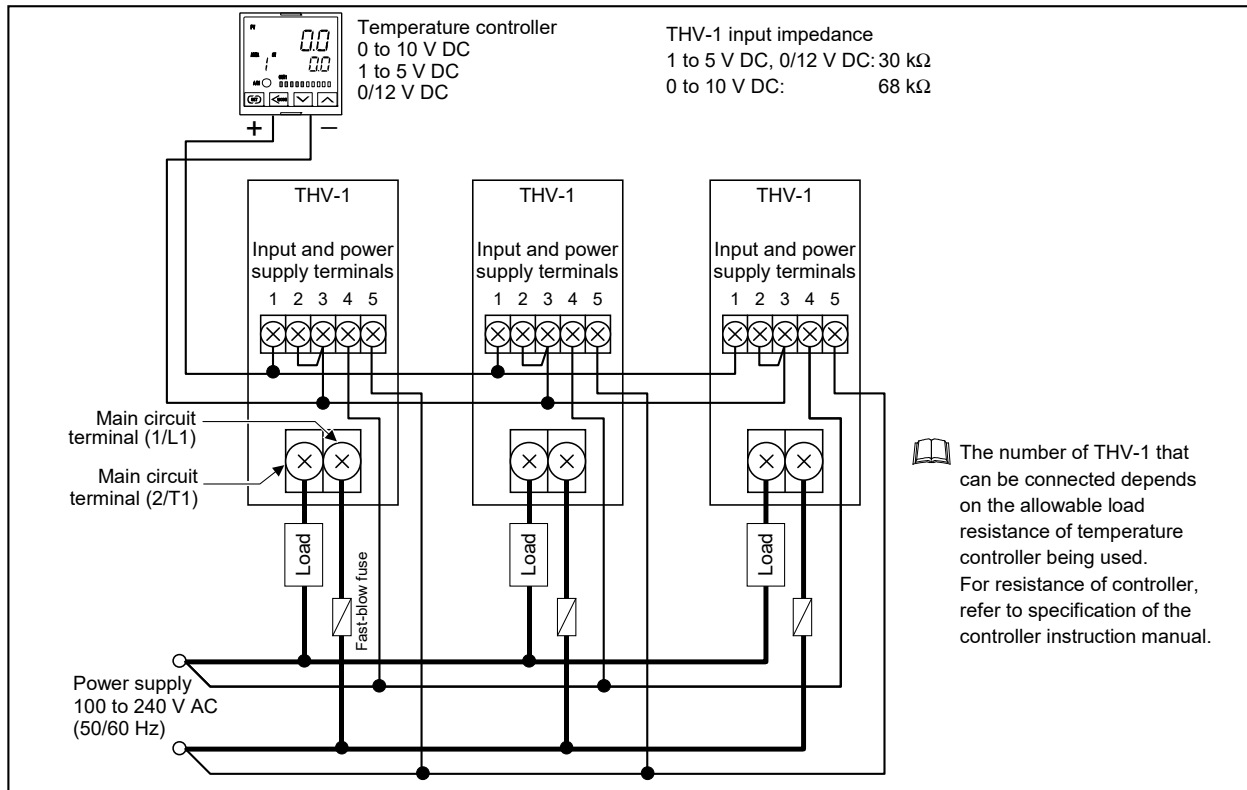

5.3 Wiring for connector

The connector is used for Contact input, Auto/Manual mode selection, External gradient setting, Heater break alarm 1 output or Heater break alarm 2 output. Use the optional connector (plug) for wiring.

Pin number and details

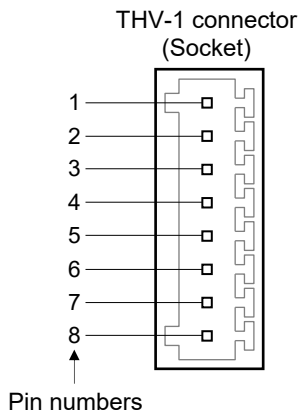

Pin number	Details
1	+5 V output
2	0 V
3	Gradient setting input (0 to 5 V input by the gradient setter)
4	External manual mode input (0 to 5 V input by the manual setter)
5	Auto/Manual mode transfer (contact open: auto mode) Shorting No.2 pin (0 V) with No.5 pin results in the Manual mode.
6	Open collector output (+): Used for output of the Heater break alarm 1 or Heater break alarm 2.
7	Open collector output (-): Used for output of the Heater break alarm 1 or Heater break alarm 2.
8	Unused

CAUTION

- Use stranded wire of size 0.14 to 0.5 mm² for the leadwires.
- Strip off the sheath from 8 mm from the leadwire end.

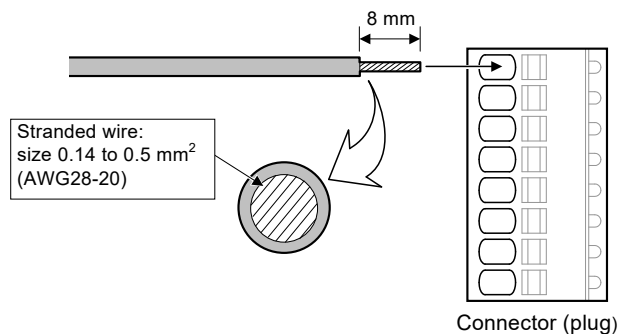

Contact input

For contact input, short connector pin No.2 with connector pin No.5.

To conduct ON/OFF control, set the value of the Output limiter high and the Output limiter low after wiring the contact input.

Contact closed: Output limiter high
Contact open: Output limiter low

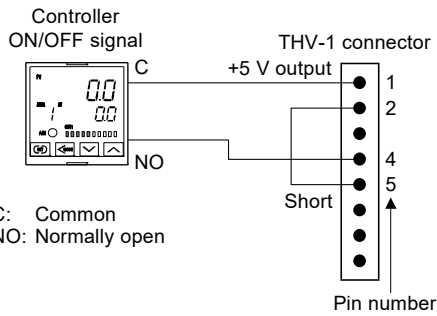

ON/OFF control

For ON/OFF control, short connector pin No.2 with connector pin No.5.

To set or change the output range, set High limit setter first. The set value of Low limit output value conforms to the value of High limit setter. The Low limit output value automatically changes when changing the set value of the High limit setter during the operation with the set value of the Low limit setter.

Low limit output value = Set value of high limit setter × Set value of Low limit setter

Example: Set value of the High limit setter: 80 %
Set value of the Low limit setter: 40 %
 $80 \% \times 40 \% = 32 \%$ Low limit output value 32 %

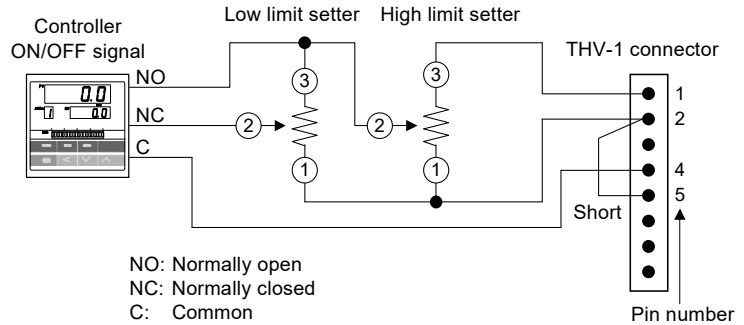

Manual mode

For manual setting, short connector pin No.2 with connector pin No.5.

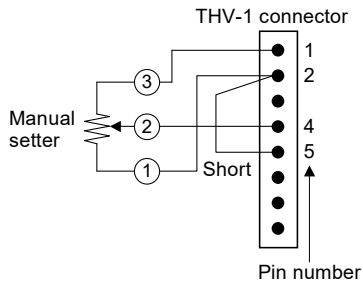

Auto mode* (With gradient setter)

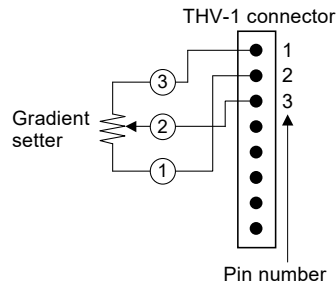

Auto/Manual mode selection *

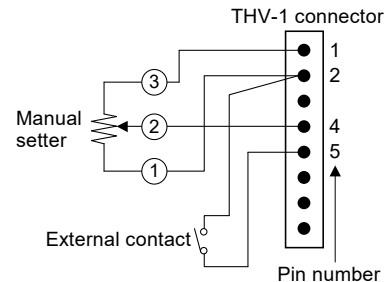

External contact closed: Manual mode
External contact open: Auto mode

* For input signal wiring, refer to ■ Current input 4 to 20 mA DC, voltage input 0 to 10 V DC, 1 to 5 V DC and voltage pulse input 0/12 V DC (P. 8).

Auto/Manual mode selection (With gradient setter)

The gradient setting is valid for both Auto mode and Manual mode.

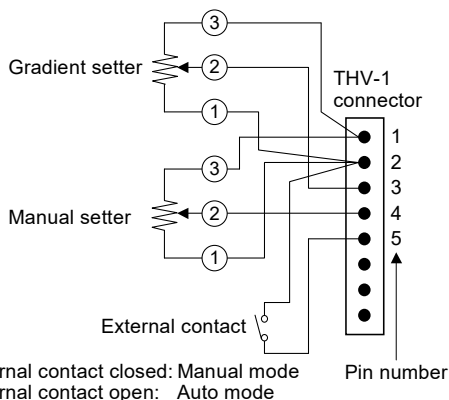

Heater break alarm output

A diode should be used and connected as show in the diagram, when using a relay.

When the power is turned on, the Heater break alarm output may be turned on for up to 0.5 ms. When an interlock circuit or any other related circuit is used, take a necessary measure externally for delaying the activation of the circuit more than 0.5 ms.

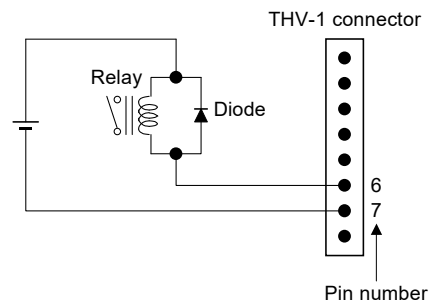

For input signal wiring, refer to ■ Current input 4 to 20 mA DC, voltage input 0 to 10 V DC, 1 to 5 V DC and voltage pulse input 0/12 V DC (P. 8).

6. SETTING

This chapter describes the display menus on the LED display.

6.1 Display Flowchart for Monitor and Setting Parameters

The instrument has two Monitor/Setting modes.

- Parameter group 1 includes parameters for both monitoring and setting such as Input signal monitor 1, Phase angle monitor, Phase/Zero-cross control selection, and others.
- Parameter group 2 includes parameters for monitoring such as Power frequency monitor, Input signal monitor 2, and others.

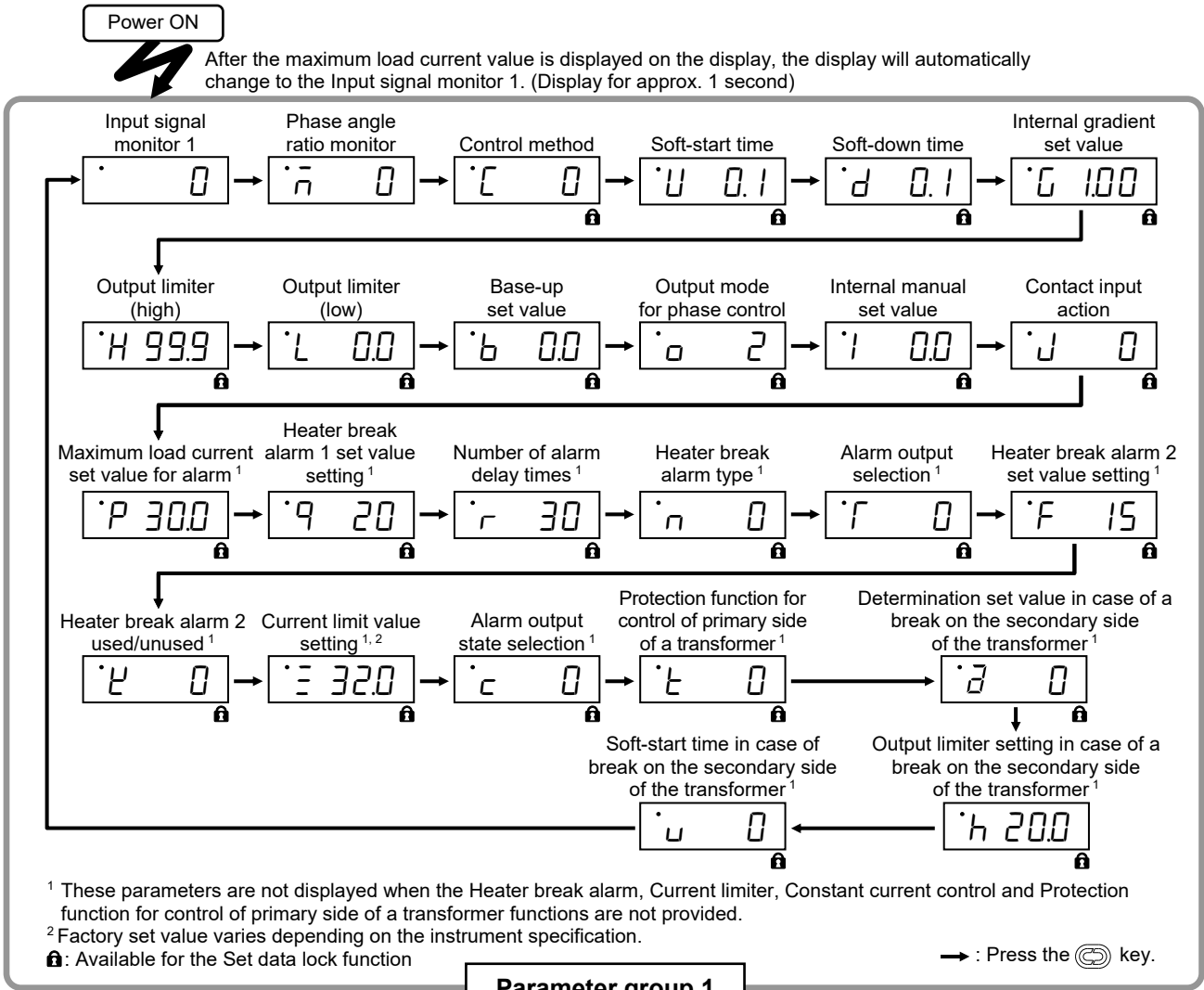

Press and hold the key for 2 seconds.

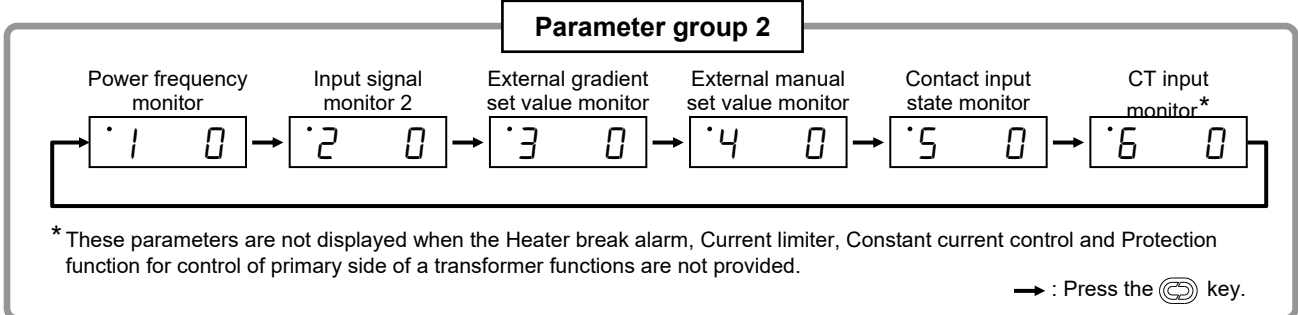

Parameters other than **Input signal monitor 1**, **Phase angle ratio monitor** and **CT input monitor** return to Input signal monitor 1 if key operation for more than one minute is not performed.

Error or alarm display

If any error or alarm occurs, the present display is changed to the error or alarm display.

Error display

6.2 Display Sequence

6.2.1 Selecting parameter group

After power-on to the instrument, the display automatically goes to Input signal monitor 1 in Parameter group 1. To go to Parameter group 2 display, press and hold the Parameter Key for 2 seconds.

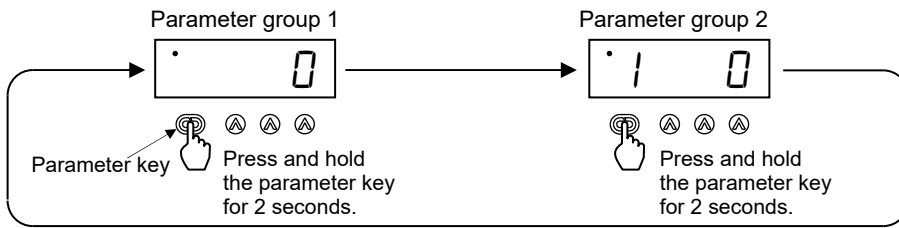

6.2.2 Changing parameter settings

Parameter key: Used for parameter calling up and set value registration.
 UP keys: Used to change the numeric value.

Example: Change control method (parameter group 1) from Phase control to Zero-cross control

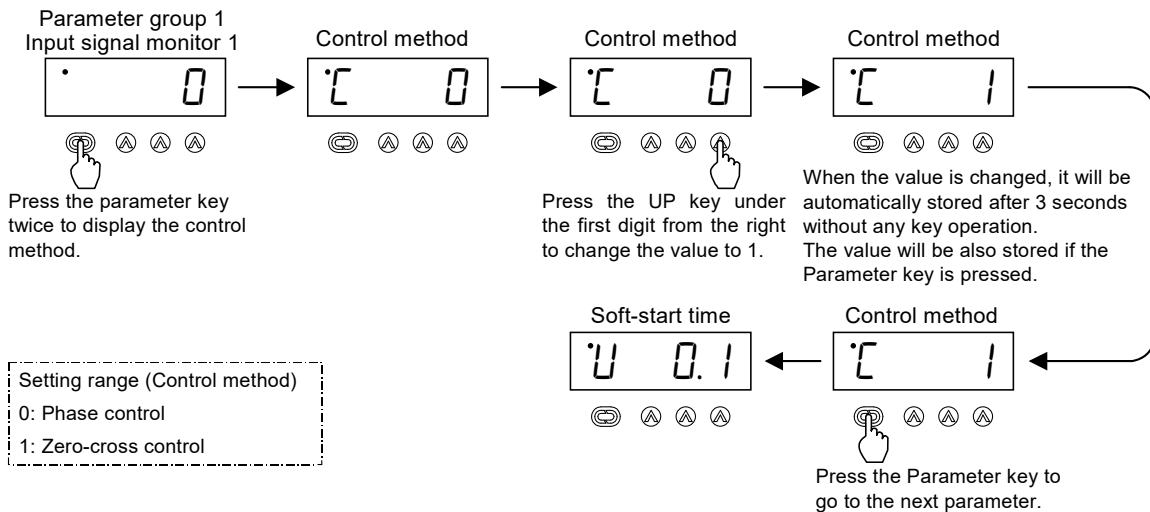

Other parameters can be set in the same way as the example above.

6.2.3 Setting method of Set data lock

Example: To validate the Set data lock function

1. Press and hold the Parameter key for 2 seconds to switch the Parameter group 1 to the Parameter group 2.

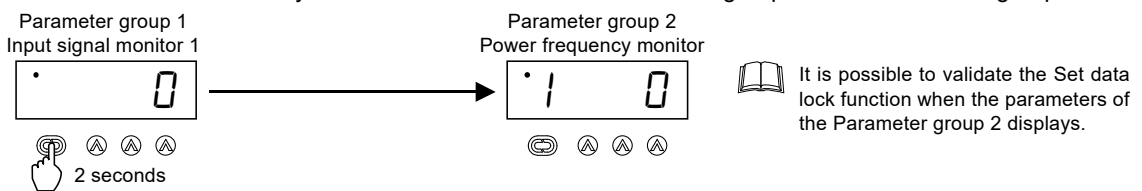

It is possible to validate the Set data lock function when the parameters of the Parameter group 2 displays.

2. Press and hold the Parameter key and the UP key at the right edge for 10 seconds to validate the Set data lock function.

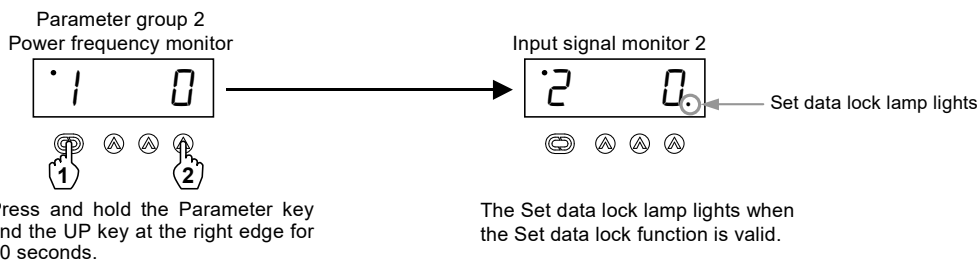

Press and hold the Parameter key and the UP key at the right edge for 10 seconds.

The Set data lock lamp lights when the Set data lock function is valid.

To invalidate the Set data lock function
 Press and hold the Parameter key and the UP key at the right edge for 10 seconds to invalidate the Set data lock function. It is possible to invalidate the Set data lock function when the Parameter group 1 or the Parameter group 2 displays.

- The UP key is not available when the Set data lock function is valid.
- It is possible to monitor the set values by using the Parameter key when the Set data lock function is valid.

6.2.4 Setting procedure of protection function for control of primary side of a transformer

The following parameters need to be adjusted to suit your system.

(If the factory set values satisfy the requirements, they can be used as they are)

After having the following parameters properly adjusted, enable the protection function for primary side of a transformer.

- Determination set value in case of a break on the secondary side of the transformer (a)
[Factory set value: 70 % of computed heater current value]
- Output limiter setting in case of a break on the secondary side of the transformer (h)
[Factory set value: 20.0 % of phase angle]
- Soft-start time in case of break on the secondary side of the transformer (u)
[Factory set value: 0.1 seconds]

■ Setting procedure

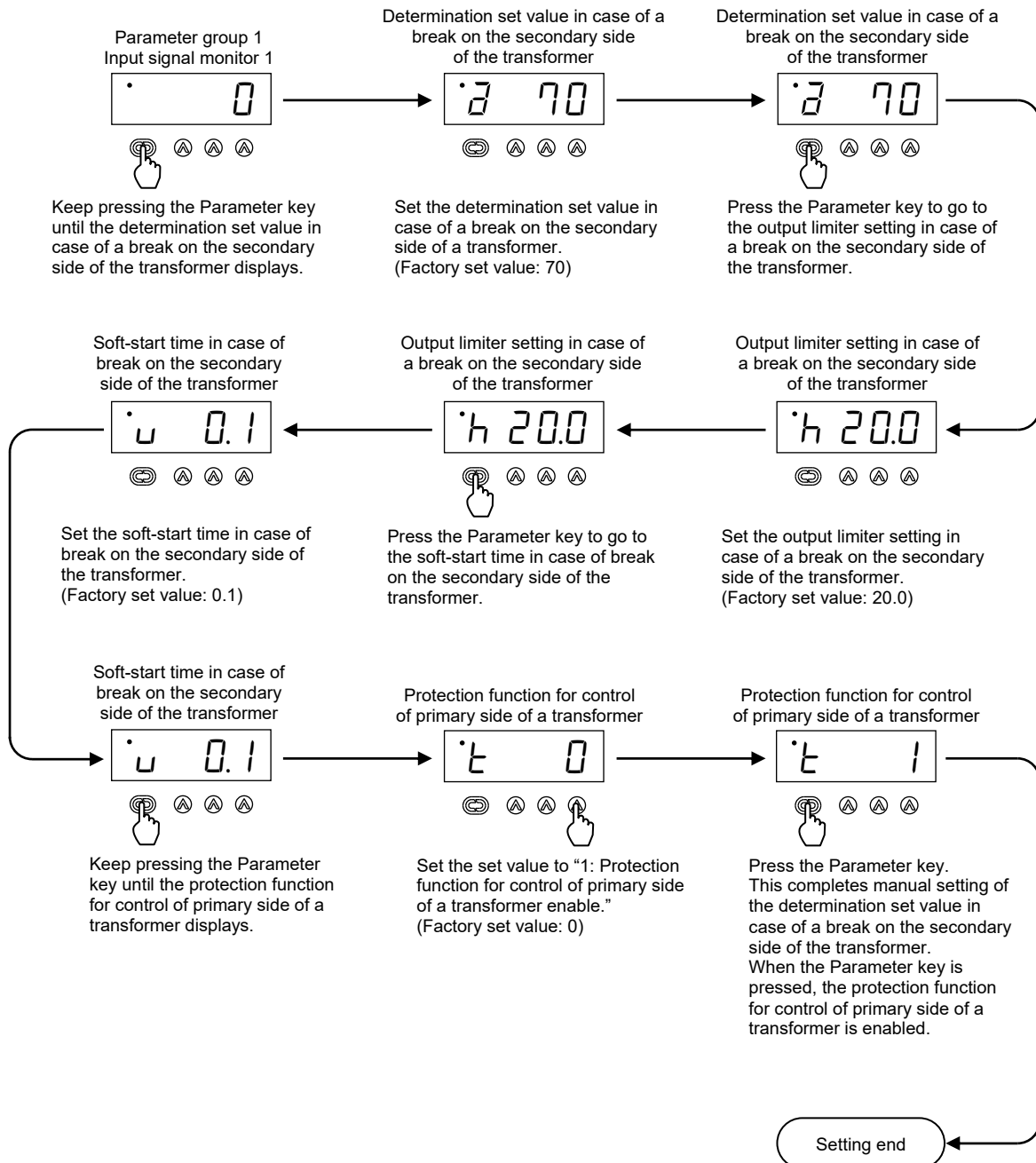

For details on changing the numeric value, refer to **6.2.2 Changing parameter settings (P. 12)**.

6.2.5 Parameter list

■ Parameter group 1

Name	Parameter Symbol	Display range or Setting range	Factory set value	Details	Reference page
Input signal monitor 1	No parameter	0 to 100 %	—	Displays one of the following values depending on the Control mode and the setting of Contact input action. <ul style="list-style-type: none"> • Input signal from controller • External manual set value • Internal manual set value For this selection, refer to item 7.1 Selecting Manual Mode Type and Input Signal Monitor 1.	P. 17
Phase angle ratio monitor	\bar{r} (M)	0 to 100 % When 0 %: phase angle 0° When 100 %: phase angle 180°	—		—
Control method	\bar{c} (C)	0: Phase control 1: Zero-cross control	0	Select the Control method.	P. 17
Soft-start time ^{1,2}	\bar{u} (U)	0.0 to 99.9 seconds	0.1	Set the Soft-start time.	P. 17
Soft-down time	\bar{d} (d)	0.0 to 99.9 seconds	0.1	Set the Soft-down time.	P. 17
Internal gradient set value	\bar{g} (G)	0.00 to 1.00 0.00: Internal gradient 0 % 1.00: Internal gradient 100 %	1.00	Set the Internal gradient set value.	P. 18
Output limiter high	\bar{h} (H)	0.0 to 99.9 %	99.9	Set the Output limiter high setting. ³	P. 18
Output limiter low ⁴	\bar{l} (L)	0.0 to 99.9 %	0.0	Set the Output limiter low. ³ The Base-up set value is effective only when the Output limiter low is set to 0.0.	P. 18
Base-up set value ⁴	\bar{b} (b)	0.0 to 99.9 %	0.0	Set the Base-up set value (output bias) of output. ⁵ The Base-up set value is effective only when the Output limiter low is set to 0.0.	P. 18
Output mode for phase control ⁶	\bar{o} (o)	0: Proportional phase angle to input 1: Proportional voltage to input 2: Proportional square voltage (electric power) to input 3: Constant current control ⁷	2	Select the output method for Phase control with linearity (R: resistor) load. The setting is invalid when Zero-cross control is selected.	P. 18
Internal manual set value	\bar{i} (I)	0.0 to 99.9 %	0.0	Set the Internal manual set value.	—

¹ If a load generating large rush current is used, thyristor break-down may occur when no soft-start time is appropriately set. Also in Zero-cross control, no rush current can be suppressed even if the soft-start time is set.

² If the protection function for control of primary side of a transformer is enabled, soft-start function is always operated for 0.1 second regardless of setting of soft-start time (U) at 0.0 seconds.

³ Output limiter high value must be equal or higher than Output limiter low.

⁴ These function can not be used together.

⁵ Base-up set value will not exceed the Output limiter high.

⁶ The Output mode setting is invalid when the Control method is Zero-cross control.

⁷ These parameters cannot be set when the Heater break alarm, Current limiter, Constant current control and Protection function for control of primary side of a transformer functions are not provided. If the rated current of thyristor differs from that maximum load current flowing through the heater when the Constant current control is selected, compensate for the difference by setting the gradient. Set the gradient so that the maximum heater load current will flow through the heater at an input signal of 100 % from the controller. (Refer to P. 19)

Name	Parameter Symbol	Display range or Setting range	Factory set value	Details	Reference page												
Contact input action	\mathcal{J} (J)	0: External manual mode ↔ Auto mode 1: Internal manual mode ↔ Auto mode 2: Internal manual mode (fixed)	0	Select the contact input action. This selection also affects the display of the Input signal monitor 1. Display of the Input signal monitor 1 <table border="1"> <thead> <tr> <th>Contact input action</th> <th>Contact open</th> <th>Contact close</th> </tr> </thead> <tbody> <tr> <td>0</td> <td>Input signal from controller</td> <td>External Manual set value</td> </tr> <tr> <td>1</td> <td>Input signal from controller</td> <td>Internal Manual set value</td> </tr> <tr> <td>2</td> <td colspan="2">Internal manual set value</td> </tr> </tbody> </table> (Refer to P. 14)	Contact input action	Contact open	Contact close	0	Input signal from controller	External Manual set value	1	Input signal from controller	Internal Manual set value	2	Internal manual set value		Refer to 7.1 on page 17.
Contact input action	Contact open	Contact close															
0	Input signal from controller	External Manual set value															
1	Input signal from controller	Internal Manual set value															
2	Internal manual set value																
Maximum load current set value for alarm ¹	\mathcal{P} (P)	0.0 to 32.0 A (20 A/30 A) ----- 0 to 55 A (45 A) ----- 0 to 70 A (60 A) ----- 0 to 90 A (80 A) ----- 0 to 110 A (100 A)	30.0 ----- 45 ----- 60 ----- 80 ----- 100	Sets the maximum heater current value. The value is used for the Heater break alarm 1 and Heater break alarm 2.	P. 20												
Heater break alarm 1 set value setting ^{1,2}	\mathcal{Q} (q)	0 to 100 % 0: Heater break alarm 1 unused	20	Set the Heater break alarm 1 set value. (Refer to page 18 for Heater break alarm.)	P. 20												
Number of alarm delay times ¹	\mathcal{R} (r)	0 to 99 times ³	30	Set the Number of alarm delay times. This setting is common to both Heater break alarm 1 and Heater break alarm 2.	P. 20												
Heater break alarm type ^{1,4}	\mathcal{N} (n)	0: Type 1 1: Type 2	0	When the Control method is Phase control, select an appropriate Heater break alarm.	P. 20												
Alarm output selection ¹	\mathcal{T} (T)	0: Heater break alarm 1 1: Heater break alarm 2 (heater deterioration) 2: Logical OR of heater break alarm 1 and heater break alarm 2 (heater deterioration)	0	Select the alarm type to be output from the digital output terminal of the connector.	P. 20												
Heater break alarm 2 set value setting ^{1,5} (Heater deterioration)	\mathcal{F} (F)	0 to 100 % 0: Heater break alarm 2 unused	15	Set the Heater break alarm 2 set value. (Refer to page 18 for Heater break alarm.)	P. 20												
Heater break alarm 2 used/unused ^{1,6}	\mathcal{K} (K)	0: Unused 1: Used	0	Set use/unuse of Heater break alarm 2. If set to "0: Unused," no alarm is output.	P. 20												

¹ These parameters are not displayed when the Heater break alarm, Current limiter, Constant current control and Protection function for control of primary side of a transformer functions are not provided.

² **When the Control method is Phase control, RKC recommends:**

- Set the Heater break set value to approximately 20 % of the Maximum load current value for heater break alarm Type 1.
- Set the Heater break set value to approximately 10 % of the Maximum load current value for heater break alarm Type 2.

When the Control method is Zero-cross control, RKC recommends:

- Set the Heater break alarm set value to approximately 80 % of the reading of current transformer input.
- Set the Heater break alarm set value to a slightly smaller value to prevent a false alarm when power supply variation is large.
- Set the Heater break alarm set value to a slightly larger value to detect a failure of one heater when more than one heaters are connected in parallel. But the set value should be less than the maximum reading of current transformer input.

³ The number for the delay times for Heater break alarm 2 is "the set value of Number of alarm delay times" multiplied by 10.

⁴ The setting is invalid when Zero-cross control is selected.

⁵ **When the Control method is Phase control and heater break alarm Type 1 is selected, RKC recommends:**

- Set the value must be equal or less than the heater break alarm 1 set value.

When the Control method is Phase control and heater break alarm Type 2 is selected:

- For the type 2, this item is not available. Set the "0: Heater break alarm 2 unused."

When the Control method is Zero-cross control, RKC recommends:

- If the alarm needs to be output before a heater break occurs, set the set value of heater break alarm 2 to any value slightly larger than that of heater break alarm 1.
- If the alarm needs to be output before thyristor break-down occurs, set the set value of heater break alarm 2 to any value slightly smaller than that of heater break alarm 1.

⁶ **When the heater break alarm type is Type 2:**

- For type 2, this item is not used. Set the set value of Heater break alarm 2 to "0: Unused."

Name	Parameter Symbol	Display range or Setting range	Factory set value	Details	Reference page
Current limit value setting ^{1, 2, 3}	= (Z)	0.0 to 32.0 A (20 A/30 A)	32.0	Set the Current limit value. If a current limit value is set to its maximum value, the Current limit function is deactivated. (Factory set value: The Current limiter function OFF)	P. 23
		0 to 55 A (45 A)	55		
		0 to 70 A (60 A)	70		
		0 to 90 A (80 A)	90		
		0 to 110 A (100 A)	110		
Alarm output state selection	C (c)	0: ON at alarm output 1: OFF at alarm output	0	Select whether the open-collector output is turned on or off when the Heater break alarm is output.	—
Protection function for control of primary side of a transformer ^{1, 4}	t (t)	0: Protection function for control of primary side of a transformer disable 1: Protection function for control of primary side of a transformer enable	0	Use to enable/disable protection function for control of primary side of a transformer. This setting must be "1: Protection function for control of primary side of a transformer enable" when protection function for control of primary side of a transformer is used.	P. 24
Determination set value in case of a break on the secondary side of the transformer ^{1, 4}	a (a)	0 to 100 % of computed heater current value	70	This is a setting to determine if break (momentary power failure) occurred on the secondary side of the transformer.	P. 24
Output limiter setting in case of a break on the secondary side of the transformer ^{1, 4}	h (h)	20.0 to 50.0 % of phase angle	20.0	Use to set output limiter to suppress control output in case of a break (momentary power failure) on the secondary side of the transformer.	P. 25
Soft-start time in case of break on the secondary side of the transformer ^{1, 4}	u (u)	0.1 to 99.9 seconds	0.1	Use to set the soft-start time when the instrument is recovered from a break (momentary power failure) on the secondary side of a transformer. This soft-start function is only activated when the instrument is recovered from a break on the secondary side of a transformer.	P. 25

¹ These parameters are not displayed when the Heater break alarm, Current limiter, Constant current control and Protection function for control of primary side of a transformer functions are not provided.

² If a load through which large rush current flows is used, the Current limit function cannot restrict the above current. In this case, use the Current limit function together with the Soft-start function.

³ The Current limiter function is not available when Zero-cross control is selected.

⁴ The Protection function for control of primary side of a transformer is not available when Zero-cross control is selected.

■ Parameter group 2

Name	Parameter Symbol	Display range	Details	Reference page
Power frequency monitor	1 (1)	0 to 99 Hz	Display the power frequency.	P. 19
Input signal monitor 2	2 (2)	0 to 100 %	Display the value of input signal from controller.	—
External gradient set value monitor	3 (3)	0 to 100 %	Display the External gradient set value.	—
External manual set value monitor	4 (4)	0 to 100 %	Display the External manual set value.	—
Contact input state monitor	5 (5)	0: Contact closed (Manual mode) 1: Contact open (Auto mode) ¹	Display the state of the Contact input.	—
CT input monitor ²	6 (6)	0.0 to 40.0 A (20 A/30 A)	Display the input value of current transformer.	—
		0 to 90 A (45 A)		
		0 to 120 A (60 A)		
		0 to 160 A (80 A)		
		0 to 200 A (100 A)		

¹ When "2: Internal manual mode (fixed)" is selected for Contact input action, the Auto/Manual mode is always in Manual mode whichever the contact state is.

² These parameters are not displayed when the Heater break alarm, Current limiter, Constant current control and Protection function for control of primary side of a transformer functions are not provided.

7. FUNCTIONS

7.1 Selecting Manual Mode Type and Input Signal Monitor 1

Displays one of the following values depending on the Control mode and the setting of Contact input action selection.

- Input signal from controller
- External manual set value (Input signal from external manual setter)
- Internal manual set value

, input signal from controller is always displayed on Input signal monitor 1 when the Contact input function is not used.

(The displayed item on Input signal monitor 1)

Contact input action selection	State of external contact	
	Contact closed (Manual mode)	Contact open (Auto mode)
0: External manual mode ↔ Auto mode	External manual set value	Input signal from controller
1: Internal manual mode ↔ Auto mode	Internal manual set value	Input signal from controller
2: Internal manual mode (fixed)	Internal manual set value	

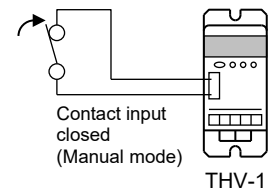

■ Select Manual mode type

Example: Select Manual mode with Internal manual set value.

1. Go to the parameter "Contact input action" in Parameter group 1. Set it to "1: Internal manual mode ↔ Auto mode."
2. The input signal from controller is displayed when the contact is open. The Internal manual set value is displayed when the contact is closed.

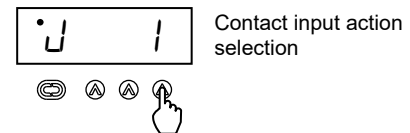

7.2 Control Method

■ Phase control

Phase control is to continuously control electric power supplied to a load by changing phase angle θ of AC voltage applied to the load. Each half-cycle has ON and OFF time.



■ Zero-cross control (Continuous)

Continuous Zero-cross control is to control electric power supplied to a load by turning the power supply voltage ON and OFF at the point of 0 V AC so that the high frequency noise can be suppressed compared with Phase control. This on and off time is typically measured in milliseconds.



■ Zero-cross control (Input synchronous type)

Input Synchronous type Zero-cross control is to turn the power supply ON and OFF synchronously with the pulse signal from a controller. This on and off time is typically measured in seconds.



7.3 Ramp Function (Soft-Start/Soft-Down Function)

Soft-start/Soft-down function gradually ramps up/down the output voltage to the demand level over the set time to prevent a sudden change in load or voltage.

The Soft-start/Soft-down time sets a period of time from 0 to 100 % or 100 to 0 %.

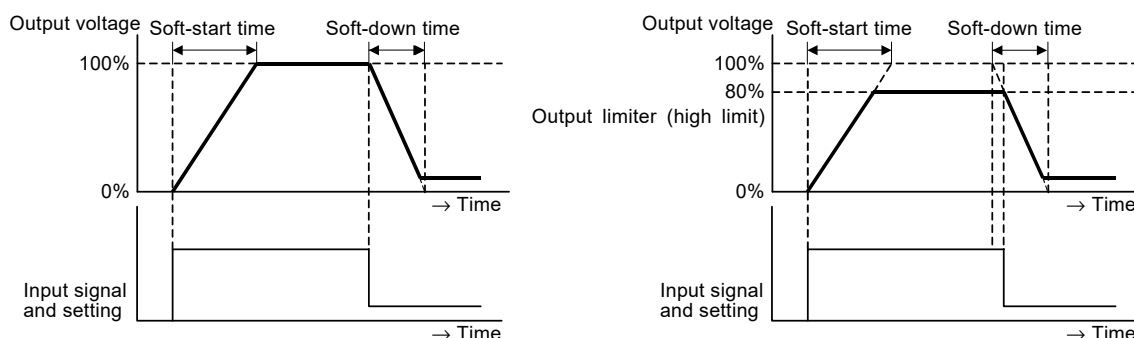

Soft-start/Soft-down action diagram

If a load generating large rush current is used, thyristor break-down may occur when no Soft-start time is appropriately set.

In Zero-cross control, no rush current can be suppressed even if the Soft-start time is set.

7.4 Gradient Setting Function

Gradient setting is a multiplier to be applied to output to the load to adjust the output value depending on an application.

The following two types of gradient setting are available.

- Internal gradient setting set by the THV-1 front keys
- External gradient setting set by the external gradient setter (external potentiometer)

The output value is adjusted by Gradient setting function as follows.

- (Output voltage computed by Auto mode) × (Internal gradient setting) × (External gradient set value)
- (Output voltage computed by Auto mode) × (Internal gradient set value)
- (Output by manual set value) × (Internal gradient set value) × (External gradient set value)



If it is necessary to make only the External gradient set value valid, set the Internal gradient set value to 1.00.

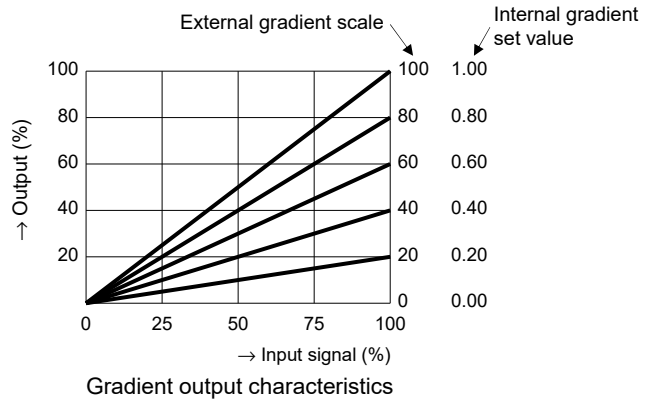

7.5 Output Limiter High and Low

This function limits the output range.

Output limiter function is related to other functions.

- Output limiter high and low has priority to the output value ¹ computed with Gradient setting function. The maximum output from the instrument will not exceed the Output limiter high and the minimum output will not go below the Output limiter low.
- Output limiter high has priority to the output value ² computed with Gradient setting and Base-up setting function. The maximum output from the instrument will not exceed the Output limiter high.
- When Output limiter low is not set to zero (0), the Base-up setting function is invalid.

¹ Output = (Input signal or Manual set value) × (Gradient set value)

² Output = (Input signal or Manual set value) × (Gradient set value) + (Base-up set value)

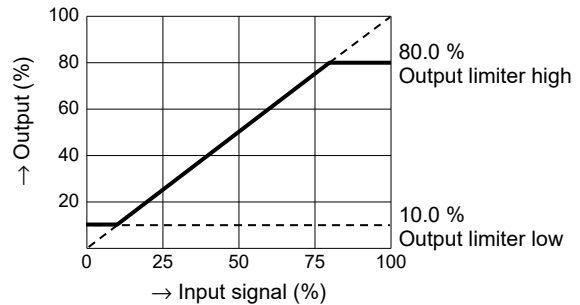

7.6 Base-Up Setting Function

Base-up setting function adds positive bias to the output value computed with Gradient setting function. Set the Base-up set value to a value not exceeding the Output limiter high.

- Base-up setting is valid only when Output limiter low is set to zero (0).
- Output limiter high has priority to the output value computed with Gradient setting and Base-up setting function. The maximum output from the instrument will not exceed the Output limiter high.

* Output = (Input signal or manual set value) × (Gradient set value) + (Base-up set value)

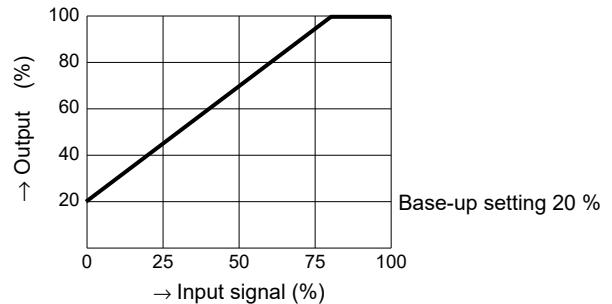

7.7 Output Mode for Phase Control

When Phase control is selected for a linearity (R: Resistance) load, one of the following four output types can be selected.

The factory set value is proportional square voltage (electric power) to input.

(The output mode setting is invalid when the Control method is Zero-cross control.)

Proportional phase angle to input

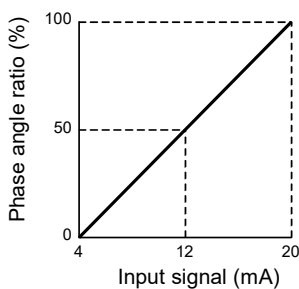

Proportional voltage to input

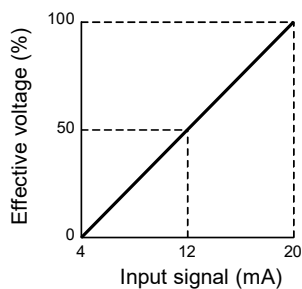

Proportional square voltage (electric power) to input

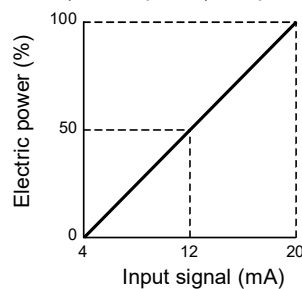

Constant current control

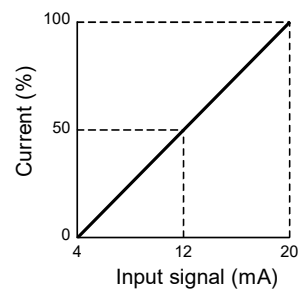

Continued on the next page.

Continued from the previous page.

■ Constant current control

This is the function used to keep the output current constant in proportion to the input signal. This function is effective when a heater with large resistance changes caused by temperature variations is used (such as tantalum, superkanthal, tungsten, platinum, or molybdenum). The maximum output current when the Constant current control function is used coincides with the rated current in the thyristor specification.

Operating condition	Stability
Power supply voltage variation $\pm 10\%$	$\pm 2\%$ of full scale
Load variation 2 times	

Caution for using Constant current control function

If the rated current of thyristor differs from that maximum load current flowing through the heater, compensate for the difference by setting the gradient. If there is the difference, a section where control is disabled may come into existence. A compensation example when there is a difference between the currents flowing through the thyristor and the heater is shown in the following.

Example: When used in the following condition

- Rated current of Thyristor: 30 A
- Maximum load current of heater: 15 A
- Input signal from controller: 4 to 20 mA DC
- Soft-start time setting: 0.0 seconds



The Soft-start function is activated during four cycles from load operation start even at a Soft-start time of 0.0 seconds.

When used without setting the gradient, the maximum heater load current becomes 15 A at an input signal of 12 mA. In this case, control is disabled if the input signal exceeds 12 mA.

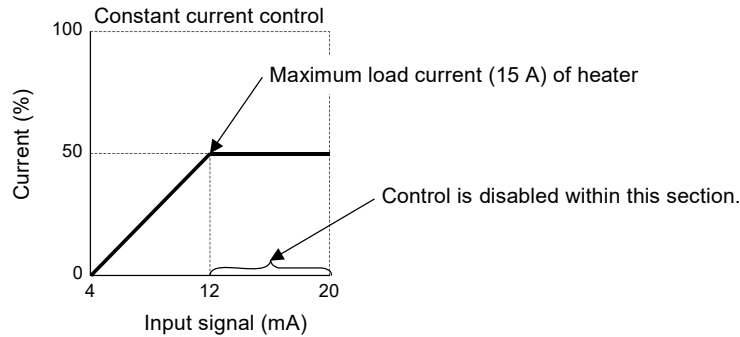

In this case, set the gradient to 50 % so that the maximum heater load current will become 15 A at an input signal of 20 mA. The gradient is valid even if internally set or set by the external gradient setter.

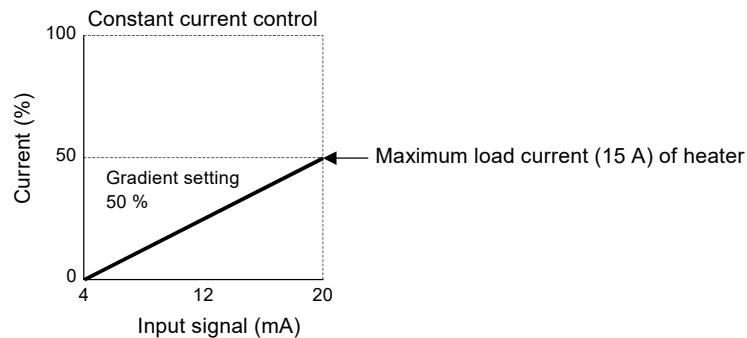

7.8 Automatic Power Frequency Detection and Power Frequency Monitoring Function

■ Automatic power frequency detection

The instrument automatically detects a power supply frequency (50 Hz or 60 Hz) when the power is turned on. Displays Error number 32 (Power frequency error 2) at the Error display when failed to detect Power supply frequency.

■ Power frequency monitoring function

This function monitors the power supply frequency and when it goes out of the detection range, the error message display appears. Displays Error number 16 (Power frequency error 1).

To confirm power supply frequency, switch to the Power frequency monitor by pressing the Parameter key at the Error display. (Only Power frequency monitor is available.)

- Detection range: 50 Hz = 45.0 to 54.9 Hz
- 60 Hz = 55.0 to 64.9 Hz



Error message will be cleared when power supply frequency returns to the detection range during the operation.

7.9 Heater Break Alarm Function

The Heater break alarm monitors the current flowing through the load by a dedicated current transformer (CT). The THV compares the measured value with the set values, and detects a fault in the heating or cooling circuit. In addition, there are several types of Heater break alarms depending on control methods and applications of these Heater break alarms. Read this chapter carefully to choose a suitable method and set an appropriate set value.

7.9.1 Common function for all types

■ Number of alarm delay times

To prevent producing a false alarm, the alarm function waits to produce an alarm status until the measured current by the CT is in an alarm range for the preset number of consecutive sampling cycles. The parameter of the Number of alarm delay times is to change the number of consecutive sampling cycles by 5-cycle increment.

Heater break alarm 1: (5 cycles) × (Number of alarm delay times)
 Heater break alarm 2: (5 cycles) × (Number of alarm delay times) × 10

Delays by the same number of cycles as that when the Number of alarm delay times is set at 1 even with the Number of alarm delay times set at 0.

7.9.2 Heater break alarm for Phase control

There are two alarm types (type 1 or type 2) available for Phase control.

(1) Type 1

Type 1 can be used as follows by using two Heater break alarm set values. (Refer to ■ Application)

Heater break alarm 1 set value: The alarm can be output when a heater break occurs by setting the Heater break alarm set value.

Heater break alarm 2 set value: This alarm set value can be used as an auxiliary alarm. For example, it can be used as a Heater deterioration alarm if set to any value slightly smaller than the Heater break alarm set value to output the alarm before a heater break occurs when the load current decreases due to heater deterioration, etc.



- The Heater break alarm of Type 1 cannot be used for heat generation substances such as noble metals making large resistance changes with temperature variations. In addition, it cannot be used for heat generation substances such as silicon carbide making resistance changes with temperature variations and a lapse of time.
- Type 1 cannot be used for any power supply waveforms other than a sine waveform.

■ How alarm is activated

• When heater current does not flow (Heater break, malfunction of the control device, etc.)

When the phase angle is equal to or more than 15% and the current transformer input value is equal to or less than the Heater break alarm set value for the preset number of consecutive sampling cycles, an alarm status is produced.

However, in order to prevent malfunctioning, it is so designed that no Heater break alarm occurs at an phase angle of less than 15% (less than 15% of maximum load current).

• When heater current can not be turned off (Thyristor break-down or permanent damage)

When the current transformer input value is equal to or greater than the Heater break alarm set value for the preset number of consecutive sampling cycles, an alarm status is produced.



The alarm will be turned off when the current transformer input value goes in and stays at non-alarm range for five consecutive cycles.

■ Application (When Heater break alarm 1 is used for detecting any broken heater or Heater break alarm 2, for detecting any deteriorated heater.)

Refer to the figure below for action by setting the set values for the following parameters:

- Maximum load current set value for alarm (P)*: 20 A
 - Heater break alarm 1 set value setting (Q): 20 %
 - Number of alarm delay times (r): 0 times
 - Heater break alarm type (n): 0: Type 1
 - Alarm output selection (r): 2: Logical OR of heater break alarm 1 and Heater break alarm 2
 - Heater break alarm 2 set value setting (F): 15 %
 - Heater break alarm 2 used/unused (L): 1: Used
 - Alarm output state selection (c): 0: ON at alarm output
- * Always set the maximum heater current value.

For details of Heater break alarm, refer to the separate **Setting Method of Heater Break Alarm (IMR01M05-E□)**.

Heater break alarm 1 set value

= (Maximum load current set value) × (Heater break alarm 1 set value)
 = 20 A × 20 % = 4 A

Heater break alarm 1 set value 4 A

Heater break alarm 2 set value

= (Maximum load current set value) × (Heater break alarm 2 set value)
 = 20 A × 15 % = 3 A

Heater break alarm 2 set value 3 A

The 4 and 3 amperes are set (deviation setting) to the high and low sides of the computed heater current value.

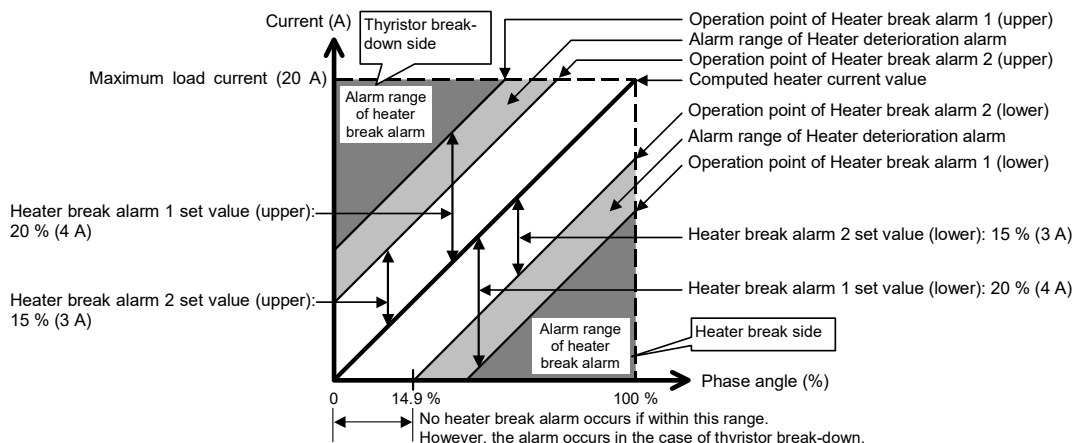

■ How alarm is checked

If the alarm occurs, the relevant error number is shown on the display unit. Therefore in this case, check the alarm contents.

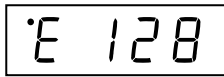

Error display

Error number	Description
128	Heater break alarm 1
256	Thyristor break-down
512	Heater break alarm 2 (heater deterioration)

For the Error display, refer to the **8. ERROR OR ALARM DISPLAY (P. 26)**.

(2) Type 2

Type 2 corresponds to a Heater break alarm when one heater is used. (Refer to ■ **Application**)

The Heater break alarm of Type 2 is used for heat generation substances such as noble metals making large resistance change with temperature variations.

No type 2 can be used when two or more heaters are used in parallel connection.

■ How alarm is activated

• When heater current does not flow (Heater break, malfunction of the control device, etc.)

When the phase angle is equal to or more than 15 % and the current transformer input value is equal to or less than the Heater break alarm set value for the preset number of consecutive sampling cycles, an alarm status is produced.

However, in order to prevent malfunctioning, it is so designed that no Heater break alarm occurs at an phase angle of less than 15 % (less than 15 % of maximum load current).

• When heater current can not be turned off (Thyristor break-down or permanent damage)

When the phase angle is 0 % and the current transformer input value is equal to or greater than the Heater break alarm set value for the preset number of consecutive sampling cycles, an alarm status is produced.

The alarm will be turned off when the current transformer input value goes in and stays at non-alarm range for five consecutive cycles.

■ Application

Refer to the figure below for action by setting the set values for the following parameters:

- Maximum load current set value for alarm (P)¹: 20 A
- Heater break alarm 1 set value setting (Q): 10 %
- Number of alarm delay times (r): 0 times
- Heater break alarm type (n): 1: Type 2
- Alarm output selection (r): 0: Heater break alarm 1
- Heater break alarm 2 set value setting (F)²: 0: Heater break alarm 2 unused
- Heater break alarm 2 used/unused (L)³: 0: Unused
- Alarm output state selection (c): 0: ON at alarm output

¹Always set the maximum heater current value.

²Always set the Heater break alarm 2 to "0: Heater break alarm 2 unused."

³Always set the Heater break alarm 2 used/unused to "0: Unused."

For details of heater break alarm, refer to the separate **Setting Method of Heater Break Alarm (IMR01M05-E□)**.

Heater break alarm 1 set value

$$= (\text{Maximum load current set value}) \times (\text{Heater break alarm 1 set value})$$

$$= 20 \text{ A} \times 10 \% = 2 \text{ A}$$

Heater break alarm 1 set value 2 A



Set the Heater break alarm 1 set value to approximately 10 % of the maximum load current value. Do not set the Heater break alarm set value to more than 15 %.

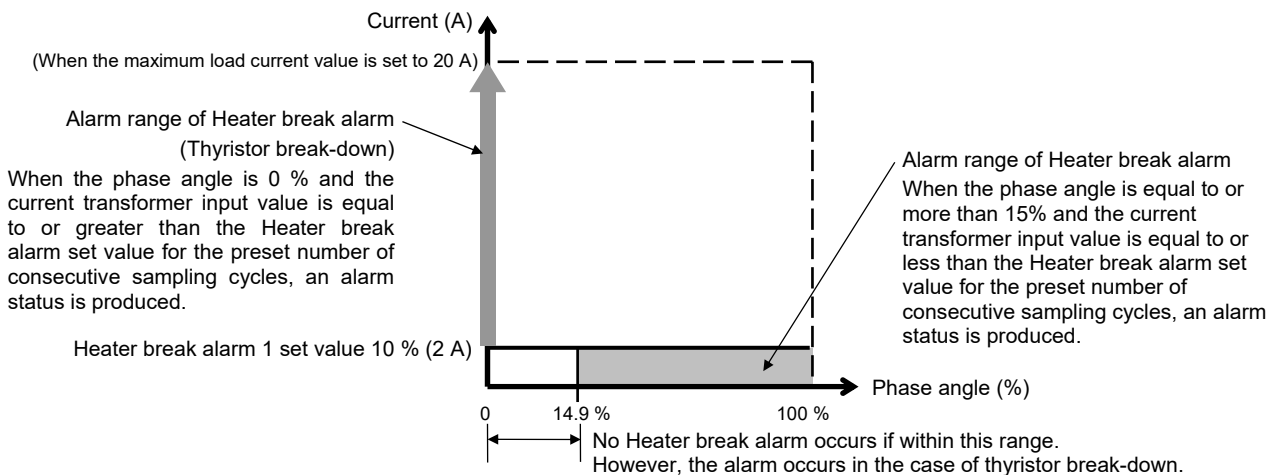

■ How alarm is checked

If the alarm occurs, the relevant error number is shown on the display unit. Therefore in this case, check the alarm contents.

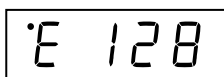

Error display

Error number	Description
128	Heater break alarm 1
256	Thyristor break-down

For the Error display, refer to the **8. ERROR OR ALARM DISPLAY (P. 26)**.

7.9.3 Zero-cross control

The following usage is available in Zero-cross control. (Refer to ■ **Application**)

Heater break alarm 1 set value: The alarm can be output when a heater break occurs by setting the Heater break alarm set value.

Heater break alarm 2 set value: This alarm set value can be used as an auxiliary alarm.

For example, it can be used as a Heater deterioration alarm if set to any value slightly larger than the Heater break alarm set value to output the alarm before a Heater break alarm occurs when the load current decreases due to heater deterioration, etc.

■ How alarm is activated

• When heater current does not flow (Heater break, malfunction of the control device, etc.)

When the control output is ON and the current transformer input value is equal to or less than the Heater break alarm set value for the preset number of consecutive sampling cycles, an alarm status is produced.

• When heater current can not be turned off (Thyristor break-down or permanent damage)

When the control output is OFF and the current transformer input value is equal to or greater than the Heater break alarm set value for the preset number of consecutive sampling cycles, an alarm status is produced.



The alarm will be turned off when the current transformer input value goes in and stays at non-alarm range for five consecutive cycles.

■ Application (When Heater break alarm 1 is used for detecting any broken heater or Heater break alarm 2, for detecting any deteriorated heater.)

Refer to the figure below for action by setting the set values for the following parameters:

- Maximum load current set value for alarm (P)*: 20 A
- Heater break alarm 1 set value setting (Q): 80 %
- Number of alarm delay times (r): 0 times
- Alarm output selection (r): 2: Logical OR of Heater break alarm 1 and Heater break alarm 2
- Heater break alarm 2 set value setting (F): 85 %
- Heater break alarm 2 used/unused (L): 1: Used
- Alarm output state selection (c): 0: ON at alarm output

* Always set the maximum heater current value.



For details of Heater break alarm, refer to the separate **Setting Method of Heater Break Alarm (IMR01M05-E□)**.

Heater break alarm 1 set value

$$= (\text{Maximum load current set value}) \times (\text{Heater break alarm 1 set value})$$

$$= 20 \text{ A} \times 80 \% = 16 \text{ A}$$

Heater break alarm 1 set value 16 A

Heater break alarm 2 set value

$$= (\text{Maximum load current set value}) \times (\text{Heater break alarm 2 set value})$$

$$= 20 \text{ A} \times 85 \% = 17 \text{ A}$$

Heater break alarm 2 set value 17 A

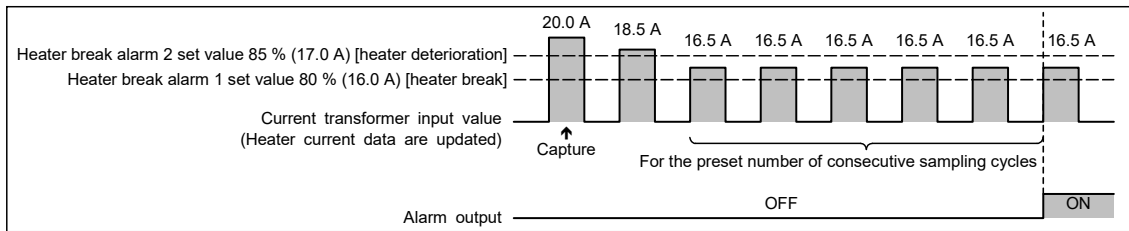

Heater deterioration

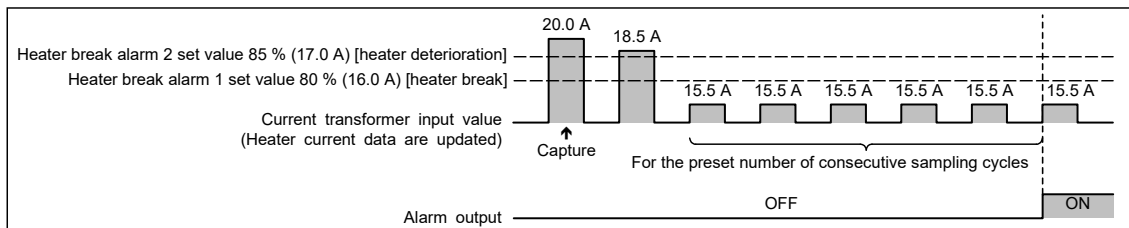

Heater break

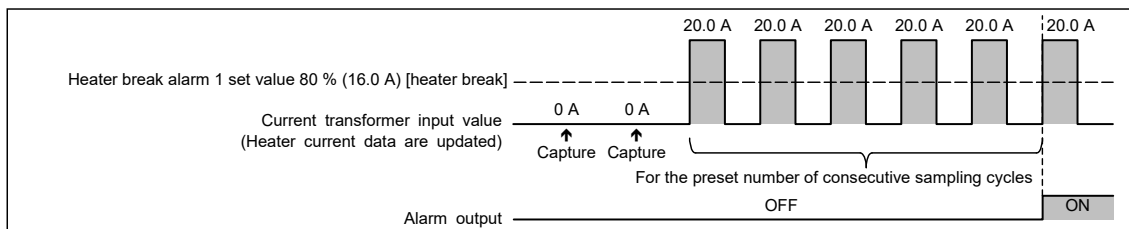

Thyristor break-down



This chart shows the case when Control output is 50 %.

■ How alarm is checked

If the alarm occurs, the relevant error number is shown on the display unit. Therefore in this case, check the alarm contents.

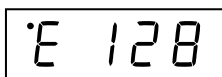

Error display

Error number	Description
128	Heater break alarm 1
256	Thyristor break-down
512	Heater break alarm 2 (heater deterioration)





For the Error display, refer to the **8. ERROR OR ALARM DISPLAY (P. 26)**.

7.10 Current Limiter Function

This is the function of limiting a measured current value to a value not exceeding the preset current limit value. A current value is measured for each constant cycle and then the maximum phase angle not exceeding the Current limit value is computed from the above current value thus measured. If the phase angle at that current output is larger than the maximum phase angle computed, the current is output at the maximum phase angle to restrict that current. The maximum phase angle is computed during a time period of 0.1 seconds from the start of load operation, and the Current limit function is activated after the maximum phase angle is computed.

 **If a load through which large rush current flows is used, the Current limit function cannot restrict the above current. In this case, use the Current limit function together with the Soft-start function.**

 Even at a Soft-start time of 0.0 seconds, the Soft-start function is activated in order to compute the maximum phase angle during a time period of 0.1 seconds from the start of load operation.

 If a current value exceeds “Current limit value + Differential gap (0.5 A or 1 A) **” due to voltage variations or load resistance changes while the Current limit function is being activated, the maximum phase angle is immediately re-computed to restrict it within a cycle of 2.5 from the time when it exceeds “Current limit value + Differential gap.”

* Differential gap 0.5 A: 20 A, 30 A types

Differential gap 1 A: 45 A, 60 A, 80 A and 100 A types

 If a Current limit value is set to its maximum value, the Current limit function is deactivated.

The Current limiter function cannot be used when Zero-cross control is selected.

7.11 Set Data Lock Function

It is possible to prohibit the key operation to prevent an operation error. Validate Set data lock function to lock the UP key. The following parameters are available for Set data lock function.

- Control method (\bar{E})
- Soft-start time (U)
- Soft-down time (d)
- Internal gradient set value (\bar{E})
- Output limiter high (H)
- Output limiter low (L)
- Base-up set value (b)
- Output mode for phase control (σ)
- Internal manual set value (t)
- Contact input action (U)
- Maximum load current set value for alarm (P)
- Heater break alarm 1 set value setting (\bar{q})
- Number of alarm delay times (r)
- Heater break alarm type (\bar{n})
- Alarm output selection (\bar{r})
- Heater break alarm 2 set value setting (F)
- Heater break alarm 2 used/unused (\bar{E})
- Current limit value setting ($\bar{\Xi}$)
- Alarm output state selection (\bar{e})
- Protection function for control of primary side of a transformer (\bar{t})
- Determination set value in case of a break on the secondary side of the transformer (\bar{a})
- Output limiter setting in case of a break on the secondary side of the transformer (h)
- Soft-start time in case of break on the secondary side of the transformer (u)

 For the setting method, refer to **6.2.3 Setting method of Set data lock (P. 12)**.

7.12 Protection Function for Control of Primary Side of a Transformer

If momentary power failure occurs during execution of the control of primary side of a transformer, inrush current is generated. Protection function for control of primary side of a transformer is to protect the thyristor from the inrush current. With this protection function enabled, when momentary power failure occurs, the instrument determines that the secondary side of a transformer was disconnected and suppresses the output. When the instrument is automatically reset from the breakdown (momentary power failure), the soft-start function suppresses the inrush current. To use this protection, the following parameters need to be set.

- Protection function for control of primary side of a transformer (t)
- Determination set value in case of a break on the secondary side of the transformer (a)
- Output limiter setting in case of a break on the secondary side of the transformer (h)
- Soft-start time in case of break on the secondary side of the transformer (u)

☞ For the setting range of parameter, refer to page 16.

☞ For the setting procedure, refer to page 13.

■ Operation chart

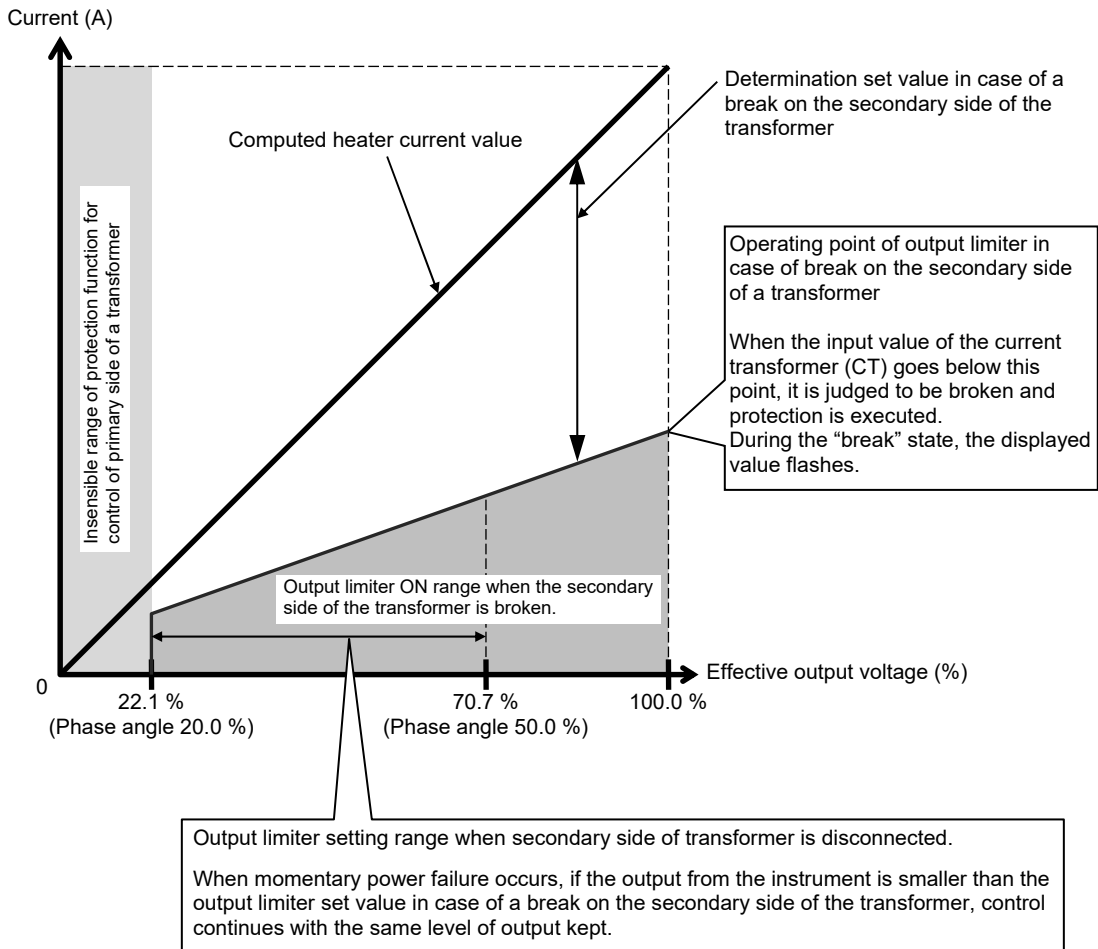

■ Determination of break and release of secondary side of transformer

• Determination of break

While control of primary side of a transformer is executed, if the current transformer (CT) value goes below the determination set value in case of a break on the secondary side of the transformer, it is judged to be a break (momentary power failure). Below is a formula to convert the determination set value in case of a break on the secondary side of the transformer (a) into the current value (A).

$$\text{Current value [A]} = \text{Maximum load current set value [A]} \times \text{Effective output voltage [\%]} \times (100 \% - \text{Determination set value in case of a break on the secondary side of the transformer [\%]})$$

• Determination of release

While the phase angle is 20 % or more, when the current goes over the determination set value in case of a break on the secondary side of the transformer by 0.3 A (instrument of 45 A or more: 1 A), it is judged to be a release from a break (momentary power failure).

■ Display in case of break of secondary side of a transformer

When the signal level goes below the determination set value in case of a break on the secondary side of the transformer, the displayed value flashes. (Parameters of input signal monitor 1 and phase angle ratio monitor flash)
 When the instrument is automatically released from the break (momentary power failure), the display stops flashing and remains lit.

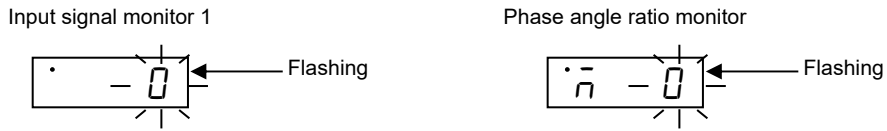

■ Output limiter setting in case of a break on the secondary side of the transformer

This is a function to limit the phase angle between 20.0 % and 50.0 % when the signal goes below the determination set value in case of a break on the secondary side of the transformer.

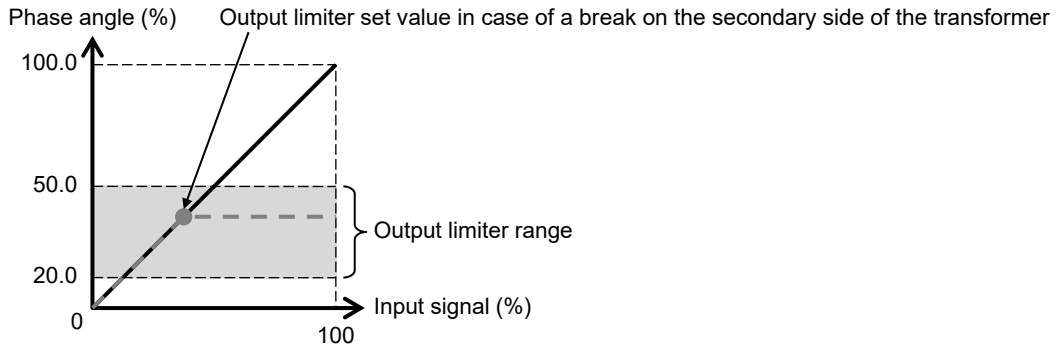

■ Soft-start function in case of break on the secondary side of the transformer

This is a soft-start function which is activated when the instrument is automatically released from the break (momentary power failure) of the secondary side of the transformer.
 This function suppresses the inrush current at the time of automatic release from the break (momentary power failure).

- While the soft-start function of the soft-start time (U) is working, if break (momentary power failure) of secondary side of a transformer occurs, protection function for control of primary side of a transformer starts working to suppress the output.
 When released from the break (momentary power failure), the instrument changes the output according to the soft-start time in case of break on the secondary side of the transformer (u).
 After elapse of the soft-start time in case of break on the secondary side of the transformer (u), the soft-start time (U) takes over, and output is changed in the remaining time of the soft-start time (U).

8. ERROR OR ALARM DISPLAYS

When the error or alarm occurs, the display changes to the Error display. When two or more errors occur simultaneously, the error code numbers are totaled and displayed as one number.

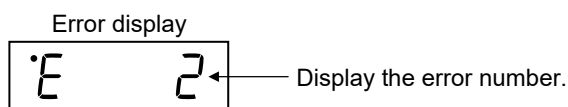

When the power frequency error is displayed, the display can be changed only to the power supply frequency monitor.

When any of the errors show below occurs, other displays will not be displayed.

- Board error
- Data error 1
- Data error 2
- EEPROM error
- Calibration data error

Error display

Error number	Description	Action	Solution
1 (1)	Board error	Thyristor output OFF	Turn off the power at once. If an error occurs after the power is turned on again, please contact RKC sales office or the agent.
2 (2)	Data error 1		
4 (4)	Data error 2		
8 (8)	EEPROM error		
16 (16)	Power frequency error 1*	Thyristor output OFF The output can be turned ON when the error is canceled.	Check the stability of power supply frequency, and turn off the power at once. If an error occurs after the power is turned on again, please contact RKC sales office or the agent.
32 (32)	Power frequency error 2*	Thyristor output OFF	Check the value of power supply frequency, and turn off the power at once. If an error occurs after the power is turned on again, please contact RKC sales office or the agent.
64 (64)	Calibration data error	Thyristor output OFF	Turn off the power at once. If an error occurs after the power is turned on again, please contact RKC sales office or the agent.

*For details of the error, refer to **7.8 Automatic Power Frequency Detection and Power Frequency Monitoring Function (P. 19)**.

Alarm display

Error number	Description	Action	Solution
128 (128)	Heater break alarm 1	Control is continued.	Turn off the power, and check or replace the heater, etc.
256 (256)	Thyristor break-down		If a load generating large rush current is used, thyristor break-down may occur when no Soft-start time is appropriately set. In such a case, make the Soft-start time longer. For any causes other than the above, turn the power off and then contact to your nearest RKC sales agent or our sales office.
512 (512)	Heater break alarm 2 (heater deterioration)		Turn off the power, and check or replace the heater, etc.

9. SPECIFICATIONS

Number of phase:	Single-phase
Rated current:	20 A AC, 30 A AC, 45 A AC, 60 A AC, 80 A AC and 100 A AC For the ambient temperature characteristic, refer to temperature characteristic graph. (P. 3)
Minimum load current:	0.6 A (20 A type), 1 A (30 A, 45 A, 60 A, 80 A and 100 A types)
Power supply voltage:	90 to 264 V AC [Including power supply voltage variation] (Rating: 100 to 240 V AC)
Power frequency:	50/60 Hz (Automatic discriminating)
Allowable power frequency variations:	± 1 Hz (Performance guarantee) ± 2 Hz (Operation guarantee)
Input signal:	Current input 4 to 20 mA DC (Input impedance: 100 Ω) Voltage input 0 to 10 V DC (Input impedance: 68 k Ω) Voltage input 1 to 5 V DC (Input impedance: 30 k Ω) Voltage pulse input 0/12 V DC (Input impedance: 30 k Ω) Dry contact input (Input impedance: 47 k Ω)
Output voltage range:	0 to 98 % of rating voltage
Applicable load:	Phase control: Linearity (R: resistor) load Control of primary side of a transformer The magnetic flux density must be 1.25 T [12,500 Gauss] or less when the protection function for control of primary side of a transformer is not provided. Zero-cross control: Linearity (R: resistor) load
Corresponding utilization category:	AC-51
Overload current profile and duty cycle or OFF-time:	1.1 x I _e – 60 s
Comprising the rating index:	50 - 60
Control method:	Phase control (No feedback) Zero-cross control (No feedback)
Output setting range:	Internal manual set value: 0.0 to 99.9 % (Set by the THV-1 front keys) External manual set value: 0 to 100 % (Set by the setter 1) External gradient set value: 0 to 100 % (Set by the setter 1) Internal gradient set value: 0 to 100 % (0.00 to 1.00) (Set by the THV-1 front keys) Output limiter high set value: 0.0 to 99.9 % (Set by the THV-1 front keys) Output limiter low set value: 0.0 to 99.9 % (Set by the THV-1 front keys) Base-up set value: 0.0 to 99.9 % (Set by the THV-1 front keys) ¹Optional
Output mode:	Proportional phase angle to input ² Proportional voltage to input ² Proportional square voltage (electric power) to input ² Constant current control (optional) ² ² When the Phase control use the linearity (R: resistor) load
Power off leakage current:	27 mA AC rms or less (load voltage 200 V rms, 60 Hz, T _a =25 °C)
Ramp (Soft-start/Soft-down) function:	Setting range: 0.0 to 99.9 seconds (Set by the THV-1 front keys)
Auto/Manual mode selection:	External dry contact External contact closed: Manual mode External contact open: Auto mode
Heater break alarm function (optional):	When the power source ripples of main circuit is sine-wave Input: Current transformer (built-in) Measured accuracy: Within ± 2 A (20 A and 30 A types) Within ± 10 % of maximum load current (45 A, 60 A, 80 A and 100 A types) Output: 1 point, open collector output 24 V DC, Max. 100 mA Output ON/OFF at alarm is selectable.
Protection function for control of primary side of a transformer:	Applicable control method: Phase control Setting range: Protection function for control of primary side of a transformer: 0 (disable)/1 (enable) Determination set value in case of a break on the secondary side of the transformer: 0 to 100 % of computed heater current value (Deviation setting against the computed heater current value.) Output limiter setting in case of a break on the secondary side of the transformer: 20.0 to 50.0 % of phase angle Soft-start time in case of break on the secondary side of the transformer: 0.1 to 99.9 seconds Abnormality judgment conditions: Phase angle 20 % or more Sampling cycle: 0.5 of power cycle Action at the time of automatic release from the break (momentary power failure) of secondary side of the transformer: Output by soft-start function at the time of the break (momentary power failure) of secondary side of transformer.

Current limiter function (optional):

Setting range

20 A, 30 A: 0.0 to 32.0 A

45 A: 0 to 55 A

60 A: 0 to 70 A

80 A: 0 to 90 A

100 A: 0 to 110 A

If a current limit value is set to its maximum value, the current limit function is deactivated.

Ambient temperature: 0 to 40 °C (Performance guarantee range)

-15 to +55 °C (Operation guarantee range)

Ambient humidity: 5 to 95 %RH (Non-condensing)**Power consumption:** 6 VA max.**Withstand voltage:** Between main circuit, power terminals and radiation fins: 1 minute at 2000 V AC**Insulation resistance:** Between main circuit, power terminals and radiation fins: 20 MΩ or more at 500 V DC**Rated conditional short-circuit current:**

1500 A

• 20 A fast-blow fuse for 1 circuit type: Breaking capacity 100 kA

• 20 A fast-blow fuse for 3 circuits type: Breaking capacity 100 kA

• 30 A fast-blow fuse for 1 circuit type: Breaking capacity 100 kA

• 30 A fast-blow fuse for 3 circuits type: Breaking capacity 100 kA

• 45 A fast-blow fuse for 1 circuit type: Breaking capacity 100 kA

• 60 A fast-blow fuse for 1 circuit type: Breaking capacity 100 kA

• 80 A fast-blow fuse for 1 circuit type: Breaking capacity 100 kA

• 100 A fast-blow fuse for 1 circuit type: Breaking capacity 100 kA

Cooling method: Natural convection**Mounting method:** Vertical mounting**Dimensions:** Refer to **4.2 Dimensions (P. 4)**.**Weight:** Approx. 0.9 kg (20 A and 30 A types)

Approx. 1.4 kg (45 A and 60 A types)

Approx. 1.9 kg (80 A and 100 A types)

Standard: Safety standards: UL: UL508 (file No. E177758)

cUL: C22.2 No.14 (file No. E177758)

CE marking: THV-1 conforms to CE marking by using the noise filter. (Refer to P. 6)

LVD: EN 60947-4-3 (Form 4)

EMC: EN 60947-4-3 (Form 4)

EMC test standards: Emissions

The EMC emissions test standards required by the standard EN 60947-4-3 'Contactors and motor-starters - AC semiconductor motor controllers and contactors for non-motor loads' are presented in table 1.

Table 1: EMC emissions standards compliance

Emission type	Test standard
Conducted disturbance	CISPR 11 Environment A Group 2
Radiated EM field	CISPR 11 Environment A

Immunity

The EMC immunity test standards required by the standard EN 60947-4-3 'Contactors and motor-starters - AC semiconductor motor controllers and contactors for non-motor loads' are presented in table 2.

Table 2: EMC immunity standards compliance

Test type	Test standard	Test level
Electrostatic discharge	EN 61000-4-2	Contact: 4 kV Air: 8 kV
Radiated, radio frequency electromagnetic field	EN 61000-4-3	Enclosure port: 80 - 1000 MHz: 10 V/m 1.4 GHz - 2 GHz: 3 V/m 2 GHz - 2.7 GHz: 1 V/m
Electrical fast transient/burst	EN 61000-4-4	AC Power port: 2 kV Signal port: 1 kV
Surge	EN 61000-4-5	AC Power port: 1 kV (line to line)
Conducted disturbances induced by radio frequency fields	EN 61000-4-6	AC Power port Signal port: 0.15 - 80 MHz: 10 V
Voltage dips	EN 61000-4-11	AC Power port: 0 % during 0.5 cycle * 0 % during 1 cycle * 40 % during 10/12 cycles * 70 % during 25/30 cycles * 80 % during 250/300 cycles * * Rated operational voltage
Voltage interruptions	EN 61000-4-11	AC Power port: 0 % during 250/300 cycles (Rated operational voltage)

10. ACCESSORIES (OPTIONAL)

■ Setter (Potentiometer, Knob and Scale plate)

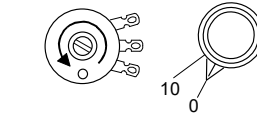
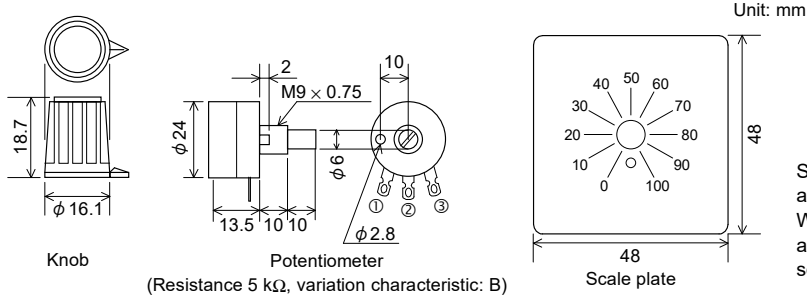

Set the potentiometer full counterclockwise and combine with a scale plate. When setting the knob on the scale plate, align the arrow on the knob with 0 on the scale plate.

■ Output voltmeter (150 V span or 300 V span)

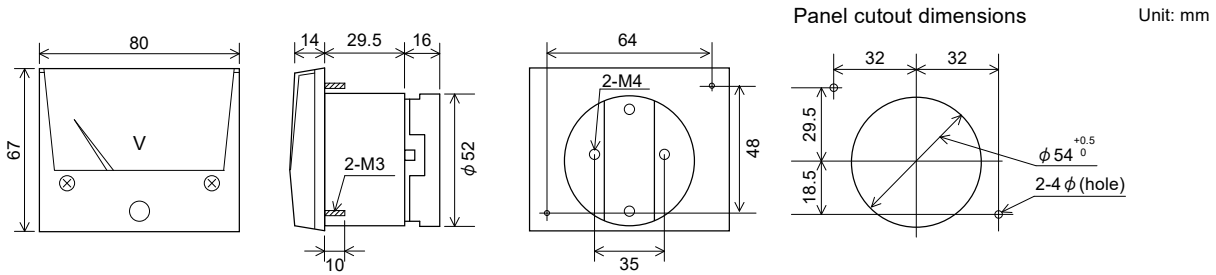

■ Fuse unit (Holder: 3 circuits type)

For 20 A and 30 A

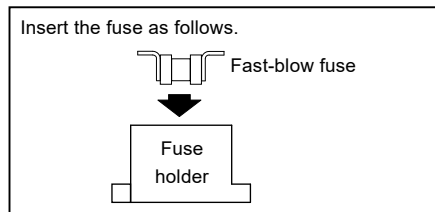
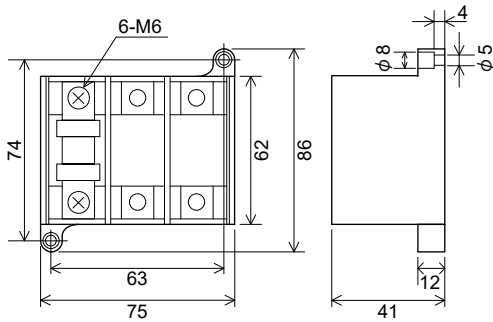

Rated current of fast-blow fuse

Details	Rating
Fast-blow fuse for 20 A	20 A
Fast-blow fuse for 30 A	30 A

■ Fuse unit (Holder: 1 circuit type)

For 20 A, 30 A and 45 A

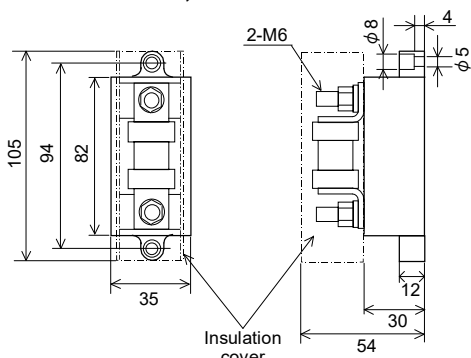

For 60 A, 80 A and 100 A

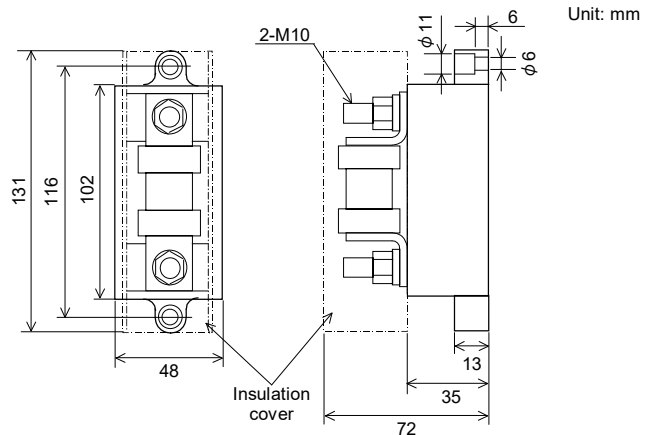

Rated current of fast-blow fuse

Details	Rating
Fast-blow fuse for 20 A	20 A
Fast-blow fuse for 30 A	30 A
Fast-blow fuse for 45 A	50 A

Details	Rating
Fast-blow fuse for 60 A	75 A
Fast-blow fuse for 80 A	100 A
Fast-blow fuse for 100 A	100 A

■ Fuse holder (UL approved instrument) for 20 A and 30 A (1 circuit type) THVP-H04

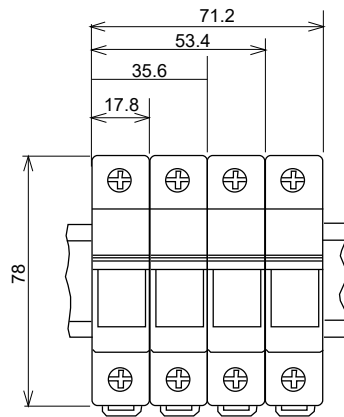
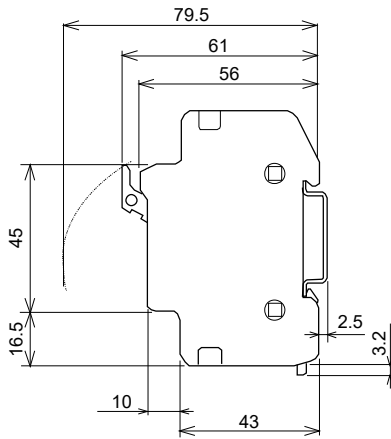

Unit: mm

Rated current of fast-blow fuse
(UL approved instrument)

Details	Rating
Fast-blow fuse (UL approved instrument) for 20 A	20 A
Fast-blow fuse (UL approved instrument) for 30 A	32 A

■ Fuse holder (UL approved instrument) for 45A, 60 A, 80 A and 100 A (1 circuit type) THVP-H05

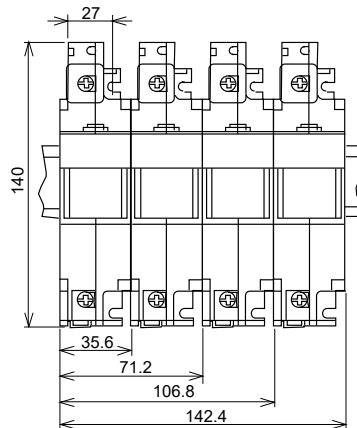
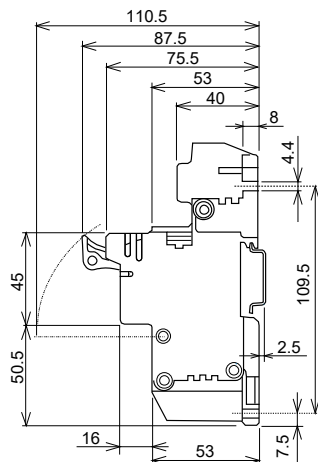

Unit: mm

Rated current of fast-blow fuse
(UL approved instrument)

Details	Rating
Fast-blow fuse (UL approved instrument) for 45 A	50 A
Fast-blow fuse (UL approved instrument) for 60 A	63 A
Fast-blow fuse (UL approved instrument) for 80 A	80 A
Fast-blow fuse (UL approved instrument) for 100 A	100 A

Replacement method of the fuse

- ① Open a front lid. Take fuse out of the holder.

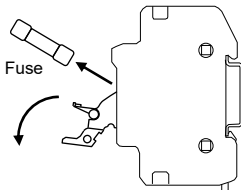

- ② Insert the new fuse.

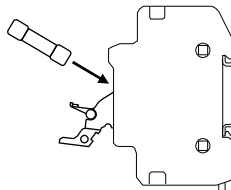

- ③ Close a front lid to finish the work.

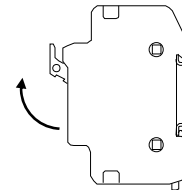

Wiring method of fuse holder

- ① Loosen a screw of holder front.

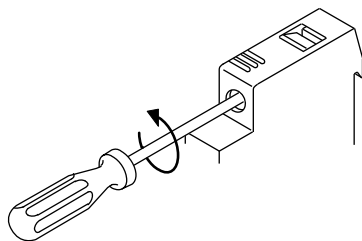

- ② Confirm the location and insert a leadwire.

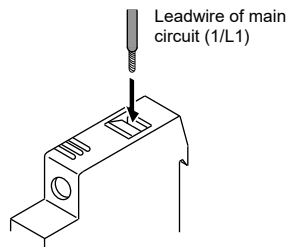

- ③ Tighten a screw of holder front. Wire the leader to the bottom side in the same way as in 1, 2 and 3.

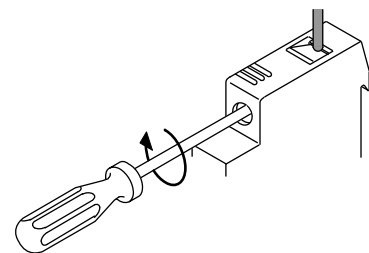

The Figure shows the type of 20 A and 30 A. However, the replacing procedure or wiring procedure is the same as for the type of 45 A to 100 A.

The first edition: JUN. 2002 [IMQ00]
The sixteenth edition: JUL. 2020 [IMQ00]

