



Resin Pressure Sensor

CZ-200P

Instruction Manual

IM100CZ08-E11

Thank you for purchasing this RKC product. In order to achieve maximum performance and ensure proper operation of the instrument, carefully read all the instructions in this manual. Please place the manual in a convenient location for easy reference.

CONTENTS

1. OUTLINE	1
2. PRODUCT CHECK	2
3. HANDLING OF THE PRESSURE SENSOR	2
3.1 Caution in Mounting Pressure Sensors	2
3.2 Caution in Removing Pressure Sensors	4
3.3 Cautions during Extruder Cooling Down	4
3.4 Caution in Handling of Temperature Sensor	4
3.5 Dimensions	4
3.6 Pressure Sensor Installation	5
4. WIRING	5
4.1 Wiring Precaution	5
4.2 Wiring Method	6
5. ADJUSTMENT	7
6. CORRECTION	8
6.1 Correcting Indication Error due to the Operating Temperature	8
6.2 Correcting Indication Error due to the Pressure Sensor Cable Length	8
6.3 Correcting Indication Error when a Cable from Another Company is Used	8
6.4 Correcting Indication Error due to the Safety Barrier	8
7. TROUBLESHOOTING	9
8. SPECIFICATIONS	9
9. EXPLANATION OF EACH TERMS	10

SYMBOLS

WARNING : This mark indicates precautions that must be taken if there is danger of electric shock, fire, etc., which could result in loss of life or injury.

CAUTION : This mark indicates that if these precautions and operating procedures are not taken, damage to the instrument may result.



: This mark indicates that all precautions should be taken for safe usage.



: This mark indicates important information on installation, handling and operating procedures.



: This mark indicates supplemental information on installation, handling and operating procedures.



: This mark indicates where additional information may be located.



WARNING

- To prevent injury to persons, damage to instrument and the equipment, a suitable external protection device shall be required.
- All wiring must be completed before power is turned on to prevent electric shock, fire or damage to the instrument and the equipment.
- This instrument must be used in accordance with the specifications to prevent fire or damage to the instrument and the equipment.
- This instrument is not intended for use in locations subject to flammable or explosive gases. (However, excluding the Explosionproof specification.)
- Do not touch high-voltage connections such as power supply terminals, etc. to avoid electric shock.
- RKC is not responsible if this instrument is repaired, modified or disassembled by other than factory-approved personnel. Malfunction may occur and warranty is void under these conditions.

CAUTION

- This product is intended for use with industrial machines, test and measuring equipment. (It is not designed for use with medical equipment and nuclear energy plant.)

- This is a Class A instrument. In a domestic environment, this instrument may cause radio interference, in which case the user may be required to take additional measures.
- All precautions described in this manual should be taken to avoid damage to the instrument or equipment.
- All wiring must be in accordance with local codes and regulations.
- Tighten each terminal screw to the specified torque found in the manual to avoid electric shock, fire or malfunction.
- Remove resin adhered to the instrument with dry cloth before the resin hardens. Take caution to avoid being burned.
- Tools such as wire wheels or abrasive cloths should never be used to clean the process diaphragm.
- Dropping the instrument may cause the sensor to break or malfunction.
- To protect built-in precision components from damage, handle and install carefully. Take care to avoid damage to the diaphragm.
- Do not wipe or rub the nameplate on the outer case of the resin pressure sensor with a cloth moistened with an organic solvent, or a glove. If so, the printed section may be erased.
- This product uses stainless steel, aluminum, and fluororesin (O-rings and leadwire covering materials). When disposing of each part used for this product, always follows the procedure for disposing of industrial wastes stipulated by the respective local community.
- If the output from the resin pressure sensor is found to be abnormal during the operation, immediately stop the operation and inspect for any distortion or damage of the diaphragm. If the diaphragm is damaged, the pressure of the measured media (e.g.resin) is applied to the inside of the resin pressure sensor. Continued use under such conditions may result in the damage of the screw which fixes the folder in the housing, and the folder in the housing may come off in the worst case.
- Do not use the pressure sensor in stead of a blind bolt.

NOTICE

- This manual assumes that the reader has a fundamental knowledge of the principles of electricity, process control, computer technology and communications.
- The figures, diagrams and numeric values used in this manual are only for purpose of illustration.
- RKC is not responsible for any damage or injury that is caused as a result of using this instrument, instrument failure or indirect damage.
- RKC is not responsible for any damage and/or injury resulting from the use of instruments made by imitating this instrument.
- Periodic maintenance is required for safe and proper operation of this instrument. Some components have a limited service life, or characteristics that change over time.
- Every effort has been made to ensure accuracy of all information contained herein. RKC makes no warranty, expressed or implied, with respect to the accuracy of the information. The information in this manual is subject to change without prior notice.
- No portion of this document may be reprinted, modified, copied, transmitted, digitized, stored, processed or retrieved through any mechanical, electronic, optical or other means without prior written approval from RKC.

1. OUTLINE

■ Main features

- As its lead pipe and pressure sensing blocks have a triple construction output indication changes caused by external transient temperature variations are extremely small. In addition, the attachment of a lead pipe cover (optional) further restricts small output indication changes.
- As the sensor uses the push rod method, resin contamination is prevented for the sensor damage.
- High accuracy of the measured pressure can be achieved when the instrument is used in conjunction with an output converter having linearizing function (PCT-300) or a pressure indicator (PG500). However, excluding the sensor having pressure range (70 MPa or more) and a HASTELLOY C diaphragm.
Accuracy: $\pm 0.5\%$ of span or less

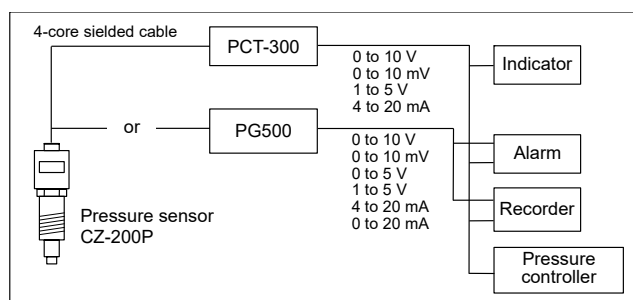

2. PRODUCT CHECK

Before using this product, check each of the following:

- Model code
- Check that all of the items delivered are complete.
- Check that there are no scratches or breakage in external appearance.

■ Resin pressure sensor

CZ - 200P - □□ - □□□ - □□□□ * □□□ - □□□□□
 (1) (2) (3) (4) (5) (6) (7) (8) (9) (10) (11)

(1) Fixing screw type

H: PF3/8 thread	Fixed nut type	Tip ϕ 10
L: PF3/4 thread	Loose nut type	Tip ϕ 18
U: 1/2-20UNF thread *	Fixed nut type	Tip ϕ 7.8
J: PF1/2 thread	Fixed nut type	Tip ϕ 10
V: PF1/4 thread *	Fixed nut type	Tip ϕ 7.8
W: M14 \times 1.5 thread *	Fixed nut type	Tip ϕ 8

* Thread types 1/2-20UNF, PF1/4, and M14 \times 1.5 of INCONEL diaphragm specifications are made to special order specifications. Please contact RKC sales office or the agent for details.

(2) Lead-pipe dimensions

A: Lower part of hexagon nut, L = 120 mm
 B: Lower part of hexagon nut, L = 150 mm
 C: Lower part of hexagon nut, L = 180 mm
 D: Lower part of hexagon nut, L = 210 mm

(3) Diaphragm section material

S: SUS630 (Standard) H: HASTELLOY C
 P: SPRON
 (This has a durability for corrosion of equal with the HASTELLOY C)
 C: INCONEL

(4) Diaphragm surface treatment

N: Standard K: CERAMIC Kanigen plate *
 * SPRON diaphragm and INCONEL diaphragm cannot be specified.

(5) Intrinsically safe

N: Standard (For non-explosionproof specification type)
 G: Explosionproof specification type (For indoor use)
 H: Explosionproof specification type (For outdoor use)

(6) Pressure range

□□□□: See the pressure range code table

(7) Linearize function (Using transducer type)

N: Not provided T: PCT-300□-□□
 G: PG500

(8) Lead-pipe cover

N: Not provided C: Provided

(9) Connector specification

N: Standard connector type ¹ P: Waterproof connector type ^{1,2}
 Q: Direct cable connection type
 (Water-proof: Equivalent to IP67, Cable length: Standard 3 m) ^{3,4}

- Not available for SPRON and INCONEL diaphragm specifications.
- Not available for built-in sensor type
- For SPRON and INCONEL diaphragm specifications, the cable is a flexible tube covered cable (standard length: 0.5 m).
- If the sensor is not the SPRON and the INCONEL diaphragm specifications, it is not supplied with a flexible tube covered cable. It is supplied with a silicon covered cable.

(10) Temperature sensor

(Equivalent to IEC 60584-2, Tolerance class 2, 1.0: 1982 b)

N: None
 K: With built-in K type thermocouple
 J: With built-in J type thermocouple

(11) Temperature sensor lead wire length

□□□□: Unit (mm) [Standard 100 mm (Code: 0100)]

Pressure range code table

Pressure range code	Pressure range (Unit: MPa)	Pressure range code	Pressure range (Unit: MPa)
D05P ^{1,2}	0 to 0.5	020P	0 to 20
001P ²	0 to 1	035P	0 to 35
002P ²	0 to 2	050P	0 to 50
003P ²	0 to 3	070P ³	0 to 70
005P ²	0 to 5	100P ³	0 to 100
010P	0 to 10	150P ²	0 to 150

¹ Only the loose nut type (L type) is available. However, this range can be used when combined with the PG500.

² The SPRON, the INCONEL, and the HASTELLOY diaphragm specifications are not available for the range of 5 MPa or less and 150 MPa.

³ The pressure ranges 70 MPa and 100 MPa of INCONEL diaphragm specifications are special order items.

Please contact RKC sales office or the agent for details.

● Accessories

- Instruction Manual [IM100CZ08-E11]
- Copper Packing one piece
 (Included in only the Loose nut type [thickness: t = 2 mm])



If any of the products are missing, damaged, or if your manual is incomplete, please contact RKC sales office or the agent.

■ Temperature sensor cable (Sold separately)

W-BL-KA-DA-005000: K type thermocouple (Cable length: 5 m)
 W-BL-JA-DA-005000: J type thermocouple (Cable length: 5 m)

■ Pressure sensor cable (Sold separately)

W-AB-N□-PA-5000: Standard (For non-intrinsic safety)
 [Cable length: 5 m]
 W-AB-Y□-PB-5000: Intrinsically safety (Hazardous side)
 [Cable length: 5 m]
 W-AB-N□-DA-1000: Non-intrinsic safety (Non-hazardous side)
 [Cable length: 1 m]

□: Cable cover type
 G: Heat-resistant glass coated cable
 V: Vinyl coated cable
 S: Silicon coated cable

■ Blind bolt (Sold separately)

This is a bolt to be used to fill the hole on the machine from which a pressure sensor has been removed. If a blind bolt is necessary, please contact with our sales staff or the nearest distributor.

3. HANDLING OF THE PRESSURE SENSOR

3.1 Caution in Mounting Pressure Sensors

Observe the following when mounting the pressure sensor.

■ Mounting environment

- Ensure that no cooling pipes directly contact the pressure sensor or connector, since the pressure reading accuracy may be affected or the connector may be damaged.
- Do not locate any heat source near the pressure sensor or directly expose it to heat. Otherwise, high-temperature deterioration of the sensor block may occur. If the temperature could rise in the strain gauge block located within the housing, cover possible heat sources with insulation materials.
- Do not use the pressure sensor under any of the following environmental conditions:
 - Where the sensor is exposed directly to cold air, warm air or hot air.
 - Where the sensor is exposed to direct sunlight.
 - Where temperature variations are large.
 - Where the sensor is directly splashed with water or rain, or the humidity is high.
- Do not bring magnetic devices such as magnetic relays, etc. near the pressure indicator. Also, keep power lines from the resin pressure sensor cable.
- If the pressure sensor is used for screen changer operation, it may suffer an impact during screen changer operation, causing sensor troubles. In such a case, carefully consider the position and direction when installing the sensor.

■ Mounting pressure sensors

- When the diaphragm at the end of CZ-200P and its surroundings completely touch with its mounting hole, large indication error may occur. In this case, temperature may exert a large influence especially upon the zero point. Therefore, much attention should be paid when a mounting hole is drilled.

Do not wind sealing tapes, etc. round this section for preventing oil or resin leakage.

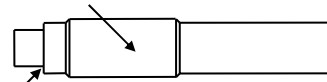

Packing surface (Sealing surface)
[Flat tightening or tapered tightening surface]
(Oil or resin leakage is prevented at this point.)

- When using a lead pipe cover (optional), pay attention that the lead pipe cover end does not directly touch the barrel. (See the ■ **Exposed length at the bottom of the sensor outer case**)

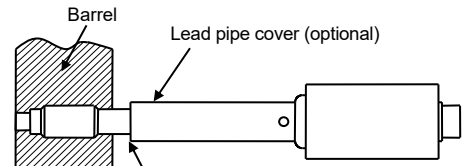

Mount the sensor so that this block does not directly touch the barrel.

- Prior to mounting the pressure sensor, check the appearance of the diaphragm. If the diaphragm has a deformed or abnormal end, it needs to be repaired or re-calibrated. As there is a case where the diaphragm is already deformed when used previously, carefully check its condition before the pressure sensor is re-used.

■ Mounting hole

- When mounting the pressure sensor, check its mounting hole dimensions. (Do not over tighten its screw.)
- If resin or its carbide still remains in the mounting hole, this may damage the pressure sensor. Therefore, prior to mounting the sensor, always remove any residue from the mounting hole.
- Check that the diaphragm surface does not protrude from the inner wall of the barrel, since this may score the diaphragm surface with the screw, etc. If necessary, adjust the position between the diaphragm surface and the inner wall of the barrel using stainless steel packings, etc.
- For the loose nut type, resin leakage may occur more easily than the fixed nut type, as the pressure sealing surface becomes wider. If any resin leaks through the mounting gap of the sensor, use copper packings (thickness: $t = 2 \text{ mm}$ or 1 mm) or aluminum packings (thickness: $t = 2 \text{ mm}$ or 1 mm) by taking into account the position between the diaphragm surface and the inner wall of the barrel.
[Copper Packing (thickness: $t = 2 \text{ mm}$, one piece): Included as standard only on the Loose nut type]

■ Mounting direction

- If the sensor is installed in the upright direction (Fig.1-A), it may be affected directly by heat flow from heater or heat source (rising air current of heated air). In such a case, the temperature of the strain gauge in the sensor may exceed an allowable maximum temperature of $200 \text{ }^\circ\text{C}$. In order not to exceed this limit temperature, it is necessary to keep the sensor outer cylinder surface at a temperature of less than $180 \text{ }^\circ\text{C}$ (Fig.2). Conduct the following measures.
 - In order to avoid heat flow, wind a heat insulating material round such a heat source (heater, etc.).
 - Further extend the length of the exposed lead pipe.
- In order to keep the specified sensor performance longer, it is recommended that the sensor outer cylinder surface temperature be kept at less than $180 \text{ }^\circ\text{C}$.
- When the sensor is installed in the upright position, thermal effects on the sensor may not sufficiently lessen even if the length of the exposed lead pipe is further extended. In this case, take measures of 1.
- The effect of heat flow lessens as the installing direction of the sensor changes from the slanting direction (Fig.1-B) to the horizontal direction (Fig.1-C) in this order. In this case, take measures of 1 and 2 if necessary by checking the sensor outer cylinder surface temperature.
(To the relevant manufacturer: It is recommended that the sensor be installed in the horizontal or slanting direction in order to lessen the effect of heat on the strain gauge.)

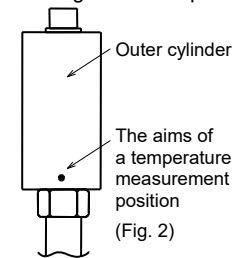
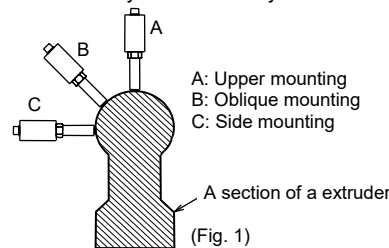

■ Exposed length at the bottom of the sensor outer case

- Cases where the temperature of the strain gauge in the sensor become less than $150 \text{ }^\circ\text{C}$ is as follows:
 - The effect of heat flow is small.
 - The sensor is installed in the upright position.
 - The diaphragm is at a temperature of $400 \text{ }^\circ\text{C}$.
 - The length of the exposed sensor outer cylinder is more than 70 mm .
 (See Figure at the right)

However, as the effect of heat flow from an actual extruder is serious, if there is no enough exposed section below the sensor outer cylinder even at a diaphragm temperature of less than $200 \text{ }^\circ\text{C}$, the operating temperature of the sensor strain gauge may exceed its limit. Therefore, check the temperature environment where the sensor is installed (by indirectly checking the temperature of the sensor outer cylinder surface), and take necessary measures to lessen the temperature of the sensor strain gauge by using a heat insulating material, if necessary.



If the temperature of the sensor outer cylinder surface exceeds $160 \text{ }^\circ\text{C}$, the outer cylinder surface changes its color from black to dark brown and then brown in this order. If it exceeds $180 \text{ }^\circ\text{C}$, the color may change to silver.

- A lead pipe cover (optional) is mainly for protecting the exposed section below the sensor outer cylinder from being exposed to cold wind. Therefore, do not install the sensor such that it is embedded in the heat source (such as in the barrel or heater) together with the lead pipe cover. This may heighten thermal conductivity from the heat source, resulting in a temperature increase in the sensor strain gauge.

■ Handling of cable

Do not bend the flexible tube covered cable and the flexible tube for thermocouple protection at a radius less than the bending radius. Do not forcibly pull or twist them. It may cause a disconnection of the internal conductors, and a damage to the cables.

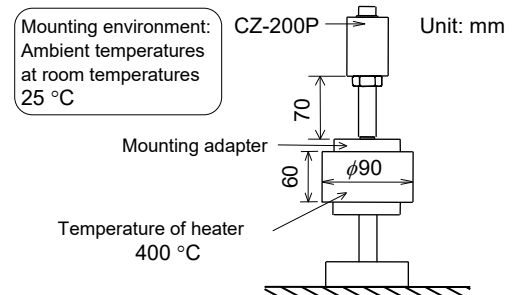

3.2 Caution in Removing Pressure Sensors

- Always remove the sensor while resin is being melted, since the diaphragm of the sensor may be damaged if the sensor is removed after the resin has hardened. If the sensor is re-mounted under this condition the repeatability may deteriorate.
- When removing the pressure sensor, remove it under the same temperature as that during installation. Removing the pressure sensor under the different temperature as that during installation cause irregular engagement of the thread.
- If resin flows into the gap between the lead pipe and the mounting hole, it may be impossible to remove the sensor even with the threads completely disengaged. In this case, if the sensor is forcibly removed using a puller, the sensor may be knocked when removed, damaging the diaphragm and reducing the accuracy. Slowly remove the sensor without knocking it.
- Remove the resin attached to the pressure sensing part (diaphragm and its surrounding section) after melting it by applying light heat to the side of the pressure sensing part using a burner (Do not let the temperature exceed 400 °C). In addition, care should be taken not to scratch the pressure sensing block. If not, diaphragm damage or resin leakage may result.
- Do not hold or carry the pressure sensor by the thermocouple protecting flexible tube or the plug.
- Do not bend the flexible tube covered cable and the flexible tube for thermocouple protection at a radius less than the bending radius. Do not forcibly pull or twist them. It may cause a disconnection of the internal conductors, and a damage to the cables.

3.3 Cautions during Extruder Cooling Down

If the temperature is decreased while resin remains in the extruder with the pressure sensor installed, the diaphragm may be depressed and deformed by resin contraction, etc. As a result, a measurement error or pressure dead-band may occur. If the extruder is cooled down, completely remove all the resin remaining in the barrel, or remove the sensor. Especially take care for the low pressure sensor, as this effect becomes serious.

3.4 Caution in Handling of Temperature Sensor

- Do not stretch, twist, crush or bend the thermocouple protecting flexible tube extended from the outer cylinder or the thermocouple plug. If so, the thermocouple may be damaged to disable temperature measurement or a temperature error may result.
- The temperature sensing block is located about 2 mm within the diaphragm and as a result, the measured temperature usually becomes lower than the actual temperature depending on the melted resin now being heat-generated within the barrel or dice.

 A class 2 thermocouple (classification of tolerance: Equivalent to IEC 60584-2, Tolerance class 2, 1.0: 1982 b) is used when an optional temperature sensor is specified.

3.5 Dimensions

■ Fixed nut type (CZ-200P-H type)

External dimensions

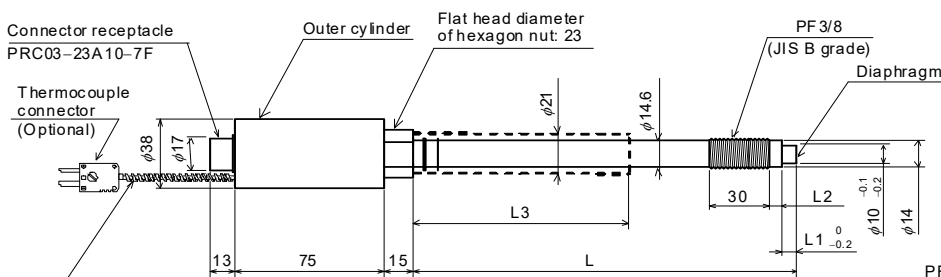

	L	L1	L2	L3	Weight
HA	120	8	6	60	Approx. 430 g
HB	150	8	6	90	Approx. 470 g
HC	180	8	6	120	Approx. 510 g
HD	210	8	6	150	Approx. 550 g

Mounting hole dimensions

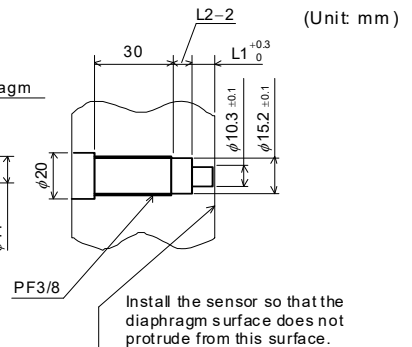

※ Fixing screws of sensor finished to JIS B grade. Install the sensor so that each screw is smoothly inserted.

■ Loose nut type (CZ-200P-L type)

External dimensions

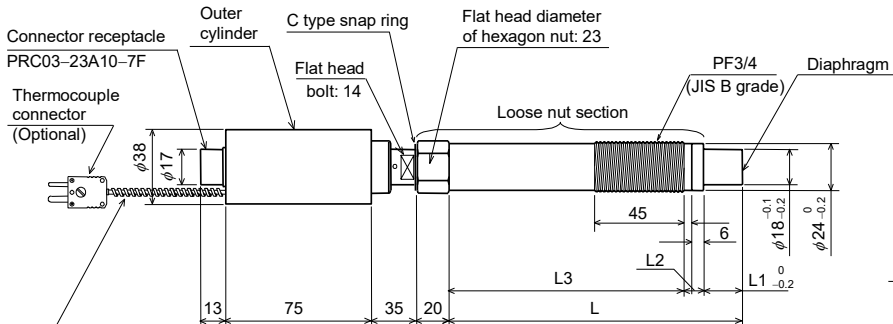

	L	L1	L2	L3	Weight
LA	120	20	10	90	Approx. 760 g
LB	150	20	10	120	Approx. 850 g
LC	180	20	10	150	Approx. 940 g
LD	210	20	10	180	Approx. 1030 g

Mounting hole dimensions

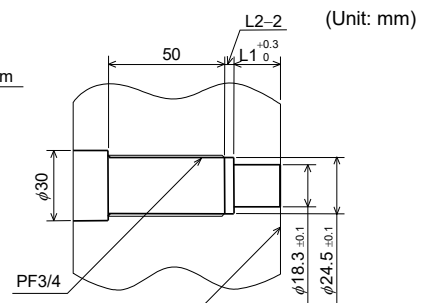

※ Fixing screws of sensor finished to JIS B grade. Install the sensor so that each screw is smoothly inserted.

■ Fixed nut type unified thread (CZ-200P-U type)

External dimensions

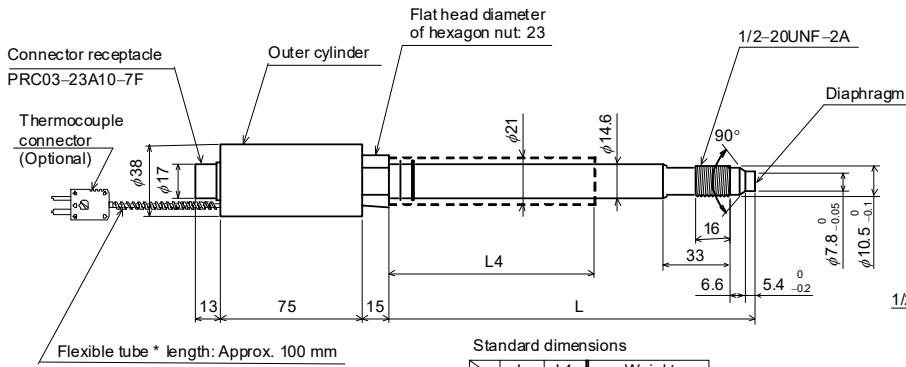

Standard dimensions

	L	L4	Weight
UA	120	60	Approx.410 g
UB	150	90	Approx.450 g
UC	180	120	Approx.490 g
UD	210	150	Approx.530 g

* Bending radius of flexible tube: 19 mm or more

--- Dotted-line section:
Dimensions of lead pipe cover (Optional)

Mounting hole dimensions

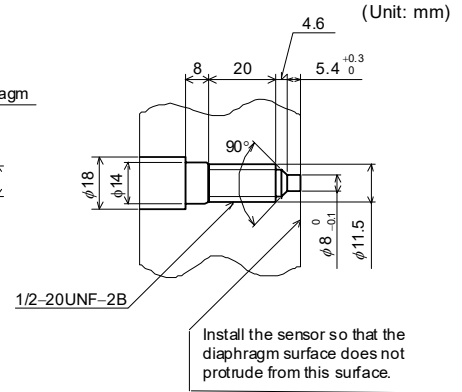

※ Fixing screws of sensor finished to JIS B grade.
Install the sensor so that each screw is smoothly inserted.

■ Fixed nut type with directly connected cable (CZ-200P-H type)

When the diaphragm material is *SPRON* or *INCONEL*, only a fixed nut type with directly connected cable is available.

External dimensions

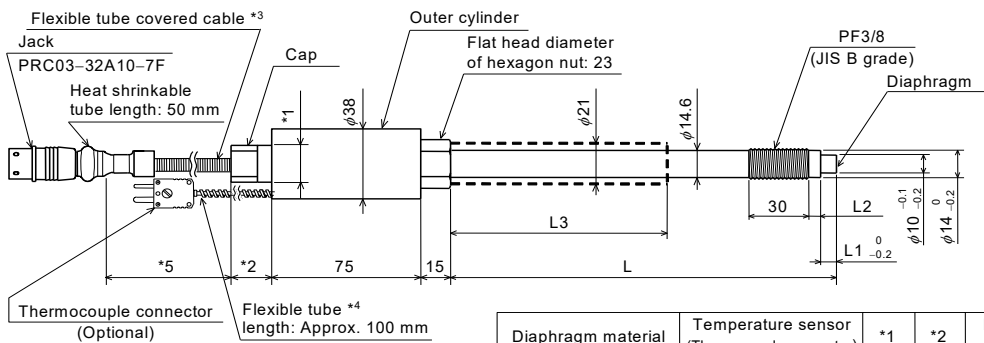

Standard dimensions

	L	L1	L2	L3	Weight
HA	120	8	6	60	Approx. 670 g
HB	150	8	6	90	Approx. 710 g
HC	180	8	6	120	Approx. 750 g
HD	210	8	6	150	Approx. 800 g

Thermocouple connector (Optional)
Flexible tube *4 length: Approx. 100 mm

• The outer tube and the cable section of the loose nut type and the unified thread type with directly connected cable are the same as the above figure.

• The mounting hole dimensions are the same as those for the standard type.

--- Dotted-line section: Dimensions of lead pipe cover (Optional)

Diaphragm material	Temperature sensor (Thermocouple connector)	*1	*2	Flexible tube covered cable	*5 Standard Cable length
SUS630 HASTELLOY C	Not supplied	φ26	15	Not supplied	3000
	Supplied	φ20	12	(silicon covered cable only)	
SPRON INCONEL	Not supplied	φ20	20	Supplied	500
	Supplied				

*3 Bending radius of flexible tube covered cable: 31 mm or more

*4 Bending radius of flexible tube (Thermocouple protecting): 19 mm or more

3.6 Pressure Sensor Installation

1. Make sure the mounting hole is correctly machined. If installing the pressure sensor into a previously used hole, make sure the hole is thoroughly cleaned to remove any plastic residue.
2. Lubricate the threads with a high temperature anti-seize lubricant.
3. Tighten the hexagon nut part with a torque wrench. When tightening the pressure sensor, always tighten only the hexagon nut part.
 - Fixed nut type: 30 N·m
 - Loose nut type: 60 N·m



Tighten the pressure sensor to secure it after the temperature rises.



Do not tighten any block other than the hexagonal nuts, since this may damage the pressure sensor.

4. WIRING

4.1 Wiring Precaution

- If the pressure sensor is used together with the output converter (PCT-300) or pressure indicator (PG500), always connect a shielded wire to the SHD (E) terminal on the equipment side.
- Connect a grounding wire to the extruder.
- For a heat-resistant glass covered cable, the cover is made of fibers. Therefore, the electrical insulation may deteriorate if the cable is exposed to high humidity or conductive liquid (water, etc.) and cause a pressure indication error. For this reason, avoid underground wiring or wiring within electric conduits passing through humid areas as much as possible.
- Do not bend the flexible tube covered cable and the flexible tube for thermocouple protection at a radius less than the bending radius. Do not forcibly pull or twist them. It may cause a disconnection of the internal conductors, and a damage to the cables.

4.2 Wiring Method



Do not place magnet relays or any other equipment which causes magnetic disturbance near the output converter. Route the pressure sensor cable away from the power cables.

■ Wiring example of standard type

- Wiring with PCT-300 (output converter)

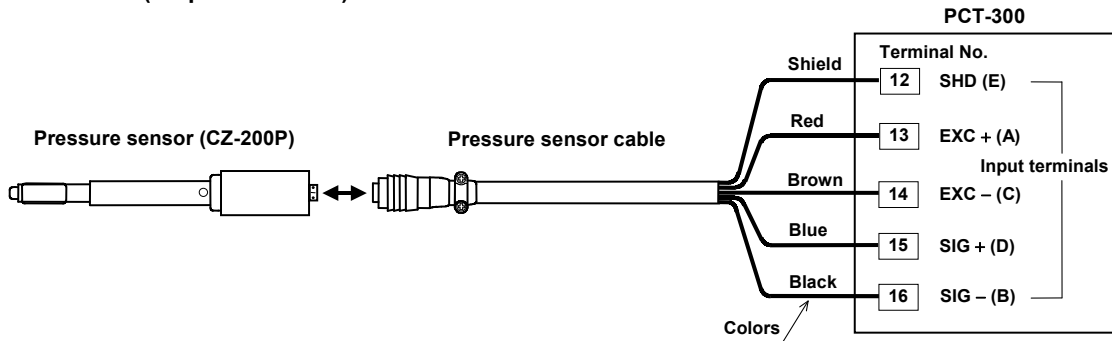

- Wiring with PG500 (pressure indicator)

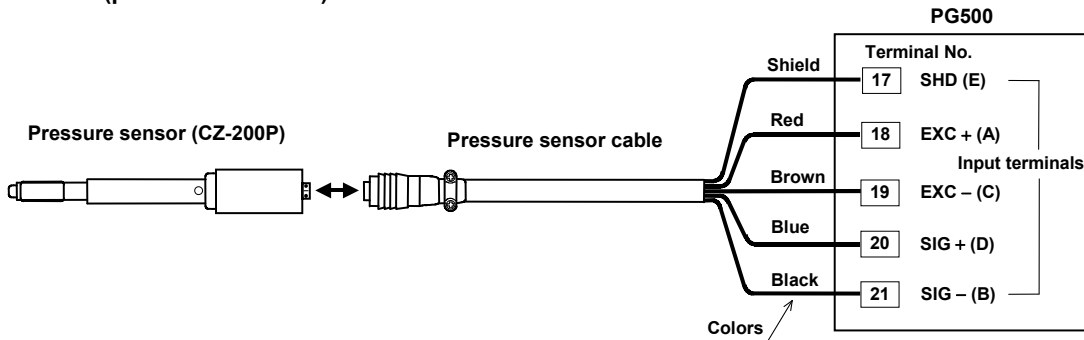

For details on wiring with PCT-300 or PG500, refer to the relevant instruction manual.

■ Wiring example of built-in temperature sensor type (Optional)

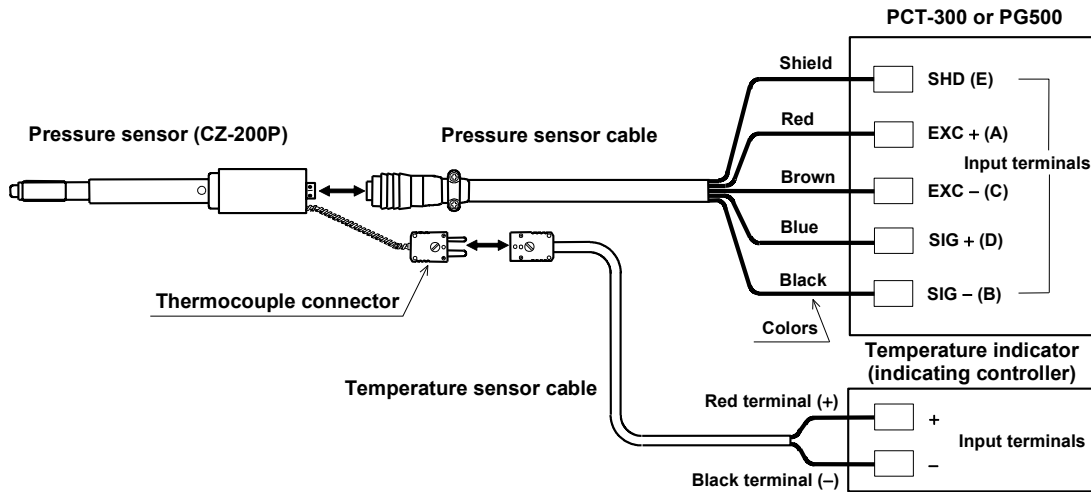

For details on wiring with the temperature indicator (indicating controller), refer to the relevant instruction manual.

■ Wiring example of explosionproof specification

Instrument configuration diagram

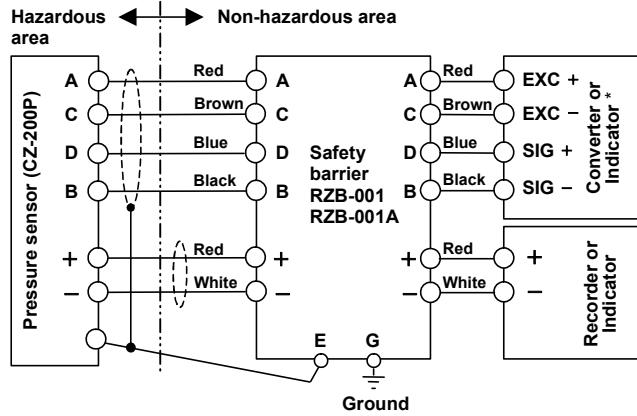

* PCT-300E or PG500

Terminal symbol	Details
A	Power supply circuit (Polarity +, color of lead covering material: red)
C	Power supply circuit (Polarity -, color of lead covering material: brown)
D	Signal circuit (Polarity +, color of lead covering material: blue)
B	Signal circuit (Polarity -, color of lead covering material: black)
+	Thermocouple circuit (Polarity +, color of lead covering material: red)
-	Thermocouple circuit (Polarity -, color of lead covering material: white)
E	Shielded ground terminal

5. ADJUSTMENT

Be sure to perform zero point adjustment. The adjustment method varies depending on the converter (indicator), so refer to the instruction manual of the converter (indicator) connected to the CZ-200P.

Following are the adjustment instructions for when connected to our PCT-300 converter.

■ Adjustment procedure

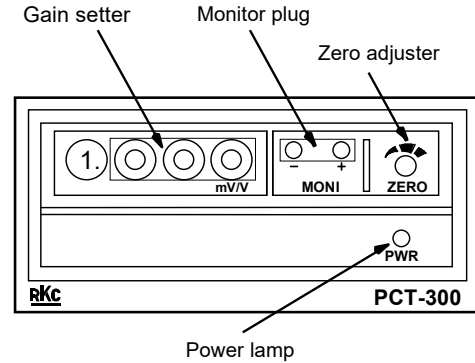

1. Check the rated output (mV/V) described on the nameplate of the CZ-200P (This output should be corrected when the cable is extended.) and then set that value on the rotary switch which is a gain setter of the PCT-300.
2. The pressure reading zero point is adjusted by the zero adjuster in PCT-300. Perform this zero adjustment after the position installed with CZ-200P on the extruder reaches the desired temperature and is in the steady state.

If an indicator is not available, adjust the zero point on the monitoring terminals using a circuit tester. In addition, perform the above adjustment after warming up for 20 minutes or more with the power switch of PCT-300 turned ON (power lamp lights) after wiring has been finished.

- When the gain setter and zero adjuster are set using small screwdriver.
- When the sensor is provided with the gain selection function (optional), the output value is doubled if the function is set to "×2," which is effective for increasing the reading at low-pressure. The valid range is within the output range of PCT-300, which corresponds to half of the sensor range (pressure rating).
- Turn the FILTER switch to the OFF side (100 Hz, -3 dB) when quick response is required. The FILTER switch is turned to the ON side (10 Hz, -3 dB) prior to shipment.

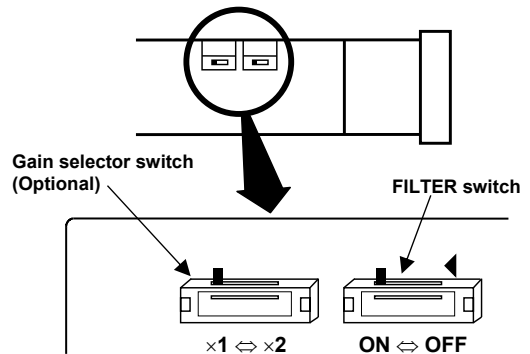

6. CORRECTION

6.1 Correcting Indication Error due to the Operating Temperature

The pressure indication error caused by the difference between the pressure sensor's calibration temperature and the operating temperature can be adjusted using the converter's (PCT-300 and PG500) gain setting. If necessary, correct the pressure indicator error [pressure sensor output (sensitivity) affected by temperature].

■ Correction procedure

1. The rated output after the correction is calculated from the following correction equation and correction factor.

$$e_1 = [1 + \text{Correction factor} \times (T - \text{Calibration temp.})] \times e_0$$

e_0 : Rated output of the resin pressure sensor
 e_1 : Rated output after the correction
 T: Operating temperature
 Correction factor: See below

(The correction factor is the actual value and not the warranted value.)

Correction factor:

Diaphragm material	Calibration temperature (°C)	Correction factor
SUS630	150	+0.13 × 10 ⁻³
SUS630 + Kanigen plate	150	+0.13 × 10 ⁻³
SPRON	250	+0.10 × 10 ⁻³
HASTELLOY C	150	Please contact RKC sale office or the agent.
HASTELLOY C + Kanigen plate	250	
INCONEL	250	

2. Set the value calculated in "1." to the gain setting portion of the converter (PCT-300: Gain setter, PG500: Gain setting parameter).

Example:

When the $e_0 = 1.500$ SUS630 diaphragm material's pressure sensor is used at 230 °C.

$$e_1 = [1 + 0.13 \times 10^{-3} \times (230 - 150)] \times 1.500$$

$$e_1 = 1.516$$

Set 1.516 to the gain setting portion of the converter.

6.2 Correcting Indication Error due to the Pressure Sensor Cable Length

RKC Instrument's resin pressure sensor is calibrated for the standard cable length (5 m). Therefore, if the total length of the pressure sensor cable connected to the intrinsically safe circuit and non-intrinsically safe circuit side is other than 5 meters, the resin pressure sensor indication value can be corrected using the converter's gain setting.

■ Correction procedure

1. The rated output after the correction is calculated from the following correction equation and correction factor.

$$e_1' = e_0' / [1 + K \times (L - 5)]$$

e_0' : Rated output of the resin pressure sensor
 e_1' : Rated output after the correction
 K (Correction factor):
 1.96 × 10⁻⁴/m (Standard specification type)
 1.40 × 10⁻⁴/m (Explosionproof specification type)
 L: Cable total length (m)
 [However, when using RKC Instrument's standard cable.]

2. Set the value calculated in "1." to the gain setting portion of the converter (PCT-300: Gain setter, PG500: Gain setting parameter).

Example:

Cable total length (L) = 10 m
 Rated output of the resin pressure sensor (e_0') = 1.500

$$e_1' = 1.500 / [1 + 1.96 \times 10^{-4} \times (10 - 5)]$$

$$e_1' = 1.499$$

Set 1.499 to the gain setting portion of the converter.

6.3 Correcting Indication Error when a Cable from Another Company is Used

The nominal cross-sectional area of our cable conductor is 0.5 mm². When a cable from another company is used, the resin pressure sensor's indication value can be corrected by correcting the gain setting of the converter (PCT-300 and PG500).

■ Correction procedure

1. The rated output after the correction is calculated from the following correction equation and correction factor.

$$e_1' = e_0' / [1 + 0.5/S \times K \times (L - 5)]$$

e_0' : Rated output of the resin pressure sensor
 e_1' : Rated output after the correction
 S: Conductor nominal cross-sectional area (mm²)
 K (Correction factor):
 1.96 × 10⁻⁴/m (Standard specification type)
 1.40 × 10⁻⁴/m (Explosionproof specification type)
 L: Cable total length (m)

2. Set the value calculated in "1." to the gain setting portion of the converter (PCT-300: Gain setter, PG500: Gain setting parameter).

Example:

Cable total length (L) = 10 m

Conductor nominal cross-sectional area (S) = 0.75 mm²

Rated output of the resin pressure sensor (e_0') = 1.500 mV/V

$$e_1' = 1.500 / [1 + 0.5/0.75 \times 1.96 \times 10^{-4} \times (10 - 5)]$$

$$e_1' = 1.499$$

Set 1.499 to the gain setting portion of the converter.



When explosion-proof specifications are required, use a cable with an allowable capacitance between the cable wires of 0.1 μF or less and an allowable inductance of 0.6 mH or less.



The allowable inductance could be exceeded if the cable is wound, so do not wind the cable when using it.

6.4 Correcting Indication Error due to the Safety Barrier

A pressure indication error caused by the dispersion of our RZB-001 internal resistance value is within about 1 % of span. However, when this error needs to be lessened further, make the correction, if necessary. For this correction, the barrier correction factor B is used. No correction is required when the barrier correction factor B is "1.000."



The barrier correction factor B is described on the nameplate of the RZB-001.

■ Correction procedure

1. The rated output after the correction is calculated from the following correction equation and correction factor.

$$e_1'' = B \times e_0''$$

e_0'' : Rated output of the resin pressure sensor
 e_1'' : Rated output after the correction
 B: Barrier correction factor

2. Set the value calculated in "1." to the gain setting portion of the converter (PCT-300: Gain setter, PG500: Gain setting parameter).

Example:

Barrier correction factor (B) = 1.001

Rated output of the resin pressure sensor (e_0'') = 1.500 mV/V

Rated output after the correction = e_1''

$$e_1'' = 1.001 \times 1.500$$

$$e_1'' = 1.502$$

Set 1.502 to the gain setting portion of the converter.

7. TROUBLESHOOTING

Problem	Possible cause
Indication pointer completely defects to the left or right.	<ul style="list-style-type: none"> Indicator input circuit not connected. Pressure sensor cable not connected. Defective connector used (standard or water resistant connector).
Digital display overflows or underflows.	<ul style="list-style-type: none"> Wires disconnected or shorted. Internal sensor wiring not connected. Insulation deteriorated because Heat-resistant glass fiber covered cable immersed in water or exposed to high humidity. Rated output not set to the PCT-300 (different gain). Double gain selector switch turned ON. Strain gauge deteriorated due to exposure to high temperature. Zero adjuster not adjusted.
No pressure is indicated under pressurized condition.	<ul style="list-style-type: none"> Irregularly tapped hole for installing the CZ-200P. (The sensor tip strongly contacting with the tapped hole.) The diaphragm deteriorated, deformed or damaged.* Mechanical Lead pipe deformation by external force.
Pointer or indication fluctuates during relay actuation.	<ul style="list-style-type: none"> Measures for relay spark killing taken. Improper wiring/grounding of pressure sensor cable. PCT-300 located near magnetic relays.
Pressure indication is fluctuated.	<ul style="list-style-type: none"> Value different from the sensor rated output set to the rated output setter for the PCT-300. The diaphragm deteriorated, deformed or damaged.* The sensor exposed to hot or cold wind. Some potential against the earth generated (Two-point grounding, etc.).
Normal operation was performed, but no reading was received after a while or the reading varied and was unstable.	<ul style="list-style-type: none"> Imperfect connector contact. The lead pipe deformed by external force. The diaphragm deteriorated, deformed or damaged.* Insulation deteriorated because Heat-resistant glass fiber covered cable immersed in water or exposed to high humidity. The sensor exposed to hot or cold wind. The extruders now in unstable operation or temperature rise.
Indication fluctuates from the beginning.	<ul style="list-style-type: none"> The sensor tip forcibly tightened due to the small tapped hole. The lead pipe cover contacting with the barrel, etc.
Resin leakage.	<ul style="list-style-type: none"> Sealed surface deformed or scratched. Foreign material (carbide, etc.) attached on the sealed surface. Low sealed surface accuracy (parallelism, axis, etc.). Screw not threaded down to the extreme end. Tightened at less than appropriate torque or not tightened.
No threads regularly engaged (no screw removed).	<ul style="list-style-type: none"> Screw not threaded down to the extreme end. Not threaded as conforming to the standard. Screw with burrs used. Tightened at excessive torque. Tightened at temperature different from the initial tightening temperature. Screw threads stuck with foreign materials or stained.
Indication of Temperature sensor is lower value.	<ul style="list-style-type: none"> A protecting flexible tube of thermocouple and thermocouple plug are deteriorated, deformed, or damaged.

For taking measures, also see **3. HANDLING OF THE PRESSURE SENSOR** on page 2. The converter is described on a basis of the PCT-300. The operation of the PG500 may differ from that of the PCT-300 described here.

 For the cause of diaphragm deterioration, deformation or damage, see the * **Main causes** on page 9.

* Main causes:

These causes may arise independently or in mutual relations.

• Generative cause in operation

Overpressure	Load pressure exceeding its limit applied.
Irregular thread engagement	The metal pressure sensing surface mechanically scratched or chipped off.
Metal fatigue	The metal sensing surface fatigued by the application of changing or repeating pressure.
Corrosion	The pressure sensing surface corroded due to its contact with corroding material.
Abrasion	The pressure sensing surface worn away due to the mixture of fillers, etc.
Shrinkage	The pressure sensing surface deformed due to the shrinkage of resin adhered to its surface as a result of extruder cooling down.
Separation	The pressure sensing surface deformed or damaged by resin adhered to its surface due to the removal of the sensor while the resin is not yet melted or its melted condition is imperfect.
Protrusion	The pressure sensing surface deformed or damaged due to the protrusion of the push rod from the lead pipe as a result of an external force applied by the screen changer, etc.
Contact	The pressure sensing surface deformed due to the forced contact of the sensor outer side with the hole inner surface as a result of the finish of the hole inner surface.

• Generative cause in mounting and removing

Impact	The pressure sensing surface deformed due to its strong strike with solid material.
Dropping	The pressure sensing surface or its circumference scratched or deformed due to sensor dropping.
Handling	After the resin attached to the sensor tip is heated by a gas burner, etc. for its removal at the time of inspection, the pressure sensing surface scratched with a metal brush, etc.
Excessive tightening	The diaphragm deformed or damaged as the push rod pushes the diaphragm from the inside as a result of the deformation of the sensor flange by excessive tightening torque.

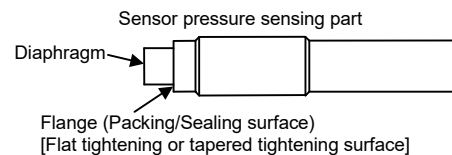

8. SPECIFICATIONS

■ Pressure measurement section

• Specification

Sensing block construction:

4-side adhesion-type strain gauge, Wheatstone bridge

Rated pressure:

Fixed nut type: 10 MPa, 20 MPa, 35MPa, 50 MPa, 70 MPa, 100 MPa, 150 MPa

Loose nut type: 0.5 MPa *, 1 MPa, 2 MPa, 3 MPa, 5 MPa, 10 MPa, 20 MPa, 35MPa, 50 MPa, 70 MPa, 100 MPa

* However, this range can be used when combined with the PCT-300 Double gain or PG500



The SPRON, the INCONEL, and the HASTELLOY diaphragm specifications are not available to the range of 5 MPa or less and 150 MPa. The pressure ranges 70 MPa and 100 MPa of INCONEL diaphragm specifications are special order items. Please contact RKC sales office or the agent for details.

Rated output:

1.000 to 1.800 mV/V

[Calibration temperature: At diaphragm temperature of 150 °C or 250 °C]

0.500 to 0.900 mV/V (For the "0.5 MPa" range)

[Calibration temperature: At diaphragm temperature of 150 °C or 250 °C]



The output of each sensor becomes a specific value within the range of 1.000 to 1.800 mV/V.

Bridge impressed voltage:

10 V DC (When using PCT-300),

7.7 V DC (When using PG500)

Accuracy:

SUS630 diaphragm specification type [At diaphragm temperature of 150 °C]:

The range of 70 MPa or less: ± 1.0 % of span

The range of 100 MPa or more: ± 2.0 % of span

SPRON and INCONEL diaphragm specification types *:

* At diaphragm temperature of 250 °C

± 1.0 % of span

480 °C or more: ± 2.0 % of span

Linearity:Same as **Accuracy****Hysteresis:**

SUS630 diaphragm specification type [At diaphragm temperature of 150 °C]:

The range of 50 MPa or less: ± 0.5 % of spanThe range of 70 MPa or less: ± 1.0 % of spanThe range of 100 MPa or more: ± 2.0 % of span

SPRON and INCONEL diaphragm specification types *:

* At diaphragm temperature of 250 °C

 ± 1.0 % of span480 °C or more: ± 2.0 % of span**Repeatability:**

SUS630 diaphragm specification type [At diaphragm temperature of 150 °C]:

 ± 0.2 % of span

SPRON and INCONEL diaphragm specification types *:

* At diaphragm temperature of 250 °C

 ± 0.2 % of span480 °C or more: ± 0.4 % of span**Zero balance:** ± 0.6 mV/V (± 40 % of span)**Bridge resistance:**Input side: $350 \pm 5 \Omega$, Output side: $350 \pm 5 \Omega$ **• Temperature characteristics****Maximum diaphragm:**

SUS630 and HASTELLO Y C diaphragm specification types: 400 °C

SPRON and INCONEL diaphragm specification types: 550 °C

Maximum strain gauge temperature:

200 °C



When the temperature at the bottom of outer tube (nut side) is more than 180 °C, the temperature at the strain gauge exceeds 200 °C. *

* If the temperature at the strain gauge exceeds 200 °C, the performance cannot be assured. Therefore, cover the heat source with a heat insulating material so that the above temperature does not exceed 200 °C.

The temperature at the strain gauge can be expected not to rise when:

- the long type of sensor is used or
- the sensor is installed aslant or transversely.

If any of the above measures can be taken, take it.

Zero shift due to temperature change:

SUS630 diaphragm specification type [As to diaphragm temperature]:

 ± 0.2 % of span /10 °C, ± 0.3 % of span /10 °C (the range of 10 MPa and 150 MPa), ± 0.4 % of span /10 °C (only the "0.5 MPa" range)

SPRON diaphragm specification type [As to diaphragm temperature]:

 0.1 ± 0.2 % of span /10 °C

INCONEL diaphragm specification type [As to diaphragm temperature]:

 ± 0.3 % of span /10 °C**Output (sensitivity) shift due to temperature change:**

SUS630 diaphragm specification type [As to diaphragm temperature]:

 ± 0.2 % of span /10 °C, ± 0.3 % of span /10 °C (the range of 10 MPa and 150 MPa), ± 0.4 % of span /10 °C (only the "0.5 MPa" range)

SPRON diaphragm specification type [As to diaphragm temperature]:

 0.15 ± 0.2 % of span /10 °C

INCONEL diaphragm specification type [As to diaphragm temperature]:

 ± 0.3 % of span /10 °C**• Mechanical characteristics****Allowable over pressure:**

120 % of span (0.5 MPa: 1000 % of span, 1 MPa: 500 % of span)

Limited over pressure:

150 % of span (0.5 MPa: 2000 % of span, 1 MPa: 1000 % of span)

Fixing screw section material:

SUS630

Lead pipe cover material:

SUS304 (Fixed nut type only)

Diaphragm material:

SUS630, HASTELLO Y C, SPRON, INCONEL

Recommended tightening torque:

Fixed nut type: 30 N·m (300 kgf·cm)

Loose nut type: 60 N·m (600 kgf·cm)



For the HASTELLO Y C diaphragm type specification, contact our sales office or your nearest RKC sales agent.

■ Temperature measurement section (Optional)**Temperature sensor type:** Thermocouple: K or J (Ungrounded junction)**Maximum operating temperature:** K type: 550 °C

J type: 450 °C

Temperature detection position: Internally 2 mm from a diaphragm**Response time:** Approx. 90 seconds
(room temperature → 100 °C, 98 % response)**Connector:** Mini-connector

(Continuous operating temperature 120 °C)

Flexible tube: Material: SUS304 (External diameter $\phi 5.6$)

Bending radius: 19 mm or more

9. EXPLANATION OF EACH TERMS

Term	Explanation
Rated pressure	The maximum pressure which satisfies the specification. There are stipulated pressure ranges.
Rated output	Value obtained by subtracting the output at no-load from that at the rated pressure load. Electrically, it is output voltage per Volt in DC (mV/V) obtained through the bridge circuit when rated pressure is applied. At an application voltage of 10 V from the converter, a voltage of $mV \times 10$ is output.
Accuracy	The maximum error including linearity and hysteresis.
Linearity	The maximum error from a reference line (straight line without error) when pressure-loaded in the pressure rise direction continuously from no-load to the rated pressure.
Hysteresis	The maximum difference between pressures at the same point in the rise and fall directions when the same pressure is loaded.
Repeatability	The difference between measured values obtained each time when pressure-loaded three times repeatedly from no-load to the rated pressure within a short period of time*.
Temperature effect on zero point	Zero-point output variation when the diaphragm temperature changes by 10 °C.
Temperature effect on output (sensitivity)	Output sensitivity (span) variation when the diaphragm temperature changes by 10 °C.
Allowable overpressure	The high limit of overpressure within a short period of time* at which the accuracy can be guaranteed even after the pressure returns to the rated pressure when overpressure-loaded.
Limit overpressure	The high limit of overpressure within a short period of time* at which no diaphragm is damaged when overpressure-loaded. However, no accuracy is guaranteed after the pressure returns to the rated pressure.

* Short period of time: From several seconds to several minutes.

SPRON® is a registered trademark of Seiko Instruments Inc.

INCONEL® is a registered trademark of Special Metals Corporation.

Company names and product names used in this manual are the trademarks or registered trademarks of the respective companies.

The first edition: MAR. 1998

The eleventh edition: JUL. 2023 [IMQ01]

RKC® RKC INSTRUMENT INC.

HEADQUARTERS: 16-6, KUGAHARA 5-CHOME, OHTA-KU TOKYO 146-8515 JAPAN

PHONE: 03-3751-9799 (+81 3 3751 9799)

E-mail: info@rkcinst.co.jp

Website: <https://www.rkcinst.co.jp/english/>

IM100CZ08-E11

JUL. 2023